

Pictures of Jesus

Lesson Objectives

- The students will use their Bibles to describe Jesus.
- The students will state that Jesus is worthy to be worshiped.
- The students will participate in a student worship service.

Lesson Text

Revelation 5:1-14

Scripture Memory Verse

In a loud voice they sang:
 "Worthy is the Lamb, who
 was slain,
 to receive power and wealth
 and wisdom and strength
 and honor and glory and praise!"
Revelation 5:12

Lesson Plan

Greeting and Registration

Preclass Activity: Words of Worship

Welcome and Singing

Centers:

Bible Story: Picture This!

Craft: Singing in the Reign

Scripture Memory: Loud Voices

NOTE: Allow time for a snack.

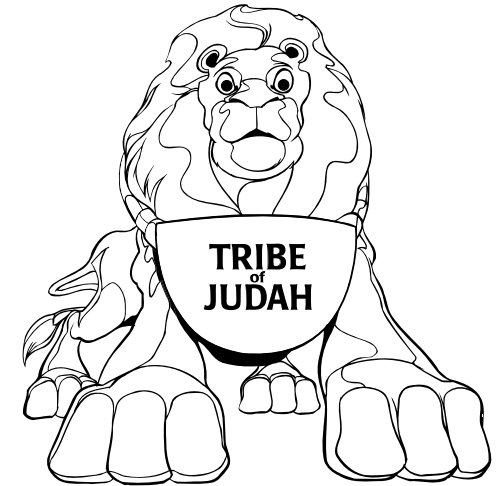

P
R
E
•
C
L
A
S
S

Pictures of Jesus

Words of Worship

The students will preview today's lesson as they search for key words from today's Bible Story.

Materials

For each student:

- pencil

Reproducible Pages:

- Page A, 1 copy for each student

Preparation

Complete the activity on your copy of Reproducible Page A.

Instructions

1. Greet the students as they arrive. Tell them that today they will continue to study the book of Revelation and look at ways to worship Jesus. Show the students your copy of Reproducible Page A. Explain that in today's activity, they will search for words that come from Revelation 5 that describe Jesus and worship.
2. Distribute the copies of Reproducible Page A and pencils. Encourage the students to work together and help each other.
3. Circulate among the students to offer help and encouragement.
4. Check the students' answers with your Answer Key.

Teachers Tips

- Play background music with a worshipful theme during this activity.

Words of Worship

Instructions: Find and circle the words listed below.

W	O	R	T	H	Y	Q	W	R	L	T	Y
I	U	I	O	O	P	A	S	L	A	I	N
S	S	D	F	N	G	H	T	J	M	K	L
D	Z	X	C	O	V	B	R	N	B	M	Q
O	W	T	H	R	O	N	E	E	R	T	P
M	Y	U	E	I	O	P	N	A	S	D	O
F	G	H	A	J	K	L	G	Z	X	C	W
V	B	N	V	M	P	Q	T	W	E	R	E
T	Y	U	E	A	R	T	H	I	O	P	R
A	S	D	N	F	A	G	H	J	K	L	Z
X	C	V	B	N	I	M	Q	W	E	R	T
Y	U	I	O	P	S	A	S	D	F	G	H
J	K	L	Z	W	E	A	L	T	H	X	C

WORTHY

HEAVEN

EARTH

LAMB

SLAIN

POWER

STRENGTH

WISDOM

WEALTH

HONOR

PRAISE

THRONE

Open your Bible to Revelation 5. See how many of these words you can find. Write the reference(s) where they appear in the spaces provided.

WORTHY _____ Revelation 5:2, 4, 9, 12

LAMB _____ Revelation 5:6, 8, 12, 13

STRENGTH _____ Revelation 5:12

HONOR _____ Revelation 5:12, 13

HEAVEN _____ Revelation 5:3, 13

SLAIN _____ Revelation 5:6, 9, 12

WISDOM _____ Revelation 5:12

PRAISE _____ Revelation 5:12, 13

EARTH _____ Revelation 5:3, 6, 10, 13

POWER _____ Revelation 5:12, 13

WEALTH _____ Revelation 5:12

THRONE _____ Revelation 5:1, 6, 7, 11, 13

Pictures of Jesus

Picture This!

The students will hear and visualize descriptions of Jesus from Revelation 5.

Materials

For each student:

- pencil
- crayons

For the teacher:

- large writing surface

Reproducible Pages:

- Page B, 1 copy for each student

Preparation

Practice presenting this Bible Story with energy and enthusiasm.

Introducing the Bible Story

Open your Bible to Revelation 5. Tell the students that today's Bible Story is a continuation of their study in the New Testament book of Revelation. Tell the students that in today's lesson, they will hear and imagine some descriptions of Jesus from Revelation 5.

On the large writing surface, neatly print: Lion, Root, Lamb. Ask the students what they think that these three words have in common. Take responses. Explain that they are each used to describe Jesus.

- *Have you ever seen a real lion? Where? How close did you get? How did it make you feel? What words would you use to describe a lion?* (Write their answers on the large writing surface.)
- *Have you ever seen a tree root? Why is a root important to a plant?* (It contains the source for all nutrients; it is the life source of the plant. Write their answers on the large writing surface.)
- *Have you ever seen a real lamb? Where? How close did you get? How did it make you feel? What words would you use to describe a lamb?* (Write their answers on the large writing surface.)

In Revelation 5, the apostle John uses all of these images to help us understand how powerful and magnificent Jesus is. John's visions of Jesus not only help us to see that Jesus is worthy of our praise and worship, but also how Jesus is worshiped in heaven.

Presenting the Bible Story

Distribute the copies of Reproducible Page B, pencils and crayons. Tell the students that they will use the pictures on their pages to help them imagine some of the descriptions of Jesus in Revelation 5. Let them color their pictures and then open to Revelation 5 and follow along carefully. You will read different passages as they try to find the picture that best matches the description you are reading.

Then I saw in the right hand of him who sat on the throne a scroll with writing on both sides and sealed with seven seals (Revelation 5:1).

Ask the students to find the picture that best fits this verse and write, "Revelation 5:1," underneath.

And I saw a mighty angel proclaiming in a loud voice, "Who is worthy to break the seals and open the scroll?" But no one in heaven or on earth or under the earth could open the scroll or even look inside it. I wept and wept because no one was found who was worthy to open the scroll or look inside (Revelation 5:2-4).

Ask the students to find the picture that best fits this verse and write, "Revelation 5:2-4," underneath.

Then one of the elders said to me, "Do not weep! See, the Lion of the tribe of Judah, the Root of David, has triumphed. He is able to open the scroll and its seven seals" (Revelation 5:5).

Ask the students to find the picture that best fits this verse and write, "Revelation 5:5," underneath.

Then I saw a Lamb, looking as if it had been slain, standing in the center of the throne, encircled by the four living creatures and the elders. He had seven horns and seven eyes, which are the seven spirits of God sent out into all the earth. He came and took the scroll from the right hand of him who sat on the throne (Revelation 5:6-7).

Ask the students to find the picture that best fits this verse and write, "Revelation 5:6-7," underneath.



3rd and 4th Grades

Pictures of Jesus

And when he had taken it, the four living creatures and the twenty-four elders fell down before the Lamb. Each one had a harp and they were holding golden bowls full of incense, which are the prayers of the saints. And they sang a new song:

*"You are worthy to take the scroll
and to open its seals,
because you were slain,
and with your blood you purchased men for God
from every tribe and language and people and nation.
You have made them to be a kingdom and priests to
serve our God,
and they will reign on the earth" (Revelation 5:8-10).*

Ask the students to find the picture that best fits this verse and write, "Revelation 5:8-10," underneath.

Then I looked and heard the voice of many angels, numbering thousands upon thousands, and ten thousand times ten thousand. They encircled the throne and the living creatures and the elders. In a loud voice they sang:

*"Worthy is the Lamb, who was slain,
to receive power and wealth and wisdom and strength
and honor and glory and praise!" (Revelation 5:11-12)*

Ask the students to find the picture that best fits this verse and write, "Revelation 5:11-12," underneath.

Then I heard every creature in heaven and on earth and under the earth and on the sea, and all that is in them, singing:

*"To him who sits on the throne and to the Lamb
be praise and honor and glory and power,
for ever and ever!"*

The four living creatures said, "Amen," and the elders fell down and worshiped (Revelation 5:13-14).

Ask the students to find the picture that best fits this verse and write, "Revelation 5:13-14," underneath.

Sharing with Others

Ask the students to use today's Bible Story to describe Jesus. Encourage the students to share what they have learned about Jesus with a friend or family member this week. Close with a prayer based on Revelation 5, praising God for Jesus.

Teacher Tips

- Read the scriptures with feeling and emphasize the aspects that describe Jesus' power and majesty.
- Encourage the students not to become sidetracked with the peculiar or unfamiliar images described in some of these verses, but rather to see the bigger picture of Jesus' power and majesty.
- Give the students time at the end to finish coloring their pictures, if necessary.

C

R

A

F

T

Pictures of Jesus

Singing in the Reign

The students will make a craft to remind them of today's Bible Story.

Materials

For each student:

- 1 cardboard tube, approximately 4"
- 1 piece of construction paper, 4½" x 6"
- glue stick
- invisible tape
- poster board, 4" x 5"
- scissors
- crayons or markers

For the teacher:

- scissors
- ruler

Reproducible Pages:

- Page C, 1 copy for each student

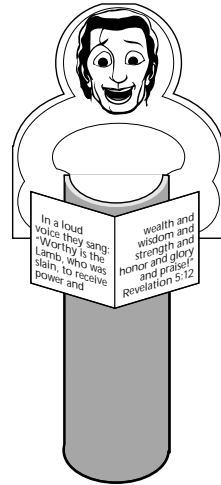

Preparation

1. Cut a 4" x 5" piece of poster board for each student.
2. Cut a 4½" x 6" piece of colored construction paper for each student.
3. Make a sample of the craft to show the students.

Instructions

1. Introduce today's activity: *In today's Bible Story, you are learning more about the book of Revelation. In Revelation 5, the apostle John describes his vision of Jesus in an awesome and powerful way. Jesus is described as the "Lion of the tribe of Judah" and "the Root of David." Then, Jesus is described as the Lamb who was slain. (Explain that "slain" means killed or murdered, which was what happened to Jesus on the cross.) John says that he saw and heard "thousands upon thousands, and ten thousands times ten thousand" angels surrounding the throne where Jesus was. John says that these angels were singing praises to Jesus in loud voices. In your activity today, you will make a craft to remind you of the multitude of angels that were singing and worshiping Jesus. Show the students your sample of the angel. Read the words on the songbook to them.*

2. Distribute the pieces of colored construction paper, cardboard tubes, glue sticks and tape. Have the students glue their construction paper to their tubes. Have them reinforce the seam with tape where the paper overlaps. See Figure A.
3. Distribute the copies of Reproducible Page C, and the scissors. Have the students each cut out their angels and songbooks. NOTE: Instruct the students to cut only the box around the angel at this time.
4. Distribute the pieces of the poster board and the crayons. Have them glue their angels to the poster board. Have them color their angels.
5. While the students are coloring, circulate around the room and cut two 1" slits into one end of their covered tubes, as shown in Figure B.
6. Have the students cut out their angels along the thick, outer lines. See Figure C.
7. Have the students insert their angels into the slits of their tubes. See Figure D.
8. Have the students glue their songbooks to the front of their tubes, as shown in Figure E.

Conclusion

Ask the students to each say one reason why Jesus is worthy to be worshiped. Close with a prayer praising God for Jesus.

Teacher Tips

- If you precut the slits on the cardboard tubes, then you only have to cut the construction paper portion of the slits during class.
- Toilet paper tubes are the perfect size for this craft.

Pictures of Jesus

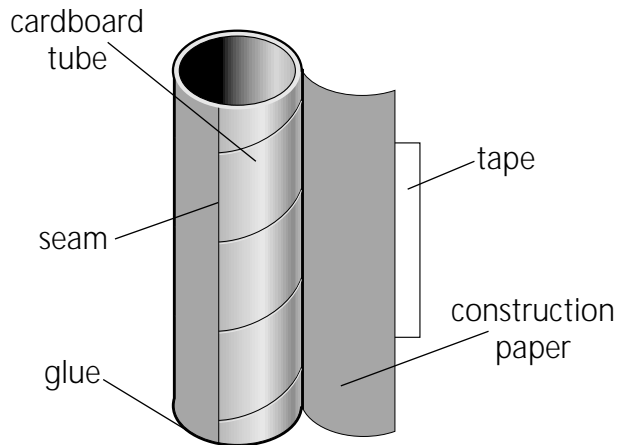

Figure A

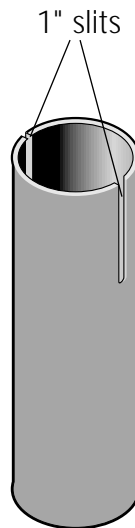

Figure B

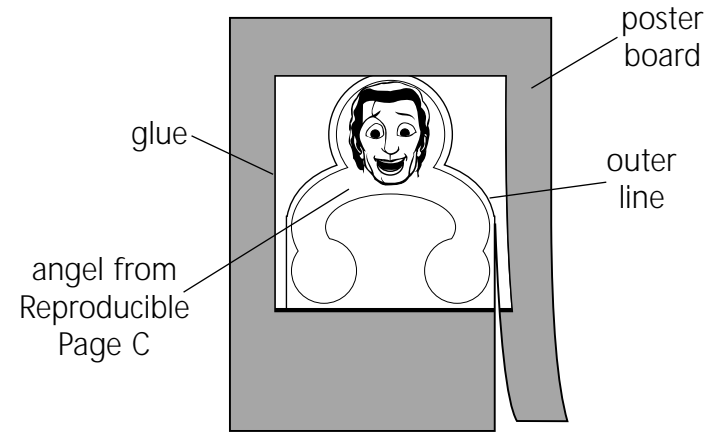

Figure C

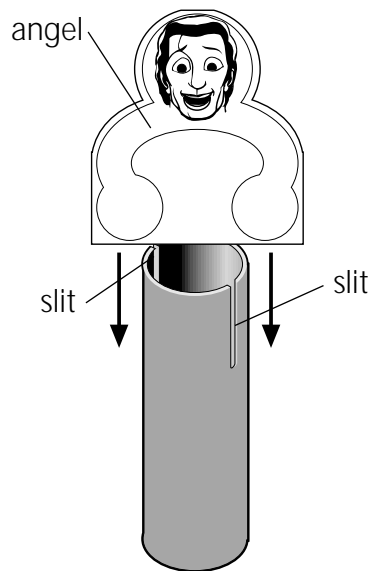

Figure D

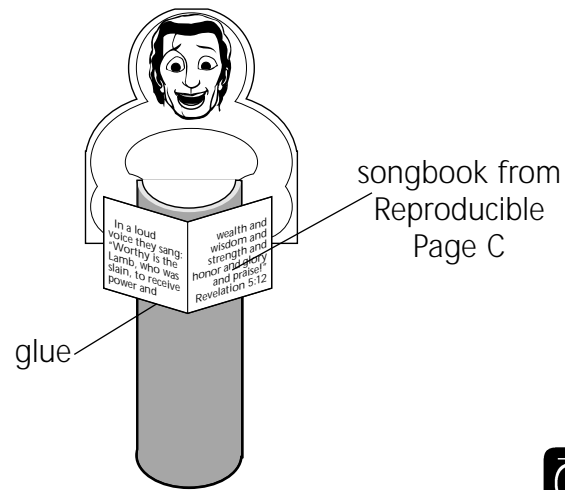

Figure E

Pictures of Jesus

Loud Voices

The students will learn and memorize today's Scripture Memory Verse through a choral activity.

Scripture Memory Verse

In a loud voice they sang:

"Worthy is the Lamb, who was slain,
to receive power and wealth and wisdom and strength
and honor and glory and praise!"

Revelation 5:12

Materials

For each student:

- 1 piece of silver or gold garland, 24" (optional)

For the teacher:

- scissors
- large writing surface
- tape

Reproducible Pages:

- Page D, 1 copy for each student

Preparation

1. Cut out the song sheets from the copies of Reproducible Page D and fold in half along the dashed line.
2. Make headpieces for the students by forming circles from the garlands and taping them together.
3. Neatly print on the large writing surface these words: whisper, softly, normal, loud, louder, very loud.
4. Practice singing or chanting this verse so that you are comfortable leading the students through this activity.

Instructions

1. Introduce today's activity: *In today's Bible Story, you are learning more about the book of Revelation. In Revelation 5, the apostle John describes his awesome vision of Jesus as the "Lion of the tribe of Judah" and "the Root of David." Then Jesus is described as the Lamb who was slain.* (Explain that "slain" means killed or murdered, which was what happened to Jesus on the cross.) *John says that he saw and heard "thousands upon thousands, and ten thousands times ten thousand" angels surrounding the*

throne and singing in loud voices to Jesus. In your Scripture Memory Verse, you will learn the words to the song they sang.

2. Show the students the Scripture Memory Verse on the back of this Lesson Card. Say it three times to them as they listen. Ask them to say it together with you three more times—each time varying the speed.
3. Tell the students that these are the words that thousands and thousands of angels sang in loud voices to praise Jesus. Explain that they will each pretend to be an angel singing in chorus together while you lead them.
4. Distribute the headpieces (if available) and the song sheets that you prepared. Have the students form a semi-circle around you. Explain that they will represent angels from Revelation 5 and sing this verse in different voices.
5. Show the students the list on the large writing surface. Explain that they will sing or chant the Scripture Memory Verse in each of the ways listed. Tell them that you will lead them in saying the verse two times each way described, then they will do the same.
6. After the students have finished, ask for volunteers to say, sing or chant the verse alone or with a partner. Have the remaining students hum softly in the background as the soloists sing. Repeat this for all the students who volunteer.

Conclusion

Ask the students how they think it would have felt to see and hear all those angels singing around Jesus. Close with a prayer praising God for Jesus.

Teacher Tips

- During class, play a recording of the verse as sung in the 3rd movement of Handel's Messiah. If you do not have a recording, borrow one from your local library or a friend.
- Depending on your class location, you might need to remove "very loud" from the list.

In a loud voice they sang:

“Worthy is the Lamb, who was slain,
to receive power and wealth and
wisdom and strength
and honor and glory and praise!”

Revelation 5:12

Lesson Objectives

- The students will use their Bibles to describe Jesus.
- The students will state that Jesus is worthy to be worshiped.
- The students will participate in a student worship service.

Lesson Text

Revelation 5:1-14

Scripture Memory Verse

In a loud voice they sang:

“Worthy is the Lamb, who was slain,
to receive power and wealth and wisdom and strength
and honor and glory and praise!”

Revelation 5:12

Lesson Plan

Greeting and Registration

Preclass Activity: Service with a Smile

Welcome and Singing

Centers:

Life Application: He Is Worthy

Game: Good News!

Bible Skills: Preach the Word

SPECIAL TEACHER NOTE: Each center will be only ten minutes long. The class will conclude with a twenty-minute Student Worship Service followed by fellowship and snacks. Please see the “Important Note to the Lead Teacher” on the Life Application card.

D
R
E
•
C
•
A
S
S

Service with a Smile

The students will review this week’s Bible Story as they prepare a Student Worship Guide to use in class.

Materials

For each student:

- 1 piece of construction paper, 9" x 12"
- scissors
- glue stick
- pencil

Reproducible Pages:

- Page E, 1 copy for each student
- Page F, 1 copy for each student

Preparation

1. Make a sample Student Worship Guide to show the students.
2. Fold each piece of construction paper in half making 9" x 6" booklets for the students.

Instructions

1. Greet the students as they arrive. Remind them that they are learning about the book of Revelation and ways to worship Jesus. Tell the students that they will have a student worship service today. Show them your sample booklet and tell the students that they will use these to help plan their service.
2. Distribute the copies of Reproducible Pages E and F, scissors, glue sticks and prepared booklets. Tell the students to cut out each page from their copies of Reproducible Pages E and F and glue them in order on each of the four sides of their booklets.
3. Have the students write their names on their booklets and take them to each center today.

4. Give your sample booklet to the Life Application teacher.

Teacher Tips

- Do not have the students fill in the blank spaces on their booklet pages at this time.

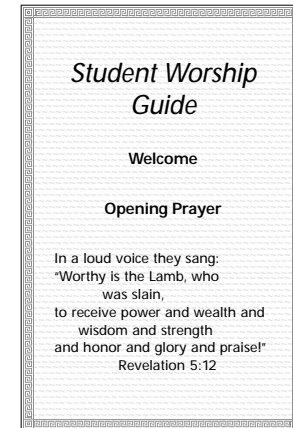

3rd and 4th Grades

He Is Worthy

The students will review this week's Bible Story as they prepare the singing portion of their student worship service.

Materials

For each student:

- Student Worship Guide from Preclass Activity
- *Songs of the Kingdom*, second edition
- pencil

For the teacher:

- sample Student Worship Guide from Preclass Activity
- *Songs of the Kingdom*, second edition
- large writing surface

Important Note to the Lead Teacher

Each center will be shortened to last only ten minutes. After the students have completed all three centers, conduct a twenty-minute student worship service, using the Student Worship Guide prepared during the Preclass Activity. Follow with a time of food (snacks) and fellowship. Assign each adult to assist the students in the different aspects of the service. Make arrangements in advance with your Children's Ministry Leaders to have a location, complete with chairs and a podium, to hold your student worship service.

You and/or your assistant teachers will be responsible for the welcome and prayer during portions of the service. Make sure to collect the names of all the students who volunteer from your teachers before you begin the service.

Preparation

1. Neatly print these song titles on the large writing surface:
I'm Gonna View That Holy City, 909
In My Father's House, 911
Rejoice in the Lord Always, 918
2. Practice leading these songs. The number refers to where the song is located in *Songs of the Kingdom*.
3. Be prepared to complete this activity in ten minutes.
NOTE: If you do not have this songbook, locate these songs in another songbook or choose three different songs with a theme of heaven and praising Jesus.

Reviewing the Bible Story

Open your Bible to Revelation 5. *This week you listened to verses from Revelation 5 in which Jesus was described as the Lion of the tribe of Judah, the Root of David, and a Lamb that had been slain. In that passage, Jesus was surrounded by thousands and thousands of angels who were singing his praises. This amazing description of worship is an example for us today. In each of your center activities, you will prepare to praise and worship Jesus in a student worship service during the second half of today's class.*

Life Application

Distribute the songbooks to the students. Practice singing all three songs with the students. Ask for one student volunteer to lead one of the songs for the worship service. Write the student's name beside the song he will be leading on the large writing surface, and have the students write it in the appropriate space on page 2 or page 4 of their Student Worship Guides.

NOTE: If the students are divided into three small groups, then each center should provide one student song leader to lead one song. If all the students are together, then choose three different volunteers to lead the three songs.

Conclusion

Encourage the students to think about the angels in heaven singing around Jesus as they sing during their worship service.

Teacher Tips

- If you are not familiar with song leading, ask someone who has led singing to help you.
- If possible, invite a disciple or a student who plays guitar or another instrument to come and perform a song of worship for this service. Make sure they have enough time to practice during the week. Arrange to listen to them in advance and offer helpful suggestions and encouragement.
- Invite a disciple to videotape the service. Arrange to show it to the students during your next class or invite the students to your home for a special viewing.



3rd and 4th Grades



Good News!

The students will continue to think about ways to worship Jesus as they prepare the good news portion of today's student worship service.

Materials

For each student:

- Student Worship Guides from Preclass Activity
- pencil

For the teacher:

- paper and pen



Important Note to the Teacher

Each center will be shortened to last ten minutes. Talk with your Lead Teacher about the schedule for today's class. You will be preparing the students to participate in the good news sharing portion of today's student worship service.

Preparation

1. Think of examples of good news sharing: concise, focused statements of ways that God has moved in your life or ministry.
2. Be prepared to complete this activity in just ten minutes.



Instructions for the Good News Sharing

This week in your Bible Story in Revelation, you learned that Jesus was worshiped by thousands and thousands of angels who were powerfully singing his praises. The book of Revelation gives us some amazing descriptions of Jesus' power and glory. In this lesson, you learned that Jesus is worthy of our worship and our praise. In our activity today, we will prepare the "good news" portion of our own Student Worship Service during the second half of class.

Ask the students if they can think of some good news, e.g. ways that God has helped them or their family recently; a friend who has, or wants to, come to church; a sinful behavior that has really changed; something that they have received honor or praise for doing excellently, etc. Neatly print the students' answers on a piece of paper. Ask for a volunteer from your group to present this good news during the student worship service. Make sure that this student is not already leading a prayer or a song. Give the volunteer the paper containing the good news. Have the students write the volun-



teer's name in one of the spaces provided on page 3 of their Student Worship Guides.

NOTE: If the students have been divided into three small groups, then each center should provide one student to share good news—for a total of three. If all the students are together for this activity, then choose three different volunteers to give Good News.

Conclusion

Encourage the students to express their support of the student volunteer(s) from their group who will be sharing by saying, "Amen," or clapping during the worship service.

Teacher Tips

- Give the names of your student volunteer(s) to the Lead Teacher before the student worship begins.

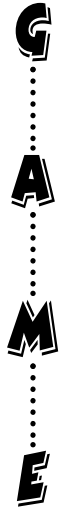

Preaching the Word

Revelation 5:9 by

_____ (student #1)

Revelation 5:10 by

_____ (student #2)

Revelation 5:12 by

_____ (student #3)

Good News Sharing

_____ (student #1)

_____ (student #2)

_____ (student #3)

B I B L E S K I L L S

Preach the Word

The students will continue to think about ways to worship Jesus as they prepare to preach the word from Revelation in today's student worship service.

Materials

For each student:

- Student Worship Guides from Preclass Activity
- pencil

For the teacher:

- paper and pen
- large writing surface

Important Note to the Teacher

This center will be shortened to last ten minutes. Talk with your Lead Teacher about the schedule for today's class. You will be preparing the students to preach scriptures from Revelation during today's student worship service.

Preparation

1. Neatly print the following scripture references on the large writing surface:
Revelation 5:9
Revelation 5:10
Revelation 5:12
2. Practice preaching each of these verses.
3. Be prepared to complete this activity in just ten minutes.

Instructions for Preaching the Word

This week in your Bible Story in Revelation, you learned that Jesus was worshiped by thousands and thousands of angels who were powerfully singing his praises. The book of Revelation gives us some amazing descriptions of Jesus' power and glory. In this lesson, you learned that Jesus is worthy of our worship and our praise. In our activity today, we will prepare the "preaching the word" portion of our own worship service that will be held during the second half of class.

Have the students open their Bibles to Revelation 5. Read the three verses from the back of this Lesson Card to the students.

Tell them that you will read them again, but this time you are going to "preach" them. Preach all three verses to the students. Then have them imitate you.

Ask for a volunteer from your group to preach one of these three verses during the Student Worship Service. Make sure that this student is not already leading a prayer, song or good news sharing. Assign one of these verses to the student and have the students write the volunteer's name in one of the spaces provided on page 3 of their Student Worship Guides.

NOTE: If the students have been divided into three small groups, then each center should provide one student to preach a verse—for a total of three. If all the students are together, then choose three different volunteers to preach the three scriptures.

Conclusion

Encourage the other students to express their support of the student volunteer(s) from their group who will be preaching by saying, "Amen," or clapping during the worship service.

Teacher Tips

- Give the names of your student volunteer(s) to the Lead Teacher before the student worship begins.

Revelation 5:9

And they sang a new song:

“You are worthy to take the scroll
and to open its seals,
because you were slain,
and with your blood you purchased men for God
from every tribe and language and people and nation.”

Revelation 5:10

“You have made them to be a kingdom and priests to serve our God,
and they will reign on the earth.”

Revelation 5:12

In a loud voice they sang:

“Worthy is the Lamb, who was slain,
to receive power and wealth and wisdom and strength
and honor and glory and praise!”

Name _____

Words of Worship

Instructions: Find and circle the words listed below.

W	O	R	T	H	Y	Q	W	R	L	T	Y
I	U	I	O	O	P	A	S	L	A	I	N
S	S	D	F	N	G	H	T	J	M	K	L
D	Z	X	C	O	V	B	R	N	B	M	Q
O	W	T	H	R	O	N	E	E	R	T	P
M	Y	U	E	I	O	P	N	A	S	D	O
F	G	H	A	J	K	L	G	Z	X	C	W
V	B	N	V	M	P	Q	T	W	E	R	E
T	Y	U	E	A	R	T	H	I	O	P	R
A	S	D	N	F	A	G	H	J	K	L	Z
X	C	V	B	N	I	M	Q	W	E	R	T
Y	U	I	O	P	S	A	S	D	F	G	H
J	K	L	Z	W	E	A	L	T	H	X	C

- | | | | |
|--------|-------|----------|--------|
| WORTHY | LAMB | STRENGTH | HONOR |
| HEAVEN | SLAIN | WISDOM | PRAISE |
| EARTH | POWER | WEALTH | THRONE |

Open your Bible to Revelation 5. See how many of these words you can find. Write the reference(s) where they appear in the spaces provided.

- WORTHY Revelation 5:2, 4, 9, 12
- LAMB _____
- STRENGTH _____
- HONOR _____
- HEAVEN _____
- SLAIN _____
- WISDOM _____
- PRAISE _____
- EARTH _____
- POWER _____
- WEALTH _____
- THRONE _____



Core/Bible Story
1 copy for each student

Name _____

Picture This!



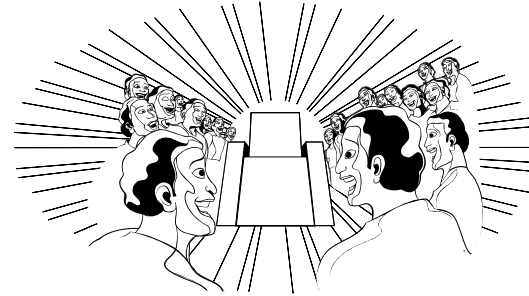

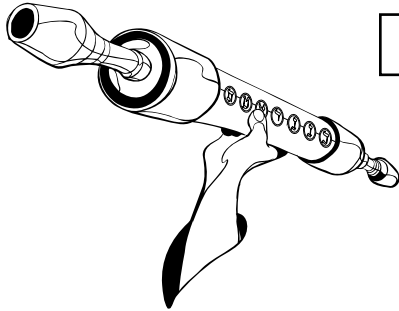

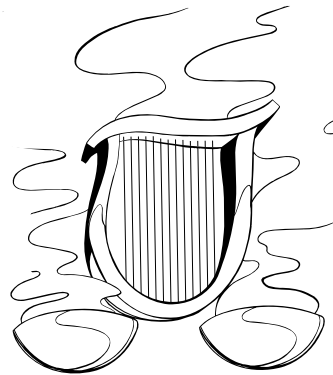

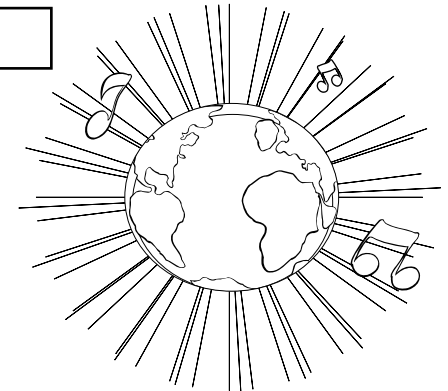

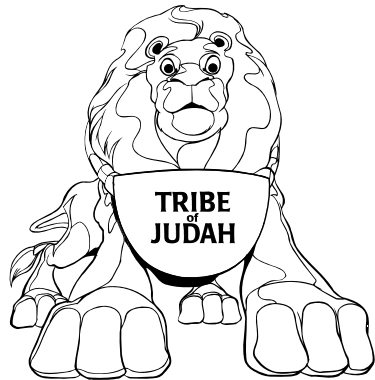

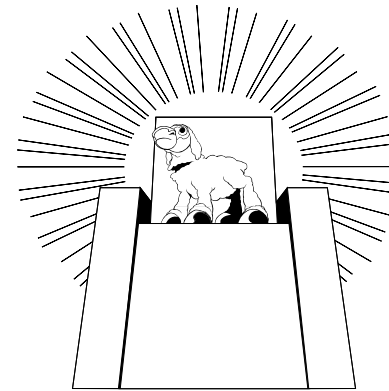

Core/Craft

1 copy for each student

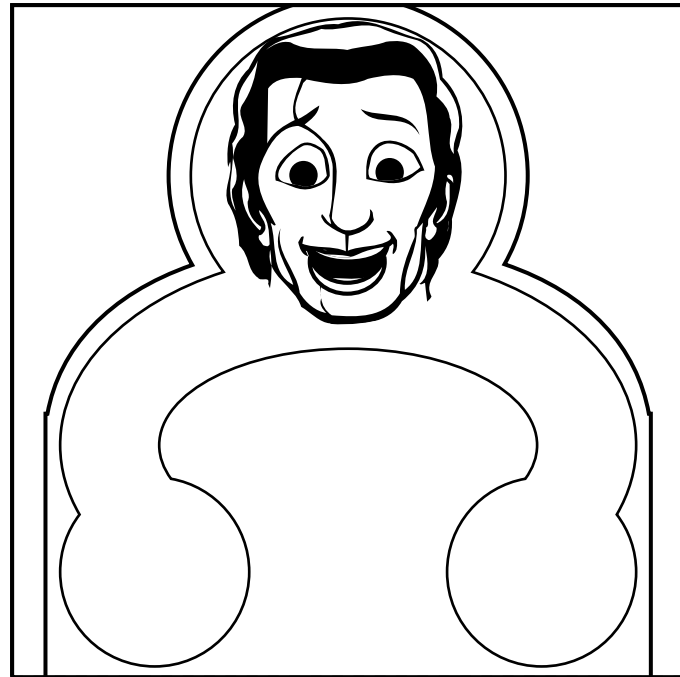

singing angel

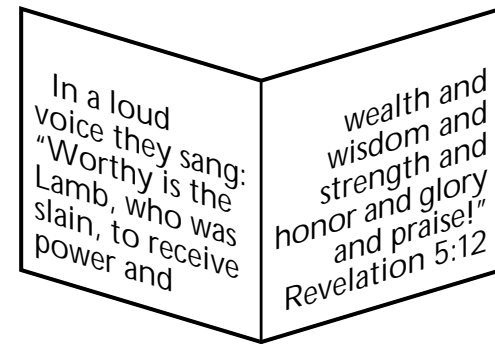

songbook

Core/Scripture Memory

1 copy for each student

In a loud voice	they sang:
“Worthy is the Lamb	who was slain,
to receive power and wealth	and wisdom and strength
and honor and glory	and praise!”
Revelation	5:12

Student Worship Guide

Welcome

Opening Prayer

In a loud voice they sang:
"Worthy is the Lamb, who
was slain,
to receive power and wealth and
wisdom and strength
and honor and glory and praise!"
Revelation 5:12

Opening Song #1

_____ (title)

led by

_____ (student #1)

Song #2 before the Sermon

_____ (title)

led by

_____ (student #2)

Page 2

Cut out and glue to the front cover.

Cut out and glue to the inside left page.
(The blank spaces will be completed during class.)

Supplement/Preclass

1 copy for each student

Preaching the Word

Revelation 5:9 by

_____ (student #1)

Revelation 5:10 by

_____ (student #2)

Revelation 5:12 by

_____ (student #3)

Good News Sharing

_____ (student #1)

_____ (student #2)

_____ (student #3)

Page 3

Closing Prayer

Closing Song #3

_____ (title)

led by

_____ (student #2)

Food and Fellowship!

Page 4

Cut out and glue to the inside right page.
(The blank spaces will be completed during class.)

Cut out and glue to the back cover.
(The blank spaces will be completed during class.)