

Hidden Treasure

Lesson Objectives

- The children will participate in the parable of the hidden treasure.
- The children will state that God's kingdom is a treasure.
- The children will state one thing of theirs that God's kingdom is more valuable than.

Lesson Text

Matthew 13:44

Scripture Memory Verse

"The kingdom of heaven is like treasure hidden in a field."

Matthew 13:44

Lesson Plan

Greeting and Registration

Preclass Activity: Kingdom Jewels

Welcome and Singing

Centers:

Bible Story: Field of Dreams

Craft: Kingdom Treasures

Scripture Memory: Treasure Hidden

NOTE: Allow time for a snack.

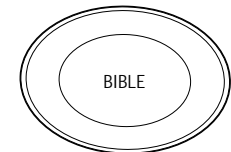
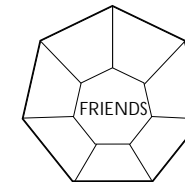
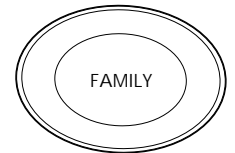
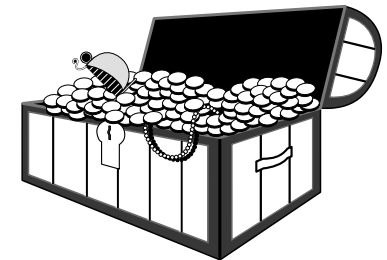
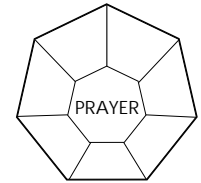
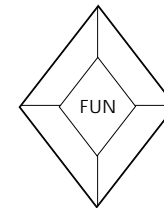

Hidden Treasure

Kingdom Jewels

The children will make "Kingdom Jewels" to be used later in their craft.

Materials

For each child:

- scissors
- crayons
- glue stick
- decorative items: glitter, sequins, etc.
- envelope

Reproducible Pages:

- Page A, 1 copy for each child

Preparation

Make a sample of the finished jewels to show the children.

Instructions

1. Greet the children as they arrive. Explain to them that in today's Bible Story they will learn that the kingdom of God is like a hidden treasure. Show the children your sample of the jewels.
Today you will make jewels to put into a treasure chest that you will make during the Craft center. Read what is written on the jewels. These are the treasures we find in the kingdom!
2. Distribute the copies of Reproducible Page A, crayons and scissors. Have the children color their jewels and then cut them out.
3. Distribute the glue sticks and decorative items. Have the children choose any of the decorative items and glue these onto their jewels.
4. Distribute the envelopes and have the children write their names on them. Have them place their finished jewels inside their envelopes.
5. Collect the envelopes and give them to the Craft teacher.

Teacher Tips

- Have the children who finish early cut out and decorate some jewels for any children who may arrive late.

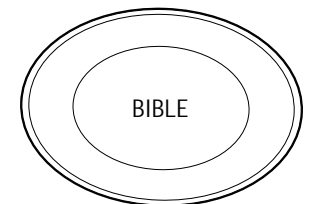
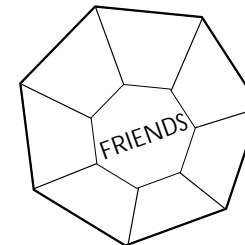
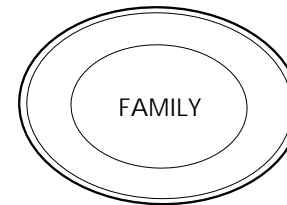
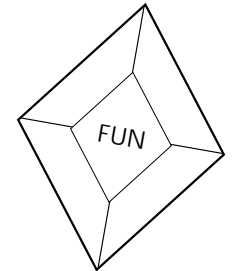
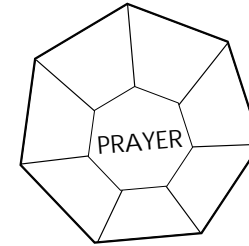

B

Hidden Treasure

Parables
Lesson 3

S

Field of Dreams

The children will participate in the parable of the hidden treasure.

Materials

For the teacher:

- 1 piece of cardboard or poster board, 9" x 12"
- marker
- 1 medium box (shirt size or larger)
- shredded paper or Styrofoam "popcorn"
- scissors
- glue stick

Reproducible Pages:

- Page B, 1 copy for the teacher (on yellow or gold paper)

Preparation

1. Glue your copy of Reproducible Page B to the cardboard and let dry. Cut out the coins.
2. Place the shredded paper in the box.
3. Hide the coins in the box.

Introduction to the Bible Story

Open your Bible to Matthew 13. Tell the children that today's Bible Story comes from the New Testament book of Matthew. Explain that today they will hear another parable of Jesus.

- *Who remembers what a parable is?* (a story that teaches about God)
- *Who remembers some of Jesus' parables that we have already learned?* (mustard seed; yeast)
- *Who remembers what Jesus taught us in these parables?* (kingdom of heaven is like a mustard seed that starts small but grows very large; the kingdom of heaven is like yeast—a little bit can make a big difference)

Today you will learn a new parable from Matthew 13:44. In this parable, Jesus said that the kingdom of heaven is like a hidden treasure. A treasure is something very, very valuable. Share an example of something that you treasure, such as an heirloom, photograph or special piece of jewelry. Can you think of something that is very, very special or valuable to you? (Take responses.) These things are your "treasures."

Presenting the Bible Story

Help the children to open their Bibles to Matthew 13:44. Tell the children to follow along as you read Matthew 13:44.

"The kingdom of heaven is like treasure hidden in a field. When a man found it, he hid it again, and then in his joy went and sold all he had and bought that field."

Read it again three more times. Invite the children to read it along with you. Ask the children to stand up. Tell them that you are going to read the parable and they are going to act it out. Read the parable slowly and have the children act out the words "found it," "hid it again," "in his joy," "sold all he had" and "bought that field." Offer an example for each of these to show the children.

Jesus says that God's kingdom is like a treasure. What are some very, very special things about God's kingdom that make it a treasure? (Take responses. Offer ideas such as: best friends, the Bible, people who can help us when we have problems, prayer, etc.) Make sure to add that the most special treasure is that disciples of Jesus will go to heaven and be with God forever.

Kingdom Treasures

In this parable, Jesus said that the kingdom of heaven is like a hidden treasure. That means we have to look for it. Take out the box you prepared. Explain that inside this box are a number of treasures—some are "kingdom" treasures and some are not. Tell the children that they will each take a turn looking for one of the treasures in the box. When they are all chosen, they will decide which are kingdom treasures. Choose a child to reach in to find one of the coins. Do this until all of the coins have been found.

Help the children to read their coins. Ask the children to say which of the coins display kingdom treasures and which do not. (Kingdom Treasures are denoted with a crown on each coin.) Ask the children which of these treasures they would choose as the most valuable and why.

NOTE: Do not show disapproval of their choices. This may be a revealing activity to help you know what is important to the children. Offer ideas such as: *New clothes and a lot of money are great, but only if we have real friends who like us for who we are. God wants*



B
S
I
T
B
O
L
R
E
Y

Hidden Treasure

us to have the things we need and want—as long as they do not hurt God, ourselves or others.

Share and Tell

Encourage the children for their participation. Ask them to share what they learned today with a friend or someone in their family. Close with a prayer thanking God for the treasures he gives us in his kingdom.

Teacher Tips

- Think of ways to embellish the box or bring in a “treasure chest” if you can get one for this activity.

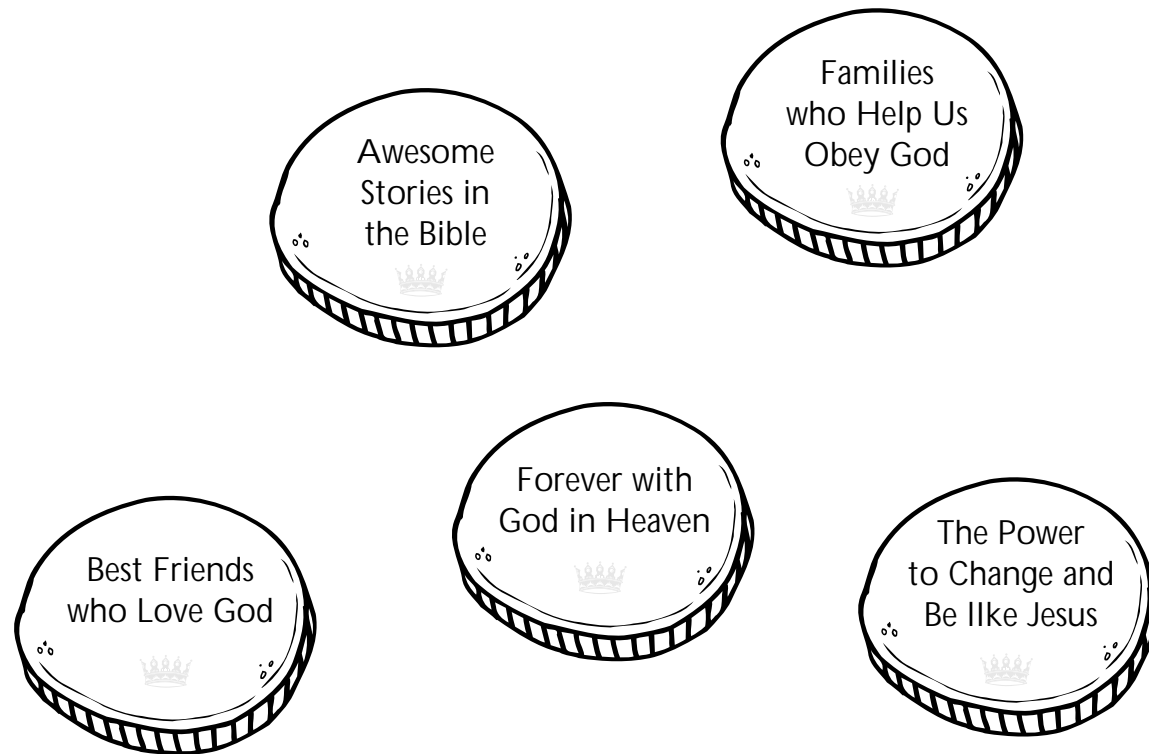

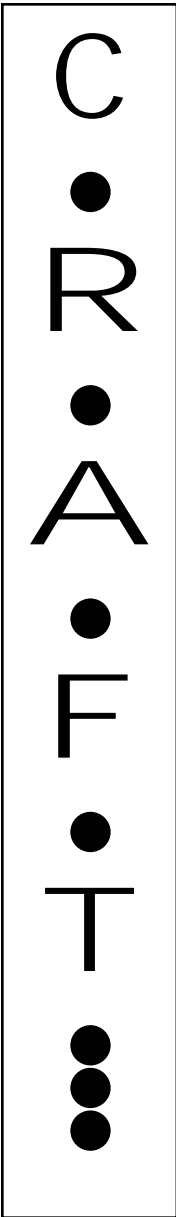

Hidden Treasure

Kingdom Treasures

The children will make treasure chests helping them to visualize Jesus' parable about the kingdom.

Materials

For each child:

- Kingdom Jewels from Preclass Activity
- glue stick or tape
- Easter grass or shredded construction paper
- items for chest: pieces of play jewelry, beads, candy coins, etc.

For the teacher:

- scissors
- crayons

Reproducible Pages:

- Page A, 1 copy for the teacher
- Page C, 1 copy for each child (on brown or beige card stock)

Preparation

1. Prepare a treasure chest for each child, see Figure A, as follows:
 - A. Cut out the treasure chests from the copies of Reproducible Page C.
 - B. Fold each chest along the dashed lines.
 - C. Cut the three slits indicated by the solid lines at the bottom of the chest.
2. Color and cut out the Kingdom Jewels from your copy of Reproducible Page A.
3. Make two samples of the treasure chest. Make one that is folded and cut, but not yet assembled, to be used during class as a demonstration model. Make a second sample of the completed craft.

Instructions

1. Introduce today's activity holding up your completed treasure chest: *In today's lesson we learn that the kingdom of God is like a treasure chest that is full of wonderful treasures! Show them your treasure chest and open it. Pull out the kingdom jewels and read the words written on them. Look at some of the treasures we can find in the kingdom treasure chest: friends, fun, family, food, prayer, the Bible. Each of you will make a treasure chest*

like this one. This will help you to remember the wonderful treasures that God has given us in the kingdom.

2. Distribute the treasure chests you prepared and glue sticks. Have the children construct their treasure chests as you demonstrate step-by-step, as follows:
 - A. Lay the chest down flat, and then fold under the bottom half chest, see Figure B.
 - B. Rotate the chest 180°. There should be four "panels" on the bottom half of the chest, as shown in Figure C.
 - C. Place glue on the second panel from the right, and then glue the right most panel on top of it. See Figure D.
 - D. There should now be three panels. Place glue on the right most panel. Glue the middle panel on top of it. See Figure E.
 - E. There should now be two panels left. Place glue on the right most panel. Then glue the left panel on top of it. See Figure F.
 - F. Glue the front tab to the right side of the chest to fold it completely. See Figure G. Fold down the top panels to close the treasure chest.
3. Distribute the Easter grass, envelopes, Kingdom Jewels and the decorative items. Have the children place the grass in their chests, and then place their Kingdom Jewels and decorative items inside. See Figure H.

Conclusion

Close with a prayer thanking God specifically for the kingdom treasures of family, fun, friends, prayer and the Bible.

Teacher Tips

- If you cannot reproduce Page C onto card stock, glue each copy to construction paper and then cut the treasure chests out.

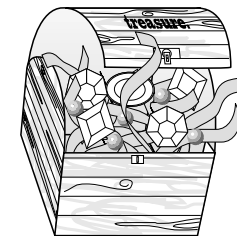

Hidden Treasure

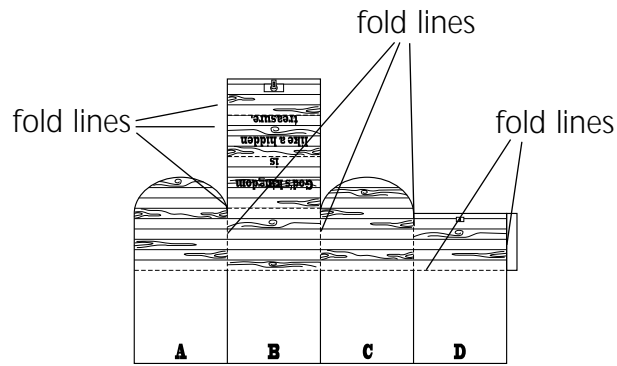

Figure A

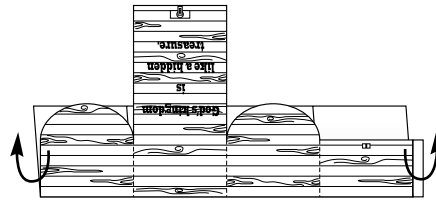

Figure B

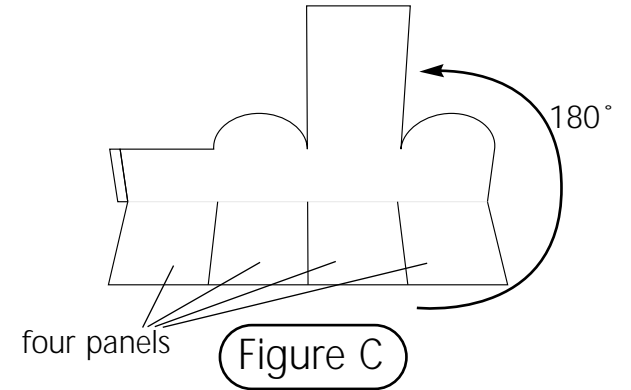

Figure C

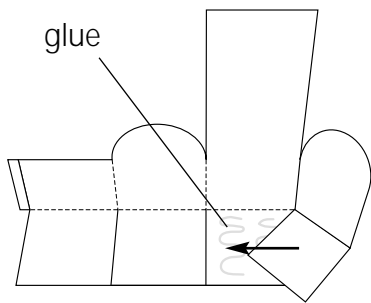

Figure D

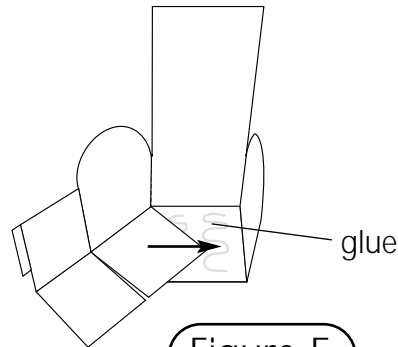

Figure E

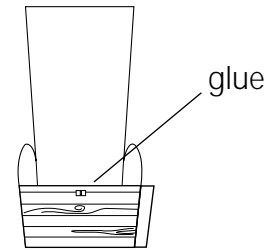

Figure F

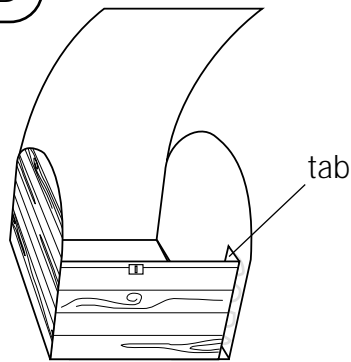

Figure G

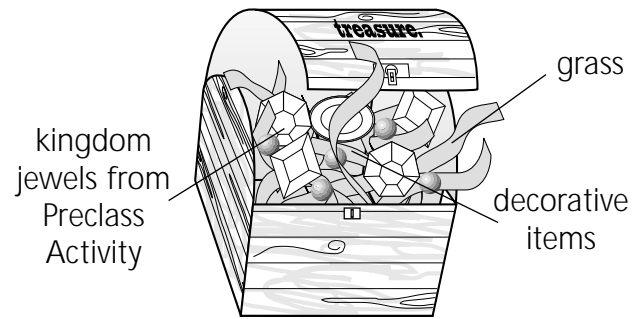

Figure H

SCR
IPT
URE
MEM
ORY

Hidden Treasure

Treasure Hidden

The children will learn the Scripture Memory Verse in this fun activity.

Scripture Memory Verse

"The kingdom of heaven is like treasure hidden in a field."
Matthew 13:44

Materials

For the teacher:

- 1 piece of costume jewelry or plastic coin

Preparation

Practice leading this activity.

Instructions

1. Introduce today's activity: *In your Bible Story today, you are learning about Jesus' parable of the hidden treasure. Jesus taught that the kingdom of heaven is like a treasure. In your Scripture Memory Verse, you will learn the first part of Jesus' parable.*
2. Show the Scripture Memory Verse to the children on the back of this Lesson Card. Say it three times as they follow. Point to the words as you say them. Have them say it together with you three more times. Ask for volunteers to say it together with you. Ask for volunteers to say it from memory.
3. Ask the children how they would feel if they found a treasure in the field behind their school. What would they do? Tell the children to say the verse together with you several times, each time using one of the following emotions and/or expressions: happy, excited, jumping up and down, surprised, in a whisper as if hiding something.
4. Have the children sit in a circle. Choose one child to begin by saying the first word of the verse, followed by the child to his right who says the next word, and so on until the verse is complete. Choose another child and do the same thing, only going to the left. Encourage the children to help each other if they forget a word.
5. Show the children the costume jewelry you brought. Explain that the children will all close their eyes and you will place this piece of jewelry behind one child (or beneath their chair). When the

children open their eyes, the child with the jewelry will begin by saying the first word of the Scripture Memory Verse and choose the child to his right or left to say the next word and pass the jewelry to that child. The children will pass the jewelry around as they say each word until the verse is complete. Take the jewelry back and repeat this activity for as many rounds as time permits.

Conclusion

Ask the children how it makes them feel to know that God's kingdom is like a treasure. Point out that the Bible is one of the most precious and valuable treasures that God has already given us. Close with a prayer thanking God for all the special treasures of the kingdom.

Teacher Tips

- Think of additional ways to do this passing activity.

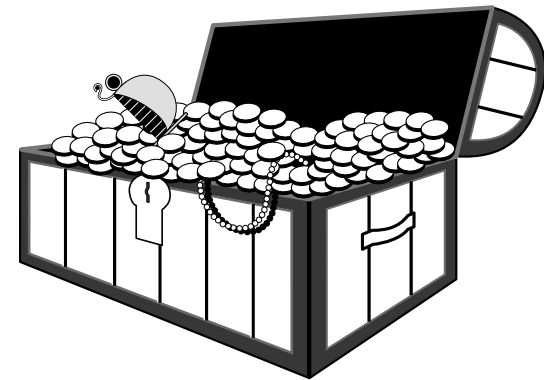

Hidden Treasure

SCR
IPT
URE
MEM
ORY

“The kingdom of heaven is like
treasure hidden in a field.”

Matthew 13:44



Lesson Objectives

- The children will participate in the parable of the hidden treasure.
- The children will state that God's kingdom is a treasure.
- The children will state one thing of theirs that God's kingdom is more valuable than.

Lesson Text

Matthew 13:44

Scripture Memory Verse

"The kingdom of heaven is like treasure hidden in a field."
Matthew 13:44

Lesson Plan

Greeting and Registration

Preclass Activity: Treasure Island

Welcome and Singing

Centers:

Life Application: Treasure Hunt

Game: Find the Kingdom

Bible Skills: Matthew's Treasures

NOTE: Allow time for a snack.



pre
class

ACTIVITY

Treasure Island

The children will review this week's Bible Story as they complete this treasure hunt.

Materials

For each child:

- fine-tip markers or colored pencils
- pencil

Reproducible Pages:

- Page D, 1 copy for each child (optional - on brightly colored paper)

Preparation

Complete the activity on your copy of Reproducible Page D. This will be your Answer Key.

Instructions

1. Greet the children as they arrive. Remind them that this week they are learning about Jesus' parable of the hidden treasure. Explain that their activity will take them on a treasure-seeking adventure.
2. Distribute the copies of Reproducible Page D and pencils. Encourage the children to work with a partner. Pair those who did not hear this week's Bible Story with those who did.
3. Circulate among the children to offer help and encouragement. Assign adult assistants to work with new or visiting children who may not be familiar with the Bible.

Teacher Tips

- Create a Treasure Island atmosphere by playing "island" style music, covering the tables with bright tablecovers and offering "tropical" snacks.
IMPORTANT: Obtain parental permission before giving food to the children.
- For a real treasure hunt, adapt your activity area and the activity on Reproducible Page D to an actual treasure hunt with hidden clues and a hidden treasure.

LIFE APPLICATION

Treasure Hunt

The children will review this week's Bible Story as they think of the value of God's kingdom in their lives.

Materials

For the teacher:

- 1 large box (suit coat size or larger)
- a photo of a family and/or friends
- Bible
- game or toy
- stickers
- bandages
- gold coin chocolates (optional)

Preparation

1. Place the photo, Bible, game, stickers, bandages and candy (if available) in the box.
2. When you arrive in your class activity area, choose a place to hide the box.
3. Practice leading this activity.

Reviewing the Bible Story

Open your Bible to Matthew 13:44. Remind the children that they are learning about Jesus' parable of the hidden treasure. Read Matthew 13:44 to them. Ask for volunteers to read it together with you.

- *What did Jesus say that the kingdom of heaven is like? (a treasure hidden in a field)*
- *What did Jesus say that a man did when he found it? (hid it again)*
- *What did Jesus say that the man sold? (all he had)*
- *Why did Jesus say that the man sold all he had? (He had to buy the field with the treasure hidden in it.)*

Life Application

Imagine that one day after school you find a backpack on the street. You notice that inside there is a _____ (fill blank with an item highly valued by first and second graders) that you have been searching for. It sells in some stores for more than a hundred dollars! On the backpack, there is a name and a phone number.

You take it home and tell your parents. They help you call the owner who says that their child lost that backpack last week. You ask about the (object) inside. The owner says that you can keep it, but they ask that you return the backpack. You offer to give them some money, but the owner says not to worry about it. You cannot believe it!

Ask the children how they would feel if this really happened to them. Explain that in Jesus' parable, the man found a treasure hidden in a field, but it was not his field. He decided that the treasure was worth everything he had, so he sold everything to buy that field—and the treasure hidden inside it!

Tell the children that hidden somewhere close by is a box with some special "kingdom" treasure inside. Have the children look for the box as a group. When they find the box, talk about the value of each item using the guide below for ideas:

Item	Special kingdom Treasure Value
Photo of family or friends	God gives us special people to take care of us, protect us, and help us.
Bible	God gives us the Bible to teach us about his awesome power and love. The Bible teaches us all about Jesus and how to love and obey God.
Bandages	God gives us help when we need it.
Game or Toy; Stickers	God gives us friends and ways to have fun.
Candy	God wants us to be as excited about his kingdom as we are about our favorite candy!

Conclusion

Ask the children to think about the things in the box. Then ask the children to fill in the blank: God's kingdom is more valuable to me than my _____. Begin by doing this first with your own answer such as: television, car, all your money, etc. Do not force the children to share. Close with a prayer thanking God for all the very special treasures of the kingdom.

Teacher Tips

- Embellish the box or find a treasure chest to use for this activity.



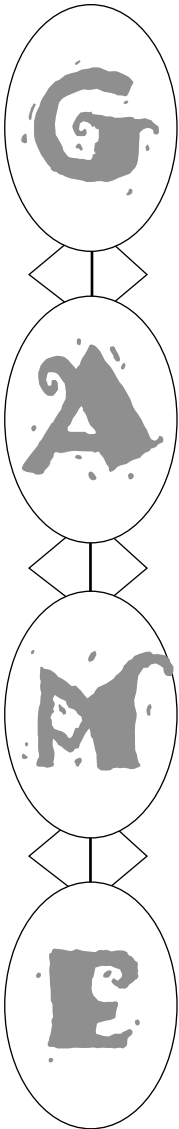

Find the Kingdom

The children will review important ideas from this week's lesson in this memory game.

Materials

For the teacher:

- scissors
- glue stick
- 32 index cards, 3" x 5"

Reproducible Pages:

- Page E, 4 copies for the teacher

Preparation

1. Cut out the cards from all your copies of Reproducible Page E and glue to the index cards.
2. Practice leading this activity.

Instructions

1. Introduce today's activity: *In the Bible Story this week, we learned about how Jesus said that the kingdom of heaven is like a hidden treasure. It is very valuable, so people should look hard to find it. We are going to play a game where we search for the kingdom like it is a hidden treasure.*
2. Show the children the cards that you prepared. Explain that on each card is written one of the treasures of God's kingdom. Show them the cards that have "king" and "dom." Explain that when they find these two cards, game play stops and both teams count up their points.
3. Divide the children into two teams. Mix the cards and place them face down in four rows of eight. Choose a team to begin. The teams will choose a child to turn over two cards. When a child finds a match, his team receives the points written on the cards. Players do not take another turn for finding a match.
4. When a child turns over "king" and "dom" together, they have found the kingdom and game play stops. Both teams must add up their points to see who the winner is.
5. Play as many rounds as time permits.

Conclusion

Ask the children what they think is the most special thing about God's kingdom to them. Close with a prayer thanking God for his very special kingdom.

Teacher Tips

- Reproduce Page E on brightly colored, heavy paper and laminate to eliminate the need for index cards and create a more durable material.
- Use these cards for extra activities.



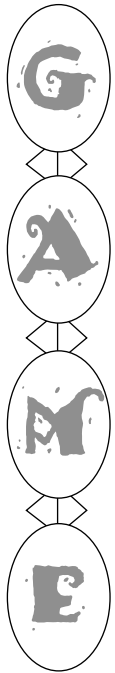

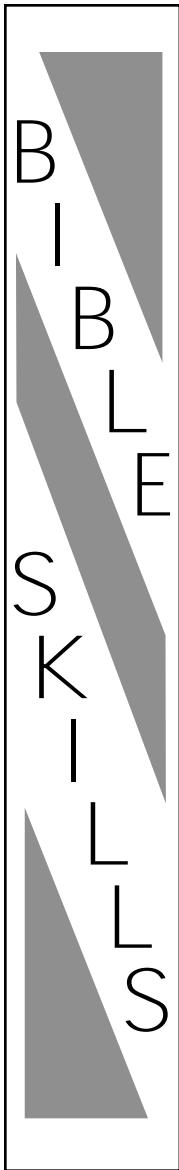

Matthew's Treasures

The children will practice looking up verses about kingdom treasures in the book of Matthew.

Materials

For each child:

- 1 envelope
- pencil

For the teacher:

- scissors
- pen

Reproducible Pages:

- Page F, 1 copy for each child

Preparation

1. Cut out the bookmarks from the copies of Reproducible Page F for each child and place in an envelope.
2. Mark your Bible with the bookmarks from your copy of Reproducible Page F.
3. Practice leading this activity.

Instructions:

1. Introduce today's activity: *In your Bible Story this week you learned about Jesus' parable of the hidden treasure. Jesus taught the people that the kingdom of heaven is like a treasure hidden in a field. When a man found it, he went and sold all he had so that he could buy the field and have the treasure. The Bible is full of scriptures that describe the treasures of God's kingdom. In your activity today, you will practice looking up these verses.*

2. Distribute the envelopes that you prepared and have the children write their names on them. Tell the children that on each bookmark is a scripture reference of a verse about a treasure of God's kingdom. Help the children each find a partner. Have the children look up the different verses and place the bookmarks in each one. When all the children have found the verses, go through each one and read them as a group. Use the list on the back of this Lesson Card as a guide.
3. Have the children take out their bookmarks and place them back in their envelopes. Collect all the Bibles. Hide each one of your bookmarks inside three of the children's Bibles. Give each pair of children a Bible and have them find the bookmark and then the reference.
4. Circulate among the children to offer help and encouragement.

Conclusion

Ask the children which of these verses they liked most and why. Close with a prayer thanking God for all the treasures of the kingdom.

Teacher Tips

- Think of ways to reinforce or embellish these bookmarks.



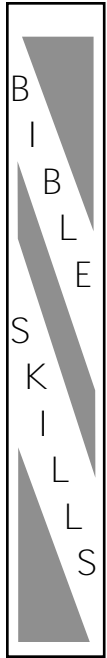

Hidden Treasure

Matthew's Treasure

Matthew 6:19-21

"Do not store up for yourselves treasures on earth, where moth and rust destroy, and where thieves break in and steal. But store up for yourselves treasures in heaven, where moth and rust do not destroy, and where thieves do not break in and steal. For where your treasure is, there your heart will be also."

Matthew 13:44

"The kingdom of heaven is like treasure hidden in a field. When a man found it, he hid it again, and then in his joy went and sold all he had and bought that field."

Matthew 19:21

Jesus answered, "If you want to be perfect, go, sell your possessions and give to the poor, and you will have treasure in heaven. Then come, follow me."



Core/Preclass 1 copy for each child
Core/Craft 1 copy for the teacher

R
E
P
R
O
D
U
C
I
B
L
E
P
A
G
E
A

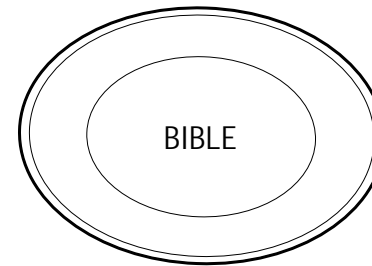
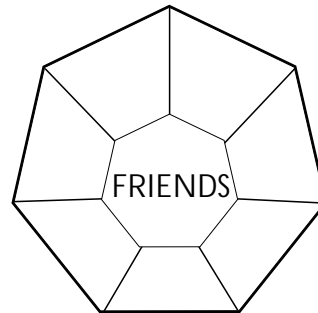
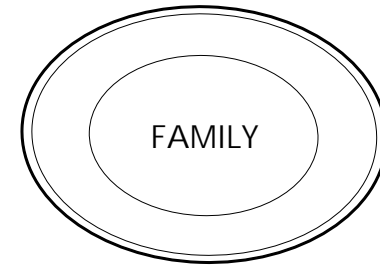
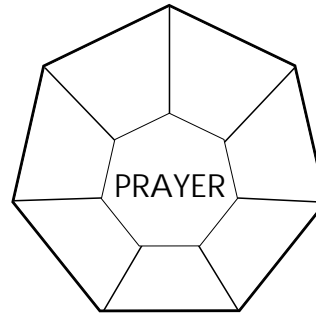
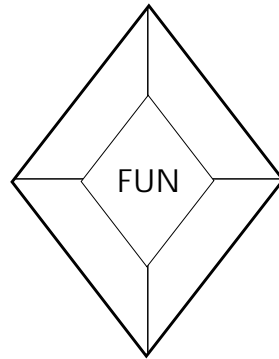

kingdom jewels



Core/Bible Story

1 copy for the teacher (on yellow or gold paper)

R
E
P
R
O
D
U
C
I
B
L
E

PAGE
B

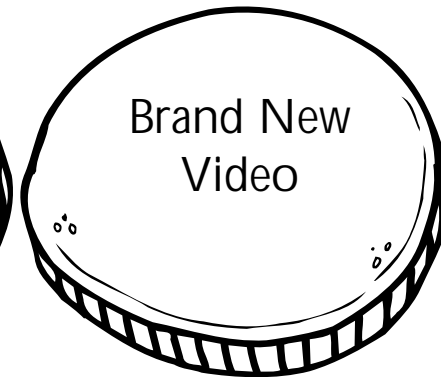
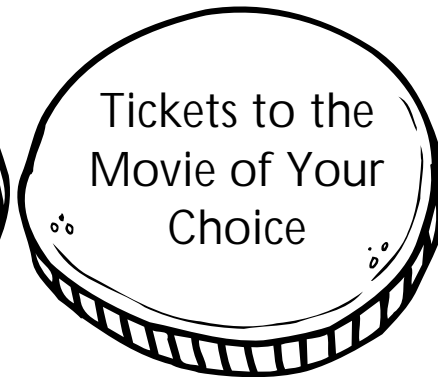
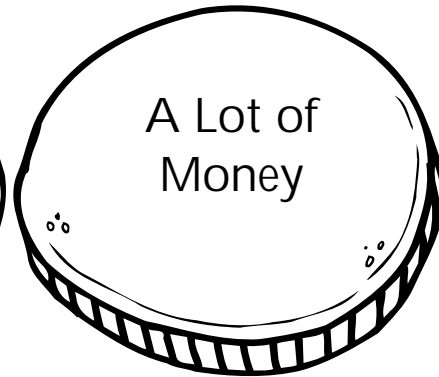
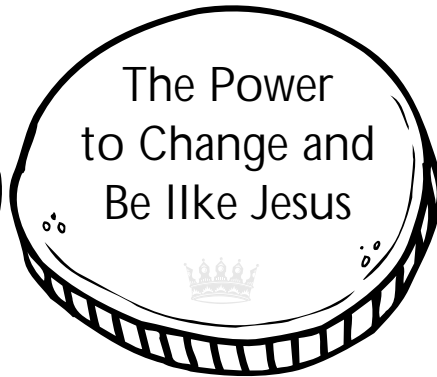

Core/Craft

1 copy for each child (on brown or beige card stock)

R
E
P
R
O
D
U
C
I
B
L
E

PAGE

C

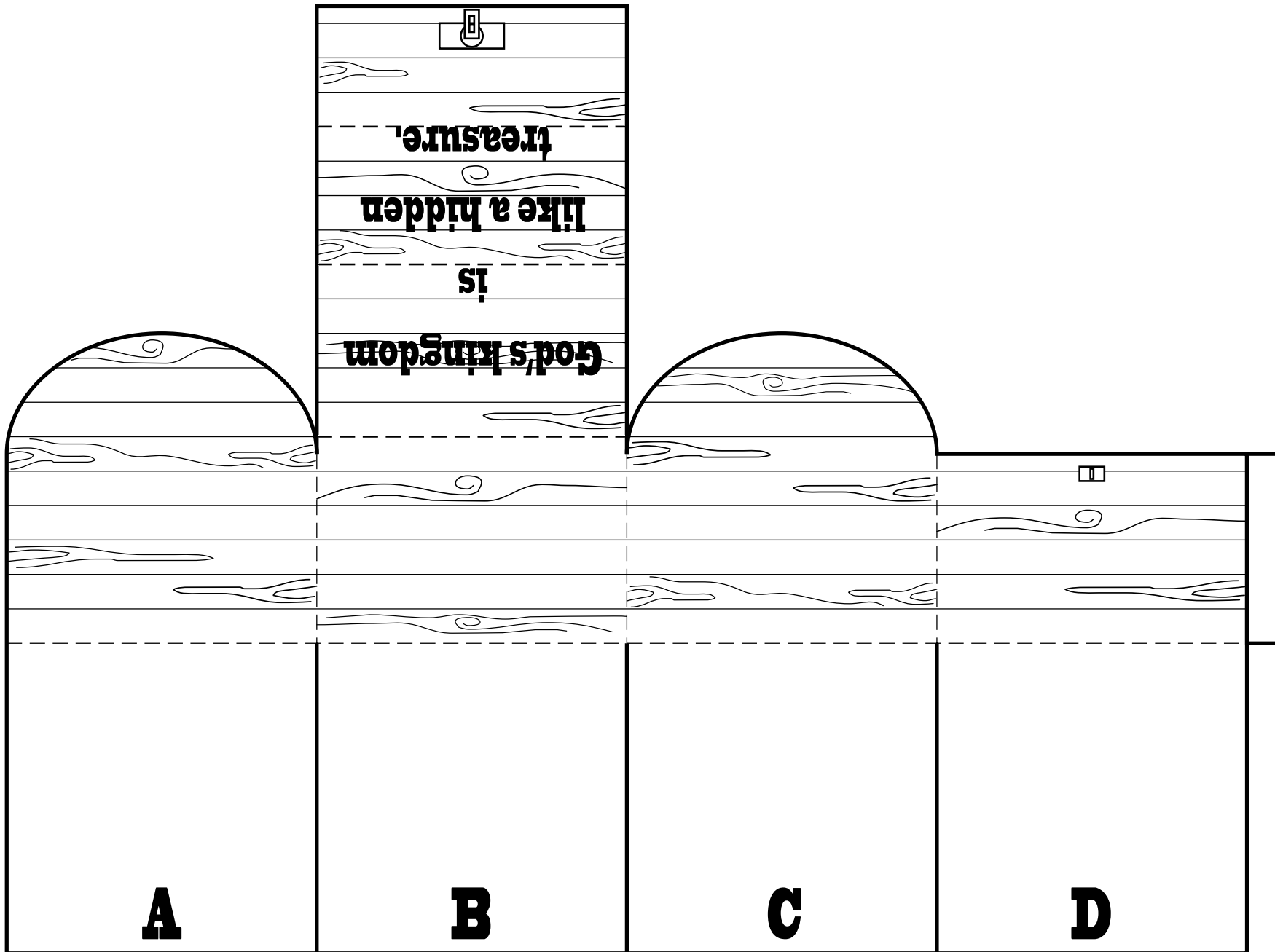

A

B

C

D



This page intentionally left blank



Supplement/Preclass

1 copy for each child (optional—brightly colored paper)

Name _____

R
E
P
R
O
D
U
C
I
B
L
E
P
A
G
E
D

Treasure Island

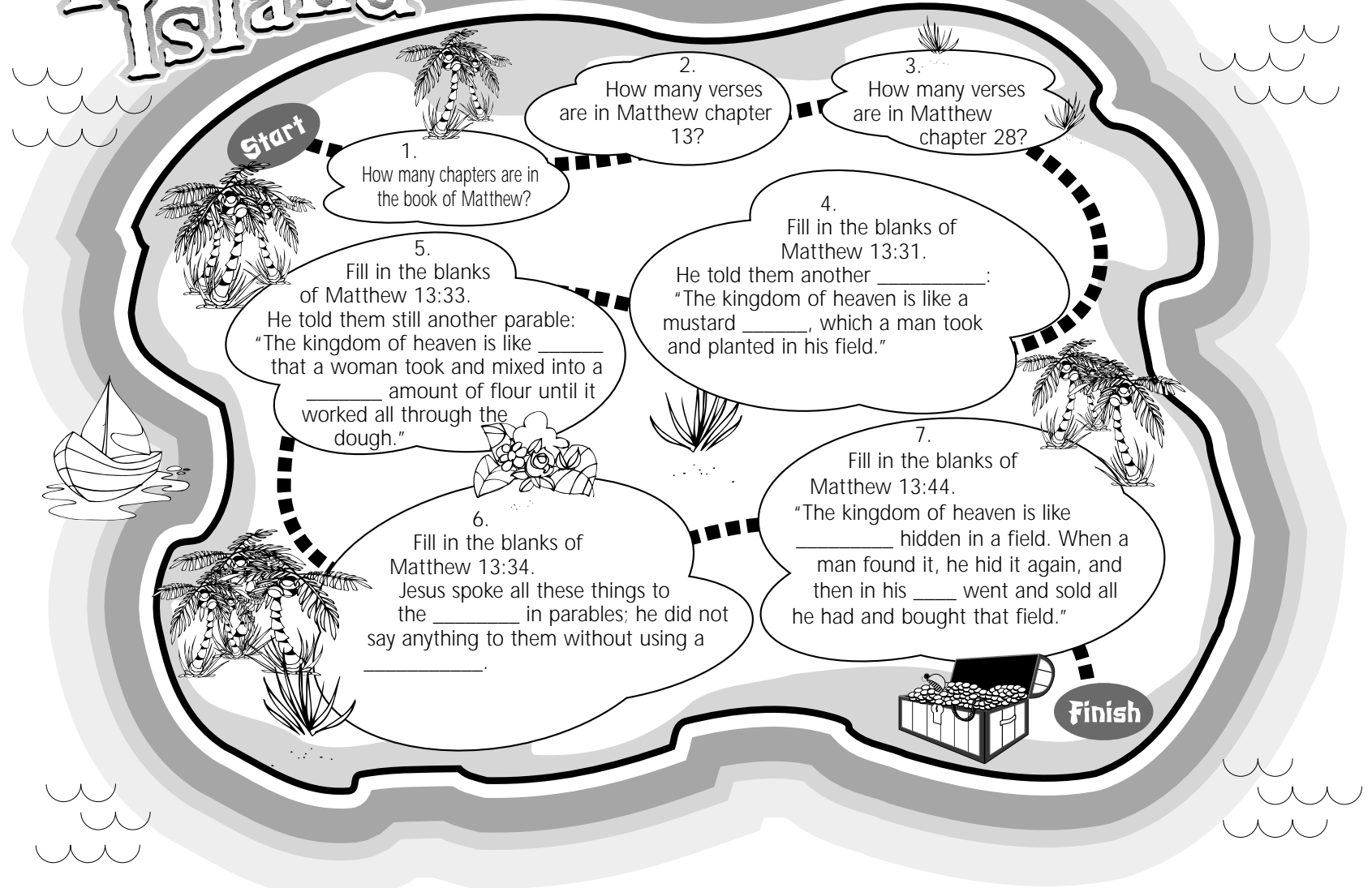

Start

1. How many chapters are in the book of Matthew?

2. How many verses are in Matthew chapter 13?

3. How many verses are in Matthew chapter 28?

5. Fill in the blanks of Matthew 13:33.
He told them still another parable: "The kingdom of heaven is like _____ that a woman took and mixed into a _____ amount of flour until it worked all through the dough."

4. Fill in the blanks of Matthew 13:31.
He told them another _____: "The kingdom of heaven is like a mustard _____, which a man took and planted in his field."

6. Fill in the blanks of Matthew 13:34.
Jesus spoke all these things to the _____ in parables; he did not say anything to them without using a _____.

7. Fill in the blanks of Matthew 13:44.
"The kingdom of heaven is like _____ hidden in a field. When a man found it, he hid it again, and then in his _____ went and sold all he had and bought that field."

Finish



R
E
P
R
O
D
U
C
I
B
L
E
P
A
G
E
E

Supplement/Game
4 copies for the teacher

Parables
Lesson 3

K-I-N-G	5 Family	10 Bible	20 Love
D-O-M	5 Friends	10 Prayer	20 Jesus



Supplement/Bible Skills
1 copy for each child

R
E
P
R
O
D
U
C
I
B
L
E
P
A
G
E
F

Matthew 6:19-21	Matthew 13:44	Matthew 19:21
-----------------	---------------	---------------

