

Love

Lesson Objectives

- The students will use the Bible to describe love.
- The students will state that love never fails.
- The students will explain one way that they will love someone this week.

Lesson Text

1 Corinthians 12:31-13:13

Scripture Memory Verse

Love is patient, love is kind. It does not envy, it does not boast, it is not proud.

1 Corinthians 13:4

Lesson Plan

Greeting and Registration

Preclass Activity: Read Between the Lines

Welcome and Singing

Centers:

Bible Story: Love Story

Craft: Painted Love

Scripture Memory: Love Is...

NOTE: Allow time for a snack.

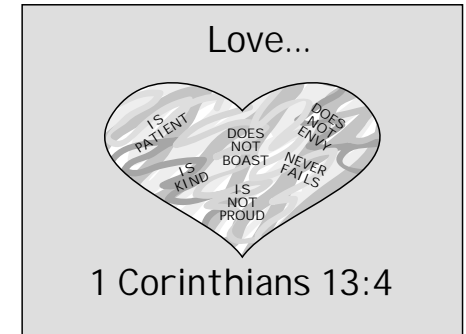

P
R
E
•
C
L
A
S
S

Love

Read Between the Lines

The students will preview today's lesson as they complete this activity.

Materials

For each student:

- pencil

Reproducible Pages:

- Page A, 1 copy for each student

Preparation

Complete the activity on your copy of Reproducible Page A.

Instructions

1. Greet the students as they arrive. Tell them that in today's lesson they will be learning about Paul's letter to the Corinthians where he defines and describes godly love. Explain that in today's Preclass Activity they will look up 1 Corinthians 13:4-8 and fill in the blanks as they look at the Bible's definition of love.
2. Distribute the copies of Reproducible Page A and pencils. Encourage the students to work with a partner or small group.
3. Circulate among the students to offer help and encouragement.
4. For the students who finish early, have them write their own definition of love on the backs of their pages.

Teacher Tips

- Look for opportunities to encourage students who demonstrate the qualities of love during this activity, e.g. patience, kindness, unselfishness, humility, etc.

Reading Between the Lines

Love is patient, love is kind. It does not envy, it does not boast, it is not proud. It is not rude, it is not self-seeking, it is not easily angered, it keeps no record of wrongs. Love does not delight in evil but rejoices with the truth. It always protects, always trusts, always hopes, always perseveres. Love never fails.

1 Corinthians 13:4-8

Instructions: Use the passage above to help you complete this activity. Fill in the blanks with the correct words from 1 Corinthians 13:4-8.

Love is patient and kind.

Love does not envy or boast.

Love is not proud, rude, self-seeking or easily angered.

Love keeps no record of wrongs.

Love does not delight in evil but rejoices with the truth.

Love always protects, trusts, hopes and perseveres.

Love never fails.

Love

Love Story

The students will learn about Paul's message to the Corinthians as they think about the definition of biblical love.

Materials

For the teacher:

- old pots and pans (optional)
- bells, horns or other simple instruments (optional)

NOTE: See Teacher Tips.

Preparation

Practice presenting this Bible Story with energy and enthusiasm.

Introducing the Bible Story

Open your Bible to 1 Corinthians 13. Tell the students that today's Bible Story comes from the New Testament book of 1 Corinthians. Explain to the students that this book is the first letter that Paul wrote to the church in Corinth. Like the letter to the Philippians, this letter is Paul's message to help the disciples be more like Jesus. In this letter, Paul helps explain and define what godly love is and how they can love each other. Ask the students to say some ways that they show their love to people. Encourage them that today they will learn some new ways to show love like Jesus.

Presenting the Bible Story

Read the following passage to the students. Tell them to listen very carefully to the things that love is and is not, as well as to the things that love does and does not do.

And now I will show you the most excellent way.

If I speak in the tongues of men and of angels, but have not love, I am only a resounding gong or a clanging cymbal. If I have the gift of prophecy and can fathom all mysteries and all knowledge, and if I have a faith that can move mountains, but have not love, I am nothing. If I give all I possess to the poor and surrender my body to the flames, but have not love, I gain nothing.

Love is patient, love is kind. It does not envy, it does not boast, it is not proud. It is not rude, it is not self-seeking, it is not easily angered, it keeps no record of wrongs. Love does not delight in evil but rejoices with the truth. It always

protects, always trusts, always hopes, always perseveres. Love never fails. (1 Corinthians 12:31-13:8)

- Have any of you ever heard an orchestra perform? How did it sound?
- Have you ever heard a clanging gong or a cymbal? How did it sound?
- Which sounded better: the orchestra or the gong?
- Have you ever heard someone speak in a different language than you?

The Bible teaches us that even if a disciple speaks different, beautiful languages, it would sound like a noisy, clanging gong if he did not have love. The Bible says that if a disciple has amazing faith, knows the Bible and gives money or possessions to the church, it means nothing if he does not have love! That is a very strong teaching. Paul knew that many religious people—even in the church—liked to get the attention of others by speaking in different languages or by showing their Bible wisdom. But Paul also knew that if those people did not do it out of love, it would mean nothing! This passage of the Bible is very important for us to understand if we want to love people like Jesus did.

Using the chart below, go through each of the words and make sure the students understand what they mean. Have the students give examples from their own lives of these different ideas.

Patient—waiting for someone or something without getting a bad attitude

Kind—doing and saying things that make others feel special; having good manners

Envy—wanting something that another person has so much that it makes you not like the person

Boast—telling others that you are the best and better than others

Proud—thinking you are better than others; thinking that you do not need help or advice; thinking that you know what is best

Rude—saying and doing things that interrupt or make others feel uncomfortable; not showing good manners

Self-seeking—wanting things for yourself and thinking about yourself more than about others



3rd and 4th Grades

Love

- Easily angered**—being quick to get angry or mad at others
Delight in evil—having fun doing things that hurt others or yourself
Rejoices in the truth—being happy when you or others do the right thing
Always protects—always looking for ways to take care of and defend the ones you love
Always trusts—always believing that God is in control and thinking the best of others
Always hopes—always thinking the best and praying about people you love
Always perseveres—never giving up on people; giving people lots of chances to change

What Do You Hear?

Tell the students that you are going to read these words again and pause after each one. If the words describe something that love is or does, then the students should make the sound of a trumpet. If the words describe something that love is not or does not, then the students should make the sound of a crashing cymbal. Have the students practice their sounds so that the trumpet sounds pleasant and musical, and the crashing cymbal sounds unpleasant.

- Patient* (pause for the trumpet sound)
Kind (pause for the trumpet sound)
Envy (pause for the clanging sound)
Boast (pause for the clanging sound)
Proud (pause for the clanging sound)
Rude (pause for the clanging sound)
Self-seeking (pause for the clanging sound)
Easily angered (pause for the clanging sound)
Delight in evil (pause for the clanging sound)
Rejoices in the truth (pause for the trumpet sound)
Always protects (pause for the trumpet sound)
Always trusts (pause for the trumpet sound)
Always hopes (pause for the trumpet sound)
Always perseveres (pause for the trumpet sound)

Sharing with Others

Ask the students if they can think of someone who has trouble showing love to others and encourage them to share this story with them. Close with a prayer for the students to show this kind of godly love to their friends and families this week.

Teacher Tips

- If available, bring in pots and pans for the students to use to make “clanging” sounds, and some simple instruments (bells) for the students to use to make pleasant, musical sounds.



3rd and 4th Grades

C

R

A

F

T

Love

Painted Love

The students will make and paint hearts that highlight several attributes of godly love.

Materials

For each student:

- 1 piece of construction paper, 9" x 12"
- watercolor paint
- paintbrush
- small paper cup
- black marker
- invisible tape

For the teacher:

- scissors
- large writing surface

Reproducible Pages:

- Page B, 1 copy for each student

Preparation

1. Cut out the painting backgrounds from the copies of Reproducible Page B.
2. Make a heart stencil as follows:
 - A. Fold the construction paper vertically.
 - B. Draw a half of a heart shape approximately 4¾" long and 3¾" wide. See Figure A.
 - C. Cut out the heart for use as a stencil.
3. Fold each piece of construction paper in half vertically. Using your heart stencil, trace and cut out a heart for each student. Discard the hearts, keeping only the paper with the cutout. See Figure B.
4. Make a sample of the craft to show the students.
5. Prior to class, set up the work area as follows:
 - A. Cover the work surface with newspapers.
 - B. Place the watercolor paints, paint brushes and cups on the work surface.
 - C. Fill the cups ⅓ of the way with water.
6. Prior to class, draw a heart on the large writing surface. Write, "Love ..." above the heart, and write, "1 Corinthians 13:4" below the heart.

Instructions

1. Introduce today's activity as follows: *In today's lesson, you are learning what real love is.* Show the students your craft and read the words written on the heart. *In today's activity, you will make a heart painting just like this! This will help you remember how to show love to the people around you.*
2. Distribute the painting backgrounds. Have the students paint the backgrounds completely with paint. Have the students place their paintings aside to dry.
3. Distribute the construction paper with the heart cutout and black markers. Referring to the large writing surface, have the students write, "Love ..." at the top of their papers, and then write, "1 Corinthians 13:4" at the bottom. See Figure C.
4. After their paintings have dried, have the students tape their paintings to the back of the heart cutout, see Figure D.
5. Have them write their names on the front of their crafts.

Conclusion

Discuss with the students not only how important it is for us to love, but to also make sure others feel loved by us. Close with a prayer to love others as God loves us.

Teacher Tips

- Encourage the students not to paint thickly or it will take a long time to dry. Watercolor paint should dry in ten minutes or less.
- Some students might need help aligning their paintings before taping them in place.

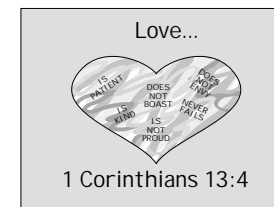

3rd and 4th Grades

Love

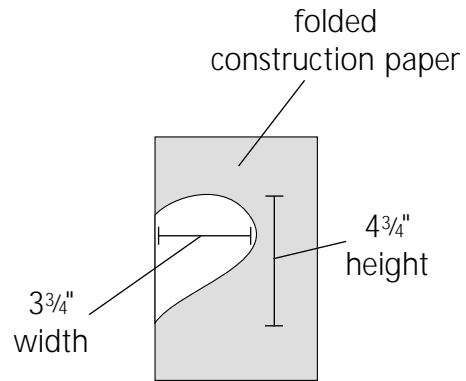

Figure A

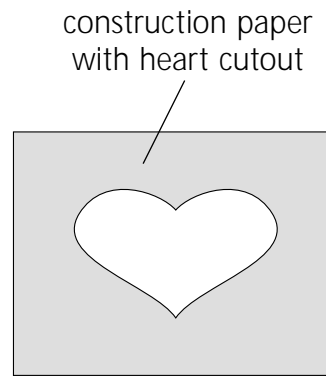

Figure B

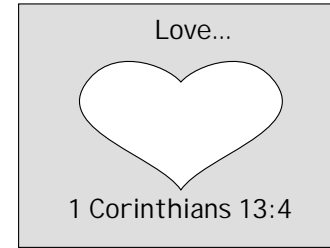

Figure C

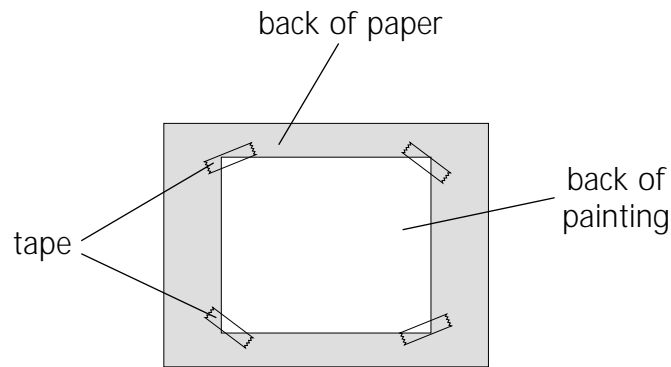
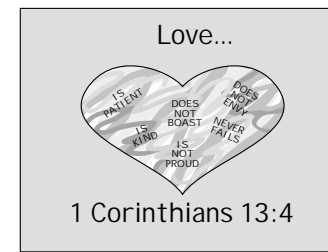

Figure D



Finished Craft

Love

Love Is...

The students will learn and memorize the Scripture Memory Verse through this rhythmic activity.

Scripture Memory Verse

Love is patient, love is kind. It does not envy, it does not boast, it is not proud.

1 Corinthians 13:4

Materials

For the teacher:

- 6 index cards, 5" x 7"
- pen

Preparation

1. Neatly print one of the following phrases on each index card, being careful to include the correct punctuation and capitalization:
 Love is patient,
 love is kind.
 It does not envy,
 it does not boast,
 it is not proud.
 1 Corinthians 13:4
2. Practice leading this activity.

Instructions

1. Introduce today's activity: *This week in your Bible Story you are learning about Paul's letter to the Corinthians in which he describes love. Paul explained in detail the characteristics of love—what love is and does. Paul wanted to help the disciples to be like Jesus in the way they treated each other, and he gave very specific examples to help them. In your Scripture Memory Verse today, you will learn five very important things about godly love.*
2. Show the students the Scripture Memory Verse on the back of this Lesson Card. Say it to them three times as they follow along silently. Ask them to say it together with you three more times. Ask for volunteers to come up and say the verse together with you.

3. Tell the students that they are going to say the verse in five different ways. Lead them in saying the verse in the following ways: softly, smiling, shaking someone's hand, giving hugs, on your knees.
4. Show the students the index cards you prepared. Explain that they will use these cards to come up with a special rhythm for this verse.
5. Read the phrases on the cards to the students and then distribute them evenly among the students so that everyone can participate.
6. The student(s) holding the first phrase will say the phrase to a beat such as clapping or snapping. The student with the next phrase will continue the beat and say the second phrase, and so on until the entire verse has been said to the beat set by the first student.
7. Collect and shuffle the cards and distribute them. Repeat Step 6, making sure that a new student starts with a new beat or rhythm. Do this as often as time permits.

Conclusion

Ask the students how it makes them feel to know that the Bible is so detailed and specific in explaining love. Make sure to point out that the Bible does not say that love is just a feeling—but rather it is a decision, a way of thinking and treating others which becomes a way of life. Close with a prayer thanking God for all the ways that he has shown his love to us.

Teacher Tips

- If necessary, start the first round by setting your own beat to give the students an example.

Love

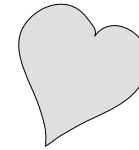
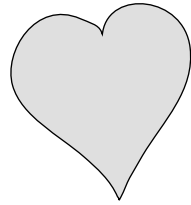

Love is patient, love is kind. It
does not envy,[♥] it does not
boast, it is not proud.

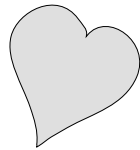

1 Corinthians 13:4

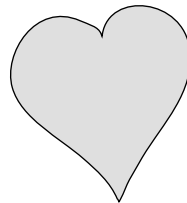
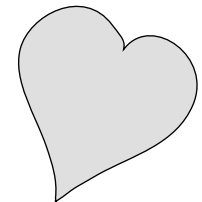

Lesson Objectives

- The students will use the Bible to describe love.
- The students will state that love never fails.
- The students will explain one way that they will love someone this week.

Lesson Text

1 Corinthians 12:31-13:13

Scripture Memory Verse

Love is patient, love is kind. It does not envy, it does not boast, it is not proud.

1 Corinthians 13:4

Lesson Plan

Greeting and Registration

Preclass Activity: Define-It Love

Welcome and Singing

Centers:

Life Application: Love in Action

Game: Show Me Love

Bible Skills: Where Is the Love?

NOTE: Allow time for a snack.

Define-It Love

The students will review this week's lesson as they display words and pictures that describe love.

Materials

For each student:

- pen or pencil
- crayons or markers
- glue stick
- scissors

For the teacher:

- 2 pieces of banner paper, 6'
- magazines pictures of people

Reproducible Pages:

- Page C, 1 copy for each student

Preparation

1. Along the top edge of one piece of banner paper, neatly print: "Love Is and Does...." Using your copy of

Reproducible Page C, neatly print the words that belong on this banner to show the students.

2. Along the top edge of the other piece of banner paper, neatly print: "Love Is NOT and Does NOT...." Using your copy of Reproducible Page C, neatly print the words that belong on this banner to show the students.
3. Cut out some pictures of faces or situations that illustrate 1 Corinthians 13:1-13, e.g. patient, kind, rude, boastful, easily angered, etc.

Instructions

1. Greet the students as they arrive. Remind them that they are learning about Paul's message to the Corinthians about love.

2. Show them the banners you prepared. Explain that they will write the correct words that belong on each banner using their copies of Reproducible Page C as a guide. They can illustrate their words by drawing or gluing pictures.
3. Distribute the copies of Reproducible Page C, pencils, crayons, scissors, and glue sticks.
4. Circulate among the students and encourage those who demonstrate patience, kindness, etc.

Teachers Tips

- Play contemporary Christian music during this activity.
- For small groups, use smaller pieces of paper or poster board.



3rd and 4th Grades

Love in Action

The students will review this week's Bible Story as they think of ways that they can show love this week.

Materials

For the teacher:

- 1 piece of cardboard, 7" x 7"
- 1 piece of cardboard, 1/2" x 3"
- brass fastener
- hole punch
- glue stick
- scissors

Reproducible Pages:

- Page D, 1 copy for the teacher

Preparation

1. Cut out and prepare the spinner using your copy of Reproducible Page D.
2. Read 1 Corinthians 12:31-13:13 to review this week's Bible Story.
3. Practice leading this activity.

Reviewing the Bible Story

Tell the students to open their Bibles to 1 Corinthians 13 and follow along as you read verses 1-13 to them aloud. When you are finished reading, ask them what they think is the hardest way for them to show love, using the definition of love in 1 Corinthians.

Tell the students to read the passage again with you, only this time out loud. Tell the students that each time the word "love" appears, you will replace it with the word "God." After you finish reading, do this again, replacing the word "love" with the word "Jesus." Explain that this passage shows us how God and Jesus want us to show love.

Life Application

Show the students the spinner you prepared. Tell them that they are going to take turns spinning the spinner and saying one way that they can show love to someone in their family using the definition they land on. Encourage the students to help each other think of ways if they need ideas. For the next round, have the students think of one way that they can show love to someone in school in the same manner. For a final round, have the students think of a way that they can show love to someone in their Bible class. Be prepared to share from your own life and offer ideas for students who have trouble applying this idea to their own lives.

Conclusion

Have the students sit in a circle. Ask them how it makes them feel to know that love never fails. Have each student say, "Love never fails." Close with a prayer thanking God that his love never fails.

Teacher Tips

- Do not force a student to share. Encourage students for their thoughts and ideas about how to love others.



Show Me Love

The students will review key ideas from this week's lesson as they play this version of charades.

Materials

For the teacher:

- scissors
- hat or bowl

Reproducible Pages:

- Page E, 1 copy for the teacher



Preparation

1. Cut out the words or phrases from your copy of Reproducible Page E. Fold them and place them in the hat or bowl.
2. Practice acting the words or phrases and be prepared to show the students your examples.



Instructions

1. Introduce today's activity: *In your Bible Story this week, you learned about Paul's message to the Corinthians about love. Paul wrote a letter to the disciples in the city of Corinth to help them be more like Jesus. One of the most important things that he taught them was about love—what love is and what it is not. Paul wanted the disciples to understand that even if we have fancy words and do impressive things for God, it does not matter if we don't have love. In today's game, you will think about the words from 1 Corinthians 13 that describe love and then act them out in a charade.*
2. Divide the students into pairs. Tell them that they will each take turns taking out a piece of paper from your hat and acting out the word or phrase that is written on it. When the other students think they know what it is, they must call out "Love is (or does) _____" or "Love is not (or does not) _____" followed by the word or phrase the students are acting out.
3. Review the basic rules of charades. The students may only use their bodies, hands and facial expressions to act out the words. They may not use words or sounds. They may also hold up the number of words on their piece of paper, e.g. three fingers for "delight in evil."



4. Choose the first charade and act it out for the students. Make sure that they understand not to just call out the word, but the entire statement as described in Step 2. For example, if you are acting out a charade for "Envy," the students must call out "Love does not envy" and not just the word "envy." Use the Answer Guide on the back of this Lesson Card to help you judge.
5. Choose a pair of students to begin. Make sure they understand the word(s) they are acting out. Give them a few moments to talk about how they want to act it out. Give them ideas if they need help.
6. When the other students have guessed the charade correctly, the students may sit down and the pair that guessed may take a turn to play. Play until every pair of students has had a chance to act out a charade.

Challenging Variations

- For large groups, you may prefer to divide the students into two teams and have the students act out their charade to their team. Keep track of times for a more competitive activity.
- Let ambitious and confident students act out the charades alone instead of with a partner.
NOTE: Many of the charades are more effectively acted out in pairs since they describe actions and attitudes between people.

Conclusion

Ask the students how it felt to act out these different aspects of love. Encourage them to try this game at home for a family devotional. Close with a prayer for the students to show their love at home and at school this week.

Teacher Tips

- If you are unfamiliar with the game of charades, ask someone who knows the game to help you learn it.

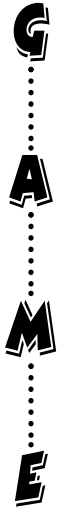

Show Me Love

Charade Answer Guide

Charade

Student Answer

Patient

Love is patient.

Kind

Love is kind.

Rejoices in the truth

Love rejoices in the truth.

Always protects

Love always protects.

Always trusts

Love always trusts.

Always hopes

Love always hopes.

Always perseveres

Love always perseveres.

Envy

Love does not envy.

Boast

Love does not boast.

Proud

Love is not proud.

Rude

Love is not rude.

Self-seeking

Love is not self-seeking.

Easily angered

Love is not easily angered.

Delight in evil

Love does not delight in evil.



3rd and 4th Grades

B
I
B
L
E
S
K
I
L
L
S**Where Is the Love?**

The students will practice looking up passages about love as they search for hidden surprises.

Materials

For each teacher:

- scissors
- extra Bibles

Reproducible Pages:

- Page F, 2 copies for the teacher (Optional - brightly colored, heavy paper)

Preparation

1. Cut out all the Bible page markers from both your copies of Reproducible Page F.
2. Practice leading this activity.

Instructions

1. Introduce today's activity: *In your Bible Story this week, you learned about Paul's message to the Corinthians about love. Paul wrote a letter to the disciples in the city of Corinth to help them be more like Jesus. One of the most important things that he taught them was about love—what love is and what it is not. Paul wanted the disciples to understand that even if we have fancy words and do impressive things for God, it does not matter if we don't have love. In today's activity, you will look up some verses in the book of Psalms in the Bible about God's love and then do some fun things as you find them.*
2. Tell the students to open their Bibles and find the book of Psalms.
3. Show the students the markers you prepared. Explain that there are two markers for each verse. Tell the students that you will hide these markers in their Bibles. They must find the marker in their Bible and then find the student who has the matching marker. Once they have found their partners, they will do what is written on their markers, e.g., give a hug, shake hands, give a high five, etc. and then try to be the first pair to find the verse on their markers.

NOTE: If you have fewer than twelve students, remove the extra markers. For example: if you have eight students in a group, remove two pairs. If there is an uneven number of students, choose an adult assistant to be a partner or have one student play alone.

4. Tell the students to remove any papers, markers or items already in their Bibles and set them aside for this activity. Collect the Bibles from the students and place the markers anywhere in their Bibles—they do not have to be placed in the same book as the reference they will be finding.
5. Have the students sit in a circle. Place their Bibles in the middle of the circle. On your word, have them carefully take their Bibles and look for their markers hidden inside. After they have located the student who has the same marker, they must do what is written on their markers. The first pair to find their verse is the winner. Have the students go around and read their verses to the group. These are provided for you on the back of this Lesson Card.
6. Collect the markers and Bibles and play as many additional rounds as time permits.

Conclusion

Ask the students to choose one word to describe God's love for them. Close with a prayer thanking God for his awesome love for us.

Teacher Tips

- Circulate among the students to offer help and encouragement.
- Provide bags for students to use if they have a lot of papers in their Bibles to remove.
- Reproduce Page F on brightly colored, heavy paper and laminate for a more durable material.
- Do not force a student to give a hug. Suggest that they shake hands or smile if they are not comfortable.



3rd and 4th Grades

Where Is the Love?**Psalm 23:6**

Surely goodness and love will follow me
all the days of my life,
and I will dwell in the house of the LORD
forever.

Psalm 26:3

For your love is ever before me,
and I walk continually in your truth.

Psalm 85:10

Love and faithfulness meet together;
righteousness and peace kiss each other.

Psalm 94:18

When I said, "My foot is slipping,"
your love, O LORD, supported me.

Psalm 100:5

For the LORD is good and his love endures forever;
his faithfulness continues through all generations.

Psalm 108:4

For great is your love, higher than the heavens;
your faithfulness reaches to the skies.

Reading Between the Lines

Name _____

Love is patient, love is kind. It does not envy, it does not boast, it is not proud. It is not rude, it is not self-seeking, it is not easily angered, it keeps no record of wrongs. Love does not delight in evil but rejoices with the truth. It always protects, always trusts, always hopes, always perseveres. Love never fails.

1 Corinthians 13:4-8

Instructions: Use the passage above to help you complete this activity. Fill in the blanks with the correct words from 1 Corinthians 13:4-8.

Love is patient and _____.

Love does not _____ or _____.

Love is not _____, _____, _____ or _____.

Love keeps no _____.

Love does not _____ but rejoices _____.

Love always _____, _____, _____ and _____.

Love never _____.

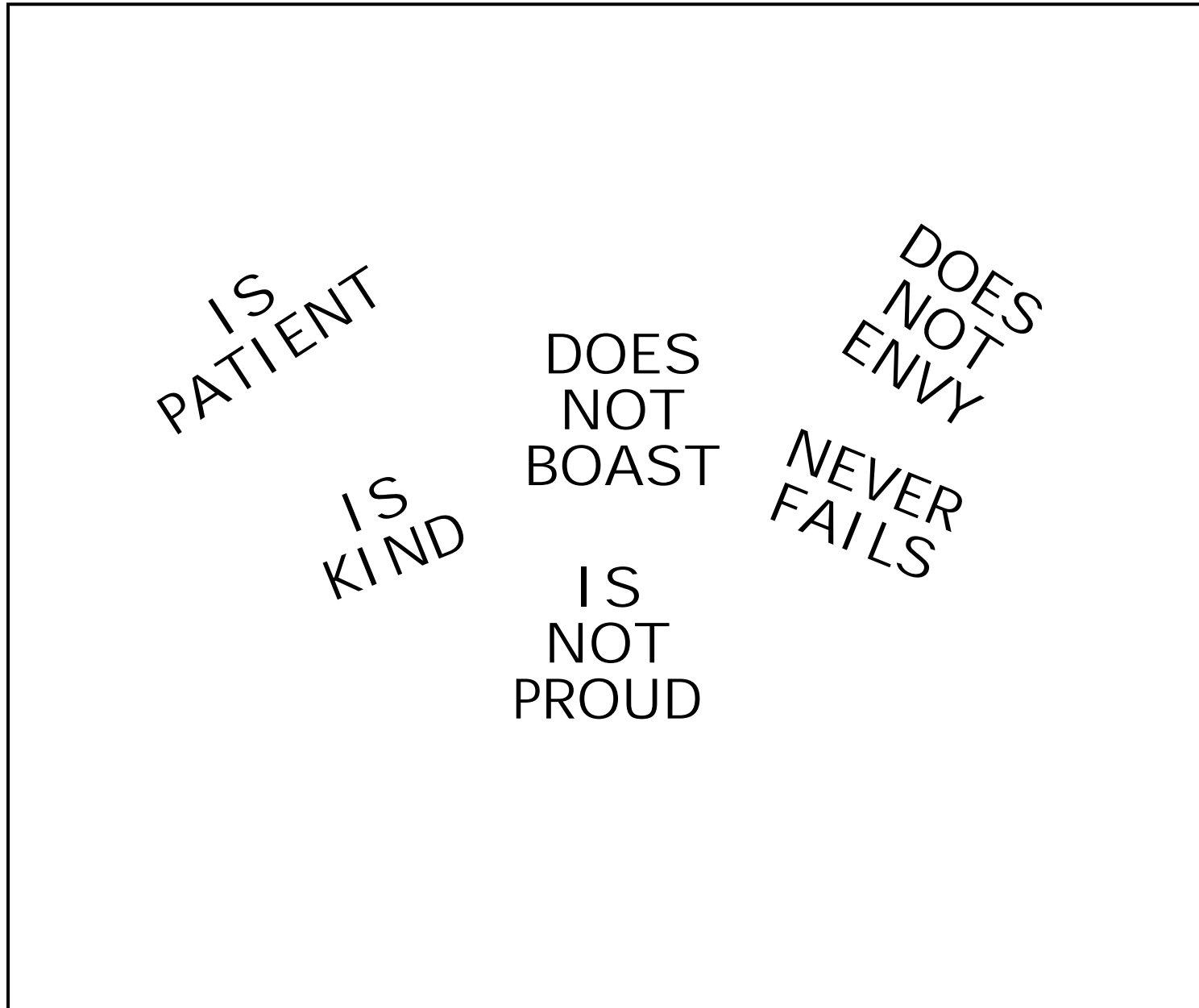

painting background



3rd and 4th Grades

Name _____

Define-It Love

Instructions: Using the examples below, neatly print the following words onto the large banners that your teacher has prepared. Make sure you put the correct words on the correct banner. Then draw (or cut and glue) pictures for those words.

Love Is or Does...

Patient
Kind
Rejoices in the truth
Always Protects
Always trusts
Always hopes
Always perseveres

Love Is NOT or Does NOT...

Envy
Boast
Proud
Rude
Self-seeking
Easily angered
Delight in evil



3rd and 4th Grades

Supplement/Life Application

1 copy for the teacher

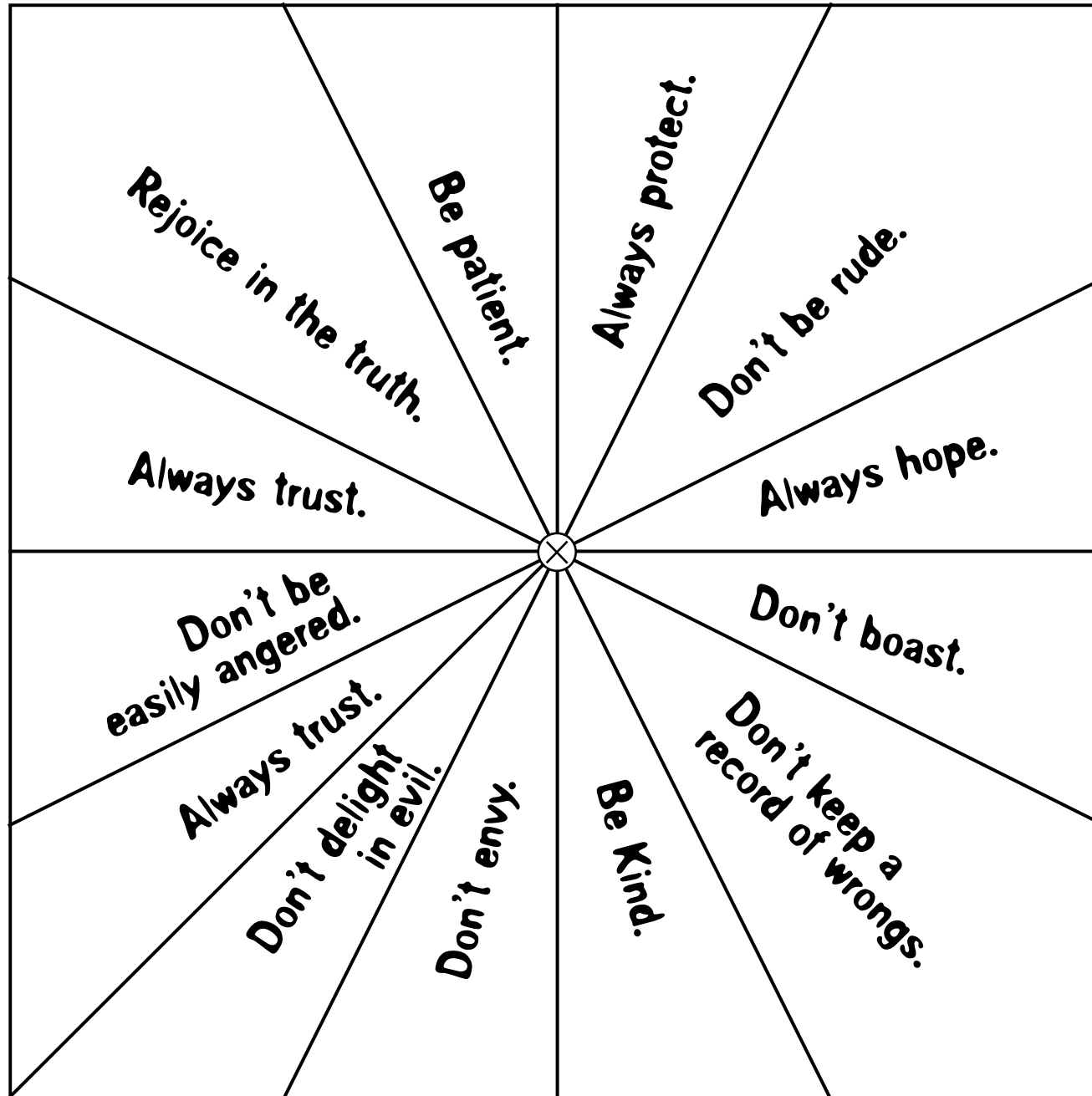

Instructions

1. Cut out the spinner board and pointer.
2. Mount and glue the spinner board to the cardboard.
3. Punch holes in both the pointer and the board where indicated with the "X."
4. Feed the brass fastener through the holes in the pointer and the board and open the flaps behind the spinner board to secure. Make sure the pointer can spin freely on the board.



3rd and 4th Grades

Patient	Envy
Always Protects	Rude
Always perseveres	Delight in evil
Proud	Rejoices in the truth
Easily angered	Always hopes
Kind	Boast
Always trusts	Self-seeking

