

The Church Grows

Lesson Objectives

- The students will hear the story of how the early church grew.
- The students will name one way disciples help the church.
- The students will name one way they will be more like Jesus.

Lesson Text

Acts 3-5

Scripture Memory Verse

And the Lord added to their number daily those who were being saved.

Acts 2:47

Lesson Plan

Greeting and Registration

Preclass Activity: Record Growth

Welcome and Singing

Centers:

Bible Story: The Church Grows

Craft: First Century Film

Scripture Memory: Building Blocks

NOTE: Allow time for a snack.



P
R
E
•
C
L
A
S
S

The Church Grows

Record Growth

The students will preview today's lesson by preparing pictures to be used later in their Bible Story.

Materials

For each student:

- crayons and markers
- scissors
- 1 envelope

Reproducible Pages:

- Page A, 1 copy for each student

Preparation

Complete the activity using your copy of Reproducible Page A.

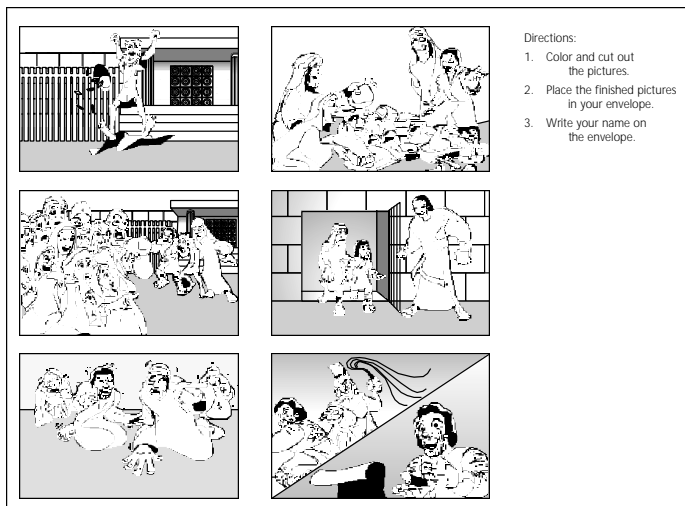

Instructions

1. Greet the students as they arrive. Explain that today's lesson tells about how the early church grew. Tell them that they will make pictures to use during today's Bible Story.
2. Distribute the copies of Reproducible Page A, crayons, markers and scissors. Tell the students to color and cut out the pictures. When they have finished, distribute the envelopes and have them place their pictures inside. Make sure they write their names on their envelopes.
3. Circulate among the students to offer help cutting out pictures.
4. For students who finish early, let them make an extra set for students who arrive late.
5. Collect their envelopes and give them to the Bible Story teacher.
6. Give your sample to the Bible Story teacher.

Teacher Tips

- For large classes, organize the envelopes in alphabetical or numerical (by registration tags) order before giving them to the Bible Story teacher.
- If possible, play the Upside Down soundtrack, available from DPI, for the students during this activity.

The Church Grows

The Church Grows

The students will participate in today's Bible Story as they learn about the growth of the early church.

Materials

For each student:

- envelope prepared in Preclass
- glue stick
- pencil

For the teacher:

- pictures from the Preclass teacher
- robe
- headpiece

Reproducible Pages:

- Page B, 1 copy for each student

Preparation

1. Practice telling the story with enthusiasm, using the pictures from Preclass and your copy of Reproducible Page B.
2. Prepare your costume to look like a first century disciple.

Introducing the Bible Story

NOTE: Ask your assistant to introduce the Bible Story and to introduce you as John.

Open your Bible to Acts 3. Explain that today's Bible Story comes from Acts 3-5 and will be presented by a special visitor, the apostle John. He will tell about the early growth of the church.

Distribute the copies of Reproducible Page B, the envelopes and glue sticks to the students. Tell them that each picture tells about something from today's story. They will glue them on the correct space on their pages as you speak about each one.

Presenting the Bible Story

Hello, my name is John. I was a very close friend to Jesus. He chose me and the other apostles to go and tell everyone about him. Today, I want to tell you about all the awesome ways that God helped the early church to grow.

Do you remember what happened on Pentecost? (Take one or two brief responses.) Many amazing and exciting things happened after Pentecost, too! All the believers met together in the temple

courts. We praised God and shared the good news about Jesus with the people. God kept bringing people to us that wanted to know God and be baptized. Every day more people were saved.

One day, Peter and I were going up to the temple for prayer. As we neared the temple gate called Beautiful, we met a beggar. This wasn't an ordinary beggar. He was crippled from birth, which means that he had never walked in his life. He sat there day after day begging for money from everyone who entered the temple. He asked Peter and me for money. Peter said, "Silver or gold I do not have, but what I have I give you. In the name of Jesus Christ of Nazareth, walk." Peter took him by the hand and helped him up. Instantly the man's feet and ankles were strong and he began to walk! He was jumping around and praising God. Can you imagine how excited he must have been? Direct the students to find and glue the correct picture in the box next to Acts 3—a beggar healed.

Other people saw what happened and a crowd began to gather. Peter saw the crowd and began to preach to them about Jesus. He told them that the beggar was healed through the power of Jesus and then he went on to tell the crowd about Jesus. Peter instructed them to repent and turn to God so that their sins could be forgiven and they could feel refreshed by God. Have the students glue the correct picture in the box next to Acts 3—Peter preaches.

Pause and look very serious. The religious leaders and rulers heard about what happened. They were upset that we were preaching about Jesus and the resurrection of the dead. They arrested Peter and me! We spent the night in jail and the next day we had to appear before the religious officials. They asked us how we healed the beggar. They wanted to know where the power had come from or who had given us the ability to do it. So Peter told them it was by the power of Jesus. He also reminded them that they had crucified Jesus, but that God raised him from the dead. The officials commanded us not to preach in the name of Jesus anymore. But Peter was bold and told them we had to continue doing what was right. They decided to release us. We went back to all the believers and we prayed and praised God so much that God moved powerfully and everyone was full of the Holy Spirit. Have the students glue the correct picture in the box next to Acts 4—believers praised God.



3rd and 4th Grades

The Church Grows

In the early church, everyone shared everything. There were no needy people among us. Sometimes people even sold their property or houses and gave the money to the church to help take care of the needs in the church. I'll bet you still do that today. One day a couple by the name of Ananias and Sapphira decided to sell some property and give the money to the church. The only problem was that they planned to keep some of the money and then lie about it. Ananias took the money to Peter. Peter knew about his plan and asked Ananias why he and his wife had lied about the money. Peter knew that God was upset about their sin. He said they could have kept whatever part of the money they wanted—even the whole thing!—but to lie to the Holy Spirit was a sin. “When Ananias heard this, he fell down and died.” (Acts 5:5) Later, his wife Sapphira came and told the same lie that her husband had told. When Peter confronted her about her sin, she too fell down and died. After that, the whole church was afraid because of these things. Have the students glue the correct picture in the box next to Acts 5—shared possessions.

We continued to preach and do miracles. People from towns around Jerusalem were bringing their sick family and friends to be healed. More and more people were believing and getting baptized. The church was growing bigger every day. The high priest and other religious leaders of the Jewish religion were jealous. We were arrested again and put into jail. During the night an angel of the Lord came and opened the doors of the prison and said, “Go stand in the temple courts and tell the people the full message of this new life.” And we did. Have the students glue the correct picture in the box next to Acts 5—their number increased.

The next day the officials looked for us in the jail but we were gone. They found us at the temple preaching, so they brought us before officials again. This time they were so upset they wanted to kill us. But an older man named Gamaliel stood up and told the officials to leave us alone, so they had us flogged—or severely punished—instead. The rulers told us not to preach anymore and released us. We rejoiced that we were worthy of suffering for the name of Jesus. Of course, we never stopped teaching and proclaiming the good news that Jesus is the Christ. Have the students glue the correct picture in the box next to Acts 5—persecution and preaching.

A Growing Church

Ask the students to look at their pages and name two things the disciples did to help the church grow. (Answers should include: prayed; preached the word; praised God; continued preaching even though they were persecuted; shared their possessions; met together every day.)

Sharing with Others

Ask the students what their favorite part of this story is and ask them to share it with their parents or a friend this week. Close with a prayer for the church today to continue growing as it did in the Bible.

Teacher Tips

- Invite a brother who has experience in theater or drama to come and present this Bible Story in costume. If possible, tape the presentation on video.
- Practice telling this story with excitement and enthusiasm. Know it well enough so that you can look at the students as you tell the story.
- Make sure the students understand that Luke was the writer of Acts and John was a witness of the things he wrote about.



3rd and 4th Grades

The Church Grows

First Century Film

The students will create a film illustrating the events from Acts 2:46-47.

Materials

For each student:

- 1 piece of construction paper, 9" x 12"
- scissors
- glue stick
- crayons, colored pencils and markers

For the teacher:

- ruler
- scissors
- utility knife
- crayons, colored pencils and markers

Reproducible Pages:

- Page C, 1 copy for each student

Preparation

1. Cut out the text boxes, filmstrips and the columns from the copies of Reproducible Page C.
2. Prepare a sheet of construction paper for each student as follows:
 - A. Fold the paper in half, and then cut it along the fold making two 6" x 9" pieces of paper.
 - B. Fold one of these pieces of paper in half again, making a 4½" x 6" card. See Figure A.
NOTE: Save the other piece of construction paper for the student to use during class.
 - C. Align the card so that the fold is on the top. Measure and mark the center point of the card.
 - D. Make two 2" vertical slits (each ¾") from the center point through the front of the card. See Figure B. Do not cut through the back of the card.
3. Make a sample of the craft to show the students.

Instructions

1. Introduce today's craft: In today's class we are learning about the growth of the early church. Show the students your sample. This is a filmstrip of what life was like for the disciples in the first century church. Read the words written on the front of your sample card and then show the "film" by pulling the filmstrip one frame at a time. Read the words on each frame. Today you will make your own filmstrip to remember what everyday life was like in the church.
2. Distribute the unfolded piece of construction paper, glue sticks, scissors and the filmstrips. Have the students glue their filmstrips to the construction paper and then cut them out.
3. Have the students prepare their "filmstrip cards" as follows:
 - A. Distribute the prepared construction paper, columns and text boxes and crayons.
 - B. Have the students glue each column to the front of their cards, one on either side.
 - C. Have the students glue their text boxes to the front of their cards, one near the top and the other near the bottom, as shown in Figure C. Have the students write their names in the space provided.
 - D. Have the students color the front of their cards.
4. Help the students thread their filmstrips through the slits in their filmstrip cards. See Figure D.

Conclusion

Have the students share one of things that the members of the church of God did every day. End the class with a prayer thanking God for the church.

Teacher Tips

- If the students finish early, have them color their filmstrips.

C

R

A

F

T

The Church Grows

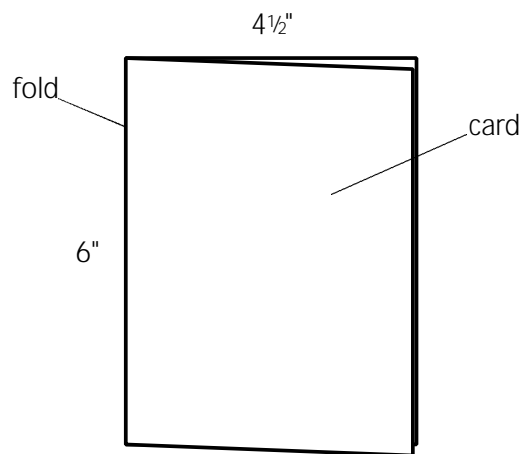

Figure A

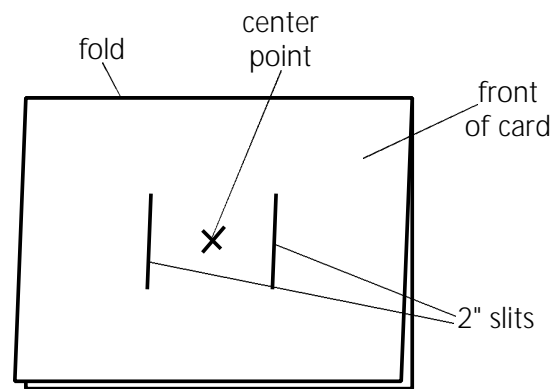

Figure B

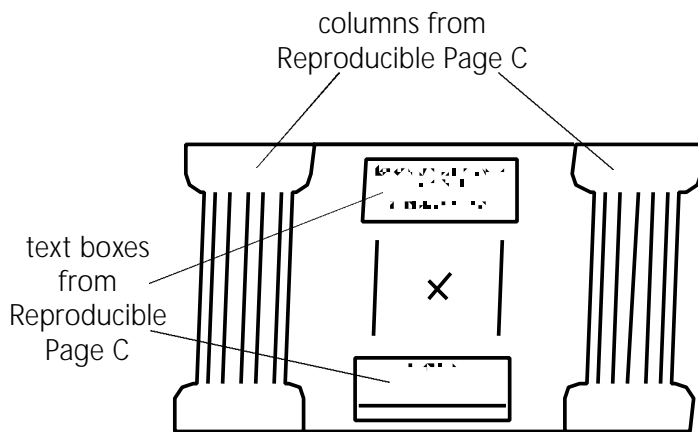

Figure C

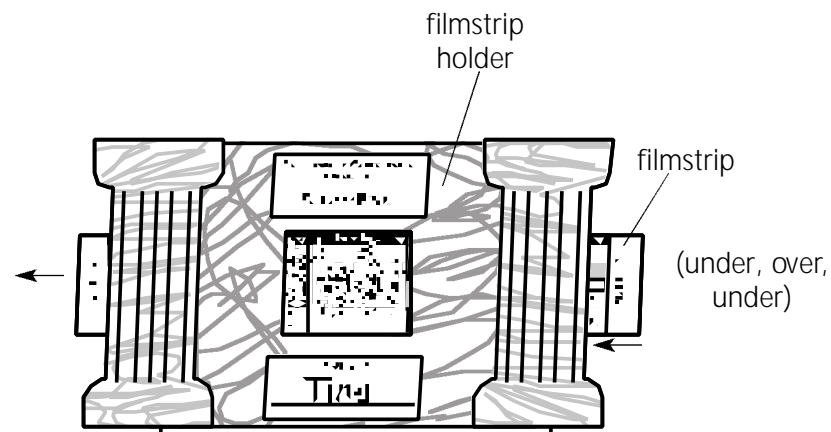

Figure D



3rd and 4th Grades

The Church Grows

Building Blocks

The students will learn and memorize today's Scripture Memory Verse as they "build" it together.

Scripture Memory Verse

And the Lord added to their number daily those who were being saved.
Acts 2:47

Materials

For the teacher:

- 28 index cards, 3" x 5"
- marker

Preparation

On fourteen of the cards, neatly print each of the following words as they appear below, one on each index card. (Keep the other fourteen blank cards for the memory exercise.)

And	the
Lord	added
to	their
number	daily
those	who
were	being
saved.	Acts 2:47

Instructions

1. Introduce today's activity: This week you are learning about the growth of the early church. In today's Scripture Memory Verse you will learn some things the disciples did to help the church grow. The disciples were teaching others, praying, encouraging each other daily, being thankful to God, and living right. God worked among the disciples and many people were saved and added to the church.
2. Show the students the Scripture Memory Verse on the back of this Lesson Card. Say it to them three times as they follow silently. Point to the words as you say them. Ask the students to say the verse together with you three more times.

3. Ask three students to stand and say the verse together with you. Repeat this until all the students have done it.
4. Show the students the cards you prepared. Shuffle and distribute them to the students. Read the verse to them slowly and have them place their cards in order as you say the words. Collect and shuffle the cards and repeat this activity.
5. Collect, shuffle and distribute the cards to the students. Have them place their cards down in the correct order of the verse from memory. Encourage the students to work together and help each other. Repeat this activity.
6. Collect the cards and remove one. Shuffle and distribute them to the students. Have the students place the cards down in their correct order, saying the missing word from memory.
7. Continue each new round by removing one word and replacing it with a blank card until the students can say the entire verse from memory.
8. Ask for volunteers to say the entire verse from memory.

Memory Challenge

If your group wants an extra challenge, prepare cards for both verses 46 and 47 and do this activity. Instead of writing one word on each card, write phrases so that they all fit on fourteen cards.

Conclusion

Ask the students what they think must have been the most exciting part of being in the early church. Close with a prayer thanking God for helping the church grow.

Teacher Tips

- Encourage the students to cooperate and help each other.

The Church Grows

Every day they continued to meet together in the temple courts. They broke bread in their homes and ate together with glad and sincere hearts, praising God and enjoying the favor of all the people.

And the Lord added to their number daily those who were being saved.

Acts 2:46-47



3rd and 4th Grades

Lesson Objectives

- The students will hear the story of how the early church grew.
- The students will name one way disciples help the church.
- The students will name one way they will be more like Jesus.

Lesson Text

Acts 3-5

Scripture Memory Verse

And the Lord added to their number daily those who were being saved.

Acts 2:47

Lesson Plan

Greeting and Registration

Preclass Activity: Daily Growth

Welcome and Singing

Centers:

Life Application: Prepared to Follow

Game: Freeze Frame

Bible Skills: From Town to Town

NOTE: Allow time for a snack.

Daily Growth

The students will review this week's Bible Story as they consider the concept of daily growth.

Materials

For each student:

- glue stick

For the teacher:

- 4 food containers
- 2 large boxes of cereal
- 1 piece of poster board, 22" x 28"
- marker

NOTE: This activity prepares for four groups. Adapt as necessary.

Preparation

Draw a simple outline of a house that fills the entire piece of poster board.

Instructions

1. Greet the students as they arrive. Remind them that this week they learned about how the early church grew daily. If one person were added each day, there would be 365 new members every year.
2. Assign students to work in one of four small groups. Give each group a pile of cereal. Three of the groups will count out 100 pieces of cereal and the fourth group will count out 65. Each group will put their cereal in a container.
3. After they have finished counting their cereal, they can glue it to the poster.

4. Circulate among the students to explain that there are 365 pieces of cereal that stand for the number of people who would be baptized in one year in a church that grows daily. Help the students to see that the early church grew even more than that—and God still wants his church to grow today.

Teacher Tips

- If cereal is not available, have the students draw 365 very small smiling faces on the poster board or use tiny smiling face stickers.
- Cover your workspace with a clean, plastic table cover.



3rd and 4th Grades

Prepared to Follow

The students will review this week's Bible Story as they consider one way they will be like Jesus and the disciples of the early church.

Materials

For the teacher:

- large writing surface

Preparation

1. Read Acts 3-5 to review the events of this week's Bible Story.
2. Make two columns on the large writing surface. Label the left column "Jesus and Disciples" and the right one "Me."
3. Practice leading this activity with enthusiasm.

Reviewing the Bible Story

Open your Bible to Acts 3:19. When Peter and the apostles preached to the people, they told them to repent so that their sins would be forgiven. In Acts 2:38, Peter said, "Repent and be baptized, everyone of you, in the name of Jesus Christ for the forgiveness of your sins," and in Acts 3:19, Peter said, "Repent then and turn to God, so that your sins may be wiped out, that times of refreshing may come from the Lord." What does it mean to repent? (Take a few responses.)

To repent means to change direction—like a U-turn on the road. When we repent, God wants us to turn from doing and thinking bad things and start doing and thinking good and godly things. God does not want us to just change the outside—like our actions and our appearance, but more importantly he wants us to change who we are on the inside—our thoughts and feelings. He does not want us to just say we are sorry for our sin, but he wants us to show we are sorry by changing and doing what we were supposed to do that pleases God. Repentance is not something that a disciple does one time—it is something that a disciple does for his whole life. Repentance is God's way of helping us change and be more like Jesus.

God wants each one of us to be like his Son, Jesus. The disciples in the early church followed Jesus and tried to imitate everything about him. In order to be a disciple we need to repent—or change—and be like Jesus. What are some things you would need to change to be like Jesus? Take a few voluntary responses from the students, but do not force them to respond.

The Church Grows

The Early Church Lesson 2

Life Application

Today, we are going to review things Jesus and the disciples did and name ways we can do similar things today. Write each of these on the large writing surface as you discuss them and the students' responses. Peter healed the beggar.

- What are some ways to show our concern for the poor? (pray for them; give food or clothes; raise money to help them; spend time and be their friends)
- What do you think you might have to change to be like Peter? (selfishness, greed, prejudice)

Peter and John preached and were put in prison.

- What are some ways you can teach others about God? (Invite a friend to church; share with a friend something they have learned about God; tell someone in their family one of the stories from the Bible and why it is important.)
- What do you think you might have to change to be like these disciples? (fear, timidity or shyness, selfishness)

The early Christians shared and sold their possessions.

- What are some ways you can help meet the needs of other disciples? (share or sell some of your belongings; raise money to help others in need; offer to go and serve others)
- What do you think you might have to change to be like these disciples? (selfishness, greed, laziness)

Conclusion

Review some of the ideas that you wrote on the large writing surface. Ask the students to each share one thing that they will try to do this week to be like Jesus and the early disciples. Close with a prayer for God to help the students follow through with their ideas.

Teacher Tips

- Try to plan a time at the beginning of your next class to see how well the students were able to follow through.
- If appropriate, arrange for the students to exchange phone numbers (including yours) and call each other during the week to tell how they did.



3rd and 4th Grades



Freeze Frame

The students will review this week's lesson by re-enacting scenes from Acts 3-5.

Materials

- For the teacher:
- 8 index cards, 3" x 5"
 - hat or small container
 - score pad and pencil



Preparation

On each of the index cards, write one of the scenes from the list below:

- Peter and John healing the beggar at the temple gate.
- The apostles baptizing a lot of people.
- The disciples praying for boldness.
- An angel opening the prison gate for the apostles.
- Ananias bringing money to Peter and lying about it.
- The apostles preaching about Jesus.
- Peter and John being arrested for preaching.
- Disciples bringing their money to help the poor.



Instructions

1. Introduce today's activity: This week you learned about the amazing things that happened when the church first began. We will be playing a game that is like charades. We will be acting out different scenes from this week's Bible Story and then trying to guess what they are.
2. Show the students the cards you prepared and read each one out loud. Fold them up and put them in the hat. Tell them that these are scenes from this week's Bible Story about the early church growth and they will be acting them out without words. Suggest that they give everyone on the team a different role to play. For example, in one scene a student may be "Peter," another "John," and another "the beggar," and the rest can be the crowd who praised God.



3. Divide the students into two teams. Make sure to equally mix students who heard this week's Bible Story with those who did not. Select a team to go first. Explain that both teams can earn points for a correct answer—both the acting team and the guessing team.
4. The first team will pick a card and read it silently. They will have one minute to plan how they will present this scene to the other team without using words. After one minute, the acting team will act out the scene. Once the guessing team thinks they know the answer, they will call out "Freeze Frame" and the acting team will freeze. If the guessing team is correct, they earn two points. If not, the acting team will continue to act out the scene until another student calls out "Freeze Frame." Once again, the acting team must freeze. If the guessing team is correct on the second guess, they receive one point. If not, play is over and no points are given to either team.
5. If the guessing team is correct the first time, then the acting team will earn three points. If the guessing team is correct the second time, then the acting team will earn two points. Use the scoring chart on the back of this Lesson Card to help keep track.
6. Continue alternating until all the cards have been played. Total the points and encourage the students for their participation.

Conclusion

Ask the students what their favorite part of this week's Bible Story was and why. Close with a prayer for the church today to continue to grow like the early church did.

Teacher Tips

- If for some reason your students have not heard the Bible Story, have them act out the scenes using words to better illustrate the scenes.
- If students have difficulty identifying the freeze frame, give them the scripture reference and have them look it up in their Bibles.



3rd and 4th Grades

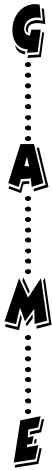

Freeze Frame

Scoring Chart

If the GUESSING team guesses correctly on the first freeze frame, then:

The GUESSING team earns 2 points

The ACTING team earns 3 points

If the GUESSING team guesses correctly on the second freeze frame, then:

The GUESSING team earns 1 point

The ACTING team earns 2 points

From Town to Town

The students will practice finding scripture references and review the growth of the early church.

Materials

For each student:

- pencil
- Reproducible Pages:
- Page D, 1 copy for each student

Preparation

1. Find out and make a list of the first names of people baptized within the past month in your zone or sector and the towns they come from.
2. Complete the activity on your copy of Reproducible Page D.

Instructions

1. Introduce today's activity: In this week's lesson you learned about the growth of the early church. The apostles went from town to town preaching about Jesus. Many people believed, repented and were baptized. The church was growing throughout the known world at that time. In today's activity you will look up scriptures in the book of Acts and write the name of the towns in which people were converted and into which the church spread.
2. Assign each student a partner. Distribute the copies of Reproducible Page D and the pencils. Tell the students to find Acts 19:17. Do this together as an example. Read Acts 19:17-20. Ask the students what the passage is about. (people confessing and repenting) Then ask them where it happened. (Ephesus) Tell the students to write Ephesus in the space provided on their pages.
3. Have the students work at their own pace. When they are all finished, check their answers with your Answer Key.
4. Circulate among the students to offer encouragement and assistance.

The Church Grows

The Early Church

Lesson 2

Then and Now

Help the students to understand that God wants the church to grow today just as it did in the first century. Talk to the students about the people in your zone or sector who have recently been baptized. Read their names. Some of the students may know or be related to the names you are reading. In that case, take time to recognize the children of new disciples and tell them how excited you are for their family.

Conclusion

How does it make you feel to read about so many people who turned to God? What are some things you and your family can do to help the church grow? (Take a few responses.) Close with a prayer for the students to see ways that they can help the church.

Teacher Tips

- With a younger group, you may want to do the entire activity all together instead of in pairs.

From Town to Town
Answer Key

Directions: Locate and read the scripture references below. Write the name of the town or towns into which the church spread.

Scriptures

Towns

Acts 19:17-20

Ephesus

Acts 6:7

Jerusalem

Acts 9:31

Judea, Galilee and Samaria

Acts 9:32-35

Lydda and Sharon

Acts 9:36

Joppa

Acts 11:20-21

Antioch

Acts 14:1

Iconium

Acts 17:1

Thessalonica

Acts 2:5

Jerusalem



3rd and 4th Grades

Core/Preclass
1 copy for each student

The Early Church
Lesson 2

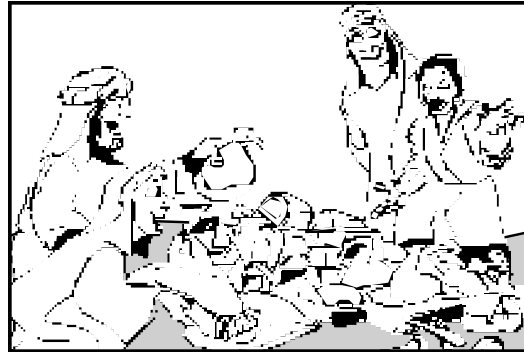

Directions:

1. Color and cut out the pictures.
2. Place the finished pictures in your envelope.
3. Write your name on the envelope.

Name _____

The Church Growth Chart

Core/Bible Story
1 copy for each student

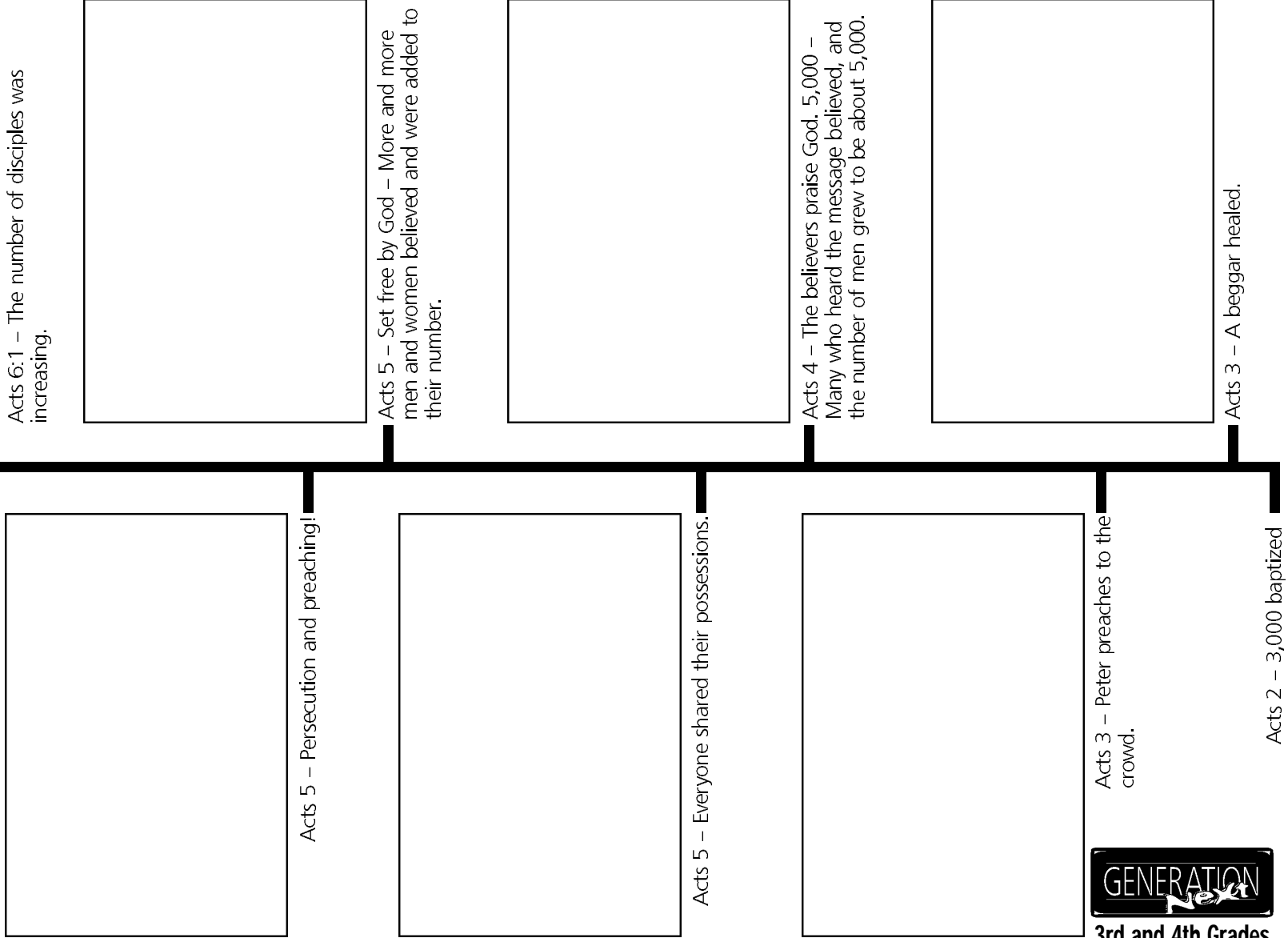

3rd and 4th Grades

filmstrip

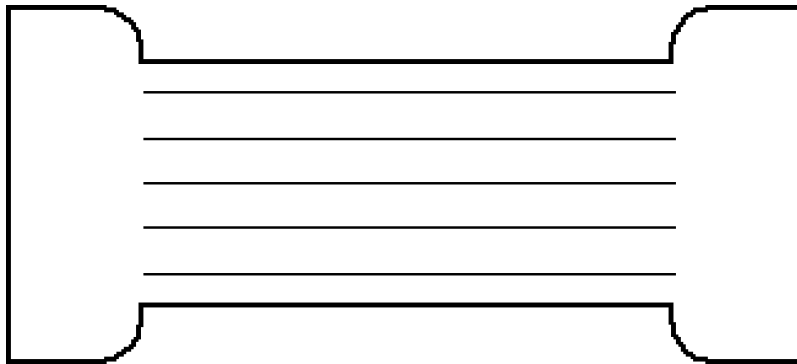
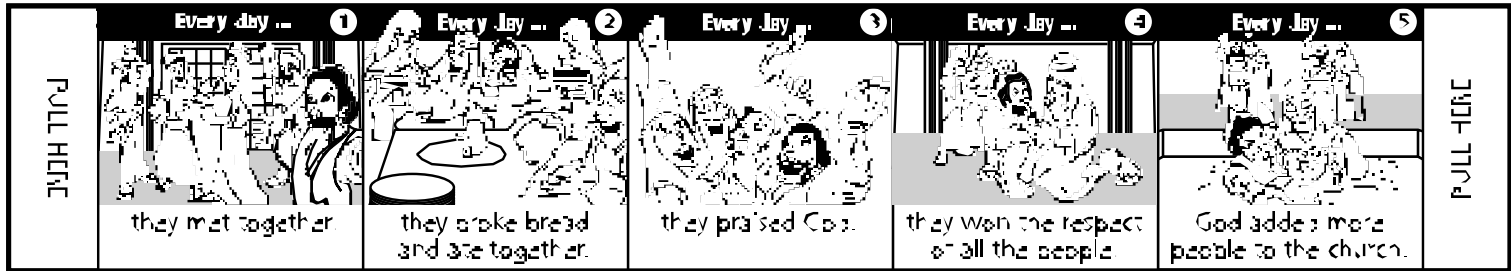

columns

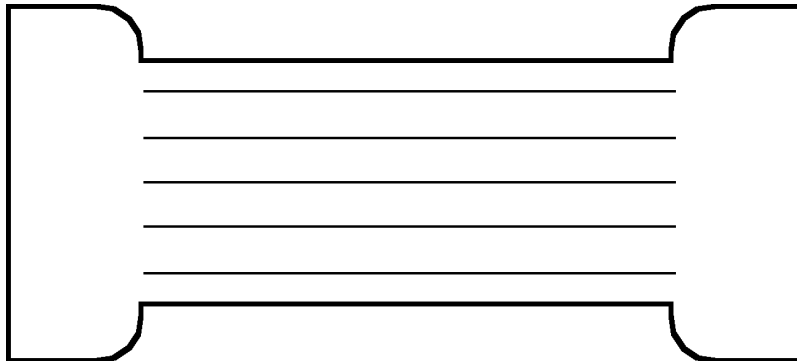

DIRECTED BY:

text boxes

1ST CENTURY CHRISTIANITY
PRESENTS:

EVERYDAY PEOPLE



3rd and 4th Grades

This page intentionally left blank



From Town to Town

Name _____

Directions: Locate and read the scripture references below. Write the name of the town or towns into which the church spread.

Scriptures

Towns

Acts 19:17-20

Ephesus

Acts 6:7

Acts 9:31

Acts 9:32-35

Acts 9:36

Acts 11:20-21

Acts 14:1

Acts 17:1

Acts 2:5



3rd and 4th Grades