

Lesson at a Glance

# Best Friends

## Lesson Objectives

- The children will see that Jesus wants disciples to be best friends by loving each other.
- The children will demonstrate one way to show love for each other.
- The children will name one action that shows people they want to be followers of Jesus.

## Lesson Text

John 13:34-35

## Scripture Memory Verse

"If you love one another, everyone will know that you are my disciples."  
*John 13:35 (NIRV)*

## Lesson Plan

Greeting and Registration

Preclass Activity: Be a Best Friend

Welcome and Singing

Centers:

Bible Story: Love One Another

Craft: Best Friends

Scripture Memory: Hop 'til You Drop

NOTE: Allow time for a snack.

## The Church Lesson 1

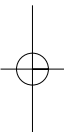

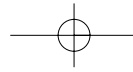

pre  
class

A  
C  
T  
I  
V  
I  
T  
Y

# Best Friends

## Be a Best Friend

The children will preview today's Bible Story as they decorate pencils to give to their friends.

### Materials

For each child:

- 1 unsharpened pencil
- scissors
- red fun foam or red construction paper, 2" x 3"
- white glue
- invisible tape
- decorative items: sequins, glitter, markers, stickers, etc.

For the teacher:

- scissors

Reproducible Pages:

- Page A, 1 copy for every 3 children

### Preparation

1. Prepare the red foam or construction paper for the children. These will be their "flags."
2. Cut out the "sets of hearts" from the copies of Reproducible Page A. Each child will need one set of two hearts.
3. Decorate a sample pencil to show the children.  
NOTE: Do not sharpen the pencils for the children.

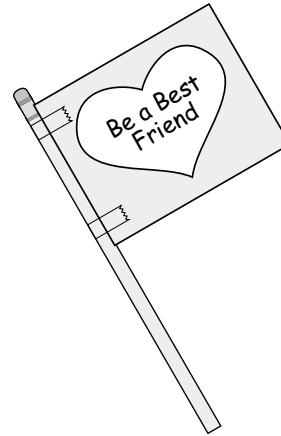

The Church  
Lesson 1

### Instructions

1. Greet the children as they arrive. Tell them that in today's lesson they will learn that Jesus wants his disciples to love each other. Show them your decorated pencils and read to them the words on the flag. *Today, you will be making decorated pencils like this to give to one of your best friends.*
2. Distribute the red flags and sets of hearts you prepared, glue and scissors to the children. Have them cut out their two hearts and glue them onto the red flags, one heart on each side.
3. Distribute the tape and have the children tape their flags onto the eraser end of the pencil, as shown on this page.
4. Distribute the other decorative items and have the children further decorate their flags.
5. As the children work, circulate among them and ask them questions about their best friendships. *Who are some of your best friends? What do you like about them? How does your best friend treat you? To whom will you give this pencil?* You may need to redirect a child's choice if several children have picked the same person.

### Teacher Tips

- To avoid hurt feelings, collect the decorated pencils and have the children give them to one of their "best friends" after being dismissed from class.



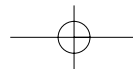

# B Best Friends

## S

## Love One Another

The children will learn and role play the ways that Jesus showed his love.

## I

### Materials

For the teacher:

- 2 pieces of red construction paper, 9" x 12"
- scissors
- marker
- 1 paint stick, approximately 14"
- tape
- small jar or cup
- 1 package of heart-shaped candies

Reproducible Pages:

- Page B, 1 copy for the teacher

## B

## O

### Preparation

1. Cut two large, identical hearts from the red construction paper.
2. On one construction paper heart, write: A new command—Love each other.
3. Cut out the heart from your copy of Reproducible Page B and glue it onto the other construction paper heart.
4. Tape the first construction paper heart to the top of the paint stick.
5. Tape the other heart back-to-back on the other side of the paint stick.

## L

## R

## E

## Y

### Introducing the Bible Story

Open your Bible to John 13:34-35. Tell the children that today's Bible story comes from the book of John. *The book of John was written by one of Jesus' very best friends. Do you have a best friend?* Tell the children that in today's story they will learn about how to be a best friend like Jesus was to John and his other disciples.

### Presenting the Bible Story

Tell the children the Bible Story as follows: *One night Jesus was spending time with his disciples. He told them that he wouldn't be with them much longer. He wanted to tell them something important. Jesus told them that he was giving them a new command. A*

*command is something that someone has to obey. Do you know what he commanded them to do? (Take a few responses.) Jesus commanded them to love each other. Hold up the stick with the "A new command..." side showing. Jesus said, "As I have loved you, so you must love one another" (John 13:35).*

*Jesus loves people very much and he wants all of his followers to love people as much as he does. Jesus told his disciples that people would know they were his followers because of how they loved each other. Jesus' disciples were best friends with each other and with Jesus. That is how Jesus wants his followers to be today—to be best friends that love each other very much.*

Give each child a heart candy to hold and tell them to hold on to it and not to eat it. *Isn't it great to have best friends that love us? Let's think about what kind of a friend Jesus would be to people. Show the other side of the heart you are holding. Read and explain the first way to love like Jesus. Choose a child to act it out.*

NOTE: When discussing kindness, define it as something that helps or builds someone up. It should not be confused with politeness or flattery. For example: kindness would be, "Let me carry that for you," or "I like the way you picked up her book when it fell."

After the child finishes, have the child put the candy heart in the jar. Continue until each child has participated and each loving action has been taught. You can do each action more than once if necessary.

### Share and Tell

*Jesus shows us how to love others by being a best friend. God wants his church to love each other like Jesus would. Who will you show your love to this week? You can show love to your friends by greeting them warmly, saying kind things to them, forgiving them, doing helpful things for them, spending time with them, and telling them about Jesus. Close with a prayer thanking God for giving us Jesus who shows us how to love others.*

### Teacher Tips

- **IMPORTANT:** Be sure that none of the children have allergies to any of the snacks you may serve during this activity. Ask the parents at registration if their child has any food intolerance or food allergies.
- Instead of heart candy, cut out hearts from construction paper.



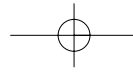

# Best Friends

B  
S  
I  
T  
B  
O  
L  
R  
E  
Y

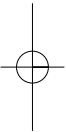
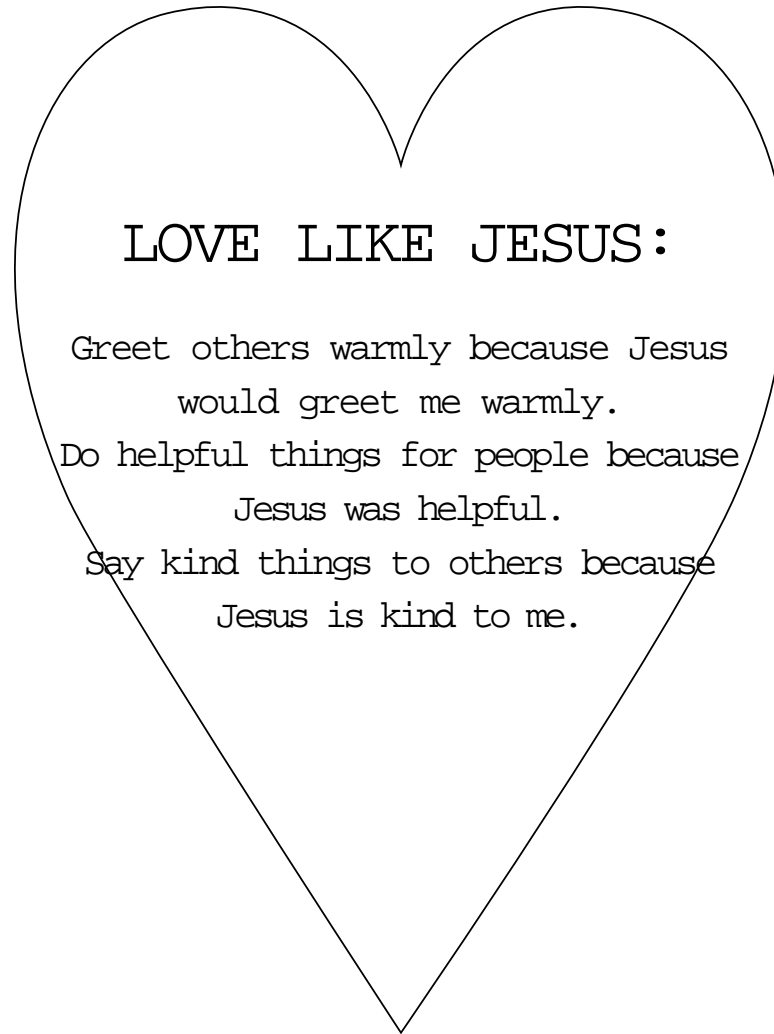

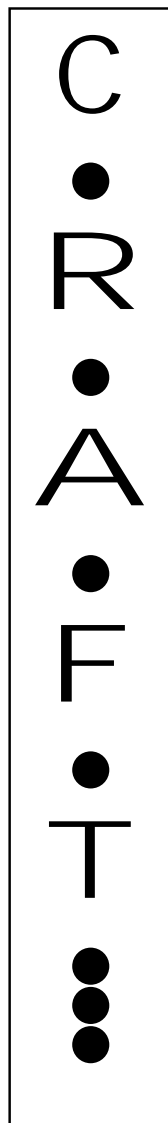
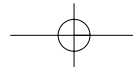

# Best Friends

## Best Friends

The children will make a craft to remind them of Jesus' command to love each other.

### Materials

For each child:

- crayons
- 1 spring-loaded clothespin
- 1 magnetic strip, 2" x 1"
- glue stick

For the teacher:

- scissors

Reproducible Pages:

- Page C, 1 copy for every 4 children

### Preparation

1. Cut out the signs from the copies of Reproducible Page C. Each child will need only one sign.
2. Make a sample craft.

### Instructions

1. Introduce today's activity: *In your lesson today, you are learning that Jesus gave a new command to his disciples: Love one another. He said, "As I have loved you, so you must love one another. All people will know that you are my disciples, if you love each other."* Show the children your sample. Explain that this magnet will remind them of Jesus' command.
2. *Jesus wants us to love one another. What are some ways we can love each other? (Take responses.) We can talk to others kindly like Jesus did. We can give them hugs and make them feel special like Jesus did. We can do helpful things for them like Jesus did. We can spend time with them like Jesus did. That is how Jesus showed his love to his friends.*
3. Distribute the signs that you prepared, crayons, clothespins and glue sticks. Tell the children to color and decorate the signs. Then have them glue their signs to one side of the clothespins, as shown in Figure A.

## The Church Lesson 1

4. Distribute the magnetic strips. Help the children glue their magnets to the opposite side of the clothespin, as shown in Figure B.
5. Make sure the children write their names on their crafts.

### Conclusion

Ask the children to each say one way that they can show love for another child in the class. Encourage them to put their magnets on their refrigerators at home as a reminder of Jesus' command. Close with a prayer asking God to help us all show our love to each other.

### Teacher Tips

- For a sturdier craft, make sure that the signs are reproduced or mounted on heavy paper or cardboard.



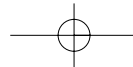

C  
•  
R  
•  
A  
•  
F  
•  
T  
•  
•

# Best Friends

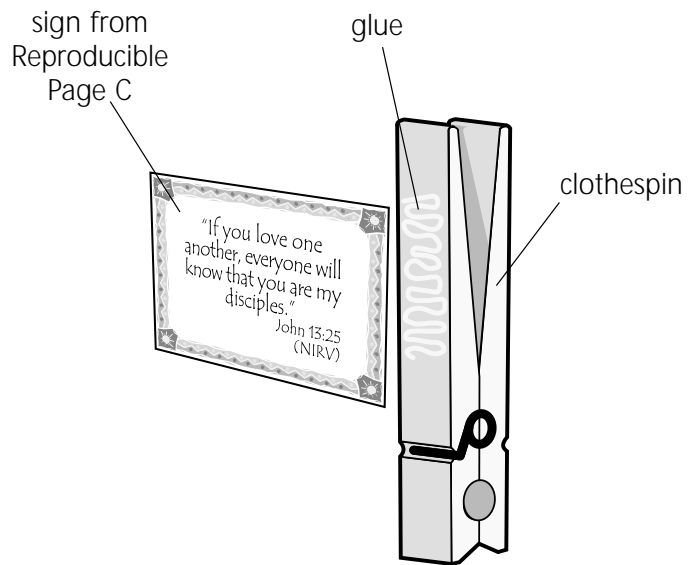

Figure A

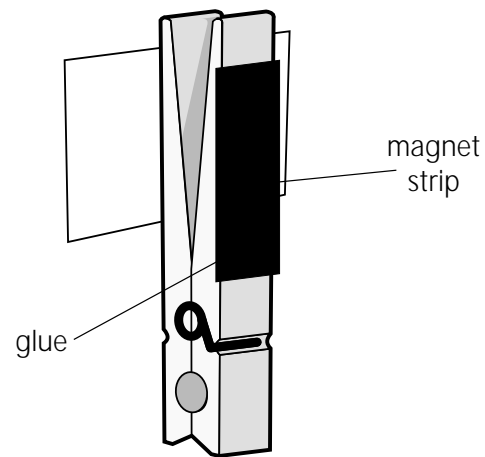
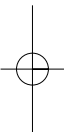
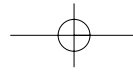

Figure B





# SCRIPTURE MEMORY

## Best Friends

### Hop 'til You Drop

The child will learn and memorize this week's Scripture Memory Verse as they participate in a hopping game.

#### Scripture Memory Verse

"If you love one another, everyone will know that you are my disciples."  
*John 13:35 (NIRV)*

#### Materials

No additional materials are needed.

#### Preparation

Memorize the Scripture Memory Verse.

#### Instructions

1. Open your Bible to John 13:35. Introduce today's activity: *Today we are learning how Jesus wants his followers—or disciples—to love each other and be best friends. What are some ways that you can show love to each other in the church? (Take responses.) Do you know how people can know that we are followers of Jesus? By the way we love each other. That is what our Scripture Memory Verse teaches us.* Open your Bible to John 13:35.
2. Show the children the verse on the back of this Lesson Card and say it to them three times while they follow along. Point to the words as you say them. Ask the children to say the verse together with you three more times.
3. Have the children stand in a circle. Tell them to say the verse together while hopping up and down on two feet. Have the children say the verse together while hopping on one foot and then again while hopping on the other foot.
4. Select one child to hop on one foot across the circle to another child, saying the verse as he goes. When he reaches the child across the circle, have that child return hopping on one foot while saying the verse. Encourage all the children in the circle to help each other remember the verse. Continue until all children have had a turn crossing the circle.

The Church  
Lesson 1

#### Conclusion

Close with a prayer asking God to help us to show love to one another so that people can tell that we follow Jesus.

#### Teacher Tips

- Encourage the children to show love to each other as they do this activity. (saying "good job," being kind and helpful, including everyone, etc.)
- If some children having difficulty hopping on one foot, they can hop using both feet.



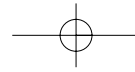

SCR  
IPT  
URE  
MEM  
ORY

## Best Friends

The Church  
Lesson 1

“If you love one another,  
everyone will know that  
you are my disciples.”

John 13:35 (NIRV)





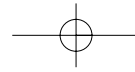

Lesson at a Glance supplement

# Best Friends

The Church  
Lesson 1

## Lesson Objectives

- The children will see that Jesus wants disciples to be best friends by loving each other.
- The children will demonstrate one way to show love for each other.
- The children will name one action that shows people they want to be followers of Jesus.

## Lesson Text

John 13:34-35

## Scripture Memory Verse

"If you love one another, everyone will know that you are my disciples."

*John 13:35 (NIRV)*

## Lesson Plan

Greeting and Registration

Preclass Activity: Hello, Hug and Help

Welcome and Singing

Centers:

Life Application: See Our Love

Game: Beanbag Toss

Bible Skills: Who Am I?

NOTE: Allow time for a snack.

## Hello, Hug and Help

The children will review this week's Bible lesson as they make booklets showing ways to show love for a friend.

### Materials

*For each child:*

- crayons, markers

*For the teacher:*

- scissors
- stapler

*Reproducible Pages:*

- Page D, 1 copy for each child

### Preparation

1. Cut out the booklet pages from the copies of Reproducible Page D for the children.
2. Prepare a sample booklet to show the children.

### Instructions

1. Greet the children as they arrive. Remind them that this week's Bible lesson is about Jesus teaching his disciples to love each other.
2. Show the children your sample booklet and read the words on each page. Explain that they will be making their own booklets to help them remember how to show others their love.
3. Distribute the booklet pages you prepared and the crayons. Have the children color the pictures and the words. Make sure they write their names in the space provided.
4. Circulate among the children to staple their pages together, forming their booklets.

### Teacher Tips

- Encourage the children to greet each other warmly as they arrive.

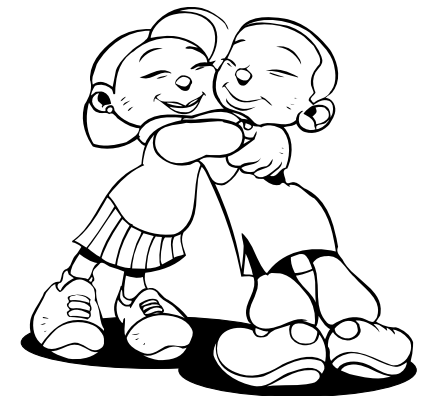

1st and 2nd Grades

SEEDS OF FAITH

pre class

ACTIVITY

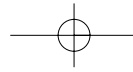

supplement

# LIFE APPLICATION

## See Our Love

The children will review this week's Bible Story as they listen to scenarios and determine which ones describe followers—or disciples—of Jesus.

### Materials

For the teacher:

- large writing surface

Reproducible Pages:

- Page E, 1 copy for the teacher

### Preparation

Practice reading the scenarios with expression.

### Reviewing the Bible Story

Open your Bible to the book of John and say, *In our Bible story this week, we learned that Jesus gave his disciples a new command. Who can tell me what that command was? (love each other as he loved them) Jesus wanted his disciples to love each other and be best friends to each other. He told his disciples that people would be able to tell that they were his followers by the way they loved each other. We learned about some ways that you can show love to each other like Jesus did. Who can tell me what those ways were? (greet others warmly; say kind things to others because Jesus is kind to me; forgive others because Jesus forgives me; do helpful things for people because Jesus did; invite friends to spend time with me; tell friends about Jesus) Jesus said our love for each other is like a big sign. It proves to people in the world that we are followers of Jesus.*

### Life Application

*Today we are going to listen to two stories about children just like you. As you listen to the stories, put your thumbs up if you think the children in the story are showing that they are followers of Jesus by loving one another. If they are not showing that they are Jesus' followers by their love, then put your thumb down. Demonstrate to the children the thumbs up and thumbs down signs.*

# Best Friends

The Church  
Lesson 1

Read the scenarios from your copy of Reproducible E to the children. After each scenario, ask them the following questions:

- *Did the characters in the story show love for each other? (thumbs up or thumbs down)*
- *Do you think the children's actions show that they are followers of Jesus? (thumbs up or thumbs down)*

### Conclusion

Close with a prayer for the children to love one another.

### Teacher Tips

- As a variation, have the children act out the scenarios.

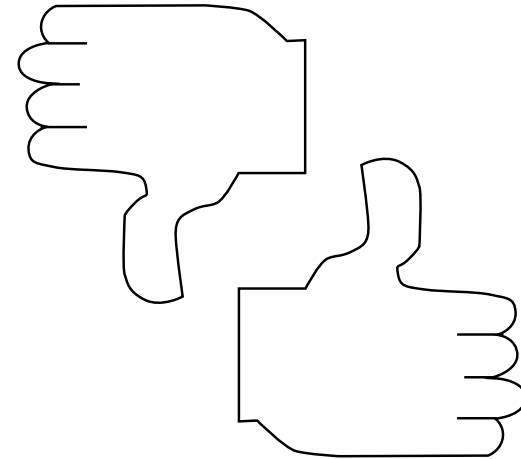

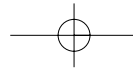

supplement



## Beanbag Toss

The children will play a tossing game as they identify ways to show love to each other.

### Materials

*For the teacher:*

- large box with a lid
- small beanbag
- black marker
- utility knife

### Preparation

1. Cut six separate holes in the lid of the box big enough for the beanbag to go through easily.
2. Practice tossing the beanbag into the box to make sure that the holes are big enough.
3. Using the black marker, number each hole from 1 through 6.
4. Decorate the box.

### Instructions

1. Introduce today's game. *In our Bible story this week, we learned how Jesus taught his disciples to love each other like he loved them. He wants his followers to love each other and be best friends.*
2. Explain to the children that you are going to play a game to help them learn to show love to one another, as Jesus wants them to. Show the children the back of this Lesson Card and read it to them. Explain any words or ideas they may not understand and give some examples of each action.
3. Instruct the children to stand in a line a few feet away from the box. Select one child and tell him to toss the beanbag into any one of the holes in the box lid. Whichever hole it goes in, you will read the corresponding action as numbered on the list. Then ask the child to demonstrate that action to one of the other children in the group. (Be ready to assist and encourage this role-playing.)

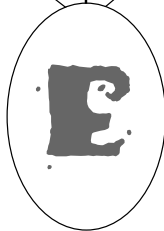

Fall 2

# Best Friends

The Church  
Lesson 1

4. The child to whom he showed love gets the next turn to toss the beanbag. Encourage the new child to try to toss it into a different hole.
5. Continue until all the children have had a turn.

### Conclusion

Ask the children to say which way they most like to show love (e.g., giving hugs, high fives, offering help, etc.) Which way did they most like to be shown love? Close with a prayer asking God to help the children to show love to each other every day.

### Teacher Tips

- Encourage the children to help each other when a child has difficulty getting the beanbag in the holes.
- A large appliance box would work best for this game.
- A coin or small ball may be substituted for the beanbag.

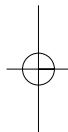

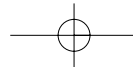

supplement

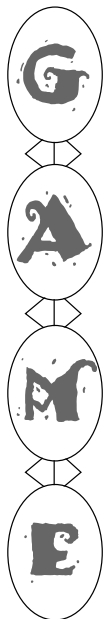

# Best Friends

The Church  
Lesson 1

## LOVE LIKE JESUS



- 1) Greet others warmly.
- 2) Say kind things to others.
- 3) Forgive others.
- 4) Do helpful things for people.
- 5) Invite friends to spend time with me.
- 6) Tell friends about Jesus.

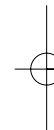
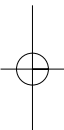

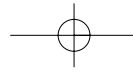

supplement



Fall 2

## Who Am I?

Using clues, the children will identify characters from the Old and New Testaments.

### Materials

*For the teacher:*

- 2 rolls of pennies
- 2 paper cups

### Preparation

Review the list of Bible characters and the clues on the back of this Lesson Card.

### Instructions

1. Introduce today's activity: *Today we will play a game that will give you each a chance to remember some of the people you have been learning about in Bible class.* Divide the group into two teams. Explain that each team can earn pennies for correct answers. These pennies will then be donated to the poor.
2. Read a clue from the back of this Lesson Card to the first team.
3. Instruct the children to discuss the answer among themselves before giving their final answer. If a team gives the correct answer on the first clue, place three pennies in the cup.
4. If a team gets the correct answer on the second clue, place two pennies in the cup.
5. If a team gets the correct answer on the third clue, place one penny in the cup.
6. When a team cannot answer the clue, play passes to the other team. The other team receives one penny if they answer correctly.
7. Play continues with the other team.
8. When all the clues have been read, the team with the most pennies wins. Collect the pennies and tell the children that the money will be donated to help the poor. Explain that this is another way to show love for other people.

# Best Friends

The Church  
Lesson 1

### Conclusion

Review with the children the ways that they showed love during this activity: they worked together to get the answer; they cheered each other on; they spoke kindly to each other; they gave money to the poor, etc. Close with a prayer for the children to really be best friends.

### Teacher Tips

- Praise the children who are being good and doing the right thing without being told.

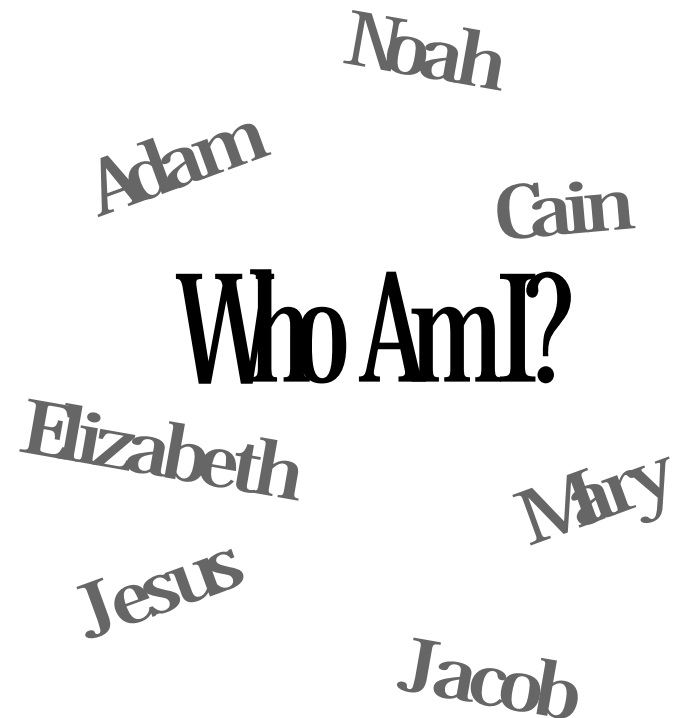

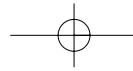

supplement



# Best Friends

## Who Am I?

The Church  
Lesson 1

### Adam

1. I named the animals.
2. God made me from dust.
3. I was the first man.

### Eve

1. I tried to hide from God.
2. I was the first person to sin.
3. I was made from my husband.

### Cain

1. I brought some of the fruits of the soil to the Lord, but my sacrifice was not acceptable.
2. I got very angry at my brother because I was jealous of him.
3. I killed my brother Abel.

### Serpent (Satan)

1. I was more crafty than the other animals in the garden.
2. I lied to Eve in the garden.
3. I tempted Adam and Eve in the garden.

### Noah

1. God used me to save my family and the animals.
2. I saw rain for forty days and nights.
3. With God's help I built an ark.

### Abraham

1. God promised to make me into a great nation.
2. God used my son to test how much I trusted God.
3. My son Isaac was born when I was 100 years old.

### Jacob

1. My brother sold his birthright to me for a bowl of stew.
2. I had twelve sons.
3. I gave my son Joseph a coat of many colors.

### Joseph

1. God was with me in prison.
2. God helped me understand dreams.
3. My father made me a special coat.

### Jesus

1. John the baptist baptized me in the Jordan River.
2. I am called the Son of God.
3. My purpose is to save the world.

### John the Baptist

1. My mom was Elizabeth and my dad was Zechariah.
2. I lived in the wilderness, calling people to repent and be baptized.
3. Herod arrested me and cut off my head.

### Mary

1. An angel told me I would have a son.
2. I married a man named Joseph.
3. I put my baby in a stable.

### Zaccheus

1. I was a chief tax collector.
2. I wanted to see Jesus but I was very short.
3. I climbed up a sycamore fig tree to see Jesus.

### Matthew

1. People called me Levi.
2. Jesus found me sitting in my tax collection booth.
3. Jesus came to my home for dinner along with "sinners" and other tax collectors.

### Elizabeth

1. I was Mary's cousin.
2. I was old when I had my son.
3. I was the mother of John the Baptist.

### God





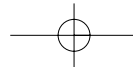

1. I called my son Immanuel.
2. Nothing is impossible with me.
3. I loved the people in the world so much that I gave my only Son to die on a cross for them.





**Core/Preclass**  
1 copy for every 3 children

R  
E  
P  
R  
O  
D  
U  
C  
I  
B  
L  
E  
PAGE  
A

 <p>Be a Best Friend</p>	 <p>Be a Best Friend</p>	 <p>Be a Best Friend</p>
 <p>Love One Another</p>	 <p>Love One Another</p>	 <p>Love One Another</p>

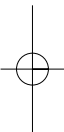

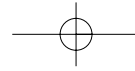

**Core/Bible Story**  
1 copy for the teacher

The Church  
**Lesson 1**

R  
E  
P  
R  
O  
D  
U  
C  
I  
B  
L  
E  
P  
A  
G  
E  
B

PAGE

B

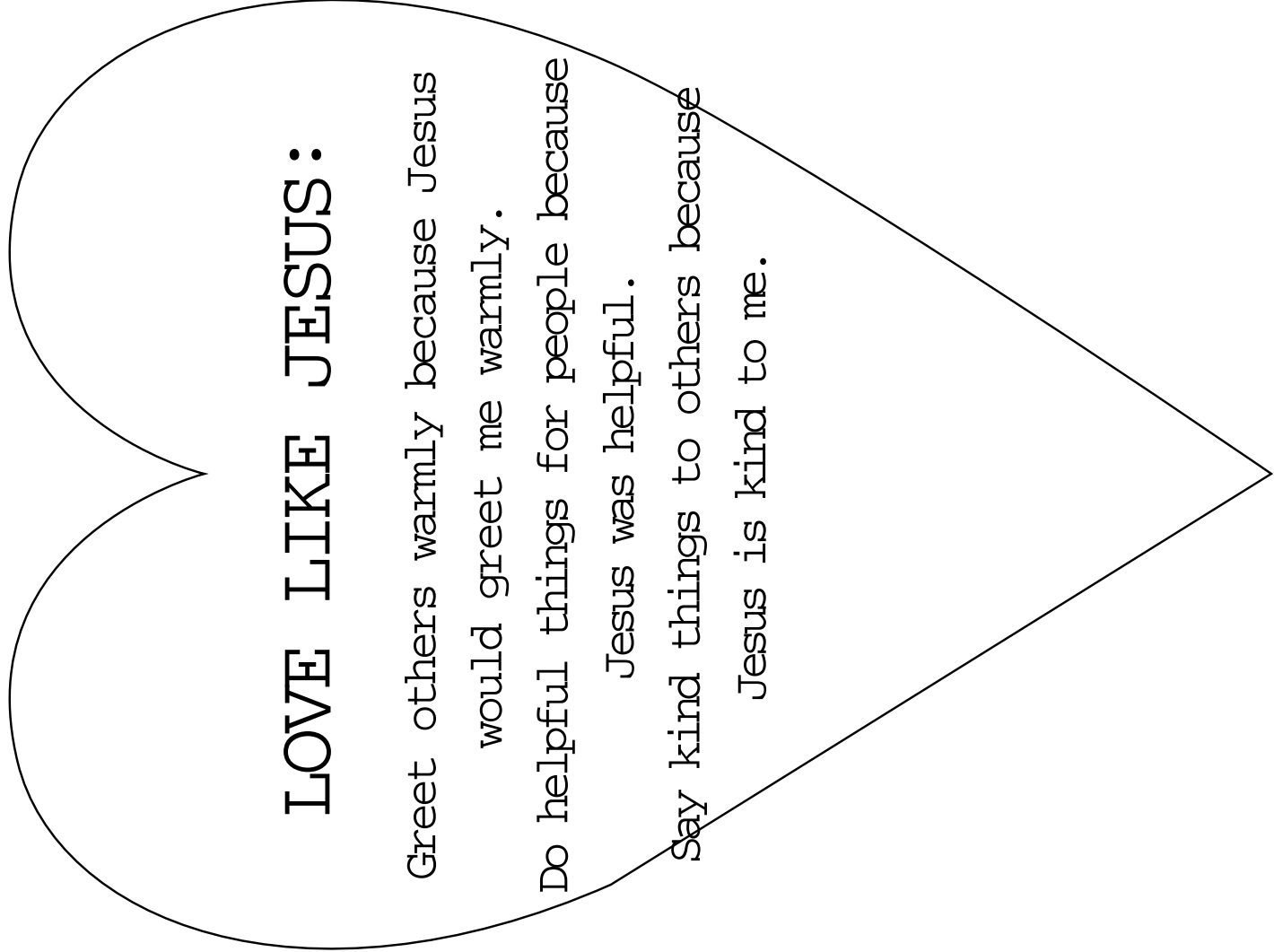

**LOVE LIKE JESUS:**

Greet others warmly because Jesus would greet me warmly.

Do helpful things for people because Jesus was helpful.

Say kind things to others because

Jesus is kind to me.

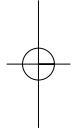



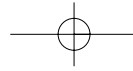

### Core/Craft

1 copy for every 4 children (Optional - heavy paper)

The Church  
**Lesson 1**

R  
E  
P  
R  
O  
D  
U  
C  
I  
B  
L  
E  
P  
A  
G  
E  
C

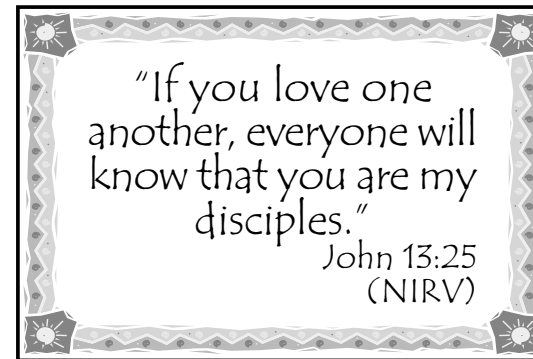
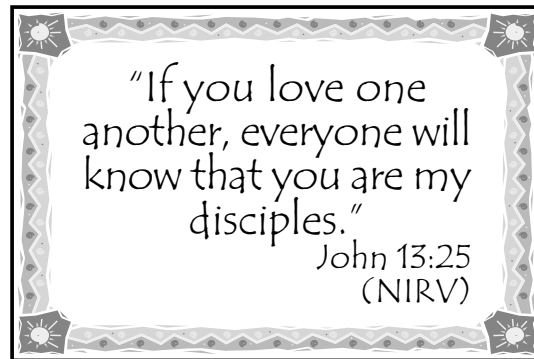
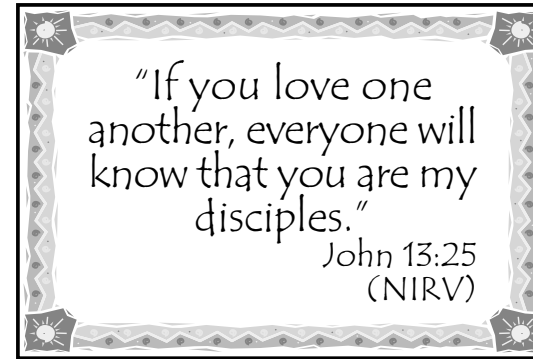
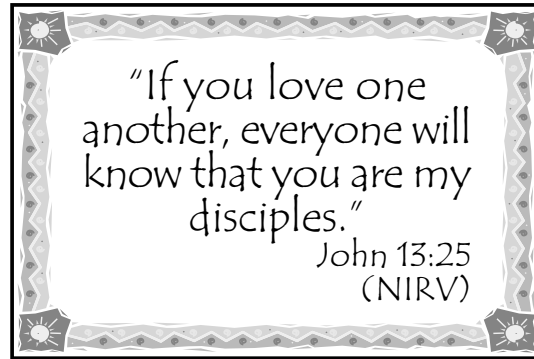

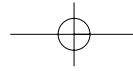

The Church  
**Lesson 1**

---

This page intentionally left blank

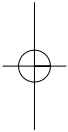

Fall 2

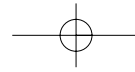

Supplement/Preclass  
1 copy for each child

R  
E  
P  
R  
O  
D  
U  
C  
I  
B  
L  
E  
P  
A  
G  
E  
D

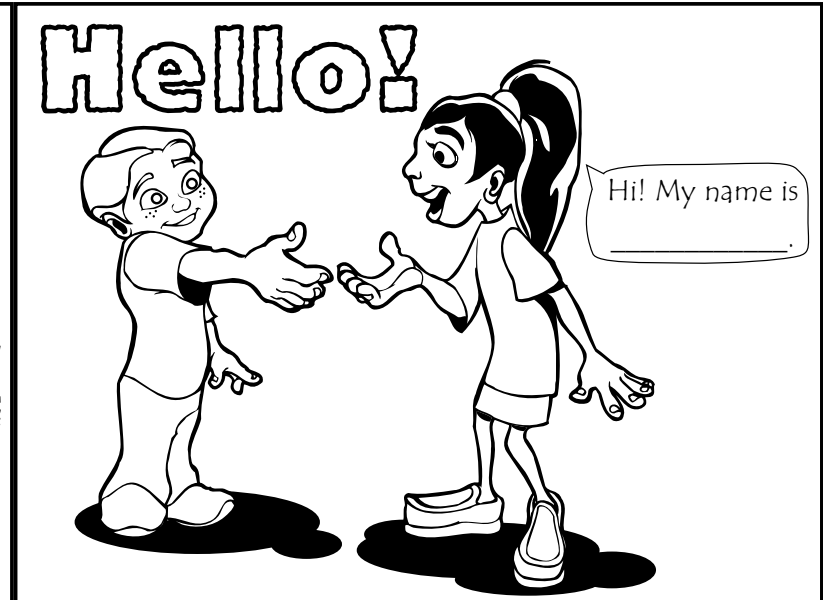

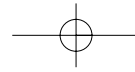

**Supplement/Life Application**  
1 copy for the teacher

**See Our Love**

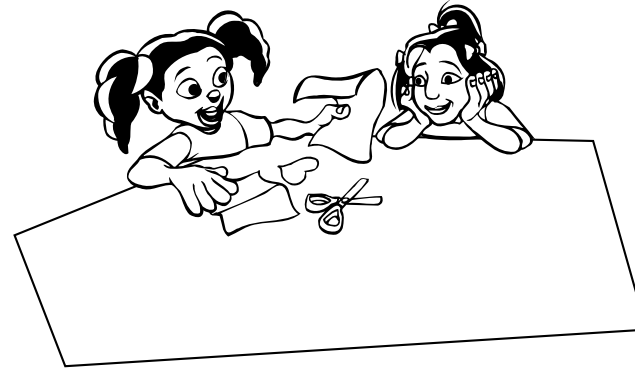

**Scenario # 1**

**Scenario #2**

The first and second grade Bible class is very happy today. They have two new visitors in their class. Sue and Ashley have never been to a church before. They like the Bible class, especially the singing. After singing, Sue and Ashley join the craft center. Lisa, Beth and Jeff are good friends. They come to Bible class every Sunday with their mom and dad. Lisa, Beth and Jeff are working at the craft center. Sue and Ashley join. The children are talking softly as they do the craft. Suddenly Lisa looks at Beth's drawing and says, "Oh! That's stupid. What is that supposed to be? That doesn't look like a head. It looks like a box." Jeff looks and starts to laugh. Beth begins to cry.

Katie and Leslie are sisters. They are very excited because a friend from school is coming to their house for dinner. Their friend's name is Jennifer. Katie and Leslie's mother and father have invited Jennifer's family to dinner. Both families met at the school play. Katie and Leslie's mom and dad are disciples. They are hoping to ask Jennifer's mom and dad to come to church this Sunday. Jennifer finally arrives. The girls go to their room to play. Katie and Leslie share a room. They helped each other clean up their room and arrange all the books and stuffed animals on the shelves. The girls decide to play house. Katie and Leslie share their dolls and toys with Jennifer. Katie gives the best doll to Leslie, while she plays with the broken doll. Soon mother calls the girls to dinner. During the meal, Leslie picks up a fork that Katie dropped. After the dinner, both Katie and Leslie help their mother clear the table.

R  
E  
P  
R  
O  
D  
U  
C  
I  
B  
L  
E  
P  
A  
G  
E

