

HE IS GOD

LESSON TEXT

John 1:1-18

LESSON OBJECTIVES

- Using John 1:1 and John 1:14, the students will be able to state that Jesus is God.
- The students will consider that Jesus is the greatest super hero.
- The students will choose one way to show respect for Jesus this week.

MATERIALS NEEDED

For each student:

- pen or pencil

For the teacher:

- drawing supplies (pencils, construction paper, colored markers, etc.)
- for optional second preclass activity see materials list on Reproducible Page A.
- 1 copy of "Good News from the Kingdom"
- globe or map of the world
- "John the Baptist" (choose someone to play the part)
- a small basket
- dried dates, honey, raisins

Reproducible Pages:

- Page A, 1 copy for the teacher (optional second preclass activity)
- Page B, 1 copy for "John the Baptist"
- Page C, 1 copy for "John the Baptist"
- Page D, 1 copy for the teacher
- Page E, 1 copy for each student
- Page F, 1 copy for each student

LESSON PLAN

Getting Ready

- Faithful Instruction
 - Teacher Focus
 - Teacher Tips
- Preclass Activity: #1 Draw a Super Hero
#2 Tornado in a Bottle
- Starting Up
 - Welcome and Singing
 - Opening Prayer
 - Victories
 - Good News from the Kingdom

Getting into God's Word

- Scripture Study
- Activity: Visit from "John the Baptist"

Getting It to Others

- Scripture Memory: John 1:1
- Activity: Respect Activity Sheet
- Weekly Challenge and Snack Time
- Conclusion

SCRIPTURE MEMORY

In the beginning was the Word, and the Word was with God, and the Word was God.

John 1:1

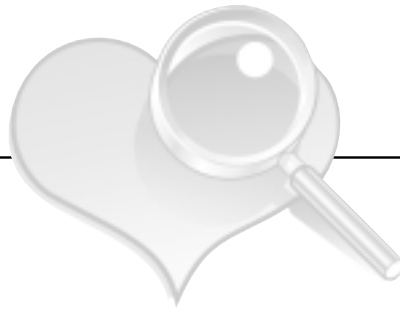

FAITHFUL INSTRUCTION

TEACHER FOCUS

Pray before preparing the lesson. Read and meditate on John 1. Think of (1) how Jesus has shown his power in your life this week and (2) how you have shown Jesus respect this week. Ask yourself, “Why is Jesus my hero? What are some of the heroic qualities of Jesus?”

TEACHER TIPS

As a critical part of the lesson this week, you will be having “John the Baptist” as a special guest in your class. Your selection of the person to play the role is very important. Read the instructions to John the Baptist (Reproducible Page B), and think and pray about someone who could do an excellent job. Make sure he is someone who can really get into the part, and give him plenty of time to prepare.

PRECLASS ACTIVITY

DRAW A SUPER HERO

MATERIALS USED

For the teacher:

- drawing supplies (pencils, construction paper, colored markers, etc.)

PREPARATION

Place materials on a table for the students to make their own super hero (drawing supplies, construction paper, colored markers and glue).

INSTRUCTIONS

1. As the students arrive, direct them to the table to make their own super hero.
2. Ask them to choose a special secret power for their “super hero” and write it on the back of their creation.

CONCLUSION

Ask the students to discuss the powers they gave their super heroes.

OPTIONAL SECOND PRECLASS ACTIVITY

TORNADO IN A BOTTLE

If desired, you can do the activity on Reproducible Page A. Use the demonstration to remind the students of the power of God and Jesus.

CONCLUSION

Talk about how the powers God and Jesus possess are greater than all the powerful things put together.

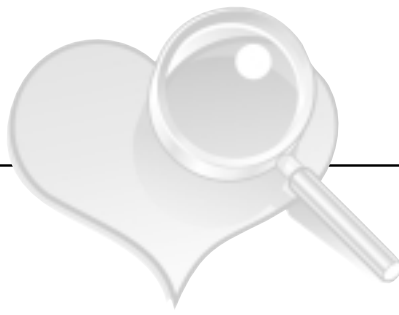

STARTING UP

WELCOME AND SINGING

Call the students together in a circle. Welcome everyone by name, being sure to recognize anyone who is visiting. Let them know how glad you are to see them, and how much you looked forward to being with them. Sing a few great songs.

OPENING PRAYER

Who would like to say a prayer to start today's time together? Let a few students lead the prayer. Encourage the students to mention missing students, special church activities, illnesses, people they want to share Jesus with and to be especially thankful for the chance to be together.

VICTORIES

Take the time to have the students share about the challenge they were given at the end of last week's class. *Did everyone complete his or her challenge? How did it go? What fears did you face as you met the challenge to put the lesson into practice? How did everyone do with having consistent quiet times? Would anyone like to share something they learned in their quiet times?*

Praise and encourage all the students' efforts, especially noting any that show significant growth. Offer help and suggestions so they can have even more victories in the coming week.

GOOD NEWS FROM THE KINGDOM

MATERIALS USED

For the teacher:

- 1 copy of "Good News from the Kingdom"
- globe or map of the world

INSTRUCTIONS

Now let's take a few minutes to share "Good News from the Kingdom." Be excited as you read about what is happening around the world. Have a globe or map ready, pointing out the location as you share.





GETTING INTO GOD'S WORD

SCRIPTURE STUDY

Have the students take out their Bibles and turn to John 1:1-13. Select a volunteer to read the passage.

- *How long has Jesus been with God?* (since the beginning)
- *Where were they together?* (in heaven)
- *Who was the "light" that John the Baptist talked about?* (Jesus)
- *Did people know who Jesus was?* (no)
- *Who made us?* (Jesus)
- *Were people excited to see him?* (no)

Name a famous person, or have the students name some of their real-life heroes, and talk about how excited we would be to see them. *The people in Jesus' time got to meet the person who made them and has ultimate power, and yet, they did not "receive" or accept him. The people who do receive him get to be children of God!* Talk about what it would be like to be the son or daughter of a king on earth and how much more it means to be a child of God.

ACTIVITY

VISIT FROM "JOHN THE BAPTIST"

MATERIALS USED

For the teacher:

- a small basket
- dried dates, honey, raisins

Reproducible Pages:

- Page B, 1 copy for "John the Baptist"
- Page C, 1 copy for "John the Baptist"
- Page D, 1 copy for the teacher

PREPARATION

1. Carefully read the "Getting Ready" section of the lesson plan and the "Instructions for John the Baptist" (Reproducible Page B).
2. Give the person you have chosen a copy of Reproducible Pages B and C. Make sure your John the Baptist knows the answers to the questions and is able to really get into his part and make it fun!
3. Cut a copy of Reproducible Page D (Questions for John the Baptist) along the dotted lines so that each question is separate.
4. Fold questions individually and place in the small basket.
5. Have the dates on a tray with a jar or container of honey in the middle. John will serve them to the group after his presentation.

INSTRUCTIONS

1. Read John 1:15-18 and have a student read verses 19-23. Then have another student read verses 23-28. Talk briefly about these verses, and tell the children you have a very special guest coming to the class today.
2. *We have John the Baptist here today! He is going to tell us what it was like to be around Jesus!* Tell the children you have questions you want them to ask him. Hand out the questions and tell them they can ask their own questions as well.
3. Welcome John into the class and introduce him. Remind the children to remember to raise their hands to ask a question. Ask the printed questions first, and guide the students not to ask silly questions.
4. After John has finished his presentation, tell him to have fun with offering the students "locusts" (dates) and "baby locusts" (raisins) along with "wild honey."





SCRIPTURE MEMORY

In the beginning was the Word, and the Word was with God, and the Word was God.

John 1:1

MATERIALS USED

Reproducible Pages:

- Page E, 1 copy for each student
- Page F, 1 copy for each student

INSTRUCTIONS

1. Pass out a copy of Reproducible Page E (Respect Activity Sheet) to each student.
2. Help the students fill out the bottom portion very specifically: which friend they will call, the phone number or how to get it, which Bible scripture they will read and when (before or after school, before bed, etc.), who they are going to help, how, etc.
3. The challenge is for the students to choose one way to show respect for Jesus this week (as indicated on Respect Activity Sheet, Reproducible Page E).
4. Pass out a copy of Reproducible Page F (memory verse) to each student to take home.

WEEKLY CHALLENGE AND SNACK TIME

If the students brought a snack to eat today, allow them to eat it while you explain to them the challenge for the week.

Remind the students that they have learned today that Jesus is God, that he is the greatest super hero, and, therefore, we should show him the respect he is due. Challenge the students to decide to be an example for others as they show respect for Jesus. Ask them to commit to one way that they will show respect for Jesus this week.

CONCLUSION

End the class with a prayer.

WEEKLY CHALLENGE

Choose one way to show respect for Jesus this week.

HE IS GOD

LESSON TEXT

John 1:18, 6:46, 14:8-11

LESSON OBJECTIVES

- The student will use John 1:18 and John 6:46 to show that Jesus is the only one who has ever seen God.
- The student will identify the truth that Jesus knows God like no one else knows him.
- The student will identify specific ways Jesus is his or her hero.

MATERIALS NEEDED

For each student:

- paper
- pencil

For the teacher:

- pictures of famous people
- pen
- various types of paper: construction, poster board, colored tissue, etc.
- scissors
- glue
- dress-up clothes for hero (6 clothes items for each team)
- package of dried dates
- 2 tube socks
- 2 large baskets
- 1 buzzer or bell
- 2 large cups
- 6 slips of paper
- dress-up outfit for Jesus
- dress-up outfit for Philip
- a small box or basket

LESSON PLAN

Getting Ready

Faithful Instruction
Teacher Focus
Preclass Activity: "A Day with Your Hero"
Starting Up
Welcome and Singing
Opening Prayer
Great News Sharing

Getting into God's Word

Scripture Study: Skit—"Jesus and Philip"
Activity: "Cool Question Cup" Game

Getting It to Others

Scripture Memory: John 1:1
Weekly Challenge and Snack Time
Conclusion

SCRIPTURE MEMORY VERSE

In the beginning was the Word, and the Word was with God, and the Word was God.

John 1:1

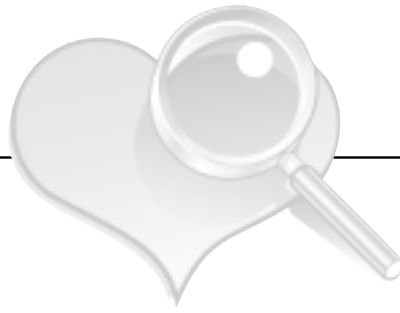

FAITHFUL INSTRUCTION

TEACHER FOCUS

In the previous class, your students discussed modern-day heroes. Students at this age have heroes whose attitudes and lifestyles are not exemplary—and sometimes are even criminal. The students learned that Jesus is the most incredible hero and that he is supremely worthy of our respect. They read John 1:14, which teaches that Jesus is God. John the Baptist visited as a guest speaker and answered questions about what it was like to be a friend and follower of Jesus. This visit was to help the students come to know Jesus in a personal way through someone who had spent time with Jesus. Today's lesson carries through this same idea: that Jesus spent time with God and, thus, is able to help us know God. We have only to pay close attention to what he said!

Review the lesson before class and make sure your heart is worthy of imitation. As the teacher for this class, God has handpicked you to impress upon your students a love and an admiration for Jesus that is greater than they have ever known. In today's lesson you will focus on how Jesus has always been with God and is the only one that has ever seen God.

PRECLASS ACTIVITY

"A DAY WITH YOUR HERO"

MATERIALS USED

For each student:

- paper
- pencil

For the teacher:

- pictures of famous people

INSTRUCTIONS

1. Before class begins, you will need to have several pictures of famous people from sports, movies, television or music on a table along with sheets of paper and pencils. (Make sure the pictures are of people that the students will recognize.)
2. As the students arrive, greet them and direct them to the table where they will look at the pictures.
3. Tell the students: *If you were going to spend a day with your favorite modern-day hero, what would you want to do with him or her? (Write down the schedule of events.) Write down five questions you would want to ask him or her.*
4. Have the students hold on to the questions and the schedule to use later in the class.

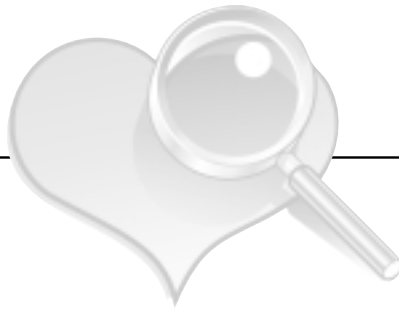

STARTING UP

WELCOME AND SINGING

Call the students together in a circle. Welcome everyone by name, being sure to recognize anyone who is visiting. Let them know how glad you are to see them, and how much you looked forward to being with them. Sing a few great songs.

OPENING PRAYER

- Open with one of the students praying for one to two minutes about being able to know Jesus in order to see God.
- Have one student recite the memory verse for this lesson: John 1:1.
- Have a student briefly review the previous lesson (Core Lesson).

GREAT NEWS SHARING

Allow several minutes for the students to share great news about their lives. This could be about a family member who became a disciple, someone healed from an illness, someone studying the Bible, great grades, etc. Remind the students to be brief, so that as many as possible can share.

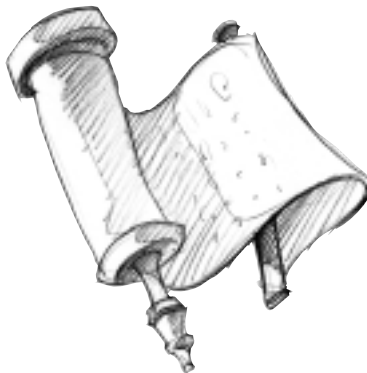



SCRIPTURE STUDY

SKIT: "JESUS AND PHILIP"

MATERIALS USED

For the teacher:

- dress-up outfit for Jesus
- dress-up outfit for Philip
- a small box or basket

PREPARATION

Write out a short hypothetical dialogue between Jesus and Philip showing what the conversation in John 14:8-11 between Jesus and Philip could have been like if Philip had truly understood who Jesus was.

INSTRUCTIONS

- Have two students in your class, or you and a student, dress up and act out the conversation between Jesus and Philip in John 14: 8-11. After the scene has been acted out, ask the students the following questions.
- *What did Philip ask Jesus to do for them?* ("Lord, show us the Father and that will be enough for us.")
- *What was Jesus' response?* ("Don't you know me, Philip, even after I have been among you such a long time? Anyone who has seen me has seen the Father. How can you say, 'Show us the Father?' Don't you believe that I am in the Father and the Father is in me?")
- Have the students look at these two statements: "Show us the Father" and "Don't you believe that I am in the Father and the Father is in me?" *What do you think Jesus is trying to get Philip to understand by asking these questions?* (Jesus was trying to help Philip to understand that he and the Father were the same.)
- *What does Jesus tell Philip and the disciples about God and himself?* ("The words I say to you are not just my own. Rather, it is the Father, living in me who is doing his work. Believe me when I say that I am in the Father and the Father is in me, or at least believe on the evidence of the miracles themselves." Help the students realize that Philip did not understand that Jesus was the only one who has seen God. Philip also did not understand that Jesus and

God were the same. God sent Jesus to Philip so he could see what God was like through Jesus. Read John 6:46 and John 1:18. Discuss what these scriptures mean.)

- *Do you feel Philip was respectful to Jesus? Why or why not?* (No, because he did not respect Jesus for who he really was. Only Jesus had ever seen God and only Jesus was truly worthy to see God. By asking Jesus to show him the Father, Philip did not believe that Jesus was who he said he was.)
- Ask the students to bring out the questions from the preclass activity they wrote. Have some of them share their questions. Talk about how excited they would be if they really did get to spend a day with these people. How much more excited should we be to spend a day with Jesus? Discuss how the conversation between Philip and Jesus would have been different if Philip really understood who Jesus was and that he had such a "tight" relationship with God. Ask two students to act out the hypothetical dialogue with Philip understanding who Jesus was.
- Have the students write three or four sentences on what they learned about Jesus as their true hero from John 14: 8-11. Have the students drop their responses into a box, hat or cup. The teacher can then read all of the responses aloud.

ACTIVITY

"COOL QUESTION CUP" GAME

MATERIALS USED

For the teacher:

- package of dried dates
- dress-up clothes for hero (six clothes items for each team)
- 2 tube socks
- 2 large baskets
- 1 buzzer or bell
- 2 large cups
- 6 slips of paper



PREPARATION

1. Label one of the large cups "Cool Questions Cup" and the other one "Challenge Cup."
2. Challenge Cup: On two separate slips of paper, write each challenge: "Super Hero Race" and "Sock in a Basket." Place the pieces of paper, folded, in the "Challenge Cup."
3. Each challenge will be acted out as follows:
 - **Super Hero Race:** Each team should choose a team member to stand at the other end of the room. The teams will race across the room and dress their member up as a hero as fast as possible using all the items provided. The team to finish first wins. Sound bell or buzzer!
 - **Sock in a Basket:** Make a "ball" out of each sock. Each team chooses a person to attempt to shoot the sock into a basket that is ten feet away, as if shooting a basketball. Each "shooter" should take ten tries, and the one who makes the most baskets wins.
4. After one of the challenge slips is drawn, it is returned to the cup, and can be drawn more times. In each subsequent drawing, the team should choose someone new to be the "super hero" or the "shooter."
5. On four slips of paper write the following topics, one on each slip:
 - Crawling Creatures
 - Flying Objects
 - Human Talents
 - Creative Colors
6. Place the four slips of paper, folded, in the "Cool Question Cup."

INSTRUCTIONS

1. Split the group into two teams and help each team designate a team captain.
2. Teacher draws one of four questions from the "Cool Question Cup."
3. The teacher asks each team to come up with a "cool" question to ask Jesus about that topic. Examples of answers for the four topics, respectively, are (1) Why do dachshunds have such short legs? (2) Why do hummingbirds have such short wings and yet can fly so far? (3) Why are some people able to sing beautifully and others cannot carry a tune? (4) Why did you decide to make the trees green?
4. Call time in 15 seconds. Award ten points to the team that came up with a question. (Both receive points if they came up with a question.)
5. The teacher then draws a challenge from the "Challenge Cup."
6. The team that wins the challenge gets five points.
7. The teacher continues drawing alternately from the two cups until the Cool Question Cup is empty.
8. The team at the end with the most points wins.



SCRIPTURE MEMORY

In the beginning was the Word, and the Word was with God, and the Word was God.

John 1:1

Review the scripture memory that was given during the previous lesson. Practice the verse together with the class, encouraging the students to have the verse completely memorized by the next class.

WEEKLY CHALLENGE AND SNACK TIME

If your students bring a snack, allow them to eat while you explain to them the challenge for the week. (The students were to choose one way to show respect for Jesus this week.)

MATERIALS USED

For each student:

- various types of paper: construction, poster board, colored tissue, etc.

INSTRUCTIONS

1. Provide a table with the items from the above materials list on it.
2. Encourage the students to use the materials to make an artwork that express the power and/or the deity of Jesus to them. After they are finished, ask them to name their artwork and put their own names on it, also.

CONCLUSION

End the class with a prayer.

WEEKLY CHALLENGE

Choose one way to show respect for Jesus this week.

TORNADO IN A BOTTLE

Optional Second Preclass Activity

Use the following demonstration to remind the students of the power of God and Jesus that we see displayed in a tornado.

MATERIALS USED

- pictures of powerful things (volcanoes, electricity, hurricane, etc.)
- 1 empty 2-liter bottle
- 1 2-liter bottle filled with water
- food coloring (or confetti)
- duct tape

INSTRUCTIONS

1. Have the students gather around the table you have set up with pictures of powerful things.
2. Discuss with them the power that is displayed in each of these examples.
3. Ask them to share about powerful things that they may have seen or experienced, and you share about things you have seen or experienced. Especially find out what they know about tornadoes.
4. Do the demonstration below:
Step 1—Fill one of the two-liter bottles with water.
Step 2—Put one to two drops of food coloring (or confetti) in the water (figure A).
Step 3—Place the two open ends of the bottles together and tape with duct tape (figure B).
Step 4—Hold the bottles vertically, with the filled bottle on top.
Step 5—Spin the bottles rapidly in a circular motion (figure C).
Step 6—Hold them in the same vertical position with the empty bottle on the bottom, and watch the tornado appear in the top bottle (figure D)!
5. Make sure that you have been successful in trying the demonstration at home before attempting it for the students.

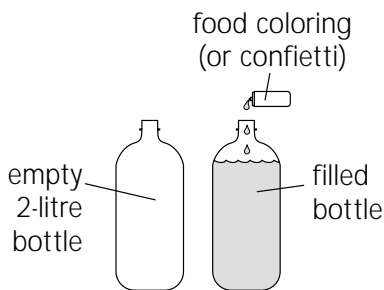

Figure A

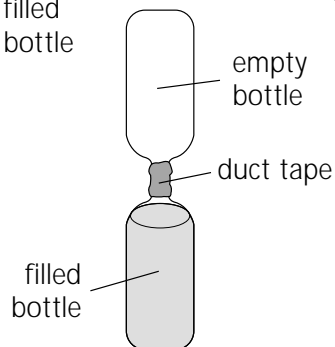

Figure B

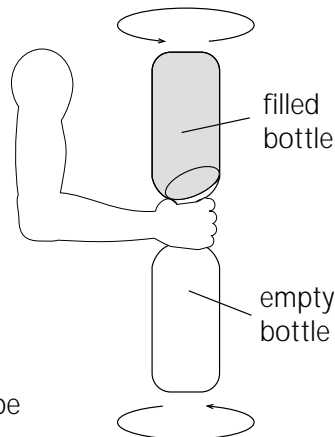

Figure C

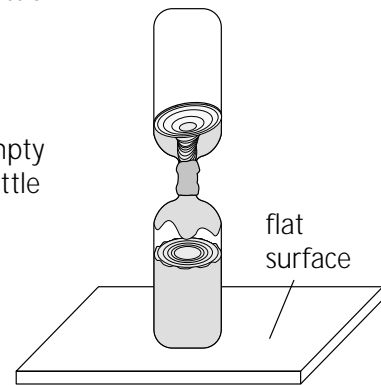

Figure D

INSTRUCTIONS FOR JOHN THE BAPTIST

You have been chosen for a very important role in today's class. Make sure you talk with the teacher and follow any directions he or she gives you. Please read all the questions and answers before class and, if possible, memorize them. To get into the character of John the Baptist, read Matthew 3 and John 1:6-42, 3:22-36.

BEHAVIOR

As you can tell from reading Matthew 3, John the Baptist was a wild character! The wilder you can be, without going overboard, the more fun you will make it for the students and the better they will remember the lesson. Be wild and have fun because for one hour, you *are* John the Baptist!

Some "wild" ideas: bang the staff on things in the room, talk loudly and move around as you talk, get in the face of the student asking the question, offer the "locusts" (dried dates) to the students, comment on the locust's crunchy outside and gooey inside.

CLOTHING SUGGESTIONS

You can choose either clothing style based upon what is available to you.

1st Century John the Baptist:

(see figure A)

- wild hair or wig
- dirt on hands and face
- bed sheet (or large cloth) with neck cut out for robe
- fur coat/cloak
- walking stick/staff
- leather bag
- rope belt
- sandals

20th Century John the Baptist:

(see figure B)

- face paint
- suede/leather jacket
- mountain shoes
- walking stick/staff
- safari hat
- whip

SUPPLIES

Use dried dates as "locusts," raisins as "baby locusts" and honey—(makes the locusts go down better!)



Figure A



Figure B

Core/Getting into God's Word/1 copy for "John the Baptist"

QUESTIONS AND ANSWERS FOR JOHN THE BAPTIST

Q #1: Are you the John who wrote the Book of John in the Bible?

A #1: *No that was the disciple John.*

Q #2: How do you know Jesus?

A #2: *I am his cousin. God sent me to tell people about Jesus.*

Q #3: What was it like being around Jesus?

A #3: *Awesome! He was so powerful and yet so gentle and loving. I couldn't help but respect him. I loved telling people about him.*

Q #4: When was Jesus born?

A #4: *Jesus was with God before the beginning of time. God and Jesus decided that Jesus should come to earth and be human to teach us about God.*

Q #5: Who is more powerful, God or Jesus?

A #5: *They are exactly the same. God gave his Son all the same powers he has. The Bible teaches that the two are one.*

Q #6: How did people treat Jesus?

A #6: *That is what hurt me the most. Some people treated Jesus awful! Then because he didn't fight back, they thought he was weak. They never understood how much he loved them. But the people who did listen and did respect him were very happy. He changed their lives!*

Q #7: What are some of the mean or awful ways they treated Jesus?

A #7: *They called him a liar then told lies about him. They called him names and even said he was from Satan.*

Q #8: Did you ever get really angry with those people that called Jesus names and put him down?

A #8: *Sure, sometimes I even felt like hitting them! But I didn't. Jesus set the example for me. He would just calmly walk away. They wanted him to fight, so they hated it when he wouldn't fight them.*

Q #9: How can we show Jesus respect?

A #9: *Well, by believing he is God's Son and then obeying what he says in the Bible. Can you think of what some of those things are? (Let students answer.) Can you name some things that would show disrespect for Jesus? (Again, let students answer).*

Closing Comment

"I enjoyed being with you! Thanks for letting me come!"

QUESTIONS FOR JOHN THE BAPTIST

Cut along the dotted lines:

.....
Question #1: Are you the John that wrote the Book of John in the Bible?

.....
Question #2: How do you know Jesus?

.....
Question #3: What was it like being around Jesus?

.....
Question #4: When was Jesus born?

.....
Question #5: Who is more powerful, God or Jesus?

.....
Question #6: How did people treat Jesus?

.....
Question #7: What are some of the mean or awful ways they treated Jesus?

.....
Question #8: Did you ever get really angry with those people that called Jesus names and put him down?

.....
Question #9: How can we show respect for Jesus?

Circle one that you will do this week to show Jesus respect.

Read the Bible every day

Eager to obey Jesus

Sing to Jesus, joyfully

Pray to Jesus every day

Eagerly help others

Call a friend in Bible class to see how their day went

Teach a friend or younger brother or sister that Jesus is God and has the greatest power

I will _____ to show Jesus respect.

SCRIPTURE MEMORY VERSE

In the beginning was the Word,
and the Word was with God,
and the Word was God.

JOHN 1:1

WEEKLY CHALLENGE

Choose one way to show respect for Jesus this week.