

# Paul, Timothy and Lydia

**Paul Goes**  
Lesson 2

## Lesson Objectives

- The children will name Paul and Timothy as people who taught others about Jesus.
- The children will say, "Lydia," when asked, "Who invited Paul and Timothy to her home?"
- The children will role-play having someone into their home.

## Bible Story Text

Acts 16:1-5; 13-15

## Bible Truth

Paul obeyed God.  
(Acts 23:1)

## Lesson Plan

Greeting and Registration

Preclass Activity: Preclass Centers

Welcome and Singing

Centers:

Bible Story: Paul Tells Others

Life Application: God's Preachers

Craft: Paul and Timothy Preach

NOTE: Be sure to allow sufficient time for a snack.



# Paul, Timothy and Lydia

## Preclass Centers

As the children arrive, guide them to a preclass center. Have no more than six children at each center.

### Materials

Use the materials previously selected for this unit's preclass centers.

### Preparation

1. Be sure to check the condition of the materials selected for this unit's preclass centers prior to set up. Replace any broken toys, or puzzles with missing pieces as necessary.
2. Set up the centers before the children come into the classroom.
3. Assign a teacher to each center and have the teachers stay in those centers until the singing begins.

### Instructions

Guide the play in each center reinforcing the unit theme.

### Teacher Tips

- **IMPORTANT:** Do not allow any small toys in the classroom. First check all toys for size. You can obtain a "safety cylinder" from a pediatrician. Any object that can fit into the cylinder is too small and could cause a child to choke.
- Be involved in the group play and offer guidance as needed.
- Wear comfortable clothes suitable for sitting on the floor.
- Smile! Be childlike in heart and alert in mind.

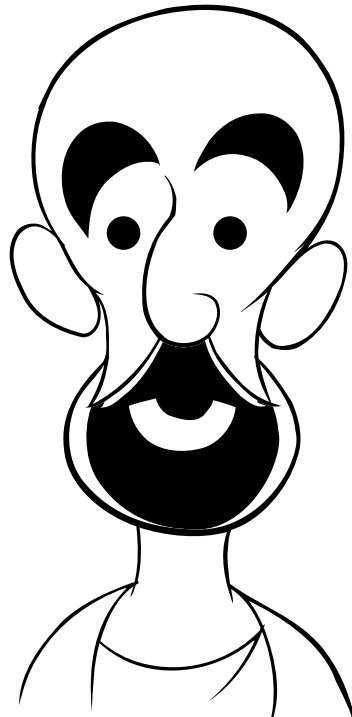

# Paul, Timothy and Lydia

**Paul Goes**  
Lesson 2

## Paul Tells Others

The children will hear of Paul's obedience to God as he told others about Jesus.

### Bible Story Text

Acts 16:1-5; 13-15

### Materials

*For the teacher:*

- Bible
- scrapbook from the Unit 24 Lesson 1, Bible Story

### Preparation

Familiarize yourself with the story and practice telling it with the scrapbook.

### Go and Tell

*I have been working on a scrapbook of our friends from the Bible. Would you like to see it? Open the scrapbook to the first page. Point to the word "Go." Can anyone tell me what this says? This is what Jesus told all of the disciples to do before he went back up to heaven. Jesus said "Go!" Can you say that with me? Where did he tell them to go? Point to the world. Everywhere! Point to the people on the world. Jesus wanted them to go all over the world to tell everyone that he loves them. Let the children touch the world. Did the disciples go? Yes! The Bible says they traveled far to teach everyone about Jesus. Open the scrapbook to the second page. Does anyone know who this is? This is Philip. Who did Philip go to teach? Yes, he taught the Ethiopian. After Philip taught the Ethiopian about Jesus, what did the Ethiopian want to do? Get baptized! Would you like to touch the water? Let each child touch the water.*

*Open the scrapbook to the third page. This is Peter. Show the children Peter and have the children repeat his name. Who is this with Peter? This is Dorcas. Who remembers what Dorcas did? That's right! She made clothes for her friends who needed help. Let each child touch the fabric.*

*Turn to the next page. Here is Peter again. He is so happy. Do you know why? He just got out of jail! Who did God send to get Peter out of jail? Yes, he sent an angel.*

*Turn to the next page. This is a new friend I want to tell you about! Open the Bible as you show the children the picture of Timothy. Timothy was a young boy who loved God very much. Do you know who taught him to love God? The Bible says his mother and his grandmother taught him about God! When he grew up he became a disciple. Can you say Timothy? Would you like to touch the Bible scroll? Let each child touch the scroll.*

*Turn to the next page. This is Paul! And guess who this is? This is Paul's great friend, Timothy. He's all grown up now! Do you know what they are doing? They love to preach to people. They are telling them, "God made the trees. God made the grass. God made the flowers." Timothy and Paul taught many people to love God and many people were baptized and became disciples. Let the children touch the greenery and the flowers.*

*Turn to the next page. Here is one of the women who studied the Bible! Her name is Lydia. Can you say Lydia? Lydia loved God very much and she helped her whole family to become disciples! After she was baptized, she invited Paul and Timothy to her house for dinner. Lydia sold beautiful purple cloth. Would you like to touch the cloth Lydia sold? As each child touches the cloth ask what color it is.*

NOTE: Save the scrapbook for the Unit 24 Lesson 3, Bible Story.

### Conclusion

Briefly, review the book with the children, pointing to each person and letting the children tell you their name.

### Teacher Tips

- Use plastic or silk leaves and flowers, they will last longer.



# Paul, Timothy and Lydia

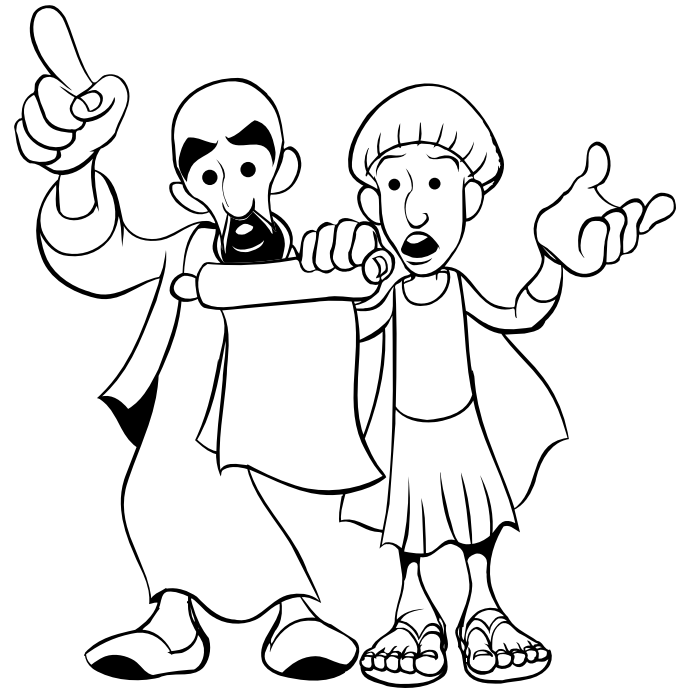

# Paul, Timothy and Lydia

## God's Preachers

The children will sing and talk about loving Jesus just like Paul did.

### Bible Truth

Paul obeyed God.  
(Acts 23:1)

### Materials

For the teacher:

- Bible
- puppet from the Unit 24 Lesson 1, Life Application

### Preparation

Familiarize yourself with the activity.

### Instructions

1. Have the children sit in a circle. Open the Bible. *In the Bible, we have been learning about Peter and how he obeyed God. Now we are learning about Paul and Timothy and how they obeyed God. Can you say Paul? Can you say Timothy?*
2. Show the children the clothespin puppet. Have the puppet ask each child: *What is your name?*
3. Have the puppet say: *Paul and Timothy told other people that they should love God. Do you love God? Do you want to obey God?* Have each child answer.
4. Have the puppet lead the children in singing "Jesus Loves Me" from the Unit 24 Song Sheet.
5. Have the puppet lead the children in prayer.
6. Have the puppet lead the children in a game of "Jesus says." *Let's stand up and play a game. When I tell you that Jesus says to do something then you get to do it. But listen closely. If I don't say "Jesus says" then don't do what I say.* Play the game with the following commands:
  - *Jesus says to hug a friend.*
  - *Jesus says to say "Amen"!*
  - *Jesus says to say "I love you" to a friend.*
  - *Jesus says to hug your teacher!*
  - *Jesus says for your teacher to hug you!*
  - *Sit down. Oh, Jesus didn't say to sit down.*

### Bible Truth Activity

Open the Bible. *The Bible is God's word. In the Bible, we read about Paul. The Bible says Paul obeyed God. Can you say that with me? "Paul obeyed God." Who wants to be like Paul and obey God? Sing "Learning To Obey" from the Unit 24 Song Sheet.*

### Conclusion

*Let's pray to God. Dear God, help us to be like Paul. Help us to love you and obey you.*

*Who are you going to tell about Bible class today? What are you going to tell them?*

### Teacher Tips

- Add more actions to the game and play again if there is time.

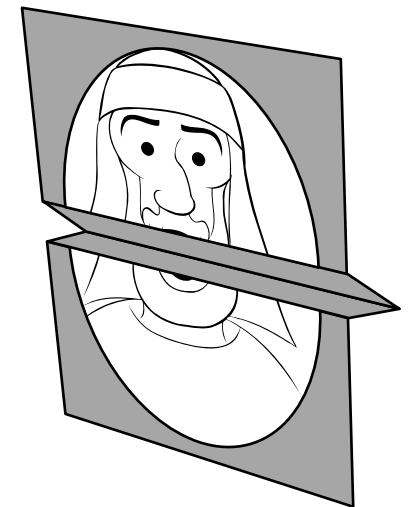
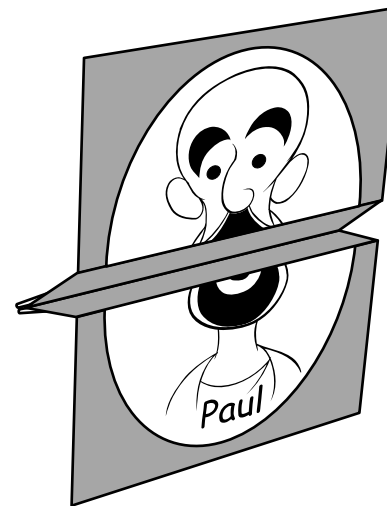

# Paul obeyed God.



# Craft

## Paul, Timothy and Lydia

### Paul and Timothy Preach

The children will make puppets of Paul and Timothy.

#### Materials

*For each child:*

- 2 spring-type clothespins
- 2 half sheets of construction paper (each half a different color)
- glue stick
- crayons

*For the teacher:*

- Bible
- crayons or markers
- scissors
- tacky or white glue

*Reproducible Pages:*

- Page A, 1 copy for each child
- Page B, 1 copy for each child

#### Preparation

1. Cut out the faces and the text boxes from the copies of Reproducible Pages A and B.
2. Cut two half sheets of construction paper for each child.
3. Fold each half sheet of construction paper in half.
4. Fold each side of the construction paper back towards the folded crease, leaving a 1½" base. See Figure A.
5. Open the clothespin and place glue on the inside on both the top and bottom of the clothespin. See Figure B.
6. Open the clothespin and attach it to the base of the construction paper making a puppet base. See Figure C.
7. Make a model of the craft following the instructions.

#### Instructions

1. Show the children the model of the craft. Have the puppets introduce themselves to the children. *We are going to make a Paul and a Timothy puppet for you to take home.*
2. Give each child a Paul face and a Timothy face to color.
3. Cut the Paul face in half on the solid line.
4. Give each child a prepared puppet base.
5. Help the children to glue the top of Paul's face to the top of the base and the bottom of Paul's face to the bottom of the base. See Figure D.
6. Cut Timothy's face in half on the solid line and have the children glue it to the second base.
7. Glue the text boxes to the construction paper behind the head.
8. Write the children's names on the back of each of their crafts.

#### Conclusion

Have the children talk to each other with their puppets.

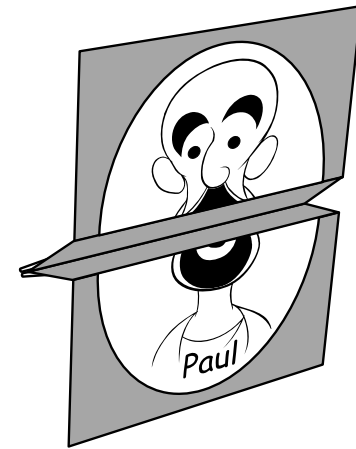

# Paul, Timothy and Lydia

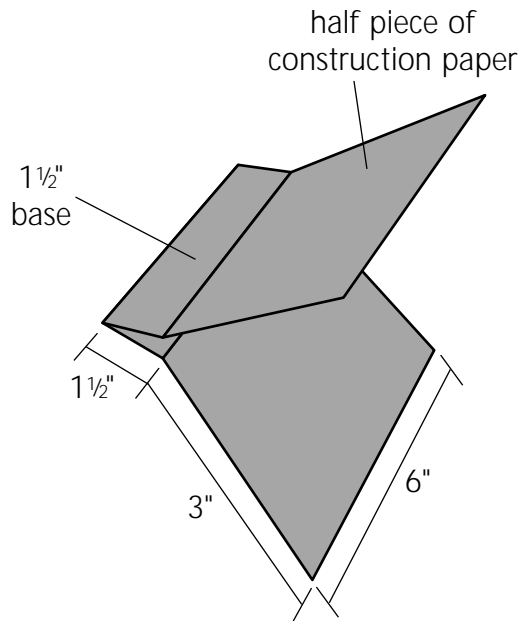

Figure A

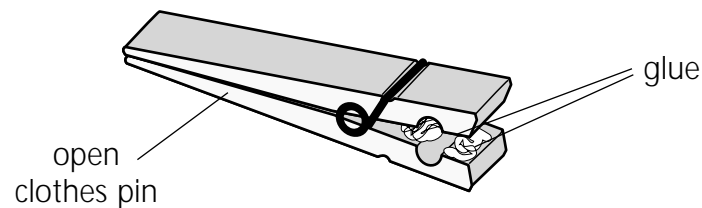

Figure B

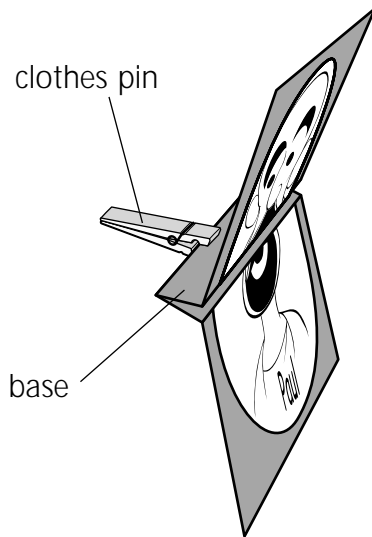

Figure C

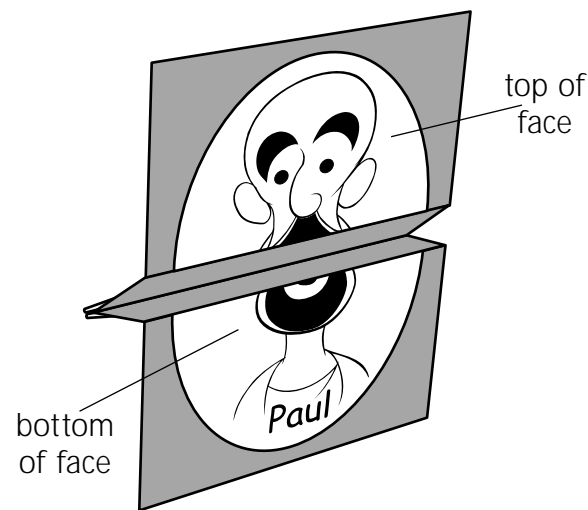

Figure D





# Paul, Timothy and Lydia

## Paul Goes

Lesson 2

Lesson at a Glance supplement



Pre class activity

### Lesson Objectives

- The children will name Paul and Timothy as people who taught others about Jesus.
- The children will say, "Lydia," when asked, "Who invited Paul and Timothy to her home?"
- The children will role-play having someone into their home.

### Bible Story Text

Acts 16:1-5; 13-15

### Bible Truth

Paul obeyed God.  
(Acts 23:1)

### Preclass Centers

As the children arrive, guide them to a preclass center. Have no more than six children at each center.

#### Materials

Use the materials previously selected for this unit's preclass centers.

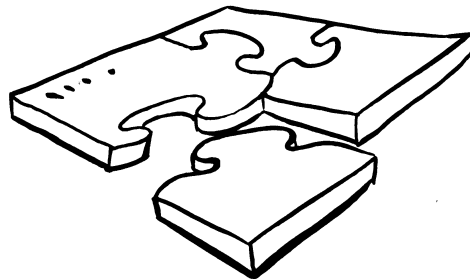

### Preparation

1. Be sure to check the condition of the materials selected for this unit's preclass centers prior to set up. Replace any broken toys, or puzzles with missing pieces as necessary.
2. Set up the centers before the children come into the classroom.
3. Assign a teacher to each center and have the teachers stay in those centers until the singing begins.

### Instructions

Guide the play in each center reinforcing the unit theme.

### Lesson Plan

Greeting and Registration

Preclass Activity: Preclass Centers

Welcome and Singing

Centers:

Life Application: Welcome

Bible Story: Paul Tells Others

Craft: Lydia's Bracelet

NOTE: Be sure to allow sufficient time for a snack.

### Teacher Tips

- **IMPORTANT:** Do not allow any small toys in the classroom. First check all toys for size. You can obtain a "safety cylinder" from a pediatrician. Any object that can fit into the cylinder is too small and could cause a child to choke.
- Be involved in the group play and offer guidance as needed.
- Wear comfortable clothes suitable for sitting on the floor.
- Smile! Be childlike in heart and alert in mind.

Life

Application

## Welcome

The children will practice hospitality.

### Bible Truth

Paul obeyed God.  
(Acts 23:1)

### Materials

For the teacher:

- Bible
- dollhouse
- dolls or toy people figures to fit in the dollhouse

### Preparation

Familiarize yourself with the activity.

### Instructions

Open the Bible. *We are learning about a woman that Paul and Timothy baptized. She was so grateful to learn about God and get baptized that she invited Paul and Timothy to come to her house to thank them. Do you remember her name? Yes, it is Lydia. What do you think Lydia gave to them when they came to her house?* Allow the children to respond (a hug, some food, a chair, etc.)

*What should we do when someone comes to our house to visit our family? Demonstrate with each other. Should we give hugs? Hug a child. Or ask them if they would like a drink? Ask another child if they would like a drink. Should we ask them if they would like something to eat? Or offer them a place to sit down? If they are children, should we let them play with our toys? If they are adults, should we let them talk to our daddy or mommy without being loud or without whining? There is so much that we can do to help people be happy when they are in our home. It's called hospitality.* Have the children repeat the word with you.

Show the children the dollhouse. *Here is our playhouse. We are going to pretend that we live in this house and our friends are coming to our house for a visit.*

Using the dolls and the dollhouse, act out a few of the scenarios that you just discussed with the children. Give a child a doll and tell them that this is the friend that is coming to visit. Have each child take a turn with the doll and play the hostess, welcoming their friends into their home.

### Bible Truth Activity

Open the Bible. *The Bible is God's word. In the Bible, we read about Paul. The Bible says Paul obeyed God. Can you say that with me? "Paul obeyed God." Who wants to be like Paul and obey God? Who can remember the name of the woman that Paul and Timothy baptized who became their friend and invited them to her house? That's right! Lydia!*

### Conclusion

*Let's pray to God. Dear God, help us to be like Paul. Help us to love you and obey you. Help us to be like Lydia and to be a great friend when people come over to our house.*

*Who are you going to tell about Bible class today? What are you going to tell them?*

If time remains, give the children a chance to reenact the scenes with the dolls. This time have them act as the host.

### Teacher Tips

- If necessary, create your own dollhouse using a cardboard box and magazine pictures of furniture.
- You may want to briefly discuss with the children that they should never allow people into their home without their mommy's or daddy's permission.



## Paul Tells Others

The children will hear of Paul's obedience to God as he told others about Jesus.

### Bible Story Text

Acts 16:1-5; 13-15

### Materials

For the teacher:

- Bible
- scrapbook from the Unit 24 Lesson 1, Bible Story

### Preparation

Familiarize yourself with the story and practice telling it with the scrapbook.

### Go and Tell

*I have been working on a scrapbook of our friends from the Bible. Would you like to see it?* Open the scrapbook to the first page. Point to the word "Go." *Can anyone tell me what this says? This is what Jesus told all of the disciples to do before he went back up to heaven. Jesus said "Go!" Can you say that with me? Where did he tell them to go?* Point to the world. *Everywhere!* Point to the people on the world. *Jesus wanted them to go all over the world to tell everyone that he loves them.* Let the children touch the world. *Did the disciples go? Yes! The Bible says they traveled far to teach everyone about Jesus.* Open the scrapbook to the second page. *Does anyone know who this is? This is Philip. Who did Philip go to teach? Yes, he taught the Ethiopian. After Philip taught the Ethiopian about Jesus, what did the Ethiopian want to do? Get baptized! Would you like to touch the water?* Let each child touch the water.

Open the scrapbook to the third page. *This is Peter. Show the children Peter and have the children repeat his name. Who is this with Peter? This is Dorcas. Who remembers what Dorcas did? That's right! She made clothes for her friends who needed help.* Let each child touch the fabric.

Turn to the next page. *Here is Peter again. He is so happy. Do you know why? He just got out of jail! Who did God send to get Peter out of jail? Yes, he sent an angel.*

Turn to the next page. *This is a new friend I want to tell you about! Open the Bible as you show the children the picture of Timothy. Timothy was a young boy who loved God very much. Do you know who taught him to love God? The Bible says his mother and his grandmother taught him about God! When he grew up he became a disciple. Can you say Timothy? Would you like to touch the Bible scroll?* Let each child touch the scroll.

Turn to the next page. *This is Paul! And guess who this is? This is Paul's great friend, Timothy. He's all grown up now! Do you know what they are doing? They love to preach to people. They are telling them, "God made the trees. God made the grass. God made the flowers." Timothy and Paul taught many people to love God and many people were baptized and became disciples.* Let the children touch the greenery and the flowers.

Turn to the next page. *Here is one of the women who studied the Bible! Her name is Lydia. Can you say Lydia? Lydia loved God very much and she helped her whole family to become disciples! After she was baptized, she invited Paul and Timothy to her house for dinner. Lydia sold beautiful purple cloth. Would you like to touch the cloth Lydia sold? As each child touches the cloth ask what color it is.*

NOTE: Save the scrapbook for the Unit 24 Lesson 3, Bible Story.

### Conclusion

Briefly, review the book with the children, pointing to each person and letting the children tell you their name.

### Teacher Tips

- Use plastic or silk leaves and flowers, they will last longer.

# Paul, Timothy and Lydia

B  
i  
b  
l  
e  
s  
t  
o  
r  
y



## Lydia's Bracelet

The children will make a bracelet to remind them of Lydia becoming a Christian.

### Materials

*For each child:*

- ½ toilet paper roll
- 1 piece of construction paper, 3" x 5"
- purple and other colored foam, fabric or construction paper scraps

*For the teacher:*

- tacky or white glue
- scissors
- black marker

### Preparation

1. Cut each toilet paper roll in half.
2. Cut along the side of each half toilet paper roll. See Figure A.
3. Cut a 3" x 5" rectangle of construction paper for each child and glue it onto each half roll. See Figure B.
4. Cut scrap pieces of colored foam into small jewel shapes.
5. Make a model of the craft following the instructions.

### Instructions

1. Put the bracelet on and show the children Lydia's bracelet. Remind the children of Lydia, that she was a woman who sold purple cloth and that Paul and Timothy taught her about the Bible. Have the children point to the purple "jewel" on your bracelet.
2. Give each child a toilet paper roll bracelet.
3. Place a few drops of glue on their bracelet as they glue on "jewels" to decorate it.
4. Write the children's names on the insides of their bracelets.

### Conclusion

Let each child model their bracelet.

### Teacher Tips

- Have extra tubes for children who want to make two bracelets.
- If you want to use plastic "gems" be sure that they pass the "Safety Cylinder" test.
- Spray paint the toilet paper rolls gold before class instead of covering the tubes with construction paper.

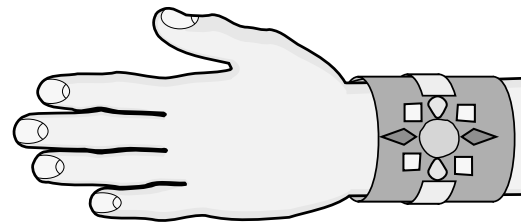

# Paul, Timothy and Lydia

C  
r  
a  
f  
t

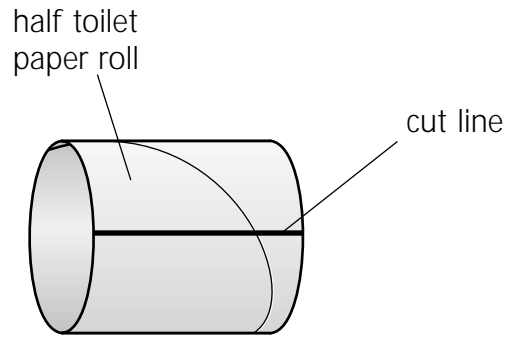

Figure A

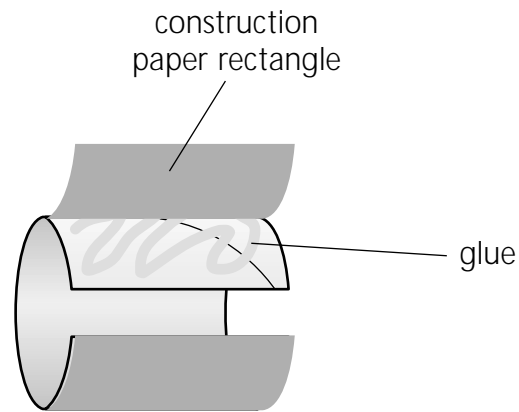
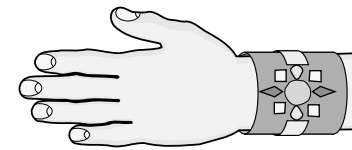

Figure B



Finished Craft





Squeeze the clothespin  
to see me talk.

R  
e  
p  
r  
o  
d  
u  
c  
e  
d  
b  
y  
e

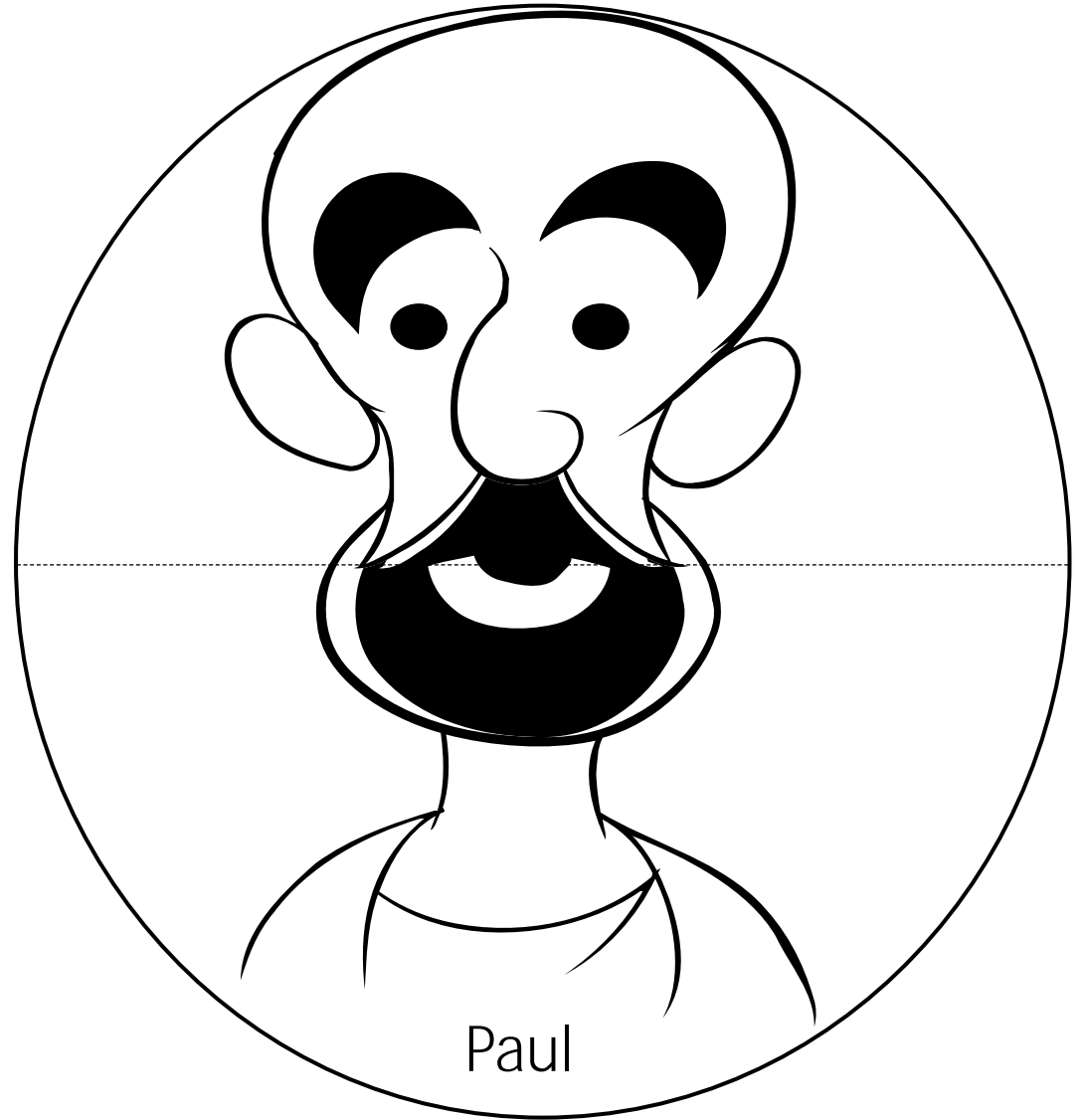

Paul





Squeeze the clothespin  
to see me talk.

R  
e  
p  
r  
e  
s  
e  
n  
t  
a  
t  
i  
o  
n

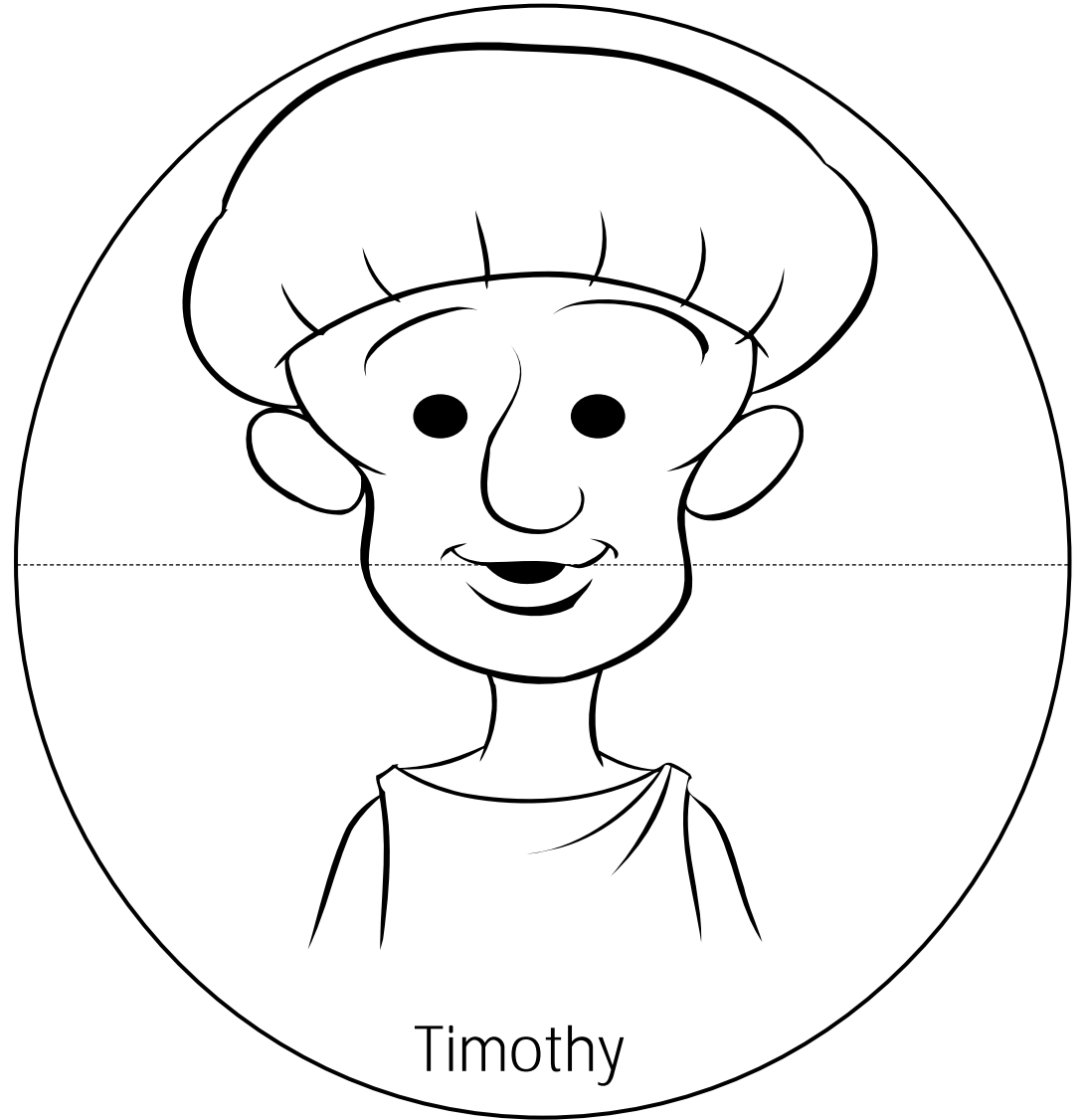

Timothy

