

# Paul and Timothy

**Paul Goes**  
Lesson 1

## Lesson Objectives

- The children will name Paul and Timothy as people who taught others about Jesus.
- The children will say, "Lydia," when asked, "Who invited Paul and Timothy to her home?"
- The children will role-play having someone into their home.

## Bible Story Text

Acts 16:1-5; 13-15

## Bible Truth

Paul obeyed God.  
(Acts 23:1)

## Lesson Plan

Greeting and Registration

Preclass Activity: Preclass Centers

Welcome and Singing

Centers:

Bible Story: Paul Tells Others

Life Application: God's Preachers

Craft: Timothy Loves God

NOTE: Be sure to allow sufficient time for a snack.

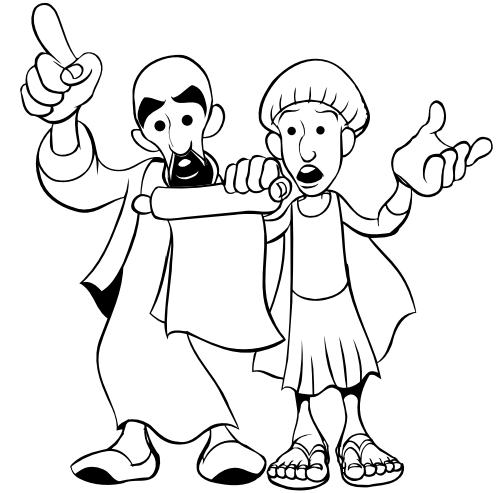

# Paul and Timothy

## Preclass Centers

In the preclass centers children will use language, motor, and cognitive skills, learn to interact with peers and cooperate in small groups.

Select four centers to use this unit. Assign a teacher to set up and supervise each center with no more than six children.

### Materials

**IMPORTANT:** Do not allow any small toys in the classroom. First check all toys for size. You can obtain a "safety cylinder" from a pediatrician. Any object that can fit into the cylinder is too small and could cause a child to choke.

- Housekeeping Center—2 washable dolls (of diverse ethnicity, e.g., black and white), play food, dishes and 2 small blankets
- Story Center—simple books with limited text (cardboard are the most sturdy and durable) and large pillows
- Block Center—set of large blocks, people, animal figures (plastic or wooden) and toy cars
- Puzzle Center—1 puzzle for each child (for twos each puzzle piece itself should be a complete familiar object, for threes most can complete a 20-piece puzzle). **NOTE:** A puzzle should have all the pieces. If a puzzle piece is lost, the entire puzzle should be thrown out.

### Instructions

Guide the play in each center reinforcing the unit theme. Refer to the following example for help in directing play and asking relevant questions.

In the Housekeeping Center, ask the children: *Who is coming over for dinner today? God loves it when we have people to our house. It is called hospitality. Let's cook dinner for our friends.*

### Teacher Tips

- You may want to try other centers such as transportation, large motor or manipulative.
- Wear comfortable clothes suitable for sitting on the floor.

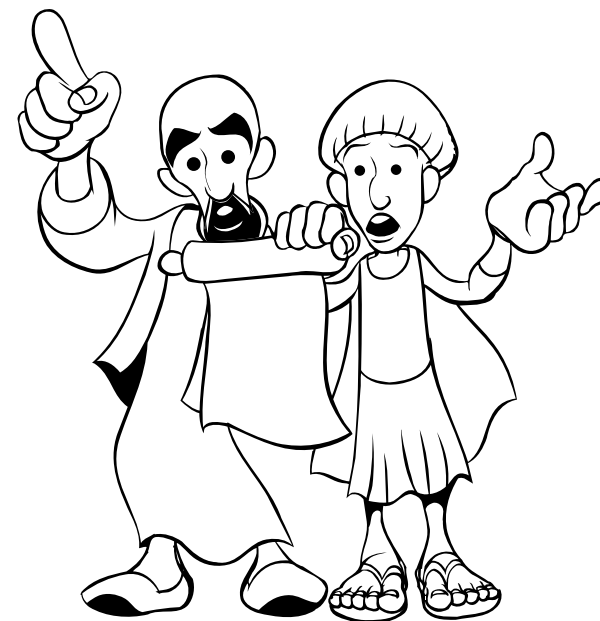

# Paul and Timothy

**Paul Goes**

Lesson 1

## Paul Tells Others

The children will hear of Paul's obedience to God as he told others about Jesus.

### Bible Story Text

Acts 16:1-5; 13-15

### Materials

*For the teacher:*

- Bible
- scissors
- 10 pieces of black construction paper
- blue construction paper circle, 5"
- brightly colored yarn or ribbon, 12"
- hole punch
- glue
- crayons or markers
- blue cellophane, 4" x 4"
- 5" square of purple cloth
- 5" square of colorful cloth, other than purple
- a piece of brown paper bag, 1/2" x 1"
- leaves and sticks

*Reproducible Pages:*

- Page A, 1 copy for the teacher
- Page B, 1 copy for the teacher

### Preparation

1. Cut out the pictures from the copies of Reproducible Pages A and B.
2. Stack the pages of construction paper and punch three holes along one of the 9" sides to form a book.
3. Cut three 4" pieces of yarn. Tie one piece to each hole in the book.
4. Make a "Friends in Acts" scrapbook:
  - A. On the cover of the book write "Friends in Acts."
  - B. For the first page, cut out a blue construction paper circle as the world and glue it onto the page. Draw people on it. Above the world write "Go" in large letters.
  - C. Color and glue the picture of Philip and the Ethiopian onto the second page. Glue a piece of blue cellophane onto the picture as water.

- D. Color and glue the picture of Peter and Dorcas to the third page. Glue a piece of colored cloth on the page next to Dorcas.
- E. Color and glue the picture of Peter out of jail onto the fourth page.
- F. Color and glue the picture of young Timothy onto the fifth page. Cut a 1/2" x 1" piece of paper bag. Draw lines on it as writing and glue the paper to Timothy's hand.
- G. Color and glue the picture of Paul and Timothy preaching onto the sixth page. Glue leaves and sticks around them.
- H. Color and glue the picture of Lydia welcoming Paul and Timothy onto the seventh page. Glue the piece of purple cloth onto the picture.
- I. Leave the last two pages blank.

### Go and Tell

*I have been working on a scrapbook of our friends from the Bible. Would you like to see it? Open the scrapbook to the first page. Point to the word "Go." Can anyone tell me what this says? This is what Jesus told all of the disciples to do before he went back up to heaven. Jesus said "Go!" Can you say that with me? Where did he tell them to go? Point to the world. Everywhere! Point to the people on the world. Jesus wanted them to go all over the world to tell everyone that he loves them. Let the children touch the world. Did the disciples go? Yes! The Bible says they traveled far to teach everyone about Jesus. Open the scrapbook to the second page. Does anyone know who this is? This is Philip. Who did Philip go to teach? Yes, he taught the Ethiopian. After Philip taught the Ethiopian about Jesus, what did the Ethiopian want to do? Get baptized! Would you like to touch the water? Let each child touch the water.*

Open the scrapbook to the third page. *This is Peter. Show the children Peter and have the children repeat his name. Who is this with Peter? This is Dorcas. Who remembers what Dorcas did? That's right! She made clothes for her friends who needed help. Let each child touch the fabric.*

Turn to the next page. *Here is Peter again. He is so happy. Do you know why? He just got out of jail! Who did God send to get Peter out of jail? Yes, he sent an angel.*



# Paul and Timothy

Turn to the next page. *This is a new friend I want to tell you about!* Open the Bible as you show the children the picture of Timothy. *Timothy was a young boy who loved God very much. Do you know who taught him to love God? The Bible says his mother and his grandmother taught him about God! When he grew up he became a disciple. Can you say Timothy? Would you like to touch the Bible scroll?* Let each child touch the scroll.

Turn to the next page. *This is Paul! And guess who this is? This is Paul's great friend, Timothy. He's all grown up now! Do you know what they are doing? They love to preach to people. They are telling them, "God made the trees. God made the grass. God made the flowers." Timothy and Paul taught many people to love God and many people were baptized and became disciples.* Let the children touch the greenery and the flowers.

Turn to the next page. *Here is one of the women who studied the Bible! Her name is Lydia. Can you say Lydia? Lydia loved God very much and she helped her whole family to become disciples! After she was baptized, she invited Paul and Timothy to her house for dinner. Lydia sold beautiful purple cloth. Would you like to touch the cloth Lydia sold?* As each child touches the cloth ask what color it is.

NOTE: Save the scrapbook for the Unit 24 Lesson 2, Bible Story.

## Conclusion

Briefly, review the book with the children, pointing to each person and letting the children tell you their name.

## Teacher Tips

- Use plastic or silk leaves and flowers, they will last longer.

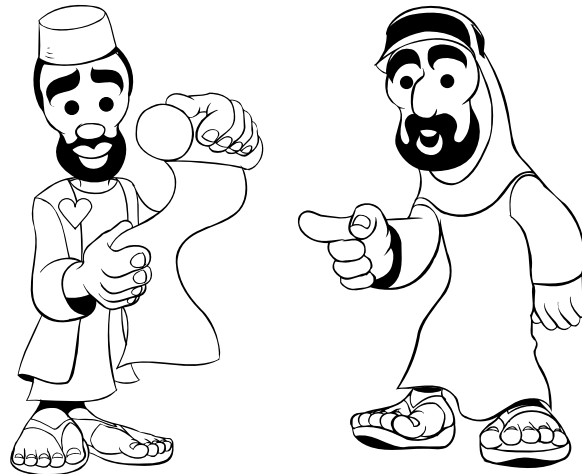
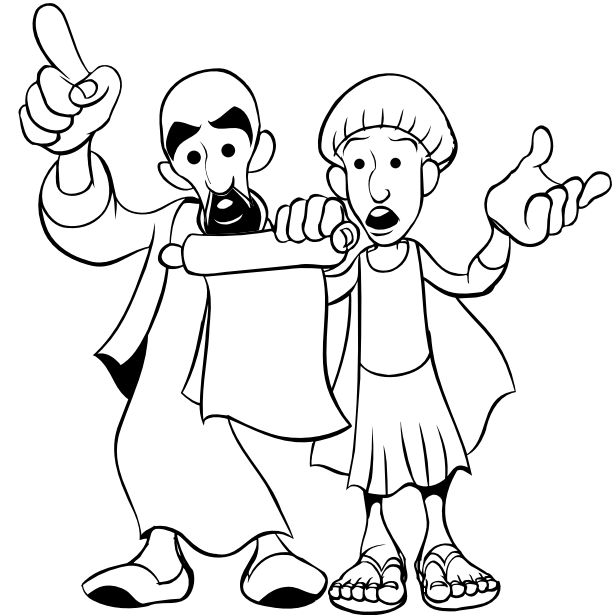

# Paul and Timothy

## God's Preachers

The children will sing and talk about loving Jesus just like Paul did with a puppet.

### Bible Truth

Paul obeyed God.  
(Acts 23:1)

### Materials

*For the teacher:*

- Bible
- ½ sheet of construction paper, (6" x 9")
- spring-type clothespin
- crayons or markers
- scissors
- tacky glue or white glue

*Reproducible Pages:*

- Page C, 1 copy for the teacher

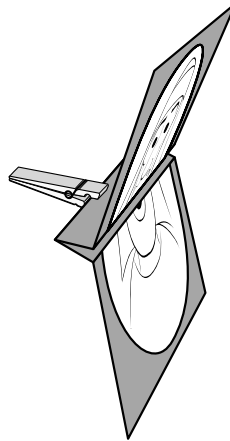

### Preparation

1. Cut out and color the face from the copy of Reproducible Page C.
2. Cut a sheet of construction paper in half.
3. Fold each piece of construction paper in half.
4. Fold each end back to the folded edge leaving a 1½" base. See Figure A.
5. Cut the face in half on the solid line.
6. Glue each piece of the face onto each side of the folded construction paper as shown in Figure B.
7. Open the clothespin and place glue on the inside on both the top and bottom of the clothespin. See Figure C.
8. Attach the clothespin to the base of the construction paper face. See Figure D.
9. Open the clothespin to ensure that the mouth opens and closes together as a puppet "talking."

### Instructions

1. Have the children sit in a circle. Open the Bible. *In the Bible, we have been learning about Peter and how he obeyed God. Now we are learning about Paul and Timothy and how they obeyed God. Can you say Paul? Can you say Timothy?*

2. Show the children the clothespin puppet. Have the puppet ask each child: *What is your name?*
3. Have the puppet say: *Paul and Timothy told other people that they should love God. Do you love God? Do you want to obey God?* Have each child answer.
4. Have the puppet lead the children in singing "Jesus Loves Me" from the Unit 24 Song Sheet.
5. Have the puppet lead the children in prayer.
6. Have the puppet lead the children in a game of "Jesus says." *Let's stand up and play a game. When I tell you that Jesus says to do something then you get to do it. But listen closely. If I don't say "Jesus says" then don't do what I say.* Play the game with the following commands:
  - *Jesus says to hug a friend.*
  - *Jesus says to say "Amen"!*
  - *Jesus says to say "I love you" to a friend.*
  - *Jesus says to hug your teacher!*
  - *Jesus says for your teacher to hug you!*
  - *Sit down. Oh, Jesus didn't say to sit down.*

NOTE: Save the puppet for the Unit 24 Lesson 2, Life Application.

### Bible Truth Activity

Open the Bible. *The Bible is God's word. In the Bible, we read about Paul. The Bible says Paul obeyed God. Can you say that with me? "Paul obeyed God." Who wants to be like Paul and obey God?* Sing "Learning To Obey" from the Unit 24 Song Sheet.

### Conclusion

*Let's pray to God. Dear God, help us to be like Paul. Help us to love you and obey you.*

*Who are you going to tell about Bible class today? What are you going to tell them?*

### Teacher Tips

- Add more actions to the game and play again if there is time.

# Paul and Timothy

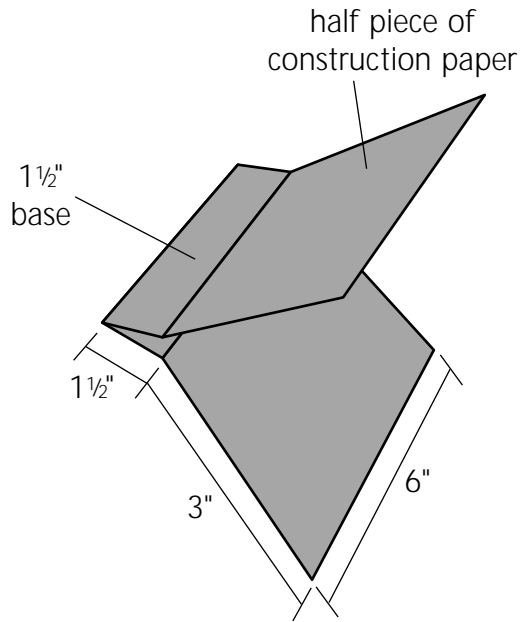

Figure A

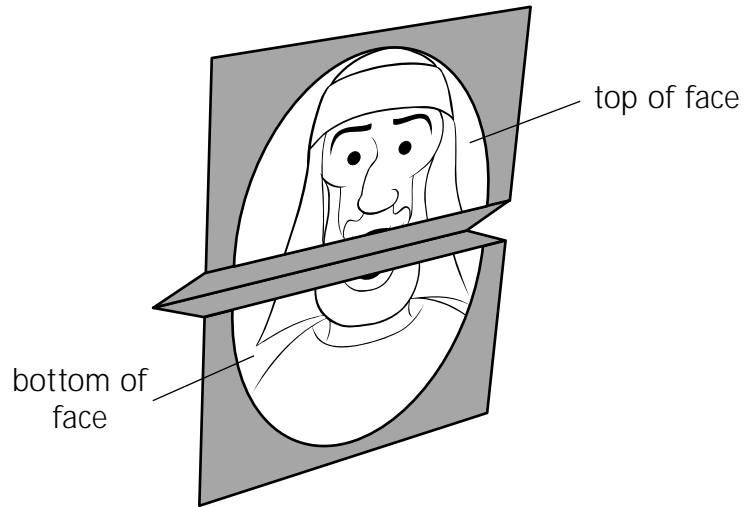

Figure B

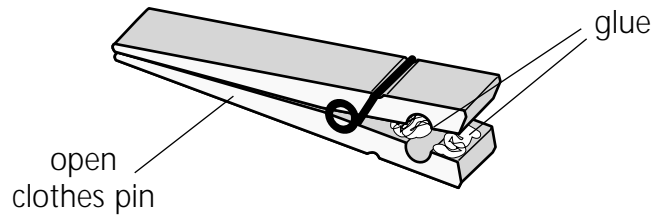

Figure C

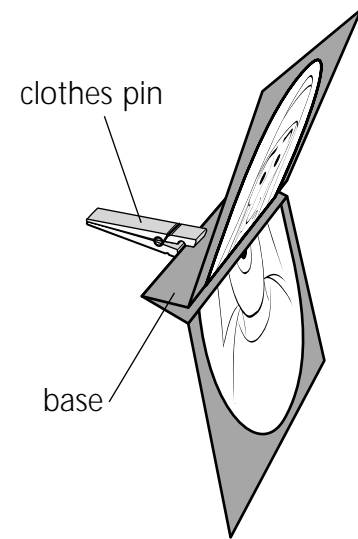

Figure D



C  
r  
a  
f  
t

# Paul and Timothy

## Timothy Loves God

The children will make a picture of Timothy as a little boy learning from a Bible scroll with his mother and grandmother.

### Materials

*For each child:*

- 1 piece of brightly colored construction paper
- 2 pieces of a drinking straw, 3"
- 8 pieces of yarn, 2"
- 1 piece of brown construction paper, 2<sup>3</sup>/<sub>4</sub>" x 4"
- crayons
- glue stick

*For the teacher:*

- scissors
- ruler
- tacky or white glue
- tape
- marker

*Reproducible Pages:*

- Page D, 1 copy for each child

### Preparation

1. Cut out the pictures from the copies of Reproducible Page D.
2. Cut the drinking straws into 3" pieces, two for each child.
3. Cut a 2<sup>3</sup>/<sub>4</sub>" x 4" piece of brown construction paper for each child.
4. Glue one piece of straw to each end of a piece of brown construction paper creating a "scroll." See Figure A.
5. After the glue dries, roll both straws toward the center of the scroll and tape it together. See Figure B.
6. Cut eight 2" pieces of yarn for each child.
7. Make a model of the craft following the instructions.

### Instructions

1. Show the children the model of the craft. Name the people in the picture: *This is a picture of Timothy, his mother and his grandmother.* Have the children repeat the names. Point to the Bible scroll. *This is what the Bible looked like when Timothy was a little boy. You can make a picture of Timothy learning the Bible to help you remember to read your Bible.*
2. Give each child a copy of Reproducible Page D and help them glue it to the center of a piece of construction paper.
3. Help each child to glue a scroll into the grandmother's hands.
4. Give each child eight pieces of yarn to glue onto the mother, grandmother and Timothy as hair.
5. Have the children color their pictures.
6. Write each child's name on their craft.

### Conclusion

Have each child point to the people on the craft as you say the different names: *Can you point to Timothy? Can you point to Timothy's mommy? Can you point to Timothy's grandmother? What is Timothy's grandmother reading to him? The Bible! Can you point to the Bible scroll? When Timothy was a little boy, he had to learn to obey, didn't he? Let's sing a song about Timothy. Sing "Timothy Grew and Grew" from the Unit 24 Song Sheet.*

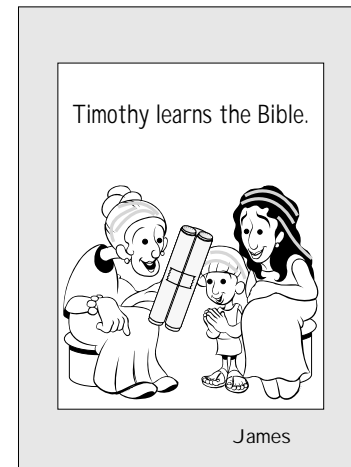

craft

# Paul and Timothy

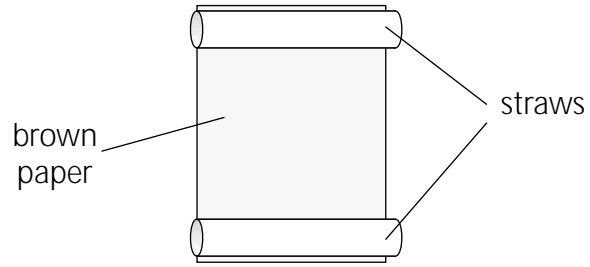

Figure A

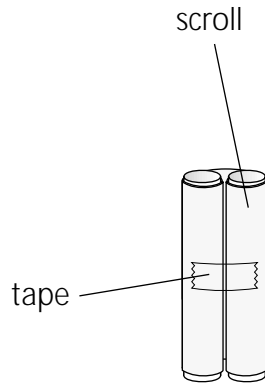
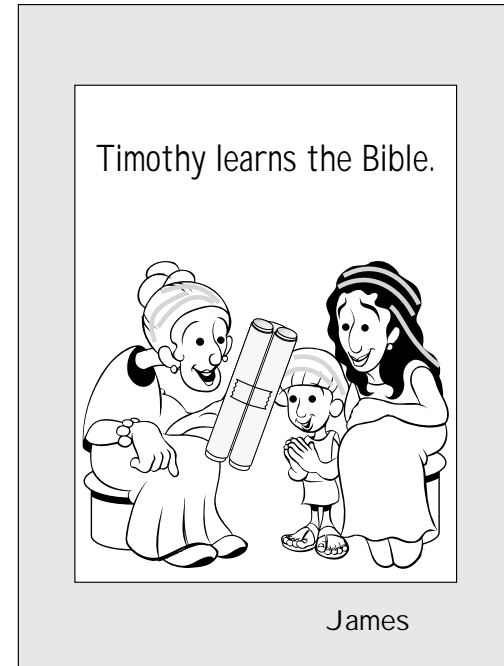

Figure B



Finished Craft







# Paul and Timothy

## Paul Goes

Lesson 1

### Lesson Objectives

- The children will name Paul and Timothy as people who taught others about Jesus.
- The children will say, "Lydia," when asked, "Who invited Paul and Timothy to her home?"
- The children will role-play having someone into their home.

### Bible Story Text

Acts 16:1-5; 13-15

### Bible Truth

Paul obeyed God.  
(Acts 23:1)

### Preclass Centers

In the preclass centers children will use language, motor, and cognitive skills, learn to interact with peers and cooperate in small groups.

Select four centers to use this unit.

Assign a teacher to set up and supervise each center with no more than six children.

#### Materials

**IMPORTANT:** Do not allow any small toys in the classroom. First check all toys for size. You can obtain a "safety cylinder" from a pediatrician. Any object that can fit into the cylinder is too small and could cause a child to choke.

- Housekeeping Center—2 washable dolls (of diverse ethnicity, e.g., black and white), play food, dishes and 2 small blankets

### Lesson Plan

Greeting and Registration

Preclass Activity: Preclass Centers

Welcome and Singing

Centers:

Life Application: Welcome

Bible Story: Paul Tells Others

Craft: Come Inside!

NOTE: Be sure to allow sufficient time for a snack.

- Story Center—simple books with limited text (cardboard are the most sturdy and durable) and large pillows
- Block Center—set of large blocks, people, animal figures (plastic or wooden) and toy cars
- Puzzle Center—1 puzzle for each child (for twos each puzzle piece itself should be a complete familiar object, for threes most can complete a 20-piece puzzle). NOTE: A puzzle should have all the pieces. If a puzzle piece is lost, the entire puzzle should be thrown out.

#### Instructions

Guide the play in each center reinforcing the unit theme. Refer to the following example for help in directing play and asking relevant questions.

In the Housekeeping Center, ask the children: *Who is coming over for dinner today? God loves it when we have people to our house. It is called hospitality. Let's cook dinner for our friends.*

#### Teacher Tips

- You may want to try other centers such as transportation, large motor or manipulative.
- Wear comfortable clothes suitable for sitting on the floor.

Life

Application

## Welcome

The children will practice hospitality.

### Bible Truth

Paul obeyed God.  
(Acts 23:1)

### Materials

For the teacher:

- Bible
- dollhouse
- dolls or toy people figures to fit in the dollhouse

### Preparation

Familiarize yourself with the activity.

### Instructions

Open the Bible. *We are learning about a woman that Paul and Timothy baptized. She was so grateful to learn about God and get baptized that she invited Paul and Timothy to come to her house to thank them. Do you remember her name? Yes, it is Lydia. What do you think Lydia gave to them when they came to her house?* Allow the children to respond (a hug, some food, a chair, etc.)

*What should we do when someone comes to our house to visit our family? Demonstrate with each other. Should we give hugs? Hug a child. Or ask them if they would like a drink? Ask another child if they would like a drink. Should we ask them if they would like something to eat? Or offer them a place to sit down? If they are children, should we let them play with our toys? If they are adults, should we let them talk to our daddy or mommy without being loud or without whining? There is so much that we can do to help people be happy when they are in our home. It's called hospitality. Have the children repeat the word with you.*

Show the children the dollhouse. *Here is our playhouse. We are going to pretend that we live in this house and our friends are coming to our house for a visit.*

Using the dolls and the dollhouse, act out a few of the scenarios that you just discussed with the children. Give a child a doll and tell them that this is the friend that is coming to visit. Have each child take a turn with the doll and play the hostess, welcoming their friends into their home.

### Bible Truth Activity

Open the Bible. *The Bible is God's word. In the Bible, we read about Paul. The Bible says Paul obeyed God. Can you say that with me? "Paul obeyed God." Who wants to be like Paul and obey God? Who can remember the name of the woman that Paul and Timothy baptized who became their friend and invited them to her house? That's right! Lydia!*

### Conclusion

*Let's pray to God. Dear God, help us to be like Paul. Help us to love you and obey you. Help us to be like Lydia and to be a great friend when people come over to our house.*

*Who are you going to tell about Bible class today? What are you going to tell them?*

If time remains, give the children a chance to reenact the scenes with the dolls. This time have them act as the host.

### Teacher Tips

- If necessary, create your own dollhouse using a cardboard box and magazine pictures of furniture.
- You may want to briefly discuss with the children that they should never allow people into their home without their mommy's or daddy's permission.



## Paul Tells Others

The children will hear of Paul's obedience to God as he told others about Jesus.

### Bible Story Text

Acts 16:1-5; 13-15

### Materials

*For the teacher:*

- Bible
- scissors
- 10 pieces of black construction paper
- blue construction paper circle, 5"
- brightly colored yarn or ribbon, 12"
- hole punch
- glue
- crayons or markers
- blue cellophane, 4" x 4"
- 5" square of purple cloth
- 5" square of colorful cloth, other than purple
- a piece of brown paper bag, 1/2" x 1"
- leaves and sticks

*Reproducible Pages:*

- Page A, 1 copy for the teacher
- Page B, 1 copy for the teacher

### Preparation

1. Cut out the pictures from the copies of Reproducible Pages A and B.
2. Stack the pages of construction paper and punch three holes along one of the 9" sides to form a book.
3. Cut three 4" pieces of yarn. Tie one piece to each hole in the book.
4. Make a "Friends in Acts" scrapbook:
  - A. On the cover of the book write "Friends in Acts."
  - B. For the first page, cut out a blue construction paper circle as the world and glue it onto the page. Draw people on it. Above the world write "Go" in large letters.
  - C. Color and glue the picture of Philip and the Ethiopian onto the second page. Glue a piece of blue cellophane onto the picture as water.

- D. Color and glue the picture of Peter and Dorcas to the third page. Glue a piece of colored cloth on the page next to Dorcas.
- E. Color and glue the picture of Peter out of jail onto the fourth page.
- F. Color and glue the picture of young Timothy onto the fifth page. Cut a 1/2" x 1" piece of paper bag. Draw lines on it as writing and glue the paper to Timothy's hand.
- G. Color and glue the picture of Paul and Timothy preaching onto the sixth page. Glue leaves and sticks around them.
- H. Color and glue the picture of Lydia welcoming Paul and Timothy onto the seventh page. Glue the piece of purple cloth onto the picture.
- I. Leave the last two pages blank.

### Go and Tell

*I have been working on a scrapbook of our friends from the Bible. Would you like to see it? Open the scrapbook to the first page. Point to the word "Go." Can anyone tell me what this says? This is what Jesus told all of the disciples to do before he went back up to heaven. Jesus said "Go!" Can you say that with me? Where did he tell them to go? Point to the world. Everywhere! Point to the people on the world. Jesus wanted them to go all over the world to tell everyone that he loves them. Let the children touch the world. Did the disciples go? Yes! The Bible says they traveled far to teach everyone about Jesus. Open the scrapbook to the second page. Does anyone know who this is? This is Philip. Who did Philip go to teach? Yes, he taught the Ethiopian. After Philip taught the Ethiopian about Jesus, what did the Ethiopian want to do? Get baptized! Would you like to touch the water? Let each child touch the water.*

*Open the scrapbook to the third page. This is Peter. Show the children Peter and have the children repeat his name. Who is this with Peter? This is Dorcas. Who remembers what Dorcas did? That's right! She made clothes for her friends who needed help. Let each child touch the fabric.*

*Turn to the next page. Here is Peter again. He is so happy. Do you know why? He just got out of jail! Who did God send to get Peter out of jail? Yes, he sent an angel.*

# Paul and Timothy

**Paul Goes**  
Lesson 1

Turn to the next page. *This is a new friend I want to tell you about!* Open the Bible as you show the children the picture of Timothy. *Timothy was a young boy who loved God very much. Do you know who taught him to love God? The Bible says his mother and his grandmother taught him about God! When he grew up he became a disciple. Can you say Timothy? Would you like to touch the Bible scroll?* Let each child touch the scroll.

Turn to the next page. *This is Paul! And guess who this is? This is Paul's great friend, Timothy. He's all grown up now! Do you know what they are doing? They love to preach to people. They are telling them, "God made the trees. God made the grass. God made the flowers." Timothy and Paul taught many people to love God and many people were baptized and became disciples.* Let the children touch the greenery and the flowers.

Turn to the next page. *Here is one of the women who studied the Bible! Her name is Lydia. Can you say Lydia? Lydia loved God very much and she helped her whole family to become disciples! After she was baptized, she invited Paul and Timothy to her house for dinner. Lydia sold beautiful purple cloth. Would you like to touch the cloth Lydia sold?* As each child touches the cloth ask what color it is.

NOTE: Save the scrapbook for the Unit 24 Lesson 2, Bible Story.

## Conclusion

Briefly, review the book with the children, pointing to each person and letting the children tell you their name.

## Teacher Tips

- Use plastic or silk leaves and flowers, they will last longer.

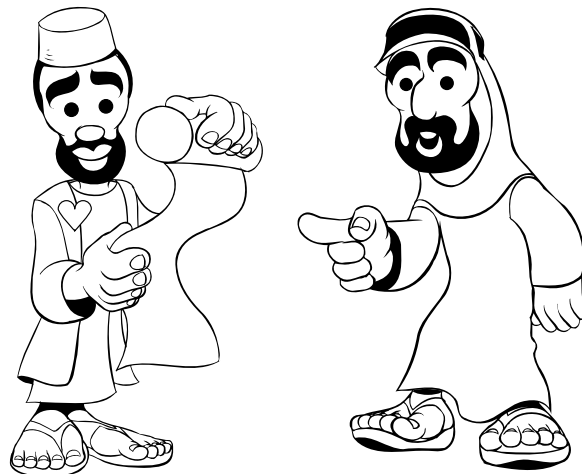
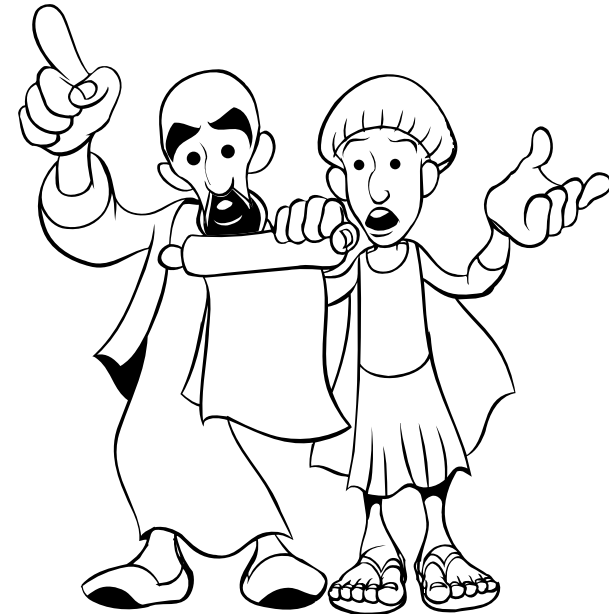

## Craft

## Come Inside!

This craft will remind the children of Lydia's hospitality.

## Materials

*For each child:*

- 2 pieces of elbow macaroni
- purple fabric, 2" x 3½"
- 1 piece of brown construction paper, 9" x 12"
- 1 piece of brown pipe cleaner, 4"
- glue stick
- crayons

*For the teacher:*

- gold spray paint
- newspapers
- scissors
- ruler
- hole punch
- black marker

*Reproducible Pages:*

- Page E, 1 copy for each child



## Preparation

1. Cut out the Lydia figures and text boxes from the copies of Reproducible Page E.
2. Make a door for each child as follows.
  - A. Fold a piece of brown construction paper in half so it is 9" x 6." See Figure A.
  - B. Punch two holes in the front of the paper where the door handle will be. See Figure A.
  - C. Cut a 4" piece of brown pipe cleaner.
  - D. Put the pipe cleaner through the holes and twist the ends together inside the door to make a handle. See Figure B.
  - E. Place a piece of tape over the pipe cleaner on the inside of the door.

3. Cut a 2" x 3½" piece of purple fabric for each child.
4. Make two bracelets from macaroni for each child as follows:
  - A. Lay the macaroni on several layers of newspaper in a well-ventilated area.
  - B. Spray one side of the macaroni gold. Allow the paint to dry and spray the other side of the macaroni.
5. Make a model of the craft following the instructions.

## Instructions

1. Show the children the model of the craft. Give each child a turn to open the door and see Lydia inside. Read the text to them each time they open the door. Remind the children of how Lydia invited Paul and Timothy into her home after she was baptized.
2. Give each child a prepared piece of construction paper and a Lydia figure. Have them glue the figure in the center, inside the door. See Figure C.
3. Have the children color the Lydia figures.
4. Give each child a piece of fabric to glue onto Lydia as a skirt.
5. Help each child to glue one piece of macaroni onto each wrist as bracelets.
6. Give each child the "Welcome to my home." text box to glue opposite the Lydia figure.
7. Have each child glue the "Lydia said " text box onto the front of the door.
8. Write each child's name on their craft.

## Conclusion

Have the children open the doors of their crafts and invite their friends in.

## Teacher Tips

- Make sure the spray paint is dry before class.

C  
r  
a  
f  
t

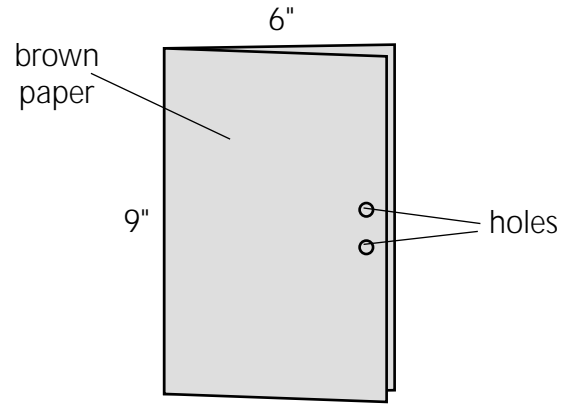

Figure A

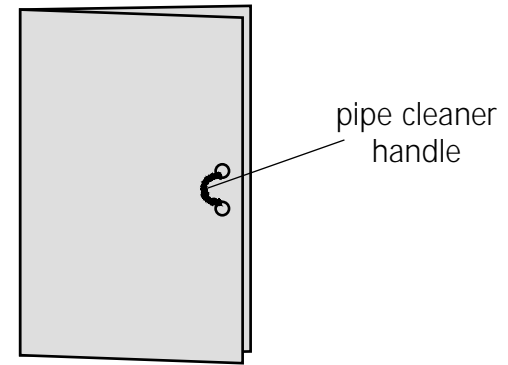

Figure B

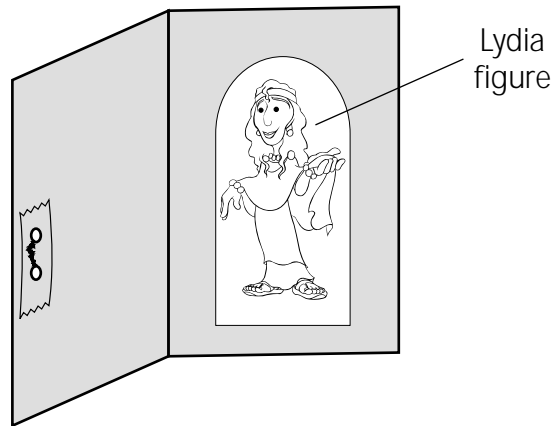
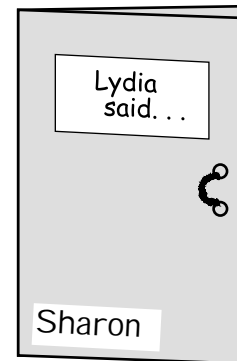
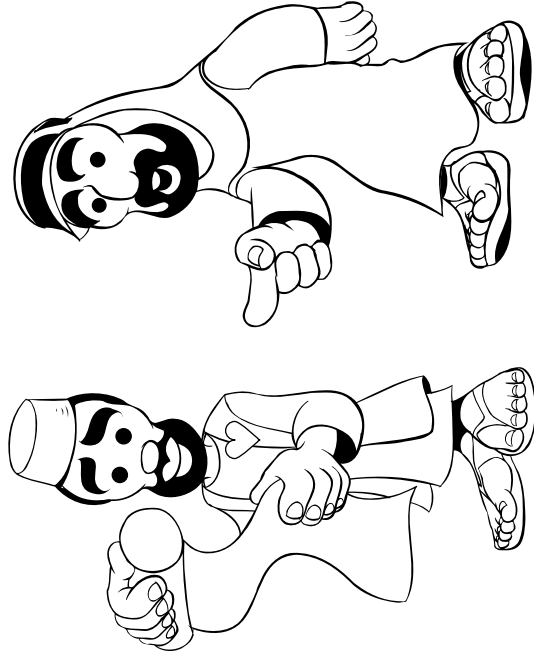

Figure C



Finished Craft





Philip teaches  
the Ethiopian

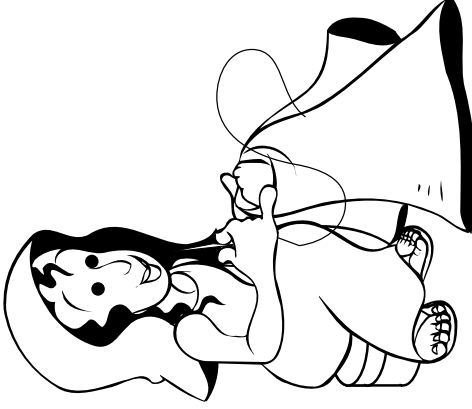

Dorcas makes clothes  
for the poor



Peter is free from jail





Timothy as a  
young man

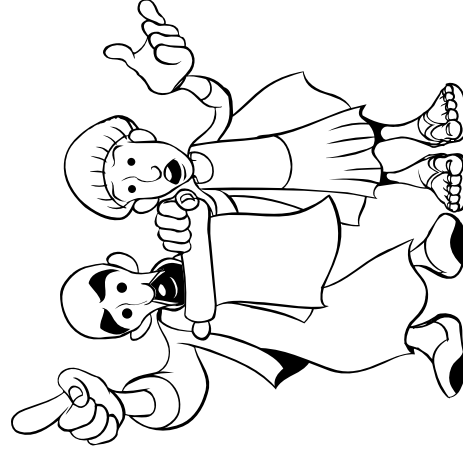
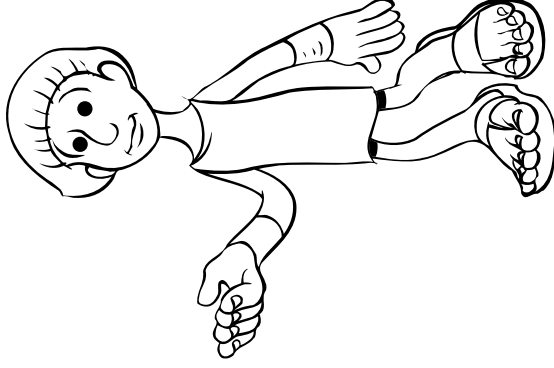

Paul and Timothy preach

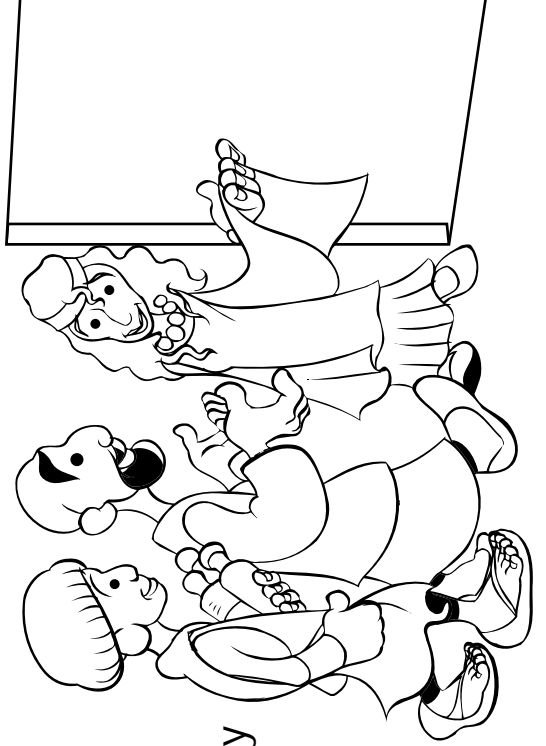

Lydia welcomes  
Paul and Timothy







R  
e  
p  
o  
r  
t  
e  
r  
e  
-  
b  
-  
c  
-  
u  
-  
c  
-  
i  
-  
b  
-  
e

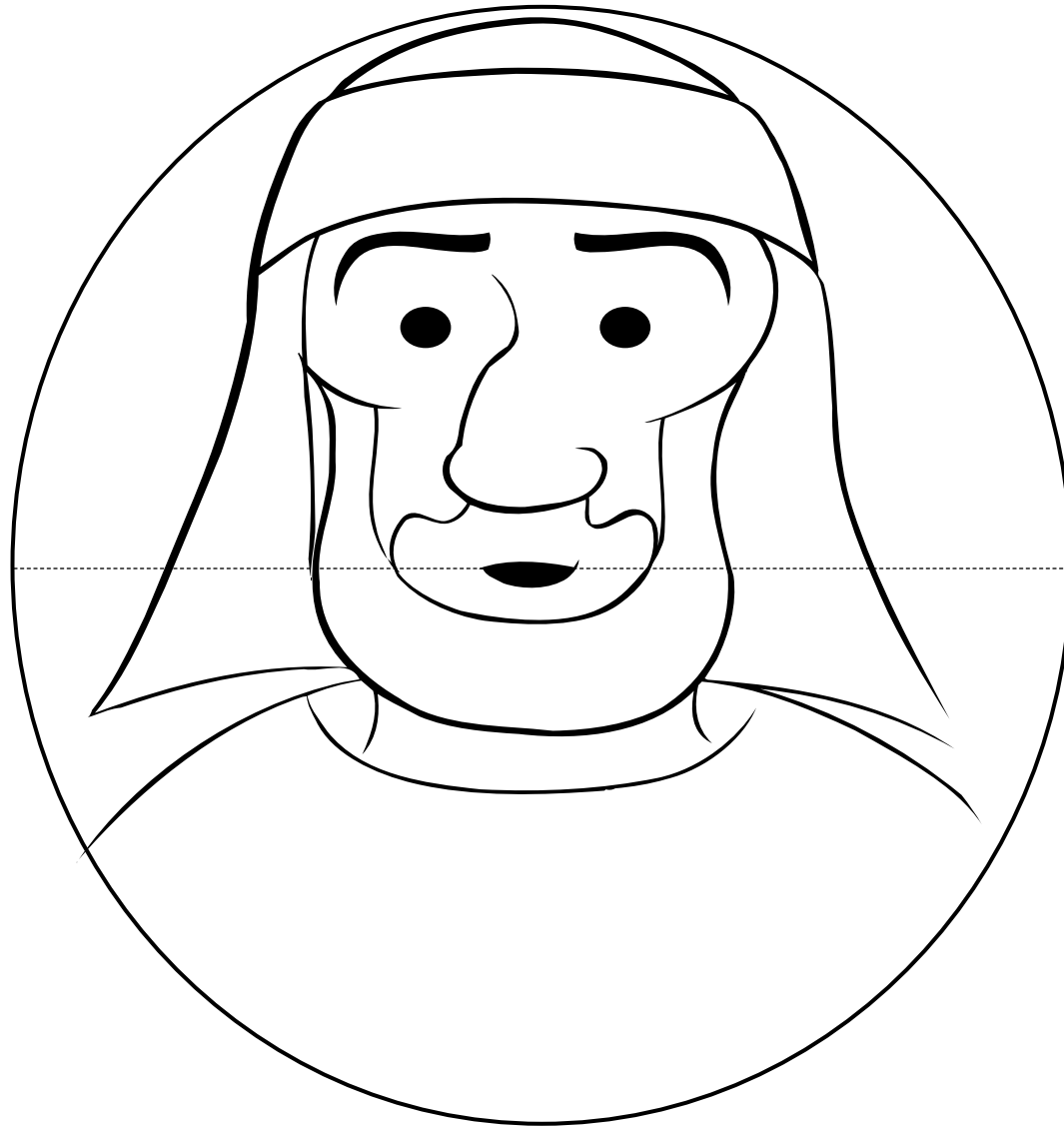

face





# Timothy learns the Bible.

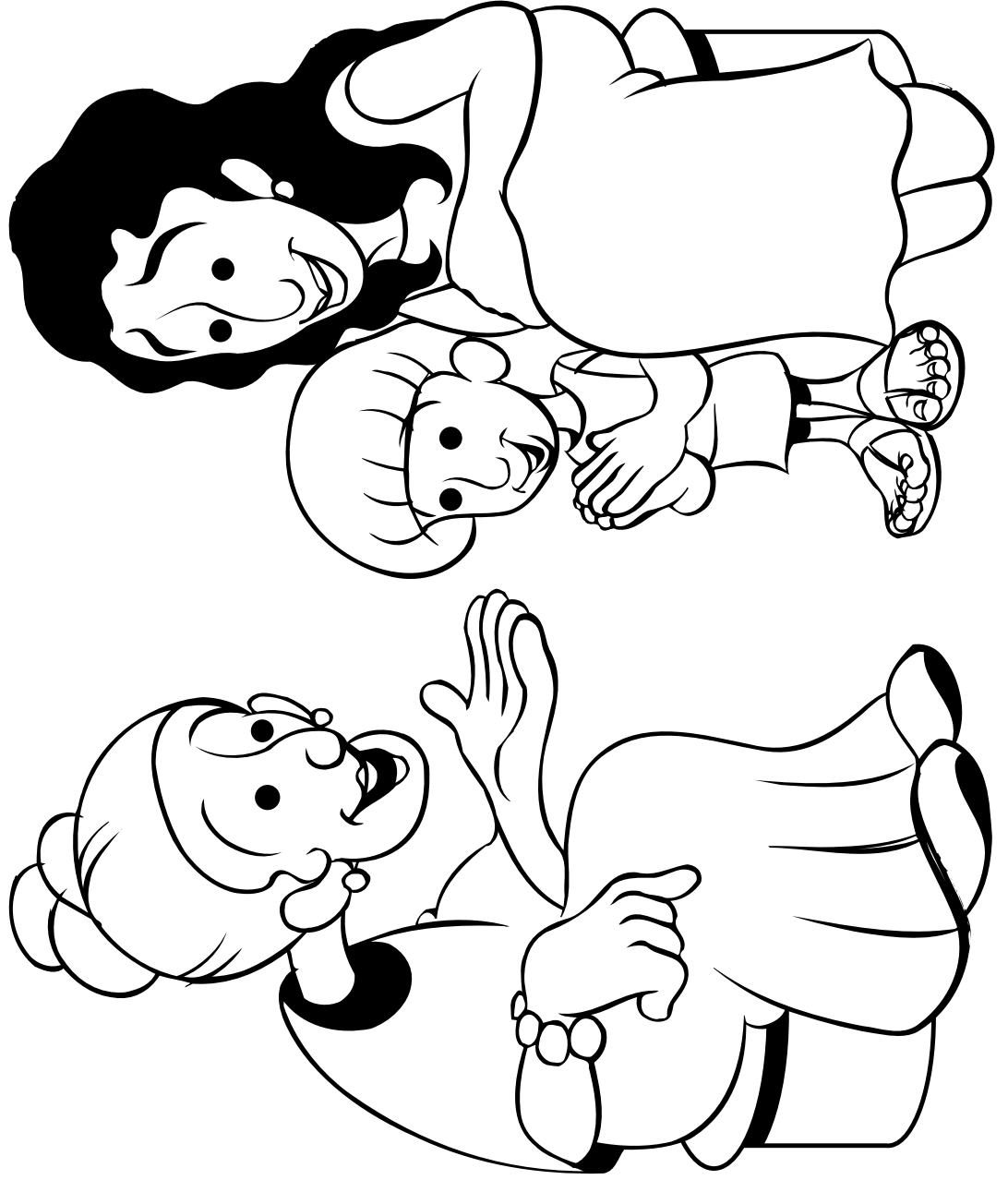



R  
e  
p  
r  
o  
d  
u  
c  
t  
i  
o  
n

Lydia  
said. . .

Welcome to  
my house.

text boxes

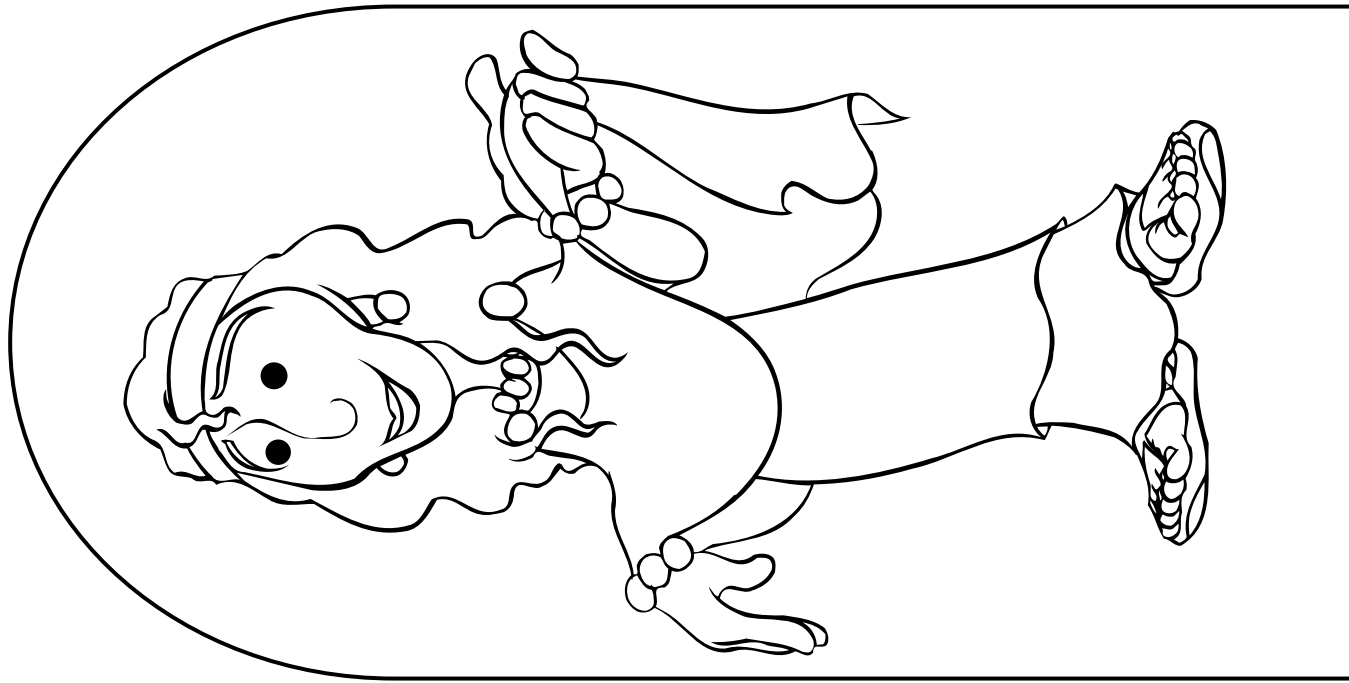

Lydia figure

