

# Peter in Jail

## Peter Goes Lesson 3

### Lesson Objectives

- The children will list three friends to pray for.
- The children will answer, "Peter," when asked, "Who were the disciples praying for?"
- The children will pray for one another.

### Bible Story Text

Acts 12:1-19

### Bible Truth

Peter obeyed God.  
(Acts 5:29)

### Lesson Plan

Greeting and Registration

Preclass Activity: Preclass Centers

Welcome and Singing

Centers:

Bible Story: Peter's Dilemma

Life Application: Share the Good News

Craft: Peter Puppet

NOTE: Be sure to allow sufficient time for a snack.



# Peter in Jail

## Preclass Centers

As the children arrive, guide them to a preclass center. Have no more than six children at each center.

### Materials

Use the materials previously selected for this unit's preclass centers.

### Preparation

1. Be sure to check the condition of the materials selected for this unit's preclass centers prior to set up. Replace any broken toys, or puzzles with missing pieces as necessary.
2. Set up the centers before the children come into the classroom.
3. Assign a teacher to each center and have the teachers stay in those centers until the singing begins.

### Instructions

Guide the play in each center reinforcing the unit theme.

### Teacher Tips

- **IMPORTANT:** Do not allow any small toys in the classroom. First check all toys for size. You can obtain a "safety cylinder" from a pediatrician. Any object that can fit into the cylinder is too small and could cause a child to choke.
- Be involved in the group play and offer guidance as needed.
- Wear comfortable clothes suitable for sitting on the floor.
- Smile! Be childlike in heart and alert in mind.

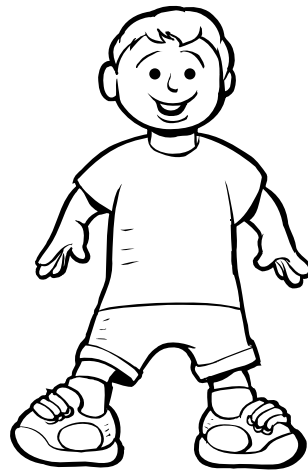

# Peter in Jail

## Peter's Dilemma

The children will learn that Peter obeyed God by telling others about Jesus. They will hear how God took care of Peter when he prayed.

### Bible Story Text

Acts 12:1-19

### Materials

*For the teacher:*

- Bible
- 1 shoebox
- 1 piece of poster board, 6" x 18"
- ruler
- glue
- markers
- scissors
- utility knife
- 1 brown paper lunch-sized bag
- black yarn for hair and a beard

*Reproducible Pages:*

- Page A, 1 copy for the teacher
- Page B, 1 copy for the teacher

### Preparation

1. Create a Peter hand puppet from the paper bag by drawing a face and gluing yarn on for hair and a beard.
2. Create a Shoebox Scene as follows:
  - A. Cut out and color the pictures from the copies of Reproducible Pages A and B.
  - B. Cut a 6" x 18" piece of poster board.
  - C. Glue the pictures to the piece of poster board from left to right in order.
  - D. Cut a slit on each side of the box so that the poster board can slide through. See Figure A.

### Freedom

Have the children sit in a circle with you. Open the Bible and place the Peter puppet on your hand. *This is Peter. Can you say Peter?*

*Peter was a very special man of God. The Bible says that Peter used to spend time with Jesus. He learned a lot from watching Jesus and being with him. He was very strong! Put up your arm and flex your muscles. Have the children imitate you. Peter loved God very much. When you love God, do you obey him? Yes! Peter obeyed God! Peter obeyed God and taught many people how to love Jesus and how to be a disciple.*

Do the "Bible Fingerplay" from the Unit 23 Song Sheet.

*Now I am going to have Peter tell you his amazing story, and remember, his story is true because it is from the Bible.*

Have the Peter puppet tell his story. *One day I was out preaching as I always did, and some men came up and told me to stop preaching. "You cannot preach about Jesus anymore," they said. But do you think I stopped? No, I did not! I obeyed God, not these men. So the men put me in prison.*

Show the children the Shoebox Scene 1. *Can you see me? Where am I? Yes, I'm in prison. I was in the prison praying for God to help me to get out so that I could teach more people about God and Jesus. My friends were also praying for me to get out of prison.*

Show the children scene 2. *Can you see me now? Who else do you see? Yes, an angel! God sent an angel to get me out of prison! The angel told me to get up. So I did. But how would we get out? The prison had big doors that were locked. But God opened the doors, and the angel and I walked right out of the prison gates!*

*When I got out of the prison I went to my friends' house. Show them scene 3. My friends were all still there praying for me. While they were praying for God to get me out of prison, I was outside knocking at the door! Do you think they were happy to see me? Do you think I was happy to see them? Yes! We hugged each other, and we thanked God for answering our prayers!*

Have the Peter puppet give a hug to each of the children. Then pray. *Dear God, thank you for saving Peter. Thank you for always watching over us and taking care of us. Help us to love you and obey you like Peter did. Help us to pray for our friends.*

NOTE: Save the Peter puppet and the shoebox scenes for the Unit 23 Lesson 4, Bible Story.



# Peter in Jail

## Peter Goes

### Lesson 3

#### Conclusion

Ask the children the following questions as a review:

- Who obeyed God and preached about Jesus? (Peter)
- Where did the men put Peter? (in prison)
- What did Peter do in prison? (he prayed)

- What did Peter's friends do while he was in prison? (they prayed for him)
- Did God help Peter? (yes)
- What did God do to help Peter? (sent an angel to get him out of prison)
- What did Peter and his friends do? (they hugged and thanked God)

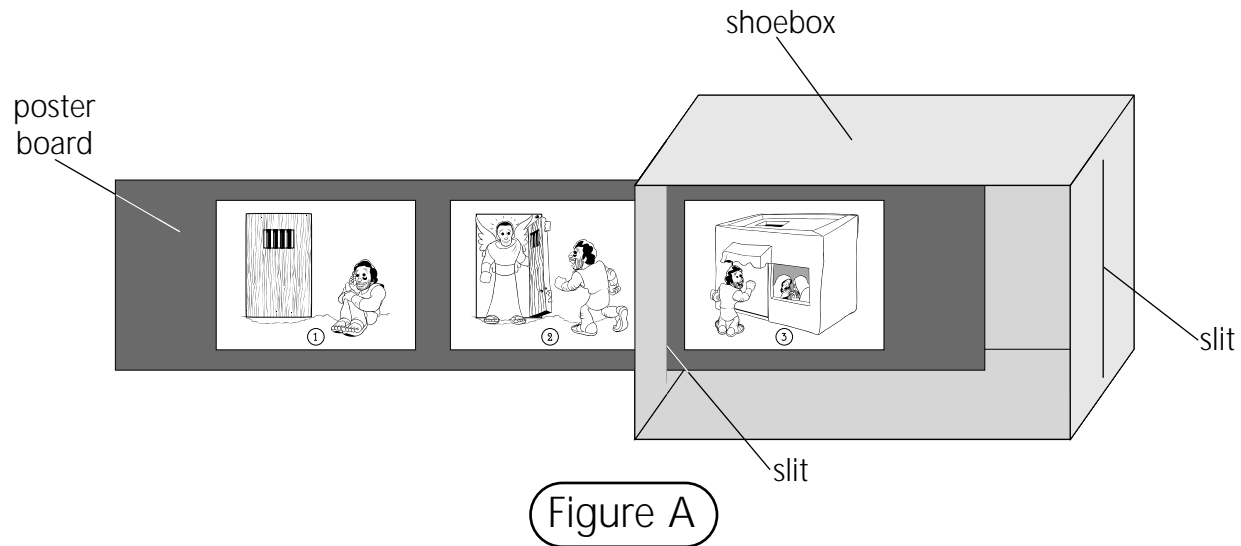

Figure A

# Peter in Jail

## Share the Good News

The children will learn to be helpful to their parents when their parents are sharing their faith.

### Bible Truth

Peter obeyed God.  
(Acts 5:29)

### Materials

*For the teacher:*

- Bible
- felt board
- poster board
- markers or crayons
- glue stick
- scissors
- tape
- laminate (optional)

*Reproducible Pages:*

- Page C, 1 copy for the teacher

### Preparation

1. Glue the copy of Reproducible Page C to poster board.
2. Cut out and color the figures.
3. Before the children arrive, place a rolled piece of tape on the back of each figure.
4. Familiarize yourself with the story.

### Instructions

Show the children each felt board figure, and remind the children of their names. *Do you remember this family? This is the mommy. This is the brother. Do you remember his name? David! This is his sister. Do you remember her name? Her name is Lesli. This is the baby. She is growing! Now she can walk and talk. Do you remember her name? Her name is Sara!*

Sing "My Own Loving Family" from the Unit 23 Song Sheet.

Place David, Lesli, Sara and Mommy on the felt board.

At the grocery store, *David and Lesli helped Mommy push the grocery cart up to the cash register. It was full of groceries! They were excited because Mommy had let them each pick out one thing. David chose his favorite cookies. He couldn't wait to get*

*home so he could eat one of those cookies! Lesli chose her favorite cereal. She could not wait to get home and eat some cereal! They both hoped Mommy would hurry in the grocery line.*

Place the woman on the felt board. *A lady was standing with them in the line. She and Mommy started talking.*

*"Hurry, Mommy!" thought David.*

*"Hurry, Mommy!" thought Lesli.*

*But Mommy didn't hurry.*

*"Mommy, let's go," David said, in a whining voice. "Baby Sara is tired, and so am I."*

*"Mommy, I am hungry," Lesli said, pulling on Mommy's arm.*

*"Let's go now."*

*Baby Sara's crying got louder and louder. Mommy quickly gave the lady an invitation to church and they left the store. Take the woman off the felt board.*

*When they got home David and Lesli sat down to eat their cookies and cereal.*

*"We need to talk first," Mommy said. "You were both very selfish at the grocery store. What was on your hearts?"*

*David said, "I wanted to get home and eat my cookies."*

*Lesli said, "I wanted to get home and eat my cereal."*

*"Do you know why I was talking to the lady at the grocery store?" Mommy asked.*

*"I saw you invite her to church," said Lesli.*

*"Yes, I was trying to invite her to church," said Mommy, "but you both interrupted me. Remember in your Bible Story that Jesus told the disciples to teach others about Jesus and help them to become Christians? If Jesus were a little boy, what do you think he would do while waiting for his mommy in the grocery store?"*

*"I think he would be happy while his mommy invited someone to church," David said. "Maybe he would even give her the invitation himself."*

*"I think he would play with his baby sister, so she would be happy while their mommy was talking to her friend," Lesli said, "because he would want to help his mommy's new friend to go to heaven."*

*"Would he whine?" asked Mommy.*

*"No," they said. "Would he complain about being hungry?" asked Mommy. "No," they said.*



# Peter in Jail

*"Let's say a prayer together," said Mommy. "David, you start, then Lesli, then me."*

*"Dear God, help me to be like Jesus and love people. Help me to be helpful when my mommy is inviting friends to church," David said.*

*"Dear God, help me to be patient and wait to eat my treats, and help me to play with Baby Sara when Mommy is talking," Lesli said.*

*"Dear God, please help us to love people like Jesus and Peter did, so we can help more people to become Christians," said Mommy. Thank you for our food. In Jesus' name we pray. Amen." They all hugged. David and Lesli said, "We are sorry, Mommy!" Mommy gave them a big smile and said, "I forgive you. Now, Let's have a snack!"*

NOTE: Save the felt board figures for the Unit 23 Lesson 4, Life Application.

## Bible Truth Activity

*What are David and Lesli going to do the next time they are out with their mommy or daddy? What are you going to do the next time you are out with your mommy or daddy? Our Bible Truth is "Peter obeyed God." Can you say that? Peter obeyed God. Peter loved other people, and he told them about Jesus so that they could become Christians. That's what God wants us to do. He wants us to obey him and tell others about Jesus just like David and Lesli's mommy did.*

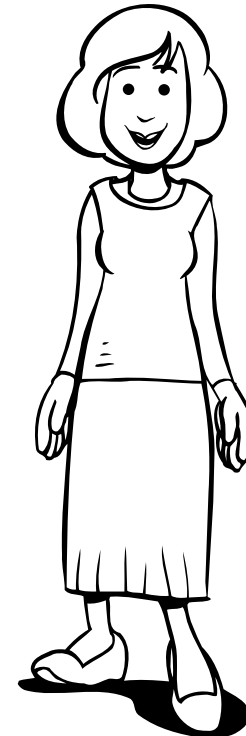
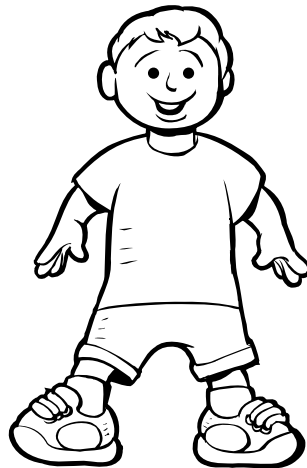

## Conclusion

*Let's talk to God. Dear God, please help us to be like Jesus and Peter and to tell other people about you. Please help us to be happy and helpful when our parents are talking to other grown-ups or inviting them to church.*

*Who are you going to tell about Bible class today? What are you going to tell them?*

## Teacher Tips

- Shorten the story as needed for 2's.
- Read through the story before class and collect any props that you think would be helpful.
- Laminate the felt board figures to make them last longer.

# Craft

## Peter in Jail

### Peter Puppet

The children will make a Peter hand puppet to remind them that Peter preached about Jesus.

#### Materials

*For each child:*

- 1 brown paper lunch-sized bag
- markers or crayons
- glue stick
- 18 pieces of yarn, 3"

*For the teacher:*

- scissors
- marker
- fabric scraps (optional)

*Reproducible Pages:*

- Page D, 1 copy for each child

#### Preparation

1. Cut out the Peter face from the copies of Reproducible Page D.
2. Cut the face in half on the solid line.
3. Cut eighteen 3" pieces of yarn for each child.
4. Make a model of the craft following the instructions.

#### Instructions

1. Show the children the model of the craft. Have the Peter puppet introduce himself to each child and give each child a hug. *We are going to make a Peter puppet for you to take home. He will help you to remember to talk to your friends about Jesus and invite them to Bible class.*
2. Give each child a brown paper bag and help them to glue the top of the head to the flap of the bag as shown in Figure A.  
NOTE: Help each child to line up the bottom of the face with the bottom edge of the flap on the bag.

3. Give each child the bottom of the head and have them glue it to the body of the bag, just under the top of the head below the flap. See Figure B.
4. Give each child eighteen pieces of yarn to glue onto Peter's head as hair and a beard.
5. Have the children color their puppet.
6. Write each child's name on their craft.

#### Conclusion

Have the children put the puppets on their hands. Talk to them and ask them questions. *Who are you? (Peter) Do you love Jesus? What do you do to show Jesus that you love him? (preach, teach others about him, invite people to church and Bible class) What did Peter tell others?*

Sing "Jesus Loves the Little Children" from the Unit 23 Song Sheet.

#### Teacher Tips

- Cut pieces of fabric for the children to glue on as Peter's clothes.

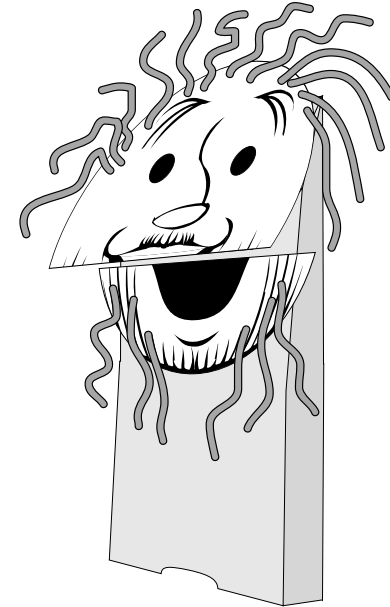

craft

# Peter in Jail

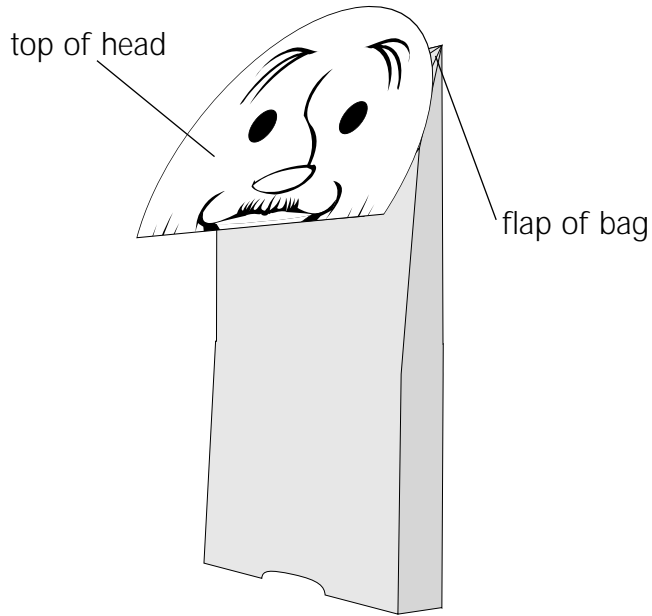

Figure A

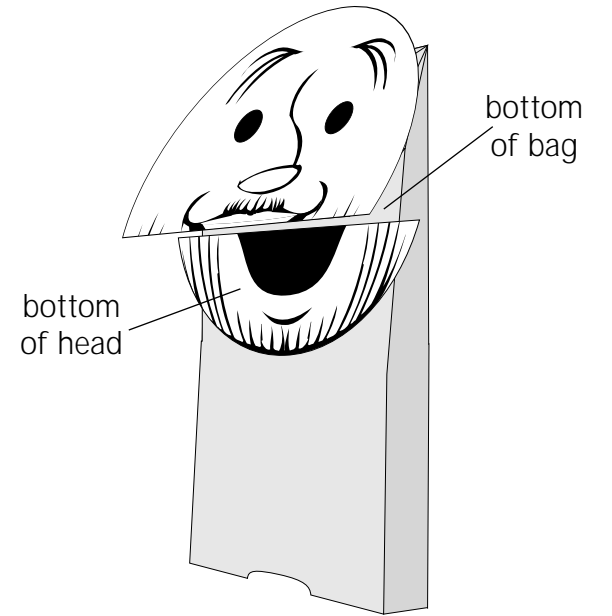
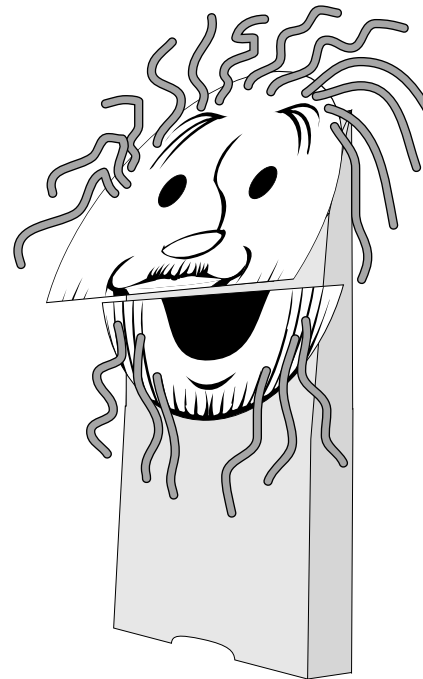

Figure B



Finished Craft







# Peter in Jail

# Peter Goes

Lesson 3

## Lesson Objectives

- The children will list three friends to pray for.
- The children will answer, "Peter," when asked, "Who were the disciples praying for?"
- The children will pray for one another.

## Bible Story Text

Acts 12:1-19

## Bible Truth

Peter obeyed God.  
(Acts 5:29)

## Preclass Centers

As the children arrive, guide them to a pre-class center. Have no more than six children at each center.

### Materials

Use the materials previously selected for this unit's preclass centers.



## Lesson Plan

Greeting and Registration

Preclass Activity: Preclass Centers

Welcome and Singing

Centers:

Life Application: Prayer Circle

Bible Story: Peter's Dilemma

Craft: Prayer Chain

NOTE: Be sure to allow sufficient time for a snack.

## Preparation

1. Be sure to check the condition of the materials selected for this unit's preclass centers prior to set up. Replace any broken toys, or puzzles with missing pieces as necessary.
2. Set up the centers before the children come into the classroom.
3. Assign a teacher to each center and have the teachers stay in those centers until the singing begins.

## Instructions

Guide the play in each center reinforcing the unit theme.

## Teacher Tips

- **IMPORTANT:** Do not allow any small toys in the classroom. First check all toys for size. You can obtain a "safety cylinder" from a pediatrician. Any object that can fit into the cylinder is too small and could cause a child to choke.
- Be involved in the group play and offer guidance as needed.
- Wear comfortable clothes suitable for sitting on the floor.
- Smile! Be childlike in heart and alert in mind.

## Prayer Circle

The children will sing a song and play a game to remind them to always pray for one another.

### Bible Truth

Peter obeyed God.  
(Acts 5:29)

### Materials

*For each child:*

- construction paper, a different color for each child in the small group

*For the teacher:*

- Bible
- scissors
- strong tape
- laminate or clear contact paper

*Reproducible Pages:*

- Page E, 1 copy for the teacher

### Preparation

1. Cut out the circle stencil from the copy of Reproducible Page E.
2. Trace and cut out one circle from each piece of construction paper.
3. Laminate the circles.
4. Before the children arrive, tape each circle to the ground in the Center area, forming a large circle.

### Instructions

1. Welcome the children to the group and have each child choose a circle to stand on.
2. Ask each child to tell the group what color they are standing on.
3. Have each child sit or lie on top of their circle so that it is covered and you can not see what color it is. *Erica, are you sitting on the orange circle? No. How about Shannon? Are you sitting on the orange circle? Yes, Shannon is on the orange circle! Shannon, stand up on your circle. Shannon gets to say a friend's name and guess what color she is sitting on.* Help the child to choose another child and guess what color that child is sitting on.

# Peter in Jail

## Peter Goes Lesson 3

4. Continue until all of the children are standing.
5. Have the children hold hands and walk slowly around the circle singing the "Prayer Circle Song" from the Unit 23 Song Sheet. At the end of the song have all of the children sit on a circle.
6. Choose a child to pray.
7. *We are sitting down to pray. What else can we do while we are praying? We can kneel down.* Show the children how to kneel on their circles. Say a short one-sentence prayer they can repeat. *(Dear God, we love you!) We can stand up and hold hands.* Have all of the children stand up and hold hands. Say a short one-sentence prayer they can repeat. *(Thank you for our friends and our teachers.) Let's stand up and sing our song again.* Have the children hold hands and sing the "Prayer Circle Song" again.
8. Sit down at the end of the song.

NOTE: Save the circles for the Unit 23 Lesson 4, Life Application.

### Bible Truth Activity

Open the Bible. *The Bible is God's word. In the Bible, we read about Peter. The Bible says Peter obeyed God. Can you say that with me? "Peter obeyed God." Who wants to be like Peter and obey God?*

*What did Peter's friends do for him when he was in jail? They prayed for him!*

### Conclusion

*Let's pray to God. Dear God, help us to be like Peter and to obey you. Help us to pray for our friends.*

*Who are you going to tell about Bible class today? What are you going to tell them?*

### Teacher Tips

- Repeat the song and have other children pray if there is time.
- For younger two's, hold a small circle of each color in your hand to help the children guess the colors.

## Peter's Dilemma

The children will learn that Peter obeyed God by telling others about Jesus. They will hear how God took care of Peter when he prayed.

### Bible Story Text

Acts 12:1-19

### Materials

*For the teacher:*

- Bible
- 1 shoebox
- 1 piece of poster board, 6" x 18"
- ruler
- glue
- markers
- scissors
- utility knife
- 1 brown paper lunch-sized bag
- black yarn for hair and a beard

*Reproducible Pages:*

- Page A, 1 copy for the teacher
- Page B, 1 copy for the teacher

### Preparation

1. Create a Peter hand puppet from the paper bag by drawing a face and gluing yarn on for hair and a beard.
2. Create a Shoebox Scene as follows:
  - A. Cut out and color the pictures from the copies of Reproducible Pages A and B.
  - B. Cut a 6" x 18" piece of poster board.
  - C. Glue the pictures to the piece of poster board from left to right in order.
  - D. Cut a slit on each side of the box so that the poster board can slide through. See Figure A.

### Freedom

Have the children sit in a circle with you. Open the Bible and place the Peter puppet on your hand. *This is Peter. Can you say Peter?*

## Peter in Jail

## Peter Goes Lesson 3

*Peter was a very special man of God. The Bible says that Peter used to spend time with Jesus. He learned a lot from watching Jesus and being with him. He was very strong! Put up your arm and flex your muscles. Have the children imitate you. Peter loved God very much. When you love God, do you obey him? Yes! Peter obeyed God! Peter obeyed God and taught many people how to love Jesus and how to be a disciple.*

Do the "Bible Fingerplay" from the Unit 23 Song Sheet.

*Now I am going to have Peter tell you his amazing story, and remember, his story is true because it is from the Bible.*

Have the Peter puppet tell his story. *One day I was out preaching as I always did, and some men came up and told me to stop preaching. "You cannot preach about Jesus anymore," they said. But do you think I stopped? No, I did not! I obeyed God, not these men. So the men put me in prison.*

Show the children the Shoebox Scene 1. *Can you see me? Where am I? Yes, I'm in prison. I was in the prison praying for God to help me to get out so that I could teach more people about God and Jesus. My friends were also praying for me to get out of prison.*

Show the children scene 2. *Can you see me now? Who else do you see? Yes, an angel! God sent an angel to get me out of prison! The angel told me to get up. So I did. But how would we get out? The prison had big doors that were locked. But God opened the doors, and the angel and I walked right out of the prison gates!*

*When I got out of the prison I went to my friends' house. Show them scene 3. My friends were all still there praying for me. While they were praying for God to get me out of prison, I was outside knocking at the door! Do you think they were happy to see me? Do you think I was happy to see them? Yes! We hugged each other, and we thanked God for answering our prayers!*

Have the Peter puppet give a hug to each of the children. Then pray. *Dear God, thank you for saving Peter. Thank you for always watching over us and taking care of us. Help us to love you and obey you like Peter did. Help us to pray for our friends.*

NOTE: Save the Peter puppet and the shoebox scenes for the Unit 23 Lesson 4, Bible Story.

# Peter in Jail

## Peter Goes Lesson 3

### Conclusion

Ask the children the following questions as a review:

- Who obeyed God and preached about Jesus? (Peter)
- Where did the men put Peter? (in prison)
- What did Peter do in prison? (he prayed)

- What did Peter's friends do while he was in prison? (they prayed for him)
- Did God help Peter? (yes)
- What did God do to help Peter? (sent an angel to get him out of prison)
- What did Peter and his friends do? (they hugged and thanked God)

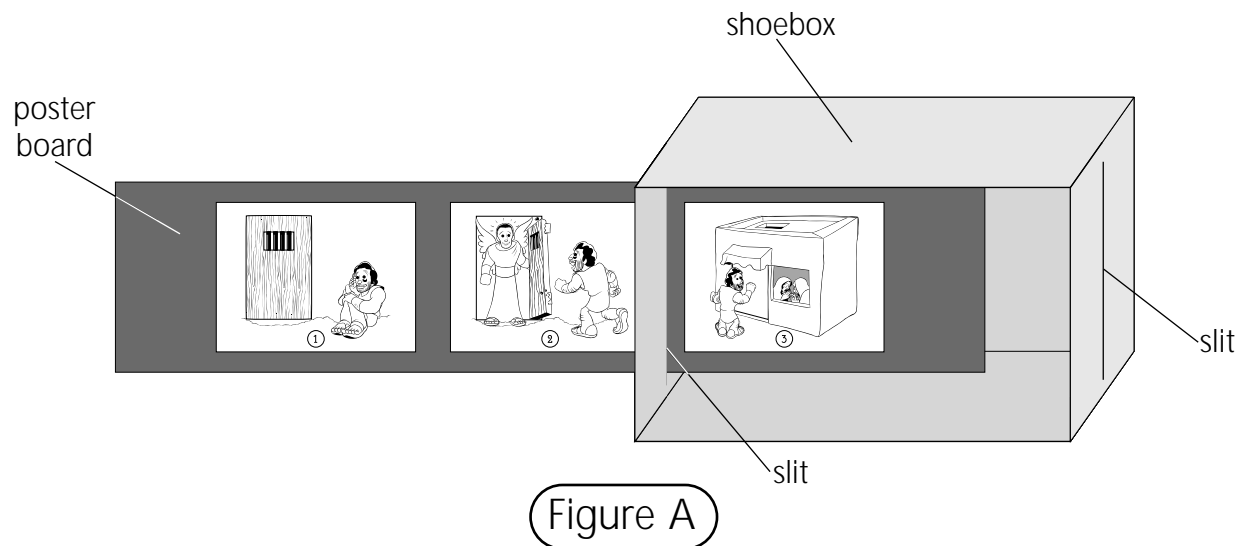

C  
r  
a  
f  
t

## Prayer Chain

The children will make a paper chain to remind them to pray for their friends.

### Materials

*For each child:*

- 5 pieces of different colored construction paper, 2" x 12"
- crayons

*For the teacher:*

- scissors
- ruler
- glue stick
- tape
- black marker

*Reproducible Pages:*

- Page F, 1 copy for each child

### Preparation

1. Cut out the labels from the copies of Reproducible Page F.
2. Cut five 2" x 12" strips of different colored construction paper for each child.
3. Glue one label to each strip of construction paper.
4. Make a model of the craft following the instructions.

### Instructions

1. Show the children the model of the craft. *Look at my prayer chain. This chain says "Pray for My Friends." This chain is to remind me to pray for my friends. Let's make a chain for you to take home so you can remember to pray for your friends.*
2. Give each child a strip that says "Pray." Have them color it.
3. While the children are coloring, help each child to bend the strip into a circle and then tape the ends together for them.
4. Give each child a strip that says "For" and have them color it.
5. Help the children to loop the second strip through the first strip and tape it. See Figure A.
6. Repeat this step with the three remaining strips.
7. When you give the children the final strip, ask them to name three friends that they want to pray for. Write the name of each friend in the space provided on the strip.
8. Write the children's names on their chains.

### Conclusion

Let each child tell the group the names of the friends that he is going to pray for.

### Teacher Tips

- Stack several sheets together to cut many strips at the same time.

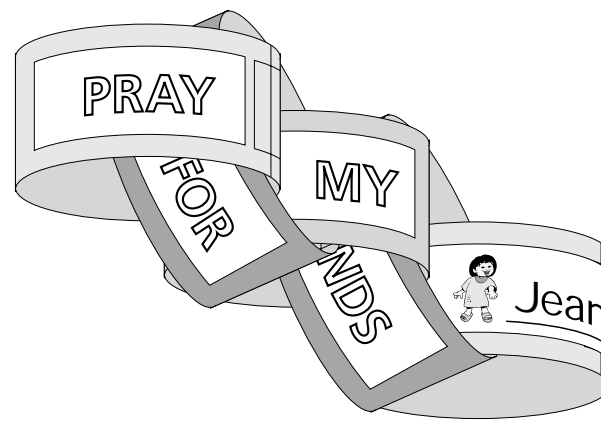

C  
r  
a  
f  
t

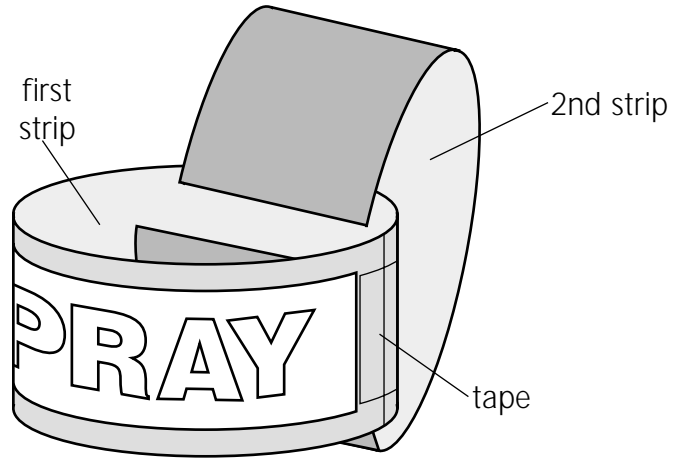
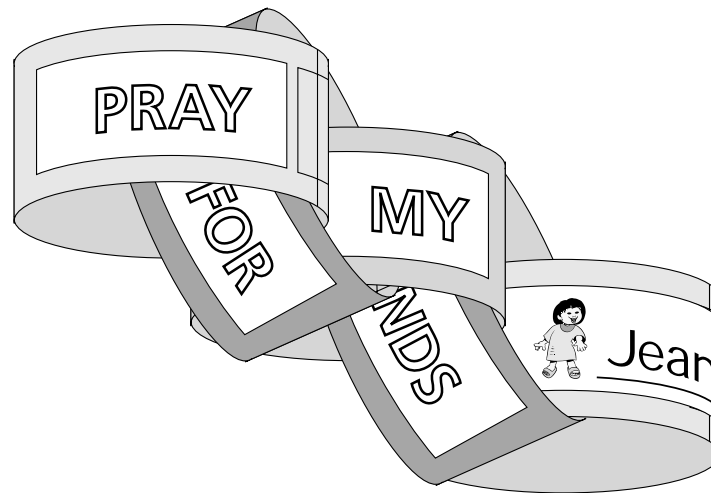

Figure A



Finished Craft





e-b-c-d-o-r-p-e R

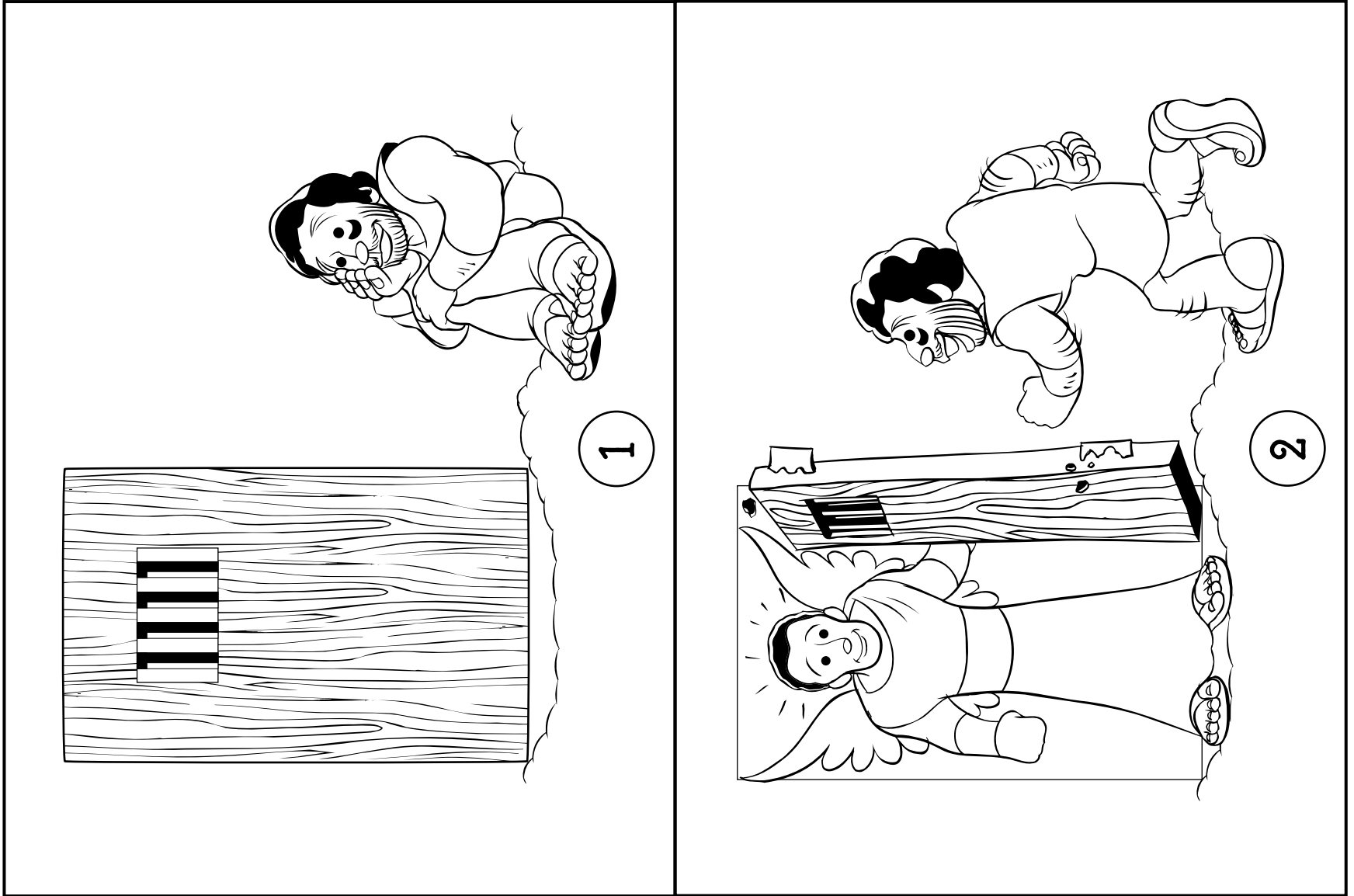



R  
e  
p  
r  
e  
s  
e  
n  
t  
e  
d

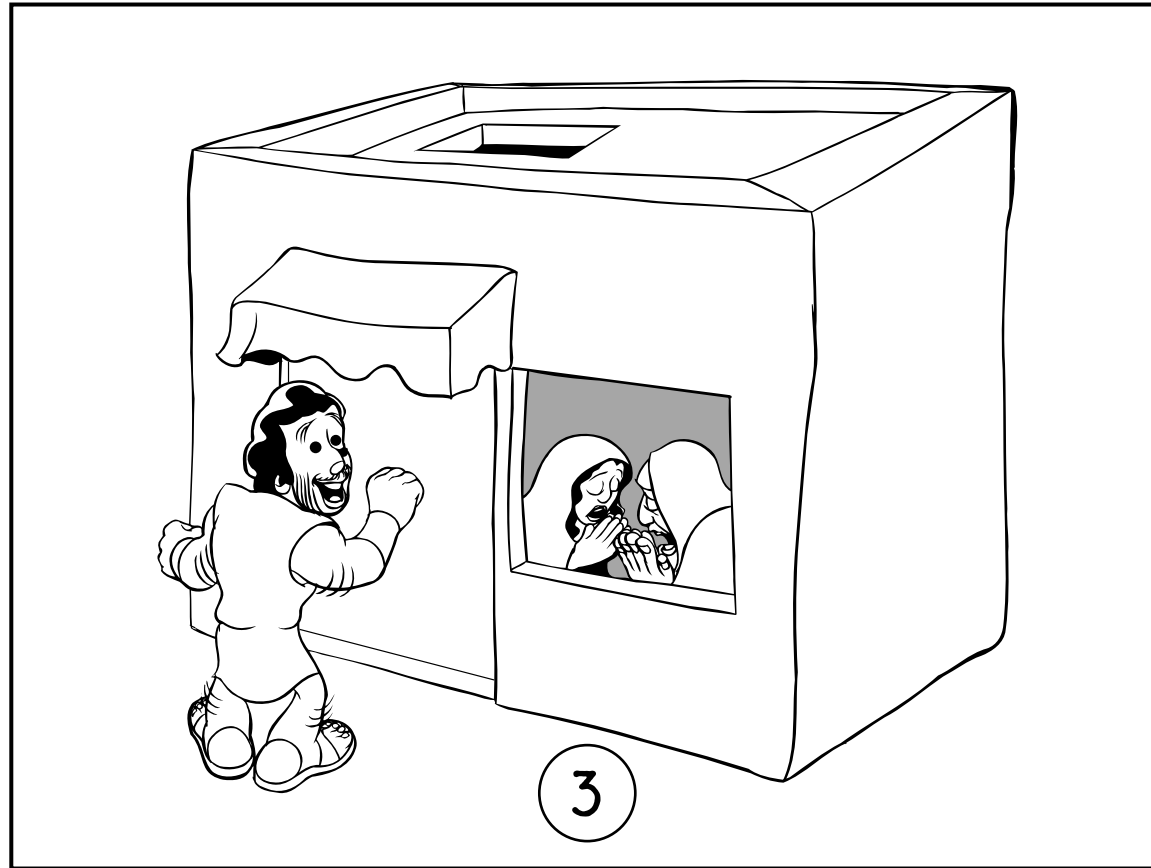





R  
e  
p  
r  
o  
d  
u  
c  
i  
o  
n



woman

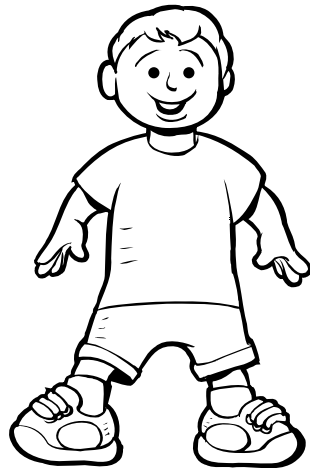

David



Lesli

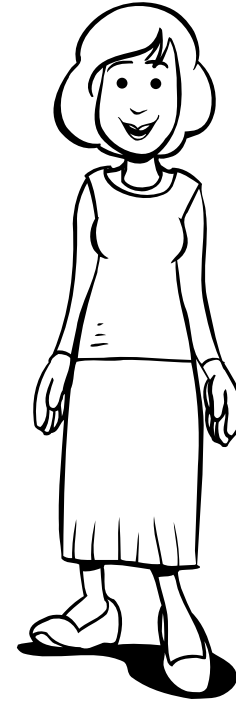

Mommy



toddler Sara





R  
e  
p  
r  
o  
d  
u  
c  
t  
i  
o  
n

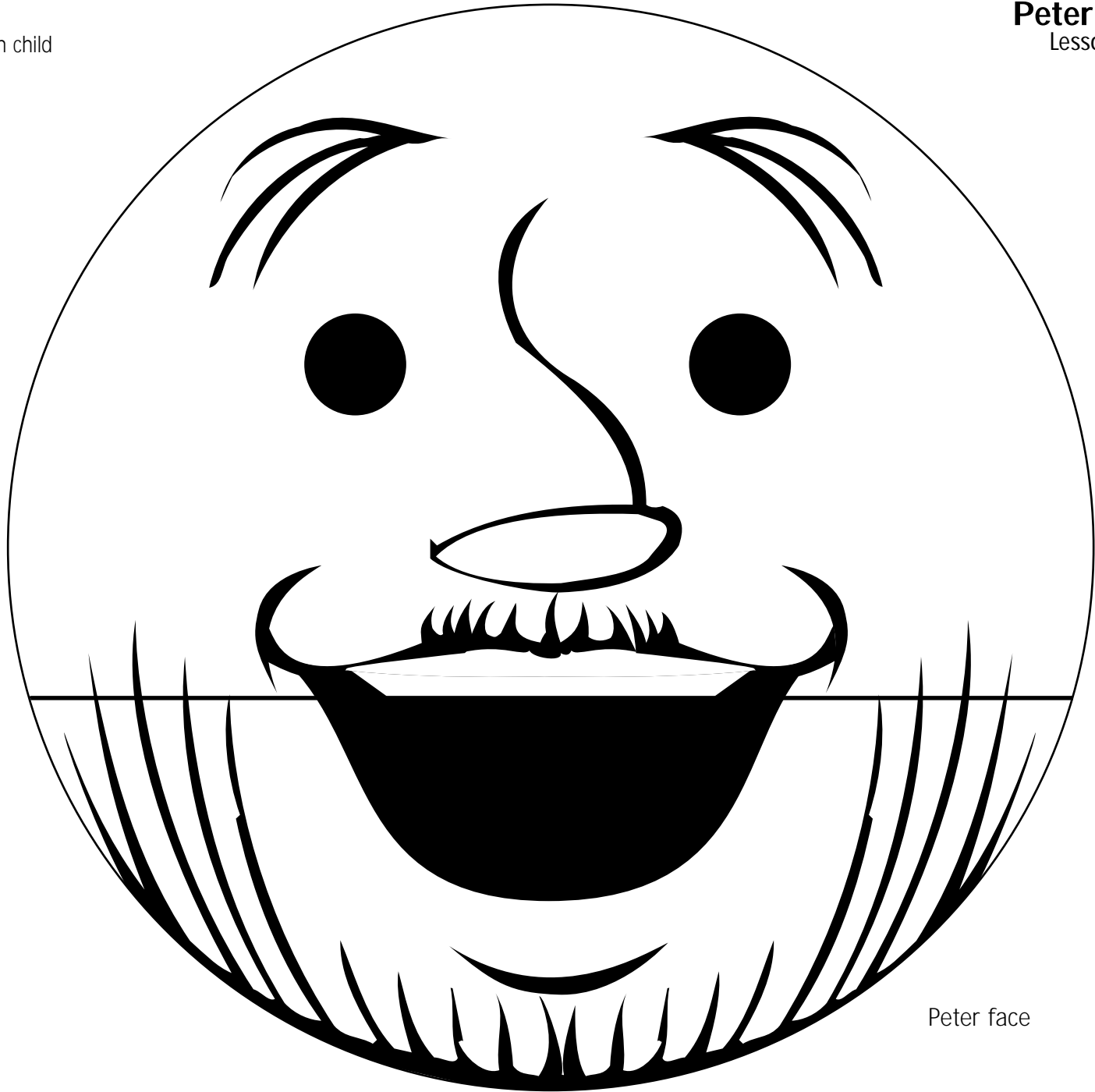

Peter face





R  
e  
p  
r  
e  
s  
e  
n  
t  
a  
t  
i  
o  
n

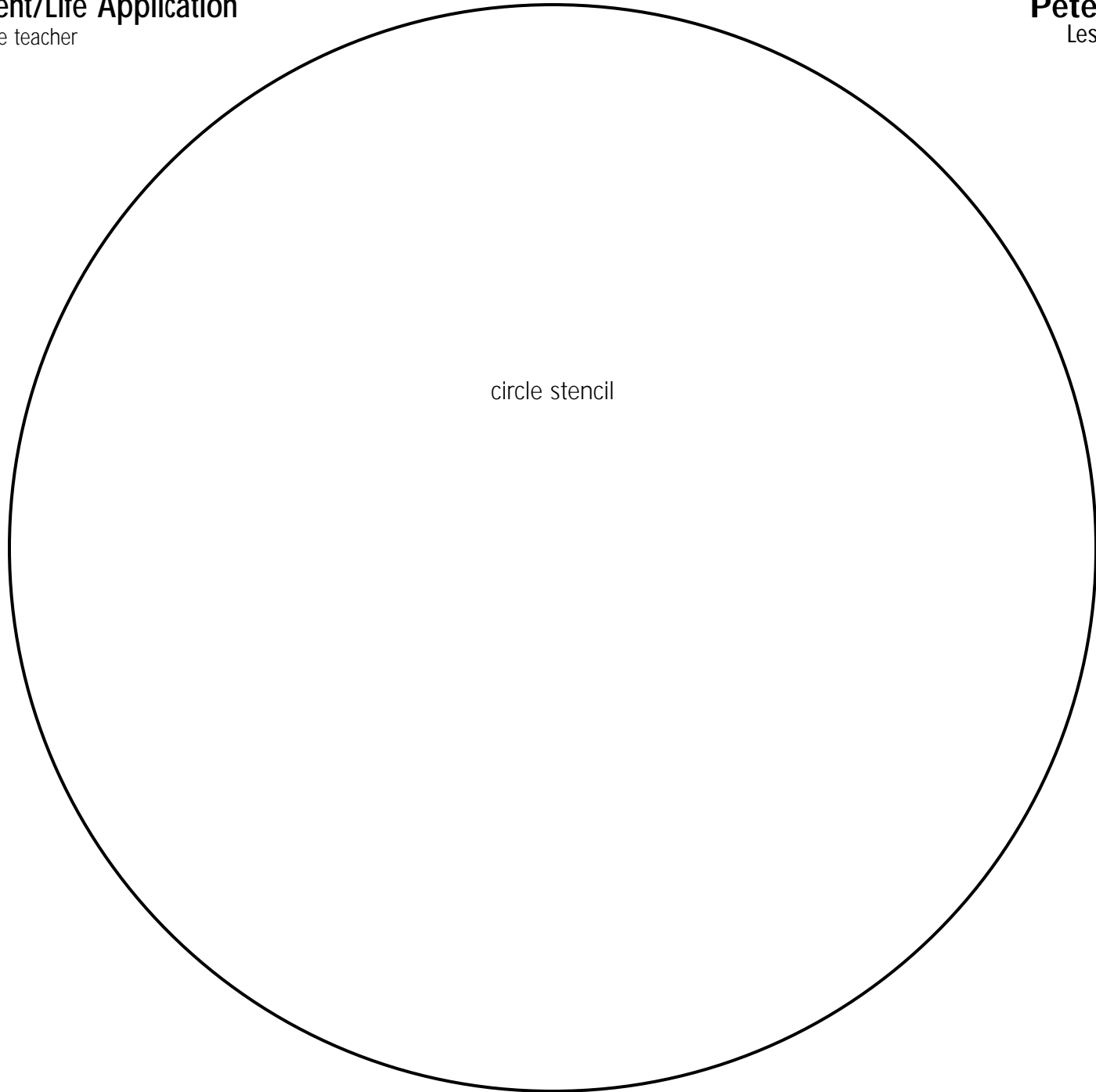

circle stencil





R  
e  
p  
r  
o  
d  
u  
c  
t  
i  
o  
n

PRAY

FOR

MY

FRIENDS



\_\_\_\_\_



\_\_\_\_\_



\_\_\_\_\_

