

# Peter and Dorcas

## Peter Goes Lesson 2

### Lesson Objectives

- The children will say, "Peter obeyed God."
- The children will answer, "Dorcas," when asked, "Who made clothes for her friends?"
- The children will help to make a gift food basket and will talk about ways to help others.

### Bible Story Text

Acts 9:36, 39

### Bible Truth

Peter obeyed God.  
(Acts 5:29)

### Lesson Plan

Greeting and Registration

Preclass Activity: Preclass Centers

Welcome and Singing

Centers:

Bible Story: Peter Tells Dorcas

Life Application: Getting Dressed

Craft: Sewing Basket

NOTE: Be sure to allow sufficient time for a snack.



# Peter and Dorcas

## Preclass Centers

As the children arrive, guide them to a preclass center. Have no more than six children at each center.

### Materials

Use the materials previously selected for this unit's preclass centers.

### Preparation

1. Be sure to check the condition of the materials selected for this unit's preclass centers prior to set up. Replace any broken toys, or puzzles with missing pieces as necessary.
2. Set up the centers before the children come into the classroom.
3. Assign a teacher to each center and have the teachers stay in those centers until the singing begins.



### Instructions

Guide the play in each center reinforcing the unit theme.

### Teacher Tips

- **IMPORTANT:** Do not allow any small toys in the classroom. First check all toys for size. You can obtain a "safety cylinder" from a pediatrician. Any object that can fit into the cylinder is too small and could cause a child to choke.
- Be involved in the group play and offer guidance as needed.
- Wear comfortable clothes suitable for sitting on the floor.
- Smile! Be childlike in heart and alert in mind.

# Peter and Dorcas

## Peter Tells Dorcas

The children will learn that Peter obeyed God by telling Dorcas about Jesus.

### Bible Story Text

Acts 9:36, 39

### Materials

For the teacher:

- Bible
- felt board
- felt board figures from the Unit 23 Lesson 1, Bible Story
- lacing cards from the Unit 23 Lesson 1, Bible Story

### Preparation

1. Familiarize yourself with the story.
2. Place a piece of rolled up tape on the back of each figure.

### Dorcas

Place Peter on the felt board. Have the children sit in a circle around you. *Come sit down with me! I have a great Bible Story to tell you! Does anyone know who this man is? Point to the Peter figure on the felt board. This is Peter. Can you say Peter?*

*Peter was a very special man of God. Open the Bible. The Bible says, Peter used to walk around with Jesus. He learned a lot from watching Jesus and being with him. He was very strong! Put up your arms and flex your muscles. Have the children imitate you. Peter loved God very much. When you love God, do you obey him? Yes! Peter obeyed God! Peter obeyed God by teaching many people how to love Jesus and how to be disciples.*

Do the "Bible Fingerplay" together from the Unit 23 Song Sheet. *This is what Peter did! When he preached, he told them: (Sing the first verse of "Jesus Loves the Little Children" from the Unit 23 Song Sheet.)*

*It says in the Bible that Peter went to see a disciple named Dorcas (Acts 9:39). Put Dorcas on the felt board. Can you say Dorcas? Dorcas was a very special lady and she obeyed God, too! Do you know what she did that was so special? She sewed clothes for people! Do you think somebody had to sew your clothes that you have on right now? Yes! Look at my shirt, do you see these little tiny lines on my shirt? These are called stitches. Look at your*

*clothes. Do you see any stitches on your clothes? Have the children feel the stitches on their clothes.*

*Some of Dorcas' friends only had old clothes to wear. Put the old shirt on the felt board. Dorcas made beautiful new clothes for them! Replace the old shirt with the new shirt. That is how she obeyed God. By loving and helping other people. Did you know that God wants us to take care of our friends who need help? God wanted Dorcas to help her friends, so they could have nice clothes to wear!*

*Would you like to help sew some clothes like Dorcas did? I have some clothes right here that need to be sewn and I need some help. Give each child a poster board shirt. Show them how to lace the shoelaces through the holes. This is how Dorcas sewed her clothes! Isn't this fun?*

### Conclusion

Ask the children the following questions as a review:

- Who obeyed God? (Peter and Dorcas)
- Who went to see Dorcas? (Peter)
- Who made clothes for her friends who needed help? (Dorcas)
- Were her friends happy with their new clothes? (Yes)
- Is God happy when we obey? (Yes)
- Who do you want to help? What do you want to do to help others?

### Teacher Tips

- Be sure to practice the story beforehand so that you don't have to read it to the children.
- Bring in a shirt that clearly shows stitching to show to the children.

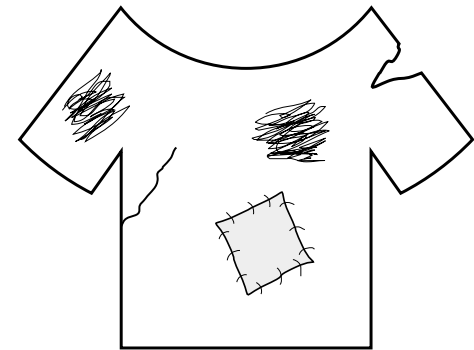

# Peter and Dorcas

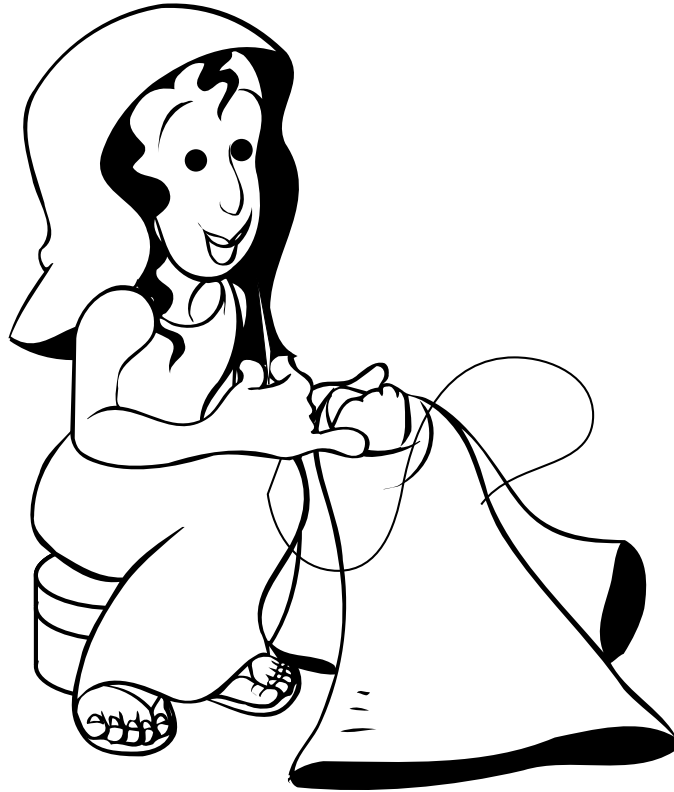

# Peter and Dorcas

## Getting Dressed

The children will help to dress a large stuffed animal to reinforce the lesson that Dorcas helped to clothe the poor.

### Bible Truth

Peter obeyed God.  
(Acts 5:29)

### Materials

*For the teacher:*

- Bible
- stuffed animal or doll made for preschool children that has a zipper, snap, Velcro, etc., on the clothing

### Preparation

1. Familiarize yourself with the activity.
2. Learn "This Is the Way" from the Unit 23 Song Sheet.

### Instructions

Open the Bible. *In our Bible Story we are learning about a woman named Dorcas who made clothes for her friends. Today we are going to help a friend who needs help getting dressed.*

Show the children the doll. *This friend needs help getting dressed. Let's see what he needs.* Demonstrate all the different buttons and snaps. As you demonstrate each activity sing a corresponding verse of the song "This Is the Way" from the Unit 23 Song Sheet.

Repeat the song as each child has a turn buttoning, snapping and zipping the doll.

### Bible Truth Activity

*Let's all sit down now, and open the Bible. Open the Bible. The Bible is God's word. In the Bible, we read about Dorcas who made clothes for her friends. Can you say "Dorcas"? In the Bible we read about Peter, who was Dorcas' friend. Can you say "Peter"? The Bible says Peter obeyed God and preached. Peter obeyed God. Can you say that with me? "Peter obeyed God." Who wants to be like Peter and obey God?*

### Conclusion

*Let's talk to God. Dear God, thank you for the Bible, and thank you for Dorcas and Peter. Help us to be like Dorcas in helping our friends. Help us to be like Peter and obey you.*

*Who are you going to tell about Bible class today? What are you going to tell them?*

### Teacher Tips

- To make your own doll for the activity, dress a large stuffed animal or doll in young children's clothing. Be sure the clothing includes zippers, snaps, buttons, etc.

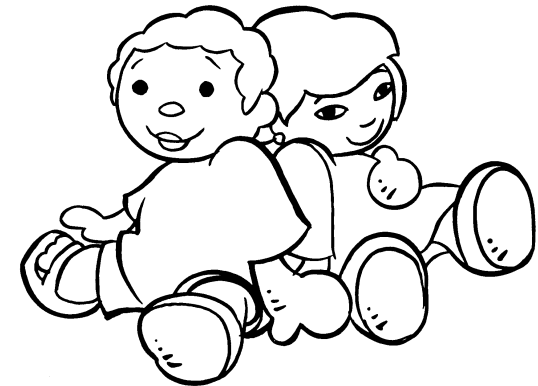

# Peter obeyed God.



# Peter and Dorcas

## Sewing Basket

The children will make a sewing basket to remind them that Dorcas sewed clothes for her friends.

### Materials

*For each child:*

- 1½ paper plates
- 1 piece of construction paper, 1½" x 6"
- 2 pieces of yarn, 24"
- ½ pipe cleaner
- crayons

*For the teacher:*

- utility knife or scissors
- ruler
- glue
- hole punch
- tape
- marker
- pencil
- stapler

*Reproducible Pages:*

- Page A, 1 copy for the teacher
- Page B, 1 copy for every 4 children

### Preparation

1. Cut out the button and spool stencils from the copy of Reproducible Page A.
2. Cut out the pictures and text boxes from the copies of Reproducible Page B.
3. Make a "basket" for each child as follows:
  - A. Cut a paper plate in half.
  - B. Cut a handle on a whole paper plate. See Figure A.
  - C. Place the half plate on top of the whole plate forming a pocket and staple them together. See Figure B.
  - D. Glue a picture and text box onto the basket.
4. Trace and cut out one spool and three buttons for each child from construction paper.
5. Punch two holes on each button as indicated on the stencil.
6. Cut each pipe cleaner in half and bend each half to look like a "needle." See Figure C.

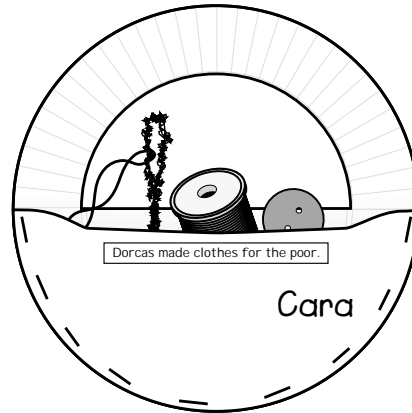

7. Cut two, 24" pieces of yarn for each child and tape one piece of yarn to the center of each spool.
8. Thread a piece of yarn through each needle and tie it.
9. Make a model of the craft following the instructions.

### Instructions

1. Show the children the model of the craft. Take out each item and explain what they are. Remind the children of Dorcas who sewed clothes for the poor.
2. Give each child a basket and have them color the picture on the front.
3. Give each child a spool and help them to gently wrap the yarn around it. Have them put it in the basket.
4. Give each child three buttons to add to their basket.
5. Give each child a pipe cleaner needle and some thread to add to their basket.
6. Have the children color and decorate their baskets.
7. Write the children's names on their baskets.

### Conclusion

Let each child show you one item in his sewing basket. Sing the second verse of the "Helping Mitt Song" from the Unit 23 Song Sheet. Use the craft as a prop.

### Teacher Tips

- Use silver pipe cleaners for the needles.
- Talk with the children about each item as they add them to the baskets.
- Bring additional materials for the children to decorate their baskets with.

# Peter and Dorcas

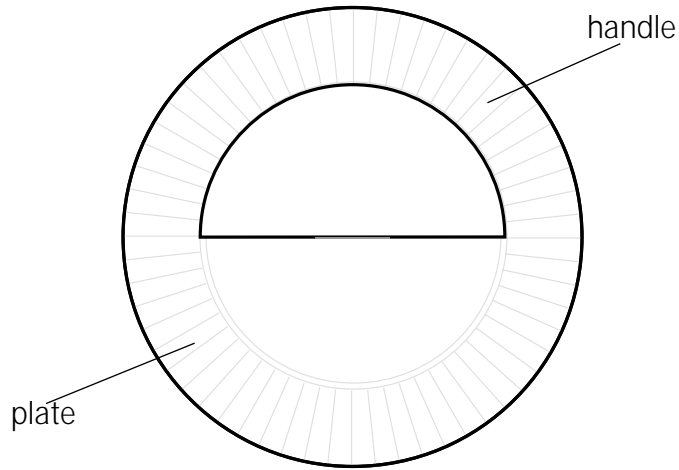

Figure A

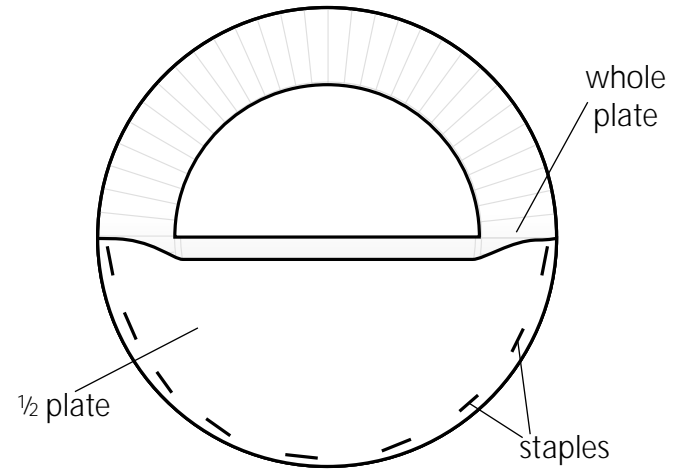

Figure B

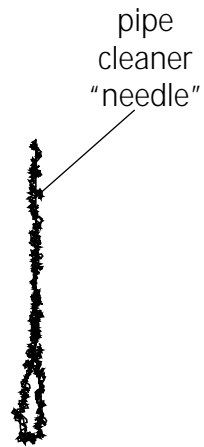
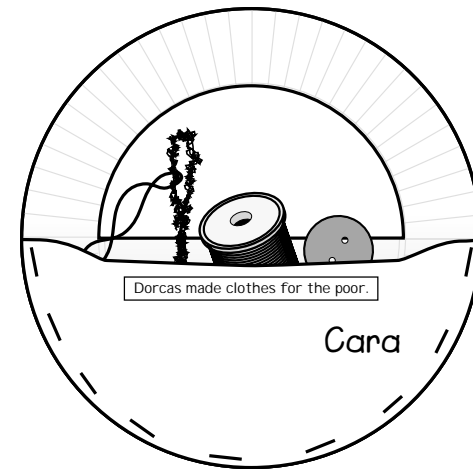

Figure C



Finished Craft







# Peter and Dorcas

## Peter Goes

Lesson 2

### Lesson Objectives

- The children will say, "Peter obeyed God."
- The children will answer, "Dorcas," when asked, "Who made clothes for her friends?"
- The children will help to make a gift food basket and will talk about ways to help others.

### Bible Story Text

Acts 9:36, 39

### Bible Truth

Peter obeyed God.  
(Acts 5:29)

### Preclass Centers

As the children arrive, guide them to a pre-class center. Have no more than six children at each center.

#### Materials

Use the materials previously selected for this unit's preclass centers.

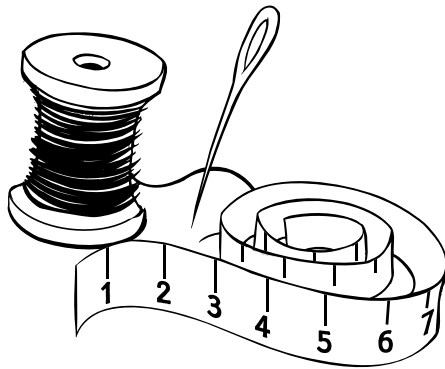

### Preparation

1. Be sure to check the condition of the materials selected for this unit's preclass centers prior to set up. Replace any broken toys, or puzzles with missing pieces as necessary.
2. Set up the centers before the children come into the classroom.
3. Assign a teacher to each center and have the teachers stay in those centers until the singing begins.

### Instructions

Guide the play in each center reinforcing the unit theme.

### Lesson Plan

Greeting and Registration

Preclass Activity: Preclass Centers

Welcome and Singing

Centers:

Life Application: Helping Hands

Bible Story: Peter Tells Dorcas

Craft: Helper's Mitt

NOTE: Be sure to allow sufficient time for a snack.

### Teacher Tips

- **IMPORTANT:** Do not allow any small toys in the classroom. First check all toys for size. You can obtain a "safety cylinder" from a pediatrician. Any object that can fit into the cylinder is too small and could cause a child to choke.
- Be involved in the group play and offer guidance as needed.
- Wear comfortable clothes suitable for sitting on the floor.
- Smile! Be childlike in heart and alert in mind.

Life

Application



## Helping Hands

The children will help to make a food basket and a card to encourage someone who needs help.

### Bible Truth

Peter obeyed God.  
(Acts 5:29)

### Materials

For the teacher:

- Bible
- card from the Unit 23 Lesson 1, Life Application
- 1 large basket (to be given away as a gift)
- tissue paper
- ribbon
- non-perishable food brought by parents

### Preparation

1. As the children are dropped off, collect the non-perishable food items from the parents that you requested the last class.
2. Arrange to have the person whom you want to give the basket to visit at the end of the class so the children can present the basket to them.

### Instructions

1. Open the Bible. *Who was the woman in our Bible Story who made clothes to help her friends? Yes, it was Dorcas! Today we are going to help some of our friends who are in need.* Show the children the card from the Unit 23 Lesson 1, Life Application and remind them of whom you are going to give the basket and card to.
2. Have each child put a piece of tissue paper into the basket and have them help you to wrap the ribbon around the handle. As you work, explain to the children that you are making the basket look pretty. Ask questions that help the children to understand that decorating the basket will help the person to feel special.
3. Give each child a non-perishable item.
4. Have each child tell the group what the item is and whether or not they like to eat it or use it. Then have them place the item in the basket. NOTE: Help the children to identify the item that they have.

### Bible Truth Activity

*Let's all sit down now, and open the Bible. Open the Bible. The Bible is God's word. In the Bible, we read about Dorcas who made clothes for her friends. Can you say "Dorcas"? In the Bible we read about Peter, who was Dorcas' friend. Can you say "Peter"? The Bible says Peter obeyed God and preached. Peter obeyed God. Can you say that with me? "Peter obeyed God." Who wants to be like Peter and obey God?*

### Conclusion

*Let's talk to God. Dear God, thank you for the Bible, and thank you for Dorcas and Peter. Help us to take care of our friends like Dorcas did. Help us to be like Peter and obey you. In Jesus' name we pray. Amen.*

*Who are you going to tell about Bible class today? What are you going to tell them?*

### Teacher Tips

- As the children arrive, be sure to ask the parents for the non-perishable food items you requested from the Unit 23 Lesson 1, Life Application.
- Bring extra non-perishable food items for those who may have forgotten them.



## Peter Tells Dorcas

The children will learn that Peter obeyed God by telling Dorcas about Jesus.

### Bible Story Text

Acts 9:36, 39

### Materials

For the teacher:

- Bible
- felt board
- felt board figures from the Unit 23 Lesson 1, Bible Story
- lacing cards from the Unit 23 Lesson 1, Bible Story

### Preparation

Familiarize yourself with the story.

### Dorcas

*Does anyone know who this man is?* Point to the Peter figure on the felt board. *This is Peter. Can you say Peter?*

*Peter was a very special man of God. Open the Bible. The Bible says, Peter used to walk around with Jesus. He learned a lot from watching Jesus and being with him. He was very strong!* Put up your arms and flex your muscles. Have the children imitate you. *Peter loved God very much. When you love God, do you obey him? Yes! Peter obeyed God! Peter obeyed God by teaching many people how to love Jesus and how to be disciples.*

Do the "Bible Fingerplay" together from the Unit 23 Song Sheet. *This is what Peter did! When he preached, he told them:* (Sing the first verse of "Jesus Loves the Little Children" from the Unit 23 Song Sheet.)

*It says in the Bible that Peter went to see a disciple named Dorcas (Acts 9:39). Put Dorcas on the felt board. Can you say Dorcas? Dorcas was a very special lady and she obeyed God, too! Do you know what she did that was so special? She sewed clothes for people! Do you think somebody had to sew your clothes that you have on right now? Yes! Look at my shirt, do you see these little tiny lines on my shirt? These are called stitches. Look at your clothes. Do you see any stitches on your clothes?* Have the children feel the stitches on their clothes.

*Some of Dorcas' friends only had old clothes to wear. Put the old shirt on the felt board. Dorcas made beautiful new clothes for them! Replace the old shirt with the new shirt. That is how she obeyed God. By loving and helping other people. Did you know that God wants us to take care of our friends who need help? God wanted Dorcas to help her friends, so they could have nice clothes to wear!*

*Would you like to help sew some clothes like Dorcas did? I have some clothes right here that need to be sewn and I need some help. Give each child a poster board shirt. Show them how to lace the shoelaces through the holes. This is how Dorcas sewed her clothes! Isn't this fun?*

### Conclusion

Ask the children the following questions as a review:

- Who obeyed God? (Peter and Dorcas)
- Who went to see Dorcas? (Peter)
- Who made clothes for her friends who needed help? (Dorcas)
- Were her friends happy with their new clothes? (Yes)
- Is God happy when we obey? (Yes)
- Who do you want to help? What do you want to do to help others?

### Teacher Tips

- Be sure to practice the story beforehand so that you don't have to read it to the children.
- Bring in a shirt that clearly shows stitching to show to the children.





# Craft

## Helper's Mitt

The children will make a dusting mitt so that they can be helpers at home.

### Materials

*For each child:*

- 1 piece of felt, 8" x 11"
- 1 piece of yarn, 20"
- 5 fabric scraps

*For the teacher:*

- scissors
- ruler
- tacky glue
- tape
- hole punch
- black marker

*Reproducible Pages:*

- Page C, 1 copy for the teacher

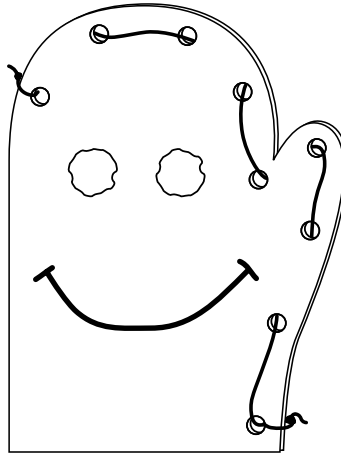

### Preparation

1. Cut out the mitt stencil from the copy of Reproducible Page C.
2. Trace and cut out one mitt for each child from felt.
3. Fold the mitt in half and punch holes around the open side of the mitt. See Figure A.
4. Draw a smile on each mitt.
5. Cut a 20" piece of yarn for each child.
6. Tie a piece of yarn onto an end hole on each mitt. Place a piece of tape around the opposite end of the yarn.
7. Cut the fabric scraps into five shapes for each child. Be sure to cut two circles for each child to use as eyes.
8. Make a model of the craft following the instructions.

### Instructions

1. Show the children the model of the craft. *Does anyone know what this is? This is a Helping Mitt. You can wear it to help your family clean your house. Do you ever help to dust the furniture? Demonstrate dusting with the mitt. Pass the mitt from child to child, letting each child put it on his hand, and then dust a little of the table or chair. Let's make one for you to take home to help at your house.*
2. Give each child a mitt and a piece of yarn. Help the children to thread the yarn through the holes in the mitt, sewing it together.
3. Tie the yarn to the end hole of the mitt and cut off any excess yarn.
4. Give each child two circles for eyes. Place two small dots of glue on the mitt above the smile where the eyes should go. Help the children place the eyes on the glue.
5. Give each child three fabric shapes. Place three dots of glue on the opposite side of the mitt and have the children place one shape on each dot of glue.
6. Place a piece of tape on the back of the mitt and write the child's name on the tape.

### Conclusion

Sing the "Helping Mitt Song" from the Unit 23 Song Sheet. Use the mitts as props.

### Teacher Tips

- For a younger group, sew the mitts before class.
- Use a 3-hole punch to make the holes in the mitts.
- Briefly explain to the parents that this craft is a helping mitt so that the children can help dust the house. Tell them that the children learned about Dorcas helping her friends and that the children are being encouraged to help at home.

C  
r  
a  
f  
t

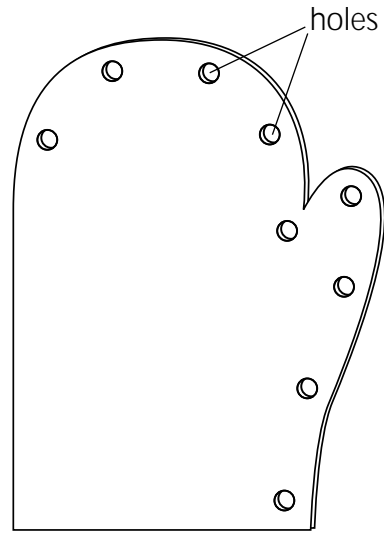
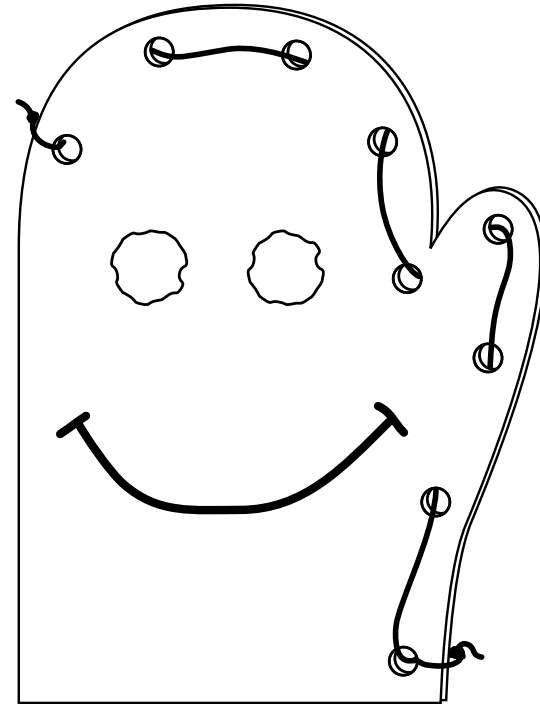

Figure A



Finished Craft





R  
e  
p  
r  
o  
d  
u  
c  
t  
i  
o  
n

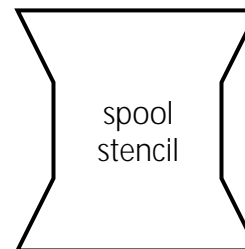
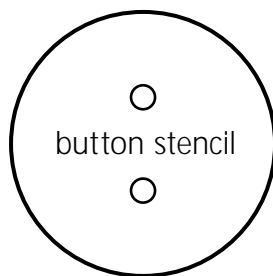

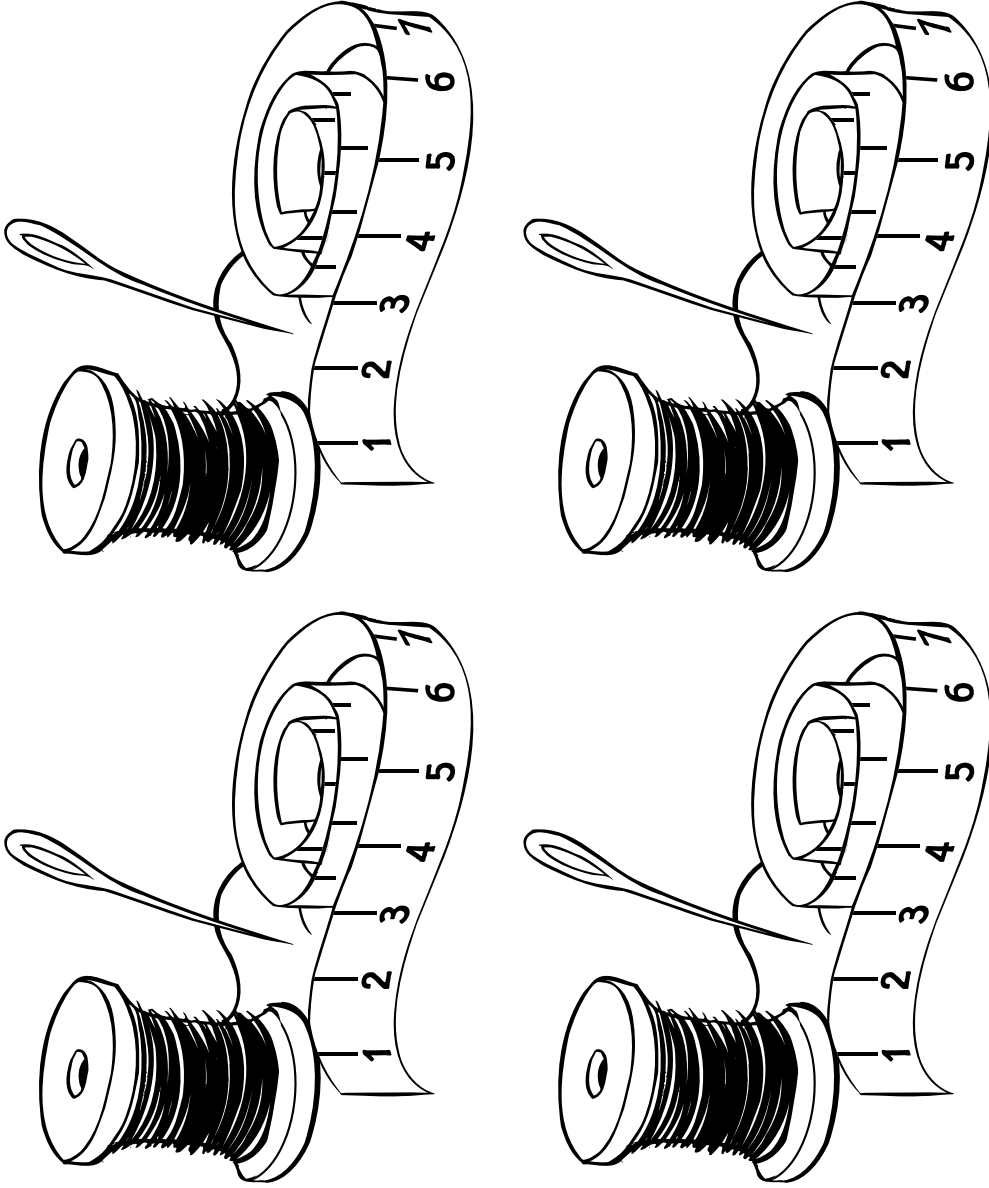

pictures

Dorcas made clothes for the poor.  
 Dorcas made clothes for the poor.  
 Dorcas made clothes for the poor.  
 Dorcas made clothes for the poor.

text boxes





R  
e  
p  
r  
o  
d  
u  
c  
e  
d  
b  
y  
e

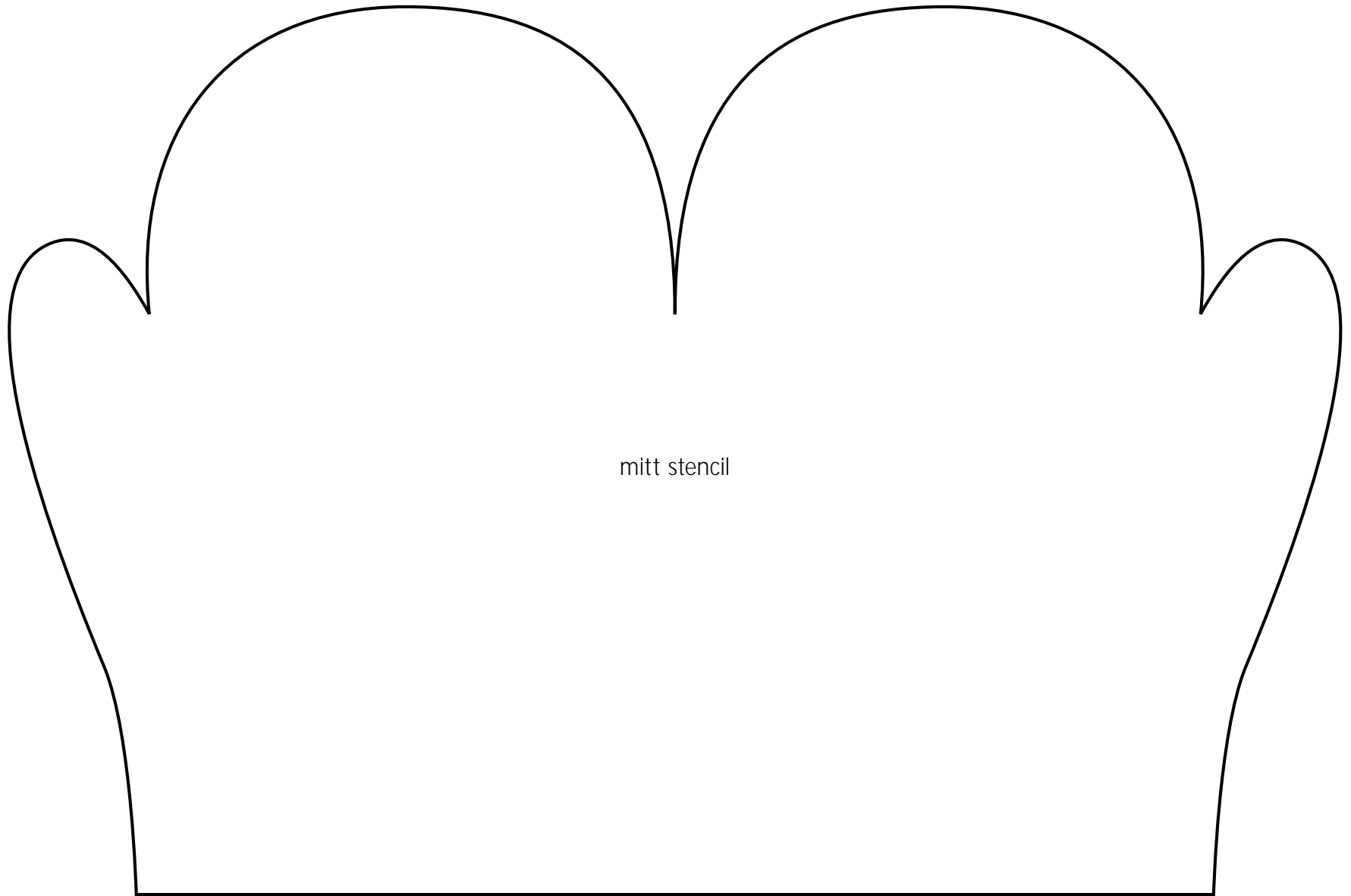

mitt stencil

