

# Philip Goes

**Go!**  
Lesson 3

## Lesson Objectives

- The children will name the Ethiopian as the man who Philip taught about Jesus.
- The children will practice sharing the Bible with each other.
- The children will state that God wants them to share the Bible with their friends.

## Bible Story Text

Acts 8:26-38

## Bible Truth

Jesus says, "Go!"  
(Matthew 28:19)

## Lesson Plan

Greeting and Registration

Preclass Activity: Preclass Centers

Welcome and Singing

Centers:

Bible Story: Philip Makes a Disciple

Life Application: Pass the Bible

Craft: In the Desert

NOTE: Be sure to allow sufficient time for a snack.



# Philip Goes

## Preclass Centers

As the children arrive, guide them to a preclass center. Have no more than six children at each center.

### Materials

Use the materials previously selected for this unit's preclass centers.

### Preparation

1. Be sure to check the condition of the materials selected for this unit's preclass centers prior to set up. Replace any broken toys, or puzzles with missing pieces as necessary.
2. Set up the centers before the children come into the classroom.
3. Assign a teacher to each center and have the teachers stay in those centers until the singing begins.

### Instructions

Guide the play in each center reinforcing the unit theme.

### Teacher Tips

- **IMPORTANT:** Do not allow any small toys in the classroom. First check all toys for size. You can obtain a "safety cylinder" from a pediatrician. Any object that can fit into the cylinder is too small and could cause a child to choke.
- Be involved in the group play and offer guidance as needed.
- Wear comfortable clothes suitable for sitting on the floor.
- Smile! Be childlike in heart and alert in mind.

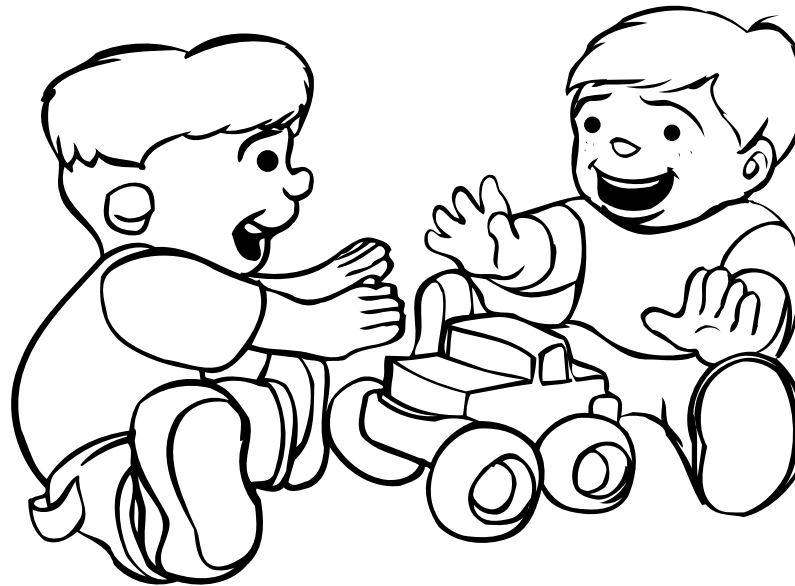

# Philip Goes

## Philip Makes a Disciple

The children will hear how Philip taught the Ethiopian to become a disciple.

### Bible Story Text

Acts 8:26-38

### Materials

For the teacher:

- Bible
- large box
- utility knife
- scissors
- blue construction paper, 4" x 4"
- tape
- markers or crayons
- 2 large craft sticks

Reproducible Pages:

- Page A, 1 copy for the teacher
- Page B, 1 copy for the teacher

### Preparation

1. Cut out and color the Philip and the Ethiopian figures and the chariot from the copies of Reproducible pages A and B.
2. Tape a craft stick to the back of each figure making it a puppet.
3. Create a puppet stage as follows:
  - A. Fold in the open flaps of a large box. See Figure A.
  - B. Place the box on its side and cut a slit along the top edge. See Figure B.
4. Glue the following to the box. See Figure C.
  - A. Cut a 4" x 4" piece of blue construction paper and glue it to the front of the box in front of the slit. This will be the water.
  - B. Glue the chariot on the opposite side of the water.
5. Practice telling the story with the stage and the puppets.

### The Ethiopian

Have all of the children sit in a circle and place the stage on your lap. *Today we are going to see a puppet show!*

Open the Bible. *The Bible says that a long time ago there was a man who had a big heart for God.* Show the Ethiopian puppet. Point to his heart. Let the children have a turn touching his heart.

*The Ethiopian was a very special man because he had a heart that wanted to love God! That means he wanted to learn as much about God as he could. Where can you learn about God? Yes, at church or in the Bible. This man was coming from church and he was reading his Bible. We do not know this man's name, but we do know that he was from the country of Ethiopia. That is why he is called the Ethiopian. Can you say that?*

*One day the Ethiopian was riding along in his chariot. Show the children the chariot. Insert the Ethiopian puppet stick through the slit in the stage behind the chariot.*

*Hi, boys and girls! Guess who I am? I am the Ethiopian! Guess what I am doing? I am riding in my chariot! Guess what else I am doing? I am reading the Bible, but I don't understand what I am reading. I wish I had someone to help me! What will I do?*

*Show the children the Philip figure. Hi, boys and girls! My name is Philip. Can you say Philip? I am a disciple, and I love to teach other people about Jesus. I'm looking for someone who loves God and wants to learn about Jesus. An angel told me I should travel down this road (Acts 8:26). Do you know anyone who would like to study the Bible with me? Let the children answer. Who? Where? Oh, there! That guy there? Do you think he will study the Bible? Do you think he wants to know about Jesus?*

*Have Philip run to the chariot with the Ethiopian inside. Hi, my name is Philip. What are you reading?*

*I am reading the Bible, but I don't understand it. Can you help me?*

*Yes! I'd love to help you understand the Bible.*

*Philip got right up inside the chariot with the Ethiopian. Insert the Philip puppet stick into the slit beside the Ethiopian. They had a Bible Study right there in the chariot! And do you think the Ethiopian wanted to love Jesus? Yes, he did! (Acts 8:27-35). And when they got to some water the Ethiopian said, "Look, here is water. Why shouldn't I be baptized?" The Bible says they stopped the chariot and got down and Philip baptized the Ethiopian (Acts 8:36-38). Have the figures get out of the chariot and go down to the water. Have them hug and rejoice together. Have all of the children clap for the Ethiopian's baptism.*

NOTE: Save the puppet stage and the puppets for the Unit 22 Lesson 4, Bible Story.



# Philip Goes

## Conclusion

Ask the following questions as a review:

- Who was riding in the chariot? (the Ethiopian)
- What was he reading? (the Bible)
- Who helped the Ethiopian learn about Jesus? (Philip)
- What should we share with our friends? (the Bible, Jesus)

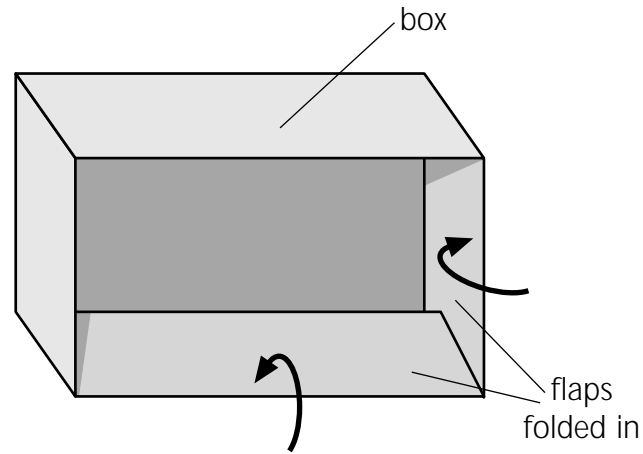

Figure A

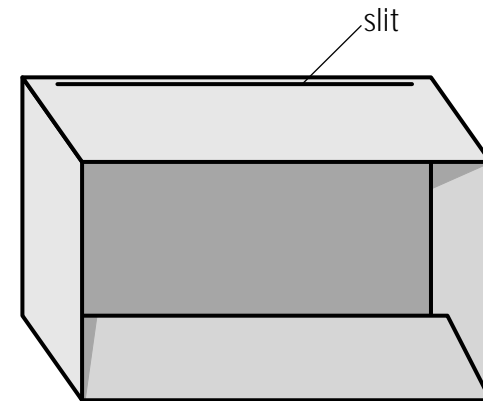

Figure B

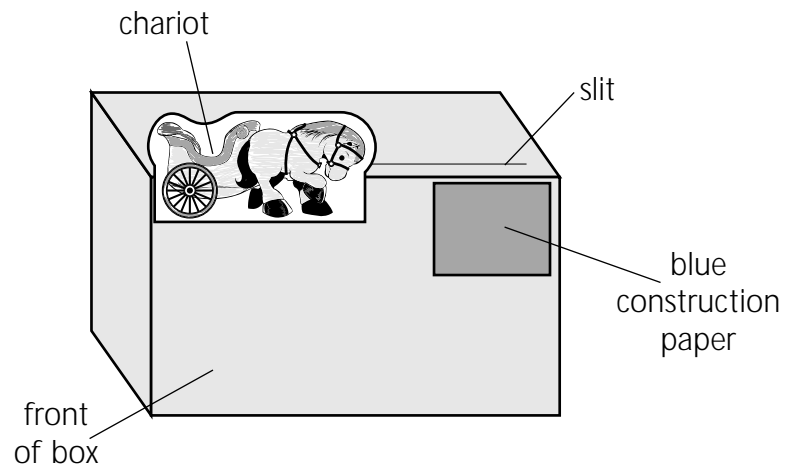

Figure C



# Philip Goes

## Pass the Bible

This activity will remind the children to share the Bible with their friends.

### Bible Truth

Jesus says, "Go!"  
(Matthew 28:19)

### Materials

*For the teacher:*

- Bible
- cassette tape player
- vocal/musical tape appropriate for children

### Preparation

1. Choose a tape which is appropriate for young children.
2. Learn the "Bible Fingerplay" from the Unit 22 Song Sheet.

### Instructions

Show the children the Bible. *Who can tell me what this is? Yes, this is the Bible! Who wrote the Bible? That's right, God did! Are the stories in the Bible real, or are they pretend? They are real! Who remembers what Jesus told the disciples to do in the Bible? He said, "Go"! What do Jesus' disciples do? Disciples "Go" where Jesus says to go. Jesus says to go and share the Bible. Today we are going to play a game about sharing the Bible.*

Sit with the children in a circle. Hold the Bible in your lap. *When the music starts, I am going to pass the Bible. When the Bible comes to you, pass it to the friend sitting next to you. When the music stops, hold on to the Bible. We will see who is holding it when the music stops.*

When you are ready, start the music. Pass the Bible to a child sitting next to you. Encourage each child to pass the Bible to the child next to them. After it has gone around the group at least once, stop the music. *Who has the Bible? Stephen does! Yeah! Stephen can learn about Jesus in the Bible. We shared the Bible with Stephen.*

Repeat the game, varying the length of the music each time. Make sure that each child has a chance to hold the Bible when the music stops.

### Bible Truth Activity

Open the Bible. *The Bible is God's Word. We obey the Bible. We obey God, and we obey Jesus when we obey the Bible. In the Bible, Jesus says, "Go." Can you say "go"? Let's all say that together. "Jesus says, 'Go!'" Bronson, will you obey Jesus and go? Juliana, will you obey Jesus and go?*

### Conclusion

*Let's talk to God. Dear God, thank you for the Bible, and thank you for Jesus. Help us to obey Jesus and to go and tell our friends about him. In Jesus' name we pray. Amen.*

*Who are you going to tell about Bible class today? What are you going to tell them?*

End the Center with the "Bible Fingerplay" from the Unit 22 Song Sheet.

### Teacher Tips

- Be sure the batteries of the cassette player work.

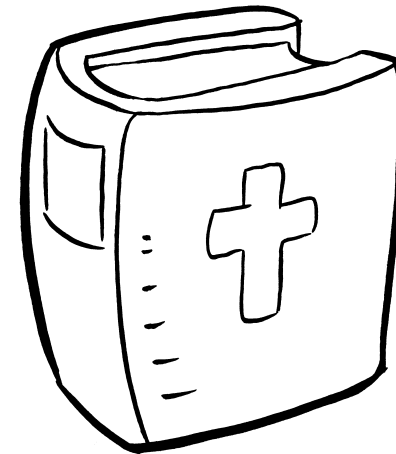

Jesus says,  
"Go!"



# Craft

## Philip Goes In the Desert

The children will make a picture of Philip and the Ethiopian to remind them that Philip taught the Ethiopian about Jesus.

### Materials

*For each child:*

- 1 piece of light-colored construction paper, 9" x 12"
- 1 piece of yellow construction paper, 2" x 2"
- 1 piece of black construction paper, 2" x 1¼"
- 1 piece of brown construction paper, 1" x 5"
- 2 pieces of green construction paper, 2" x 5"
- 1 piece of sandpaper or brown paper, 2" x 7"
- 1 piece of blue cellophane, 2" x 6"
- 1 piece of red felt, 1" x 1"
- glue stick
- crayons

*For the teacher:*

- scissors
- marker
- glue

*Reproducible Pages:*

- Page C, 1 copy for the teacher
- Page D, 1 copy for each child

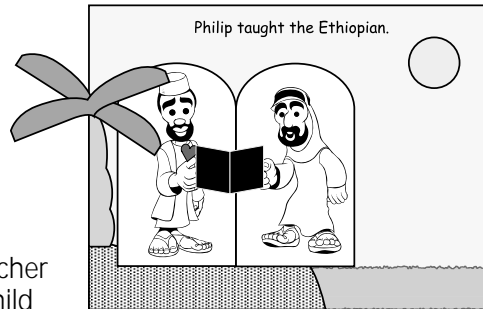

### Preparation

1. Cut out the stencils from the copy of Reproducible Page C.
2. Using the stencils, trace and cut out each of the following shapes for each child:
  - A. a heart from red felt
  - B. a sun from yellow construction paper
  - C. a tree trunk from brown construction paper
  - D. two palm fronds from green construction paper
  - E. the ground from sandpaper
  - F. water from blue cellophane (2" x 6")
  - G. a Bible from black construction paper (2" x 1¼") NOTE: Fold it in half to make a 1" x 1¼" Bible.
3. Cut out the Philip and the Ethiopian figures from the copies of Reproducible Page D.
4. On each piece of light-colored construction paper write, "Philip taught the Ethiopian."

5. Glue the following shapes onto a piece of light-colored construction paper for each child. See Figure A:
  - A. Glue the sandpaper ground on the bottom left side of the paper.
  - B. Glue the tree trunk on top of the ground on the left edge of the paper.
  - C. Glue the sun in the upper right corner of the paper.
6. Make a model of the craft following the instructions.

### Instructions

1. Show the children the model of the craft. Read the title of the page. *You are each going to make a picture of Philip and the Ethiopian so you can remember to teach your friends about God and invite them to Bible class.*
2. Give each child a sheet of construction paper and two palm fronds. Have them glue the fronds to the top of the tree.
3. Give each child a piece of cellophane to glue to the bottom right of the paper next to the ground.
4. Give each child a Philip figure and an Ethiopian figure to glue next to each other on the ground.
5. Give each child a heart to glue onto the Ethiopian.
6. Give each child a Bible to glue in between the two figures.
7. Write each child's name on his craft.

### Conclusion

Ask the following questions and have the children point to different parts of their crafts:

- Where is Philip?
- Where is the Ethiopian?
- Where is the Bible?
- Where is the Ethiopian's heart?
- Where is the Ethiopian going to get baptized?

### Teacher Tips

- For younger twos, glue more of the shapes onto the paper before class
- Draw lines on the brown trunk to make it look more like a tree trunk.

craft

# Philip Goes

Go!  
Lesson 3

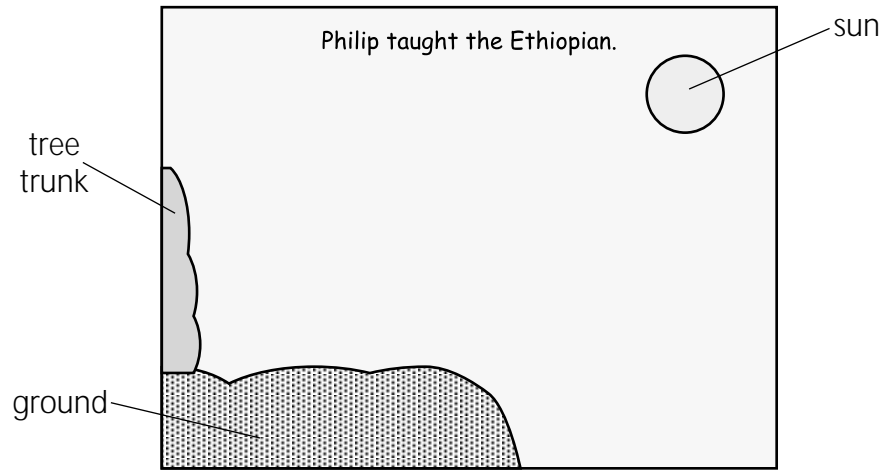
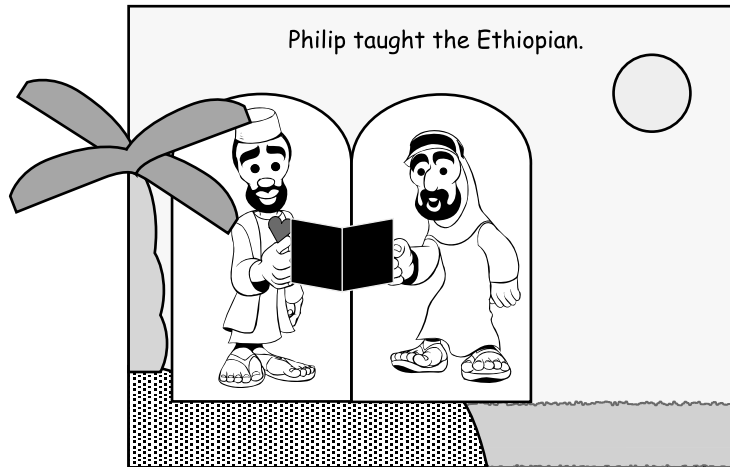

Figure A



Finished Craft







# Philip Goes

**Go!**  
Lesson 3

## Lesson Objectives

- The children will name the Ethiopian as the man who Philip taught about Jesus.
- The children will practice sharing the Bible with each other.
- The children will state that God wants them to share the Bible with their friends.

## Bible Story Text

Acts 8:26-38

## Bible Truth

Jesus says, "Go!"  
(Matthew 28:19)

## Preclass Centers

As the children arrive, guide them to a pre-class center. Have no more than six children at each center.

### Materials

Use the materials previously selected for this unit's preclass centers.

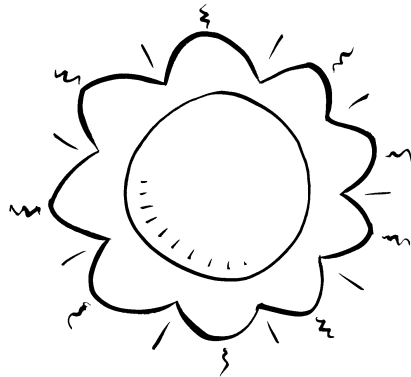

## Preparation

1. Be sure to check the condition of the materials selected for this unit's preclass centers prior to set up. Replace any broken toys, or puzzles with missing pieces as necessary.
2. Set up the centers before the children come into the classroom.
3. Assign a teacher to each center and have the teachers stay in those centers until the singing begins.

## Instructions

Guide the play in each center reinforcing the unit theme.

## Lesson Plan

Greeting and Registration

Preclass Activity: Preclass Centers

Welcome and Singing

Centers:

Life Application: Where Is He?

Bible Story: Philip Makes a Disciple

Craft: Gospel Chariot

NOTE: Be sure to allow sufficient time for a snack.

## Teacher Tips

- **IMPORTANT:** Do not allow any small toys in the classroom. First check all toys for size. You can obtain a "safety cylinder" from a pediatrician. Any object that can fit into the cylinder is too small and could cause a child to choke.
- Be involved in the group play and offer guidance as needed.
- Wear comfortable clothes suitable for sitting on the floor.
- Smile! Be childlike in heart and alert in mind.

## Where Is He?

The children will be reminded of the Ethiopian's conversion.

### Bible Truth

Jesus says, "Go!"  
(Matthew 28:19)

### Materials

*For the teacher:*

- Bible
- scissors
- crayons
- tape

*Reproducible Pages*

- Page A, 1 copy for the teacher

### Preparation

1. Cut out and color the Ethiopian figure from the copy of Reproducible Page A. NOTE: You will not need the Philip figure.
2. Put a rolled piece of tape on the back of the Ethiopian figure.

### Instructions

1. Have the children sit in a circle.
2. Show the children the Ethiopian figure. *Do you remember who this is? Yes, it's the Ethiopian. Did he love God? Yes he did. Philip told him about Jesus and he was baptized. Philip had been looking for someone to teach about Jesus and he found the Ethiopian. In our game we are going to have to find the Ethiopian too.*
3. Choose one child to sit in the middle of the circle and cover her eyes.
4. Place the Ethiopian on an arm or leg of one of the children in the circle as you sing "Jesus Loves the Little Children" from the Unit 22 Song Sheet.
5. Have the child in the middle open her eyes and find the Ethiopian.
6. Give each child a turn. As each child finds the Ethiopian tell them that now they can teach him about Jesus.

NOTE: Save the Ethiopian for the Unit 22 Lesson 4, Life Application.

# Philip Goes

### Bible Truth Activity

Open the Bible. *The Bible is God's Word. We obey the Bible. In the Bible, Jesus says, "Go!" Can you say "go"? Let's all say that together. "Jesus says, 'Go!'"*

Do the "Bible Fingerplay" from the Unit 22 Song Sheet.

### Conclusion

*Let's talk to God. Dear God, thank you for the Bible, and thank you for Jesus. Help us to be like Jesus and share the Bible with our friends.*

*Who are you going to tell about Bible class today? What are you going to tell them?*

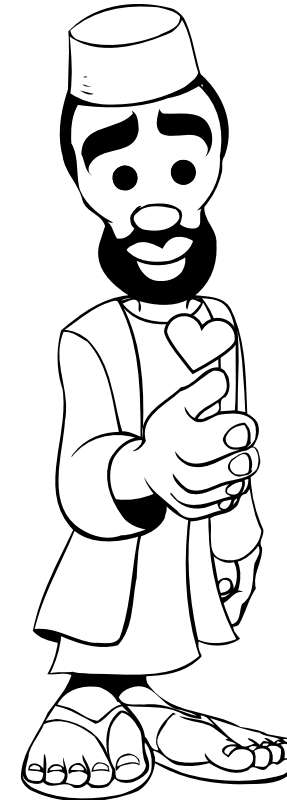

## Philip Makes a Disciple

The children will hear how Philip taught the Ethiopian to become a disciple.

### Bible Story Text

Acts 8:26-38

### Materials

*For the teacher:*

- Bible
- large box
- utility knife
- scissors
- blue construction paper, 4" x 4"
- tape
- markers or crayons
- 2 large craft sticks

*Reproducible Pages:*

- Page A, 1 copy for the teacher
- Page B, 1 copy for the teacher

### Preparation

1. Cut out and color the Philip and the Ethiopian figures and the chariot from the copies of Reproducible pages A and B.
2. Tape a craft stick to the back of each figure making it a puppet.
3. Create a puppet stage as follows:
  - A. Fold in the open flaps of the box. See Figure A.
  - B. Place the box on its side and cut a slit along the top edge. See Figure B.
4. Glue the following to the box. See Figure C.
  - A. Cut a 4" x 4" piece of blue construction paper and glue it to the front of the box in front of the slit. This will be the water.
  - B. Glue the chariot on the opposite side of the water.
5. Practice telling the story with the stage and the puppets.

### The Ethiopian

Have all of the children sit in a circle and place the stage on your lap. *Today we are going to see a puppet show!*

Open the Bible. *The Bible says that a long time ago there was a man who had a big heart for God.* Show the Ethiopian puppet. Point to his heart. Let the children have a turn touching his heart.

# Philip Goes

*The Ethiopian was a very special man because he had a heart that wanted to love God! That means he wanted to learn as much about God as he could. Where can you learn about God? Yes, at church or in the Bible. This man was coming from church and he was reading his Bible. We do not know this man's name, but we do know that he was from the country of Ethiopia. That is why he is called the Ethiopian. Can you say that?*

*One day the Ethiopian was riding along in his chariot. Show the children the chariot. Insert the Ethiopian puppet stick through the slit in the stage behind the chariot.*

*Hi, boys and girls! Guess who I am? I am the Ethiopian! Guess what I am doing? I am riding in my chariot! Guess what else I am doing? I am reading the Bible, but I don't understand what I am reading. I wish I had someone to help me! What will I do?*

*Show the children the Philip figure. Hi, boys and girls! My name is Philip. Can you say Philip? I am a disciple, and I love to teach other people about Jesus. I'm looking for someone who loves God and wants to learn about Jesus. An angel told me I should travel down this road (Acts 8:26). Do you know anyone who would like to study the Bible with me? Let the children answer. Who? Where? Oh, there! That guy there? Do you think he will study the Bible? Do you think he wants to know about Jesus?*

*Have Philip run to the chariot with the Ethiopian inside. Hi, my name is Philip. What are you reading?*

*I am reading the Bible, but I don't understand it. Can you help me?*

*Yes! I'd love to help you understand the Bible.*

*Philip got right up inside the chariot with the Ethiopian. Insert the Philip puppet stick into the slit beside the Ethiopian. They had a Bible Study right there in the chariot! And do you think the Ethiopian wanted to love Jesus? Yes, he did! (Acts 8:27-35). And when they got to some water the Ethiopian said, "Look, here is water. Why shouldn't I be baptized?" The Bible says they stopped the chariot and got down and Philip baptized the Ethiopian (Acts 8:36-38). Have the figures get out of the chariot and go down to the water. Have them hug and rejoice together. Have all of the children clap for the Ethiopian's baptism.*

NOTE: Save the puppet stage and the puppets for the Unit 22 Lesson 4, Bible Story.

## Conclusion

Ask the following questions as a review:

- Who was riding in the chariot? (the Ethiopian)
- What was he reading? (the Bible)
- Who helped the Ethiopian learn about Jesus? (Philip)
- What should we share with our friends? (the Bible, Jesus)

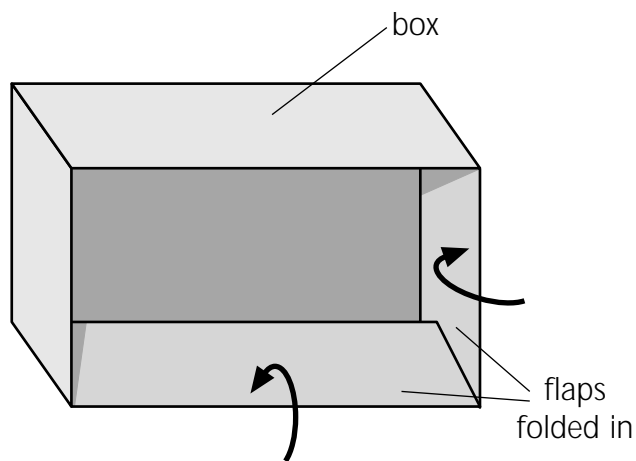

Figure A

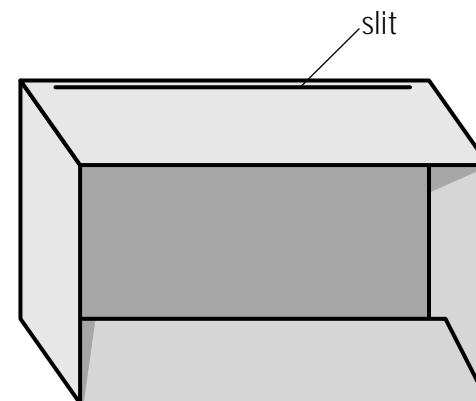

Figure B

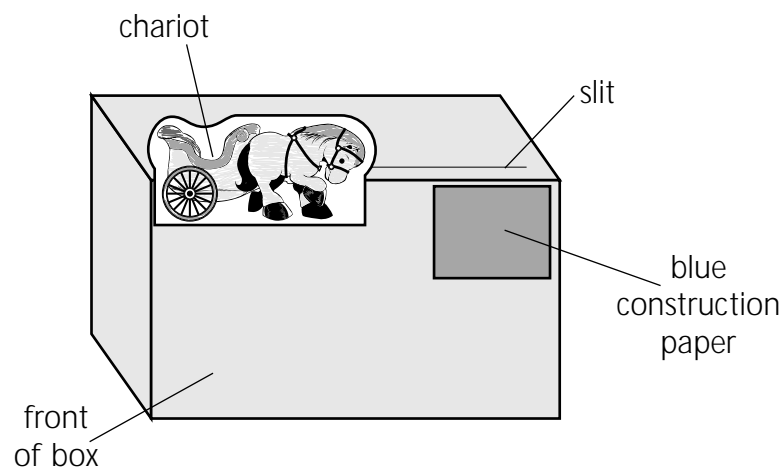

Figure C



## Gospel Chariot

The children will make a chariot to remind them that Philip helped the Ethiopian to become a disciple.

### Materials

*For each child:*

- ½ toilet paper tube
- 1 pipe cleaner
- 2 brass fasteners
- 1 piece of poster board, 3" x 4"
- crayons or markers

*For the teacher:*

- plastic disposable gloves
- hole punch
- scissors
- push pin
- tape

*Reproducible Pages:*

- Page E, 1 copy for each child
- Page F, 1 copy for each child

### Preparation

1. Cut out the Ethiopian and the Philip figures from the copies of Reproducible Page E.
2. Fold out the bottom flaps at the dotted lines. Glue the two figures back to back.
3. Cut out the horses from the copies of Reproducible Page F.
4. Fold out the bottom flaps at the dotted lines. Glue the two horses together, back to back.
5. Punch a hole in each horse where it will be attached to the chariot.
6. Cut out the wheel stencil from the copies of Reproducible Page F.
7. Prepare two wheels for each child as follows:
  - A. Trace and cut out the wheel from poster board.
  - B. Make a small hole in the center of each wheel with a push pin.

8. Prepare a "chariot" for each child as follows:
  - A. Cut each toilet paper tube in half. See Figure A.
  - B. Punch two holes in one end of the half tube to hold the reins for the horse.
  - C. Poke a hole in each side of the half tube with a push pin.
  - D. Attach the wheels to the tube by pushing a brass fastener through the hole in the wheel and then through the hole in the half tube. Do this on each side. See Figure B.
9. Make a model of the craft.

### Instructions

1. Show the children the model of the craft. *Who ran up to the Ethiopian's chariot? That's right! Philip did! Philip taught the Ethiopian about Jesus.*
2. Give each child a Philip and an Ethiopian figure and a horse to color.
3. Give each child a chariot and help them to glue the figure into it.
4. Give each child a pipe cleaner and help them to thread it through the horse and then attach each end through the holes in the chariot.
5. Write each child's name on the horse.

### Conclusion

Sing "Roll the Gospel Chariot" from the Unit 22 Song Sheet.

### Teacher Tips

- Spray paint the toilet paper tubes gold before class.

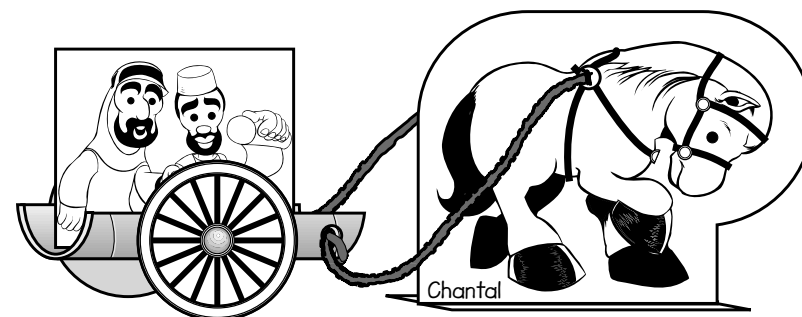

# Craft

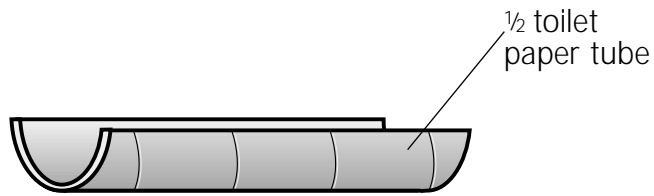

Figure A

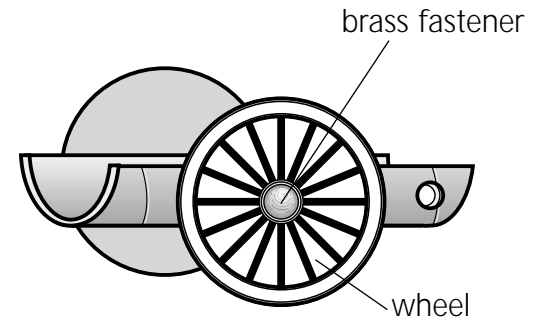
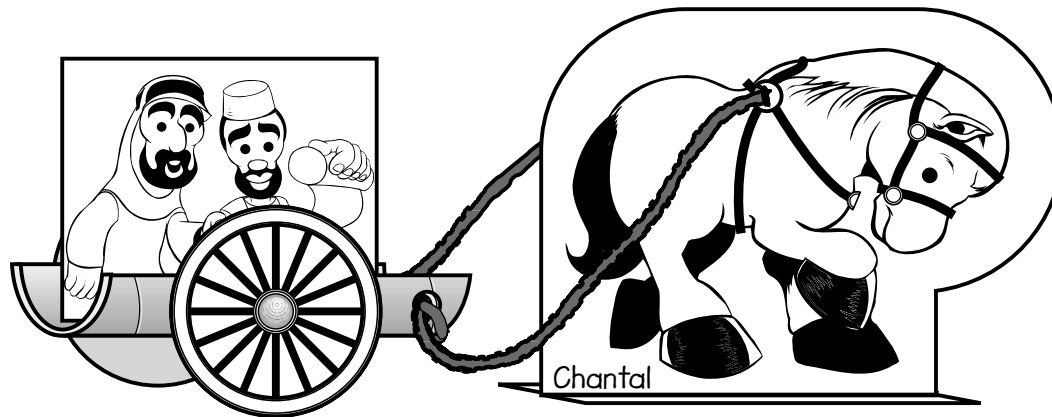

Figure B



Finished Craft





A  
P  
P  
R  
O  
A  
C  
H

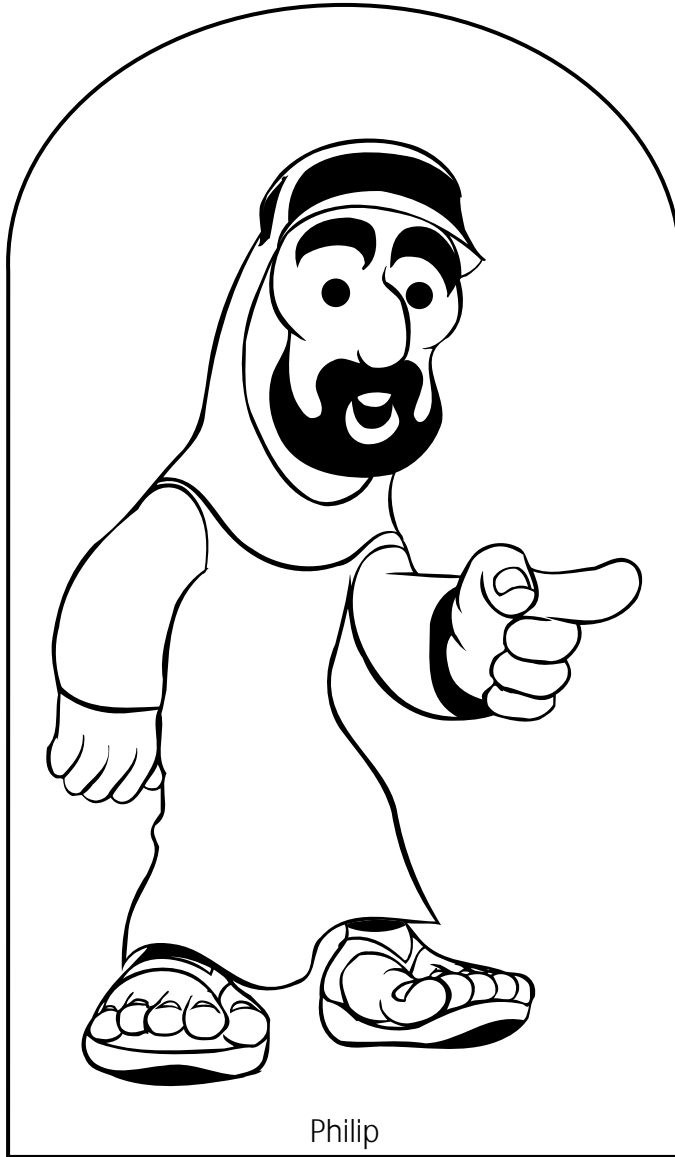

Philip



Ethiopian





R  
E  
P  
R  
E  
S  
E  
N  
T  
A  
T  
I  
O  
N

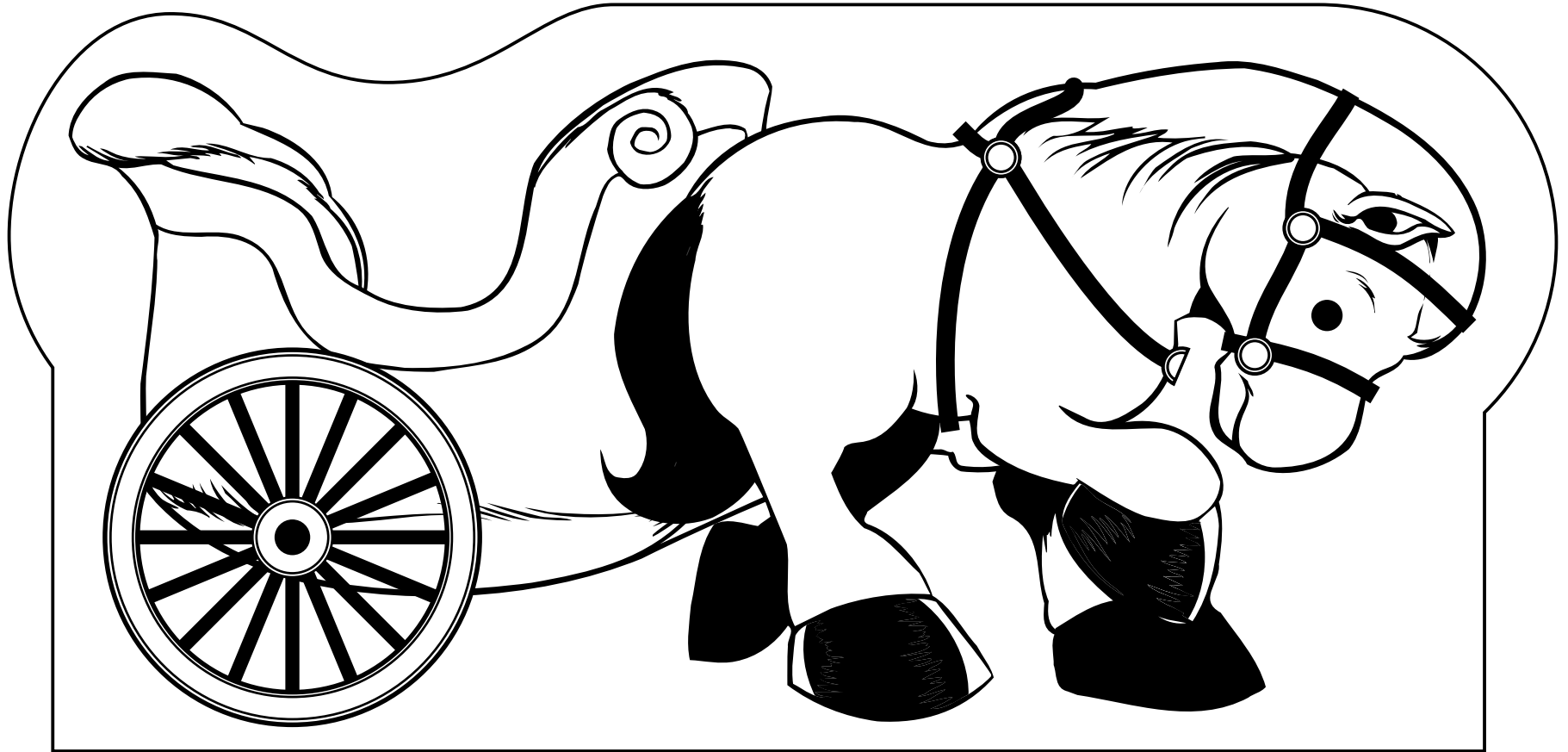

chariot







R  
e  
p  
r  
o  
d  
u  
c  
i  
b  
l  
e

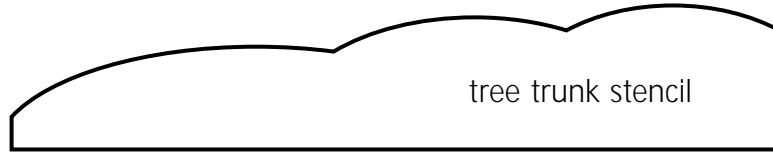

tree trunk stencil



heart  
stencil



Bible stencil

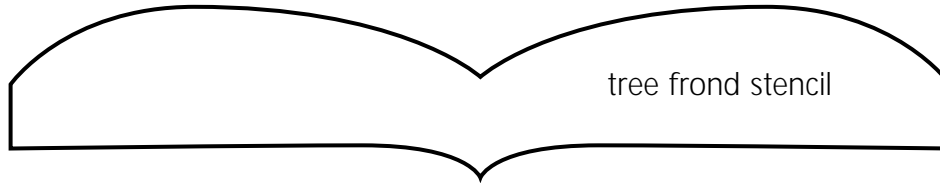

tree frond stencil

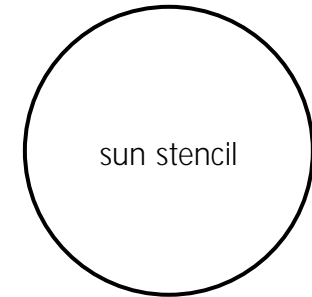

sun stencil

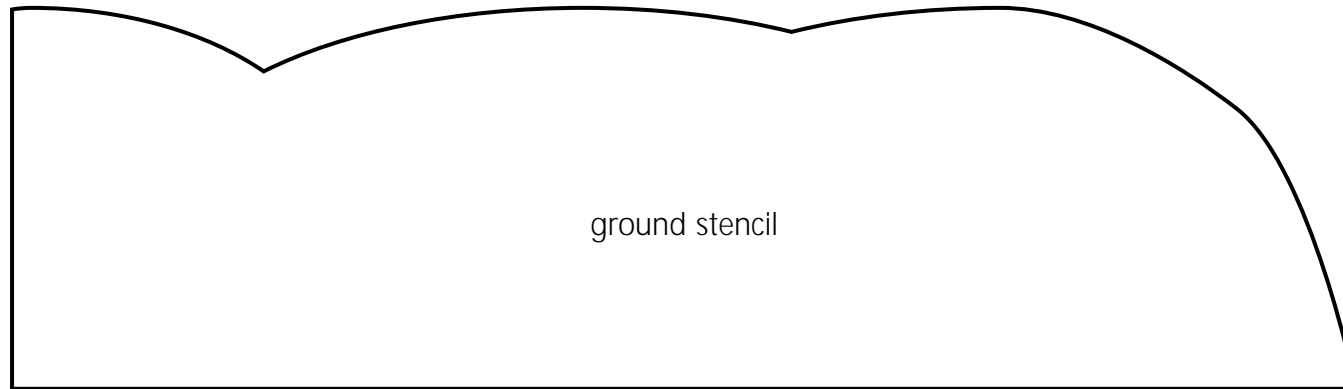

ground stencil





R  
e  
p  
r  
o  
d  
u  
c  
t  
i  
o  
n

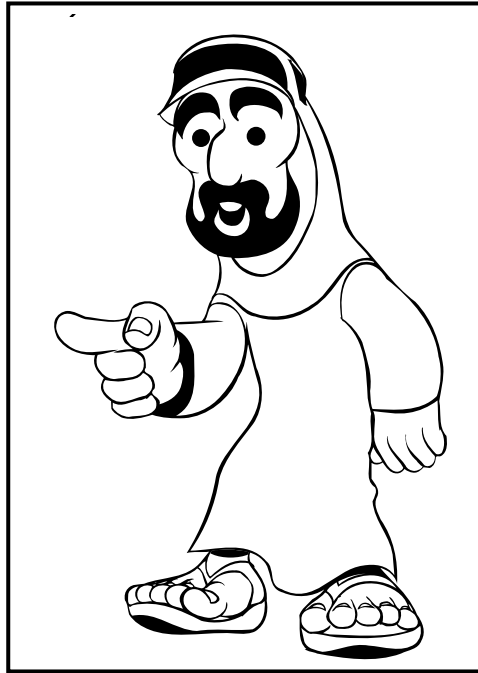

Philip

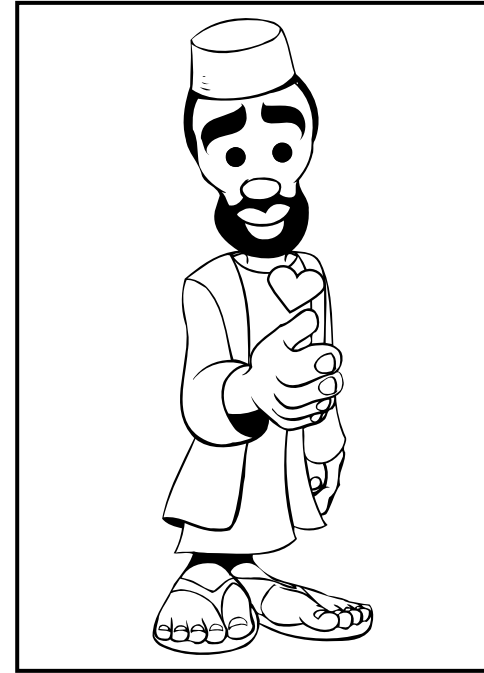

Ethiopian





R  
e  
p  
r  
e  
s  
e  
n  
t

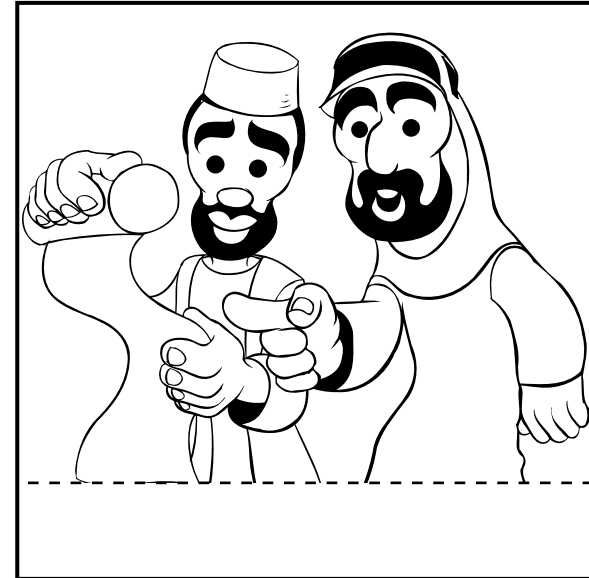
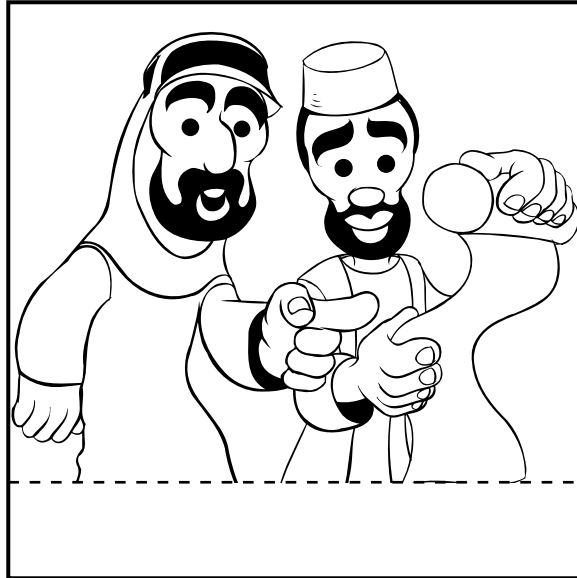

Ethiopian and Philip figures





R  
E  
P  
O  
R  
T  
C  
A  
R  
D

wheel  
stencil

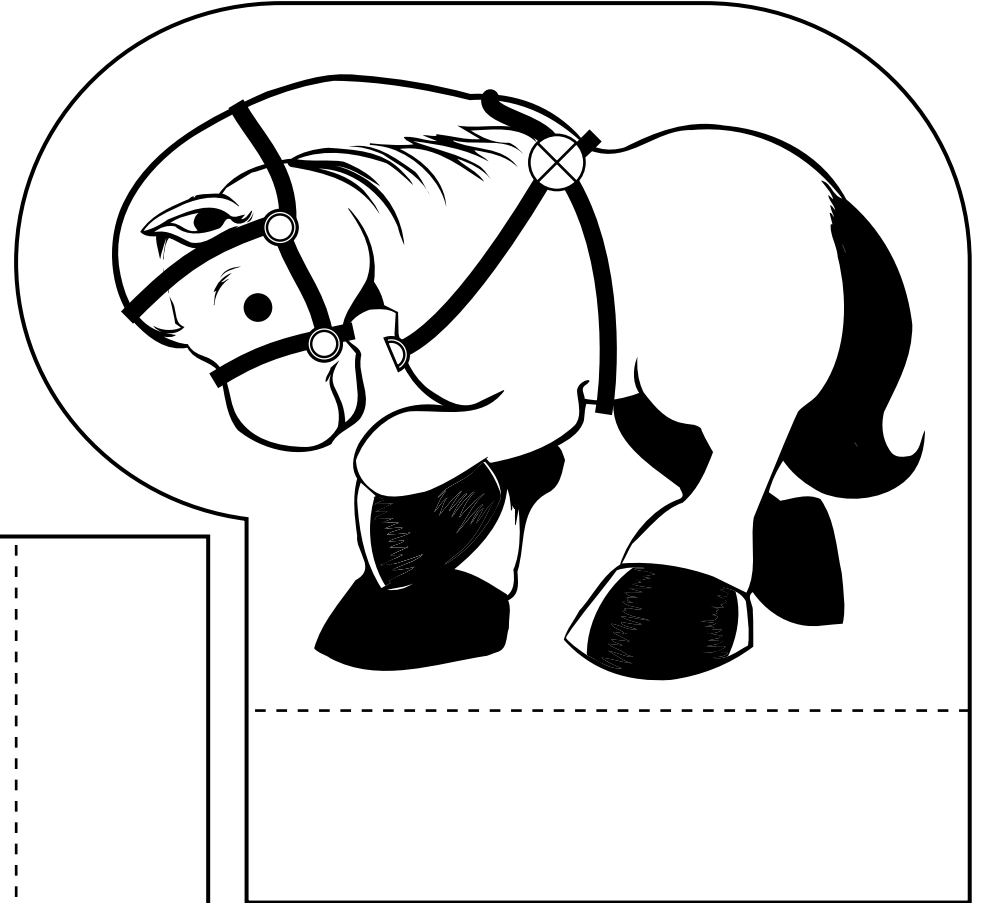
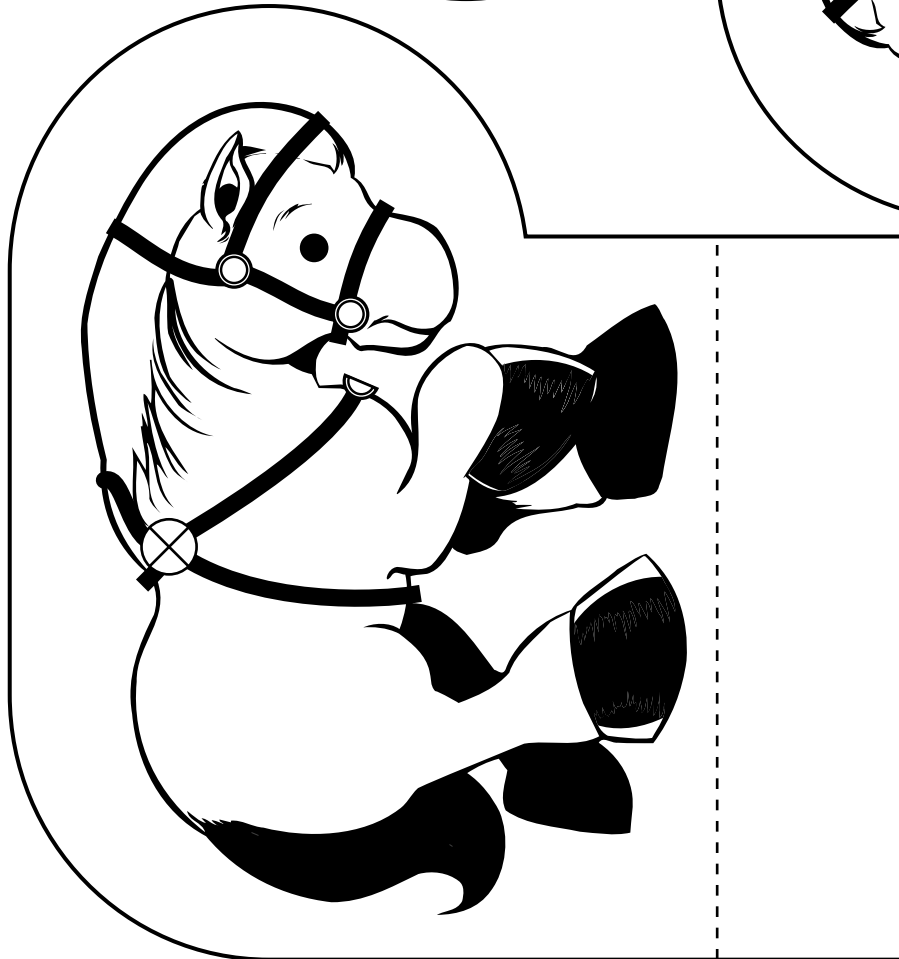
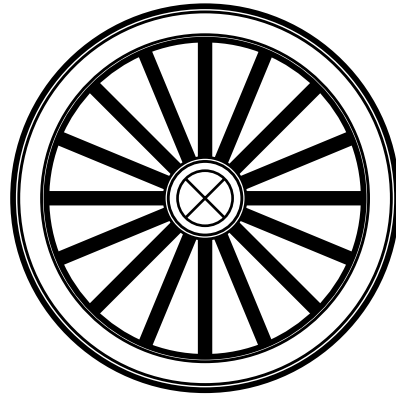

horse  
pictures

