

Listen to Jesus

Go!
Lesson 2

Lesson Objectives

- The children will state that Jesus said, "Go."
- The children will state that they will tell people about Jesus.
- The children will practice choosing to obey.

Bible Story Text

Matthew 28:18-20

Bible Truth

Jesus says, "Go!"
(Matthew 28:19)

Lesson Plan

Greeting and Registration

Preclass Activity: Preclass Centers

Welcome and Singing

Centers:

Bible Story: Jesus' Friends Go

Life Application: Red Light,
Green Light

Craft: Traffic Light

NOTE: Be sure to allow sufficient time for a snack.



Listen to Jesus

Preclass Centers

As the children arrive, guide them to a preclass center. Have no more than six children at each center.

Materials

Use the materials previously selected for this unit's preclass centers.

Preparation

1. Be sure to check the condition of the materials selected for this unit's preclass centers prior to set up. Replace any broken toys, or puzzles with missing pieces as necessary.
2. Set up the centers before the children come into the classroom.
3. Assign a teacher to each center and have the teachers stay in those centers until the singing begins.

Instructions

Guide the play in each center reinforcing the unit theme.

Teacher Tips

- **IMPORTANT:** Do not allow any small toys in the classroom. First check all toys for size. You can obtain a "safety cylinder" from a pediatrician. Any object that can fit into the cylinder is too small and could cause a child to choke.
- Be involved in the group play and offer guidance as needed.
- Wear comfortable clothes suitable for sitting on the floor.
- Smile! Be childlike in heart and alert in mind.

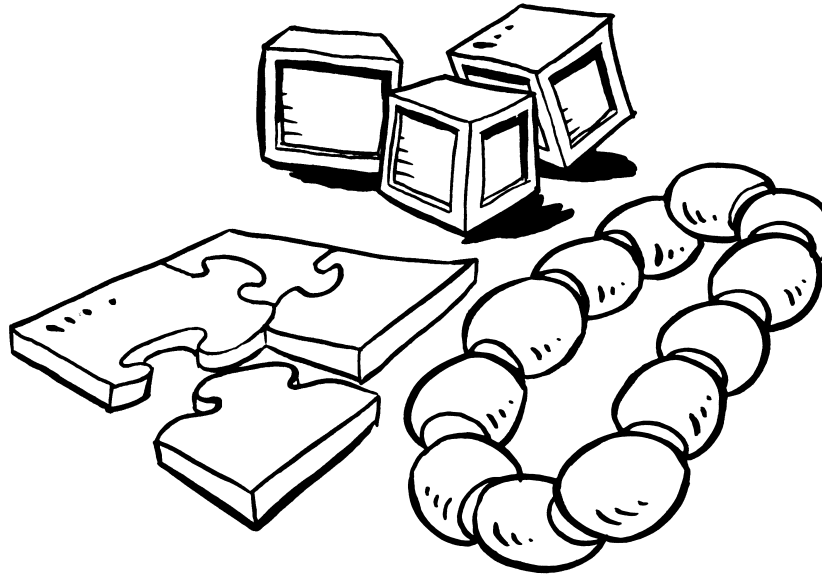

Listen to Jesus

Jesus' Friends Go

The children will learn that Jesus asked his friends to tell others that he loves them.

Bible Story Text

Matthew 28:18-20

Materials

For the teacher:

- Bible
- blue towel
- continent necklaces from the Unit 22 Lesson 1, Bible Story

Preparation

Familiarize yourself with the story.

Let's Go

Place the blue towel on the floor. Tell the children that this is the ocean and have them all sit around it being careful not to sit in the ocean.

Give each child a continent plate necklace to put on. If you have six children, have them each put on a different continent. As they put them on, say the name of each continent. *I have a special necklace for you to wear. Isn't it pretty? Your necklace is called North America.*

Place the other necklaces on the blue towel.

Open the Bible and place it in your lap. *Do you like it when someone tells you that they love you? Doesn't it make you feel good? In our Bible Story we are going to learn about Jesus. Do you know that Jesus loves you too?*

Do you know someone else who loves you? Allow the children to respond (Daddy, Mommy, grandparents, teachers, etc.)

The Bible says that long ago, when Jesus was here on earth, he wanted to tell everyone that he loved them very much.

When Jesus went back to heaven he asked his friends to tell everyone in the whole world that he loved them. Do you think that made them happy? Yes, it did!

He wanted them to go to Africa to share with the children in Africa. Have the child who is wearing the necklace of Africa stand up. He wanted them to go to Australia to share with the children in Australia. Have the child who is wearing the necklace of Australia stand up. Repeat with the remaining continents. Then have all of the children sit down.

Have each child find their matching necklace on the blue towel and put it on. Once everyone has found their match, have them put one of the continent plates back on the towel so each child is only wearing one plate.

Choose a child to find a necklace that is different from theirs. *Aaron is choosing South America.* Have them find the child who is wearing the matching necklace and give it to that child. *Look, Mary is wearing the matching South America necklace.* Then have them hug that child and tell them that Jesus loves them.

Give each child a turn.

Conclusion

Ask the children the following questions to review the story:

- Who loves you? (Jesus, God)
- What does Jesus want us to tell others? (that he loves them)
- Will you tell others that Jesus loves them? (yes!)

Sing "Jesus Loves the Little Children" and "He's Got the Whole World" from the Unit 22 Song Sheet.

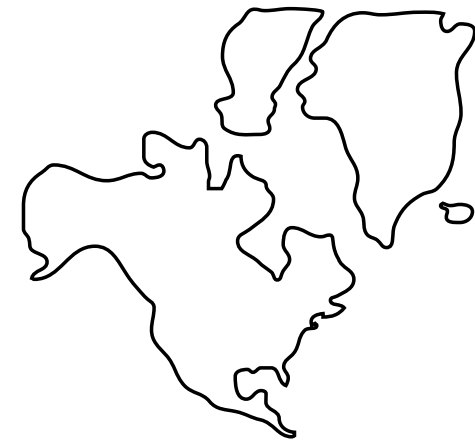

Listen to Jesus

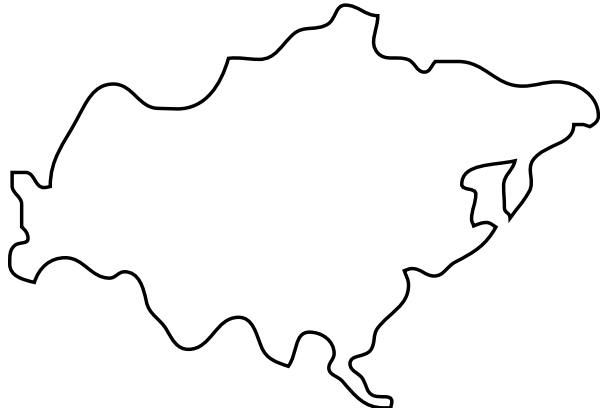

Eurasia



Africa

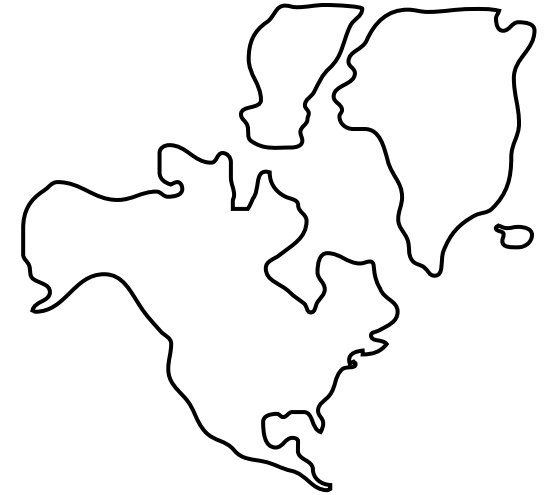

North America

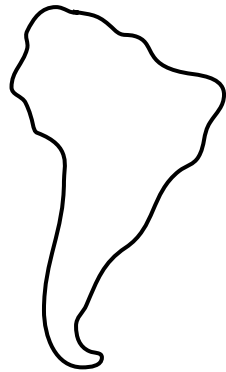

South America

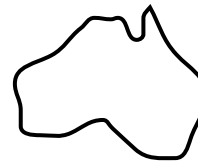

Australia



Antartica

Figure A

Listen to Jesus

Red Light, Green Light

The children will play this familiar game to remind them to obey Jesus and to reinforce the Bible Truth.

Bible Truth

Jesus says, "Go!"
(Matthew 28:19)

Materials

For the teacher:

- Bible
- red and green "light" from the Unit 22 Lesson 1, Life Application

Preparation

Familiarize yourself with the activity.

Instructions

1. Show the children the green light. *This is a green light. Who can tell me what you should do when you see a green traffic light? Yes, you go. Here is a red light. Who knows what to do when there's a red light? Yes, you stop.*
2. Explain the rules of the game. *We're going to play a game. When you see the green light that means go and you should use your walking feet and walk towards me. When you see the red light you should stop walking.*
3. Stand the children side by side in a straight line. Stand about ten feet in front of them.
4. Show the children the green light. *The light is green. It's time to go.* Encourage the children by name as they walk toward you. Especially encourage those who are walking and not running.
5. Show the children the red light. *The light is red. It's time to stop.* Encourage the children who are obeying and are stopping.
6. When the children reach you, have them return to the starting line and play the game again and again as time allows.

Bible Truth Activity

Sit down with the children and open the Bible. *The Bible is God's word. We obey the Bible, we obey God and we obey Jesus. In the Bible, Jesus says, "Go!" Can you say "go"? Let's all repeat what Jesus said together: "Jesus says, 'Go!'" Bronson, will you obey Jesus and go? Julianna, will you obey Jesus and go? Disciples obey Jesus. Disciples go and tell others about Jesus.*

Conclusion

Let's talk to God. Dear God, thank you for the Bible, and thank you for Jesus. Help us to obey Jesus and to go and tell our friends about him.

Who are you going to tell about Bible class today? What are you going to tell them?

Teacher Tips

- 2s and 3s do not comprehend this game as older children do. Be sure to tell them when it is time to stop and when it is time to go. Be sure to praise all of the children for their efforts.

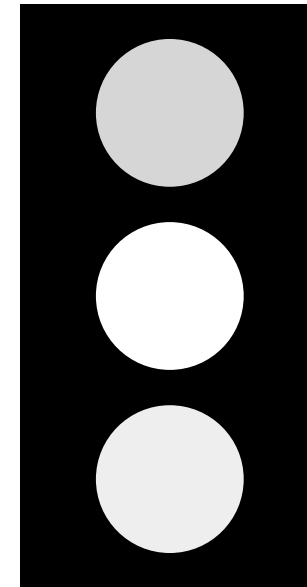

Jesus says,
"Go!"



Listen to Jesus

Traffic Light

The children will make a traffic light, so they can play the Life Application game "Red Light, Green Light" at home to remind them that Jesus says, "Go!"

Materials

For each child:

- 1 piece of black construction paper, 9" x 12"
- 1 piece of black construction paper, 4" x 12"
- 1 piece of red construction paper, 4" x 4"
- 1 piece of green construction paper, 4" x 4"
- 1 piece of yellow construction paper, 4" x 4"
- crayons

For the teacher:

- scissors
- ruler
- marker

Reproducible Pages:

- Page A, 1 copy for every five children
- Page B, 1 copy for the teacher

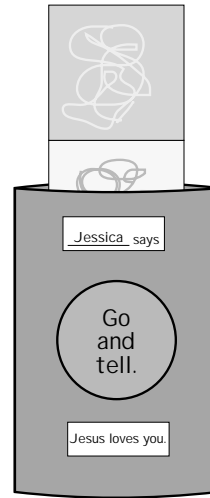

Preparation

1. Cut out the text boxes from the copies of Reproducible Page A.
2. Cut out the circle stencil from the copy of Reproducible Page B.
3. Prepare a "traffic light" from a black piece of construction paper for each child as follows:
 - A. Fold each 9" x 12" piece of black construction paper in half like a book.
 - B. Trace and cut out a circle from the middle of each folded piece of construction paper. NOTE: Be sure that you only cut through one half of the "book." See Figure A.
 - C. Place glue along the side edge of the paper and press the side edges together. NOTE: The top and the bottom should remain open. See Figure B.
4. Cut a 4" x 12" piece of black construction paper for each child.
5. Cut a 4" x 4" square each of red, yellow and green construction paper for each child.
6. In the center of each piece of green construction paper write, "Go and tell."
7. Make a model of the craft.

Instructions

1. Show the children the model of the craft. Read to them what the green light says and remind them that Jesus wants us to go and tell others about him. Explain to them that this craft will remind them to go and tell their friends about Jesus.
2. Give each child a 4" x 12" piece of black construction paper and a red, green and yellow square. Have the children color the squares.
3. Help the children to glue the squares on the black strip with red on top, yellow in the middle, and green on the bottom.
4. Give each child the folded sheet of black construction paper with the hole cut out of the middle and the two text boxes. Have the children glue the "_____ says" text box above the hole and the "Jesus loves you." text box under the hole.
5. Write each child's name on the blank line on the first text box.
6. Help each child to slide the strip of colors into the traffic light. NOTE: Be sure that the red is on top and the "Go and tell" shows through the hole.
7. Have the children slide the strip up and down in the traffic light.

Conclusion

Have a child choose a color with his traffic light and have the other children change their lights to the same color. Have each child take a turn leading.

Explain to the children that they can use their traffic light at home to play "Red Light, Green Light" with their parents.

Teacher Tips

- As the parents pick up their children, show them how to use the craft to play "Red Light, Green Light" with their children at home. Explain that the children learned that Jesus told his disciples to "Go" and tell others about him.

craft

Listen to Jesus

Go!
Lesson 2

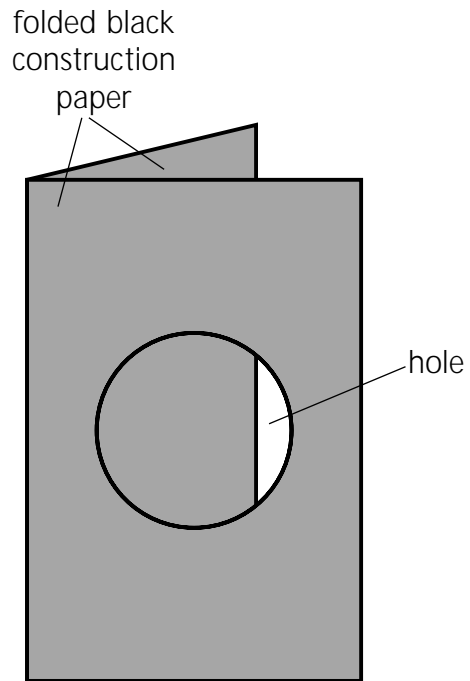

Figure A

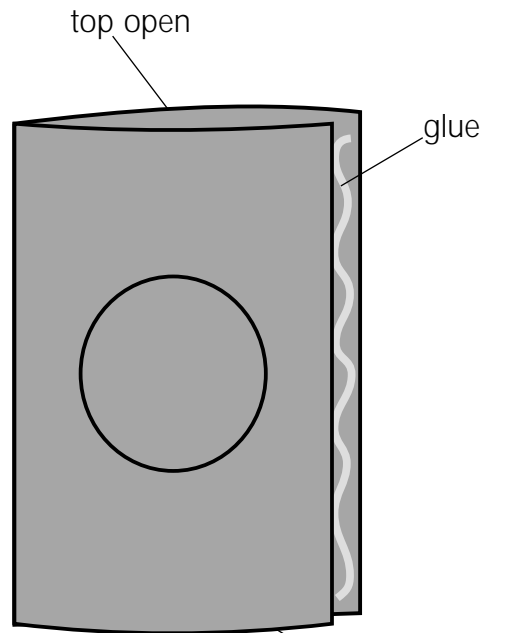
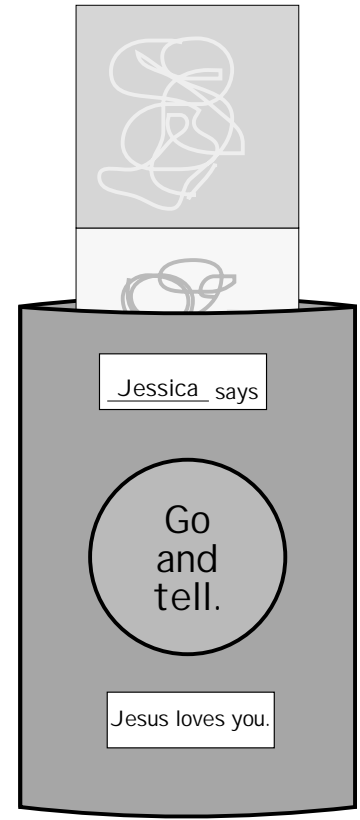

Figure B



Finished Craft





Lesson Objectives

- The children will state that Jesus said, "Go."
- The children will state that they will tell people about Jesus.
- The children will practice choosing to obey.

Bible Story Text

Matthew 28:18-20

Bible Truth

Jesus says, "Go!"
(Matthew 28:19)

Preclass Centers

As the children arrive, guide them to a pre-class center. Have no more than six children at each center.

Materials

Use the materials previously selected for this unit's preclass centers.



Listen to Jesus

Go!
Lesson 2

Lesson Plan

Greeting and Registration

Preclass Activity: Preclass Centers

Welcome and Singing

Centers:

Life Application: Learning To Obey

Bible Story: Jesus' Friends Go

Craft: House to House

NOTE: Be sure to allow sufficient time for a snack.

Preparation

1. Be sure to check the condition of the materials selected for this unit's preclass centers prior to set up. Replace any broken toys, or puzzles with missing pieces as necessary.
2. Set up the centers before the children come into the classroom.
3. Assign a teacher to each center and have the teachers stay in those centers until the singing begins.

Instructions

Guide the play in each center reinforcing the unit theme.

Teacher Tips

- **IMPORTANT:** Do not allow any small toys in the classroom. First check all toys for size. You can obtain a "safety cylinder" from a pediatrician. Any object that can fit into the cylinder is too small and could cause a child to choke.
- Be involved in the group play and offer guidance as needed.
- Wear comfortable clothes suitable for sitting on the floor.
- Smile! Be childlike in heart and alert in mind.

Learning To Obey

The children will sing a song and play a game with cards, each of which portrays a different action that shows children obeying God.

Bible Truth

Jesus says, "Go!"
(Matthew 28:19)

Materials

For the teacher:

- Bible
- Cards from the Unit 22 Lesson 1, Life Application

Preparation

1. Familiarize yourself with the song "Learning to Obey" from the Unit 22 Song Sheet.
2. Arrange the cards in the order of the verses in the song.

Instructions

Who can tell me what it means to obey? Allow several children to respond. Do you know that God tells us to obey? Who should we obey? We obey God. We obey Jesus. We obey our parents. We obey grown-ups that take care of us. Victoria, who do you obey? William, who do you obey?

Using only one set of cards, hold up a card. What is this a picture of? This is a mouth. What can we do with our mouth? We can smile and obey happily. We can tell our friends about Jesus. We can invite them to come to church. When we tell our friends about church, we obey Jesus.

Sing the first verse of "Learning to Obey" from the Unit 22 song sheet.

Hold up another card. What is this a picture of? This is someone saying, "Shhh!" Why do you think she is saying, "Shhh!" Allow responses. William, will you obey when Mommy says, "Shhh!"?

Repeat this with the remaining cards and sing the corresponding verse of the song after each card.

- Feet - go to help others
- Ears - listen to grown-ups and the Bible
- Hands – pray to God
- Arms – hug and are friendly

Listen to Jesus

Go! Lesson 2

Give each child a card to hold as you finish with it.

Place the matching cards on the floor face up. Have each child find the match to the card they are holding.

Help each child to tell the group what they can do to obey God according to the picture on the card.

Bible Truth Activity

Let's all sit down now, and open the Bible. Open the Bible in your lap. The Bible is God's Word. We obey the Bible, we obey God, and we obey Jesus.

In the Bible, Jesus says, "Go!" Can you say "go"? Let's all say that together. "Jesus says, 'Go!'"

Bronson, will you obey Jesus and go tell your friends about him? Julianna, will you obey Jesus and go tell your friends about him? Disciples obey Jesus. Disciples go and tell others about Jesus.

Conclusion

Let's talk to God. Dear God, thank you for the Bible, and thank you for Jesus. Help us to obey Jesus and to go and tell our friends about him.

Who are you going to tell about Bible class today? What are you going to tell them?



Jesus' Friends Go

The children will learn that Jesus asked his friends to tell others that he loves them.

Bible Story Text

Matthew 28:18-20

Materials

For the teacher:

- Bible
- blue towel
- continent necklaces from the Unit 22 Lesson 1, Bible Story

Preparation

Familiarize yourself with the story.

Let's Go

Place the blue towel on the floor. Tell the children that this is the ocean and have them all sit around it being careful not to sit in the ocean.

Give each child a continent plate necklace to put on. If you have six children, have them each put on a different continent. As they put them on, say the name of each continent. *I have a special necklace for you to wear. Isn't it pretty? Your necklace is called North America.*

Place the other necklaces on the blue towel.

Open the Bible and place it in your lap. *Do you like it when someone tells you that they love you? Doesn't it make you feel good? In our Bible Story we are going to learn about Jesus. Did you know that Jesus loves you too?*

Do you know someone else who loves you? Allow the children to respond (Daddy, Mommy, grandparents, teachers, etc.)

The Bible says that long ago, when Jesus was here on earth, he wanted to tell everyone that he loved them very much.

When Jesus went back to heaven he asked his friends to tell everyone in the whole world that he loved them. Do you think that made them happy? Yes, it did!

Listen to Jesus

Go! Lesson 2

He wanted them to go to Africa to share with the children in Africa. Have the child who is wearing the necklace of Africa stand up. He wanted them to go to Australia to share with the children in Australia. Have the child who is wearing the necklace of Australia stand up. Repeat the remaining continents. Then have all of the children sit down.

Have each child find their matching necklace on the blue towel and put it on. Once everyone has found their match, have them put one of the continent plates back on the towel so each child is only wearing one plate.

Choose a child to find a necklace that is different from theirs. *Aaron is choosing South America.* Have them find the child who is wearing the matching necklace and give it to that child. *Look, Mary is wearing the matching South America necklace.* Then have them hug that child and tell them that Jesus loves them.

Give each child a turn.

Conclusion

Ask the children the following questions to review the story:

- Who loves you? (Jesus, God)
- What does Jesus want us to tell others? (that he loves them)
- Will you tell others that Jesus loves them? (yes!)

Sing "Jesus Loves the Little Children" and "He's Got the Whole World" from the Unit 22 Song Sheet.



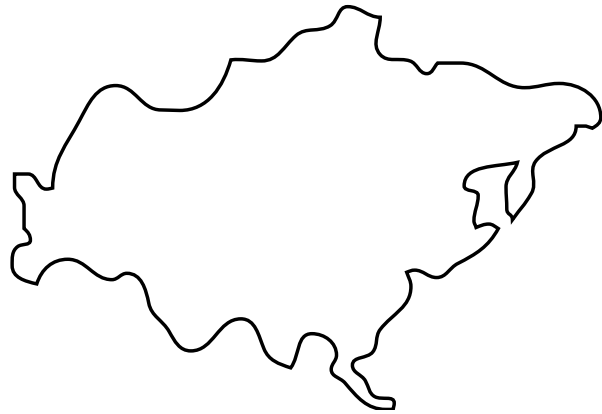

Eurasia



Africa

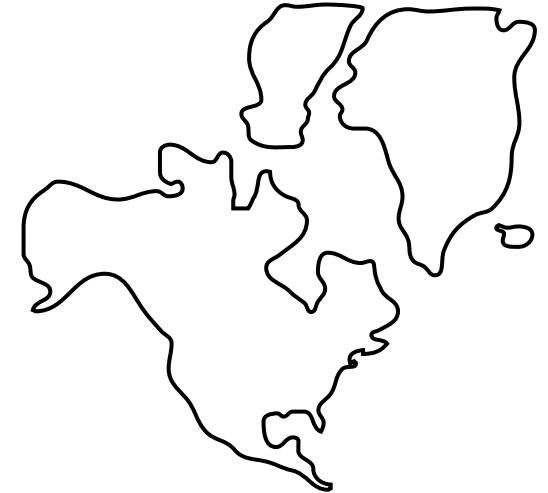

North America

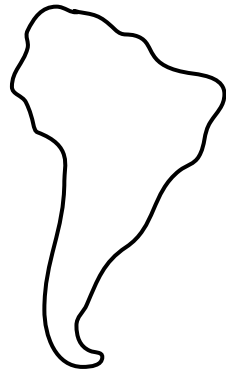

South America

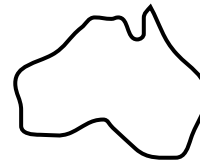

Australia

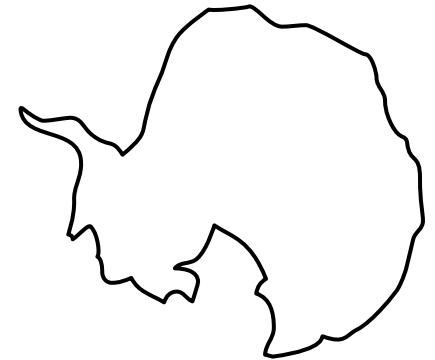

Antartica

Figure A



House to House

The children will make a craft to remind them that Jesus wants them to share about him with their friends and neighbors.

Materials

For each child:

- 2 different brightly colored pieces of construction paper, 9" x 12"
- crayons
- glue stick
- 1 piece of poster board, 4" x 2½"
- 1 pipe cleaner

For the teacher:

- ruler
- hole punch
- packing tape
- scissors
- tape
- pen
- black marker

Reproducible Pages:

- Page C, 1 copy for the teacher
- Page D, 1 copy for each child

Preparation

1. Cut out the stencils from the copies of Reproducible Page C.
2. Trace and cut out two houses, two roofs, four windows and two doors for each child from construction paper. NOTE: Use various colors of construction paper.
3. Prepare a walking child for each child as follows:
 - A. Cut out the walking child from the copies of Reproducible Page D.
 - B. Glue the walking child onto a 4" x 2½" piece of poster board.
 - C. Trim the poster board to the box around the walking child.
 - D. Punch two holes at the bottom of the child where indicated.

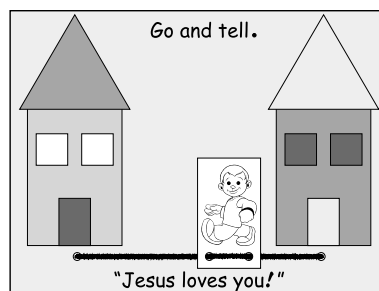

Listen to Jesus

Go! Lesson 2

4. Prepare a piece of construction paper for each child as follows:
 - A. Write "Go and tell." at the top and "Jesus loves you!" at the bottom of each piece of construction paper.
 - B. Punch two holes in each piece of construction paper 1" from the bottom of the page and 2½" in from the sides. See Figure A.
 - C. Put one end of the pipe cleaner through the left hole and tape that end to the back of the paper. See Figure B.
5. Make a model of the craft.

Instructions

1. Show the children the model of the craft. Move the walking child and explain to the children that this child is being obedient to Jesus. He is going to his friend's house to tell him that Jesus loves him.
2. Help the children to assemble two houses, one at a time, as follows:
 - A. Give each child a house and a roof. Have them glue the roof onto the house.
 - B. Give each child a door to glue onto the house.
 - C. Give the child two windows to glue onto the house.
3. Give each child the prepared piece of construction paper. Have the children glue one house on the left side of the paper above the hole and the other house on the right side of the paper above the hole.
4. Give each child a walking child. Help them to thread the child onto the pipe cleaner.
5. Help the children to thread the end of the pipe cleaner through the remaining hole in the paper and tape it onto the back.
6. Write each child's name on their craft.

Conclusion

Show the children how to move the walking child from side to side. Let each child tell you who he is going to visit in his neighborhood to tell them that Jesus loves them.

Teacher Tips

- For younger children, glue the houses together before class.

C
r
a
f
t

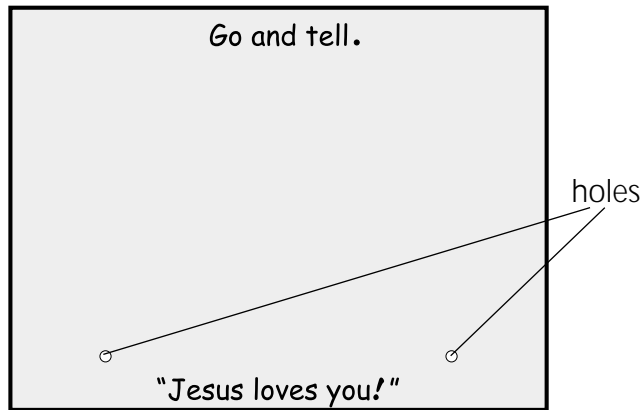

Figure A

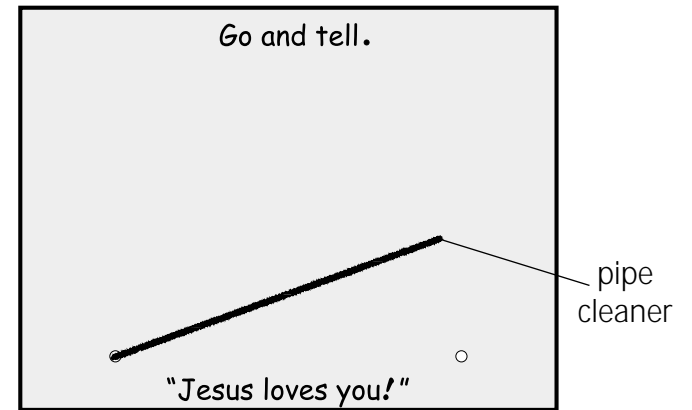
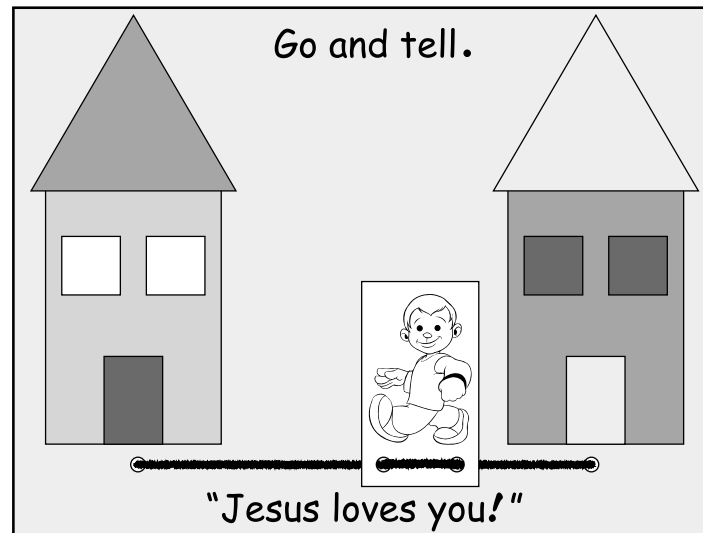

Figure B



Finished Craft





R
e
p
r
o
d
u
c
i
b
l
e

_____ says	Jesus loves you.
_____ says	Jesus loves you.
_____ says	Jesus loves you.
_____ says	Jesus loves you.
_____ says	Jesus loves you.

text boxes





R
e
p
r
o
d
u
c
t
i
o
n
s

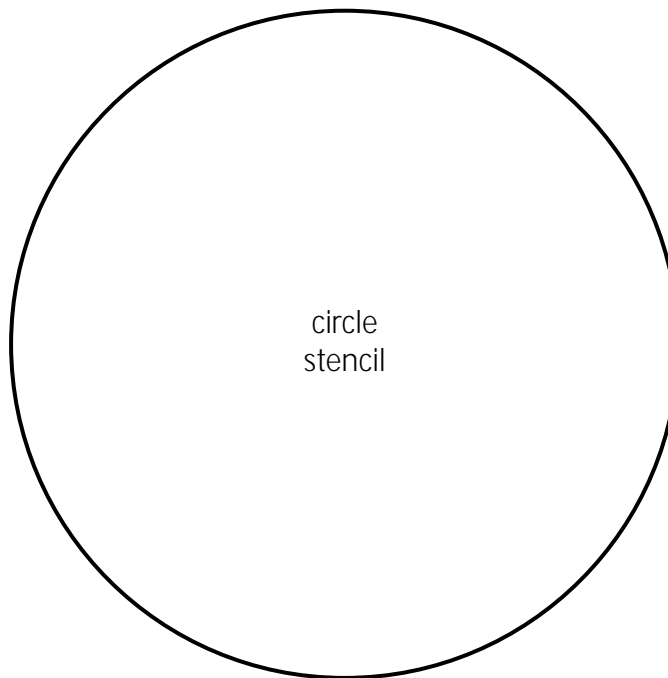



R
e
p
r
o
d
u
c
e
-
b
-
e

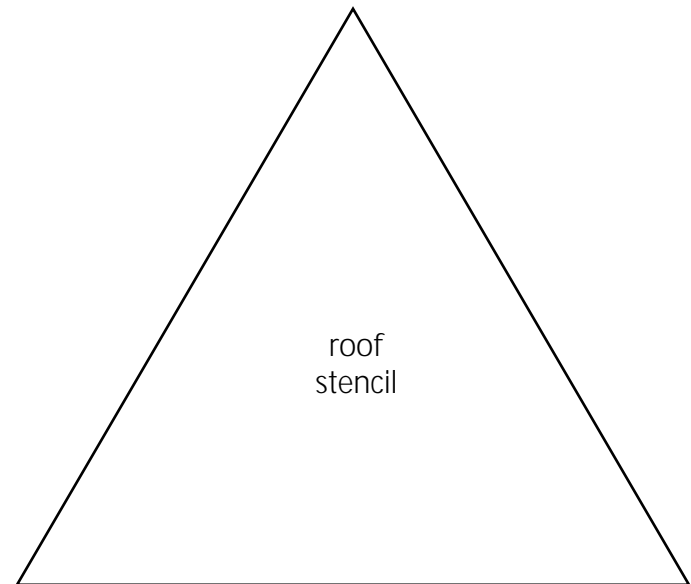
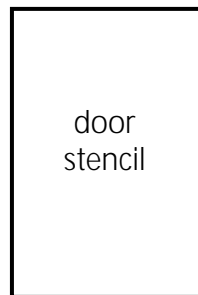
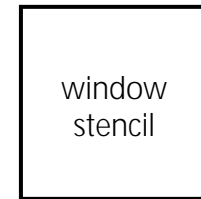
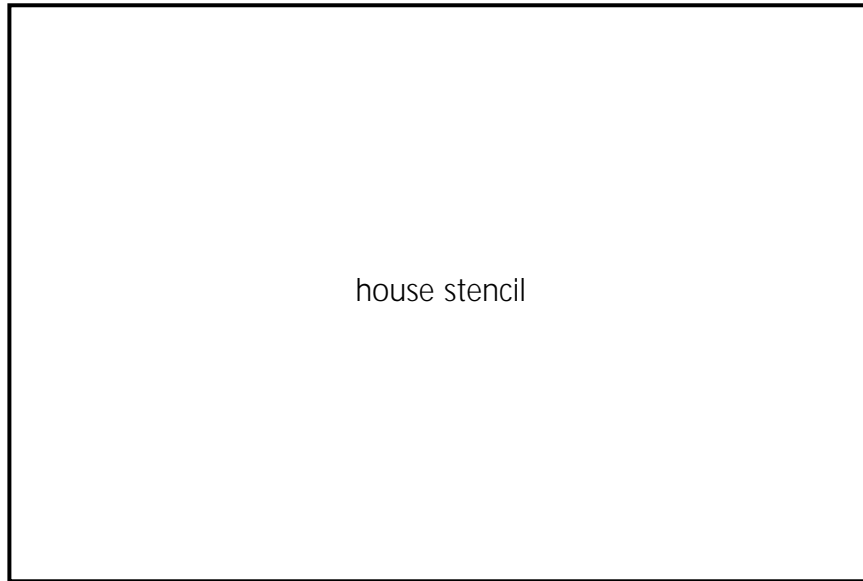



R
e
p
r
e
s
e
n
t
a
t
i
o
n

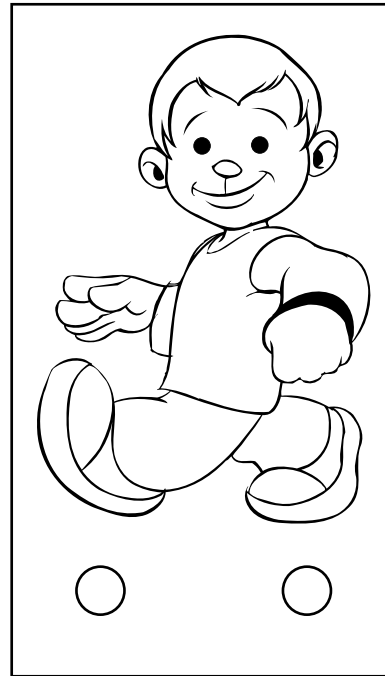

walking child figure

