

# Jonah

### Lesson Objectives

- The children will practice identifying happy obedience and unhappy obedience.
- The children will list ways that they have been obedient during the past week.
- The children will ask God to help them obey happily.

### Lesson Text

Jonah 1-4

### Scripture Memory Verse

Give thanks to the Lord for he is good; his love endures forever.

*Psalm 106:1*

### Lesson Plan

Greeting and Registration

Preclass Activity: Fish Chart

Welcome and Singing

Centers:

Bible Story: Jonah's Heart

Life Application: Let's Pretend

Craft: Jonah and the Fish

NOTE: Be sure to allow sufficient time for a snack.



# Pre class



# Jonah

## Fish Chart

The children will share how they obeyed at home in the past week.

### Materials

*For each child:*

- 1 piece of construction paper
- crayons

*For the teacher:*

- chart and fish from the Unit 20 Lesson 5, Preclass Activity
- black marker
- pencil
- scissors
- masking tape

### Preparation

1. Hang the chart at the children's eye level.
2. Using a fish from the Unit 20 Lesson 5, Preclass Activity trace and cut out three fish for each child from construction paper.

### Instructions

1. Give three fish to each child and have them color them.
2. When they have finished coloring have them bring the fish to you. Show them the fish on the chart under their name. Remind them of what is written on each fish. Ask them to tell how they did in each of the areas.
3. Write down one answer on each fish. For example: Obeyed the first time, obeyed happily, etc.
4. Put a piece of rolled tape on the back of each fish.
5. Help the child to put the three fish in the column with their name under the other fish.

### Conclusion

Encourage the children for the ways that they happily obeyed.

### Teacher Tips

- If some of the children cannot think of ways that they did obey happily then have them think of ways that they can obey happily this week.

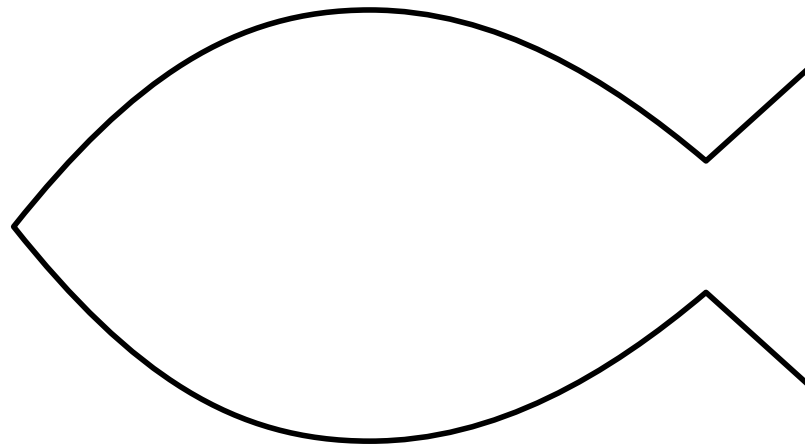

## Jonah

### Jonah's Heart

The children will review the story of Jonah.

#### Lesson Text

Jonah 4:1-4

#### Materials

For the teacher:

- robe
- Bible

#### Preparation

1. Familiarize yourself with the story.
2. Before the children arrive dress as Jonah.

#### Tell it Again

*Hello! Do you remember who I am? My name is Jonah. Do you remember where you can find my story? In the Bible! That's right! My story is in the book of Jonah in the Bible. We are going to play a review game together. I'm going to tell you my story and I want you to help me. As I tell my story, I want you to decide whether or not I am telling it correctly. If I say the wrong thing you can raise your hand and help me tell the story the right way. Are you ready?*

*A long time ago God told me to go to the city of St. Louis. (pause and encourage the children to comment) (No—Nineveh) Oh! That's right, I went to the city of Nineveh. God told me to go Nineveh and teach the people to stop doing bad things and start pleasing God. Because I cared so much for the people, I obeyed God. (pause and encourage the children to comment) (No—Jonah did not care about the people of Nineveh. He disobeyed God and ran away on a boat.) You're right! I did not care about the people of Nineveh. I decided to run away and get on a boat. While I was on the boat, a great storm came and the people on the boat decided to throw me overboard into the water. While I was in the water I was swallowed by an elephant! (pause and encourage the children to comment)*

*(No—a big fish) You are right! I was swallowed by a fish. I stayed in that fish for three days. Boy did it smell in there! I danced the whole time I was in the fish. (pause and encourage the children to comment) (No—Jonah prayed) Oh! Yeah! I prayed to God. And God heard my prayer. He told the fish to spit me out onto land.*

*After that, I decided to disobey God again. (pause and encourage the children to comment) (no—Jonah decided to obey God and go to the city of Nineveh) You are right! I decided to obey God and go to the city of Nineveh and tell them that God wanted them to change. After I preached to them, the people started changing and pleasing God. This made me so happy! (pause and encourage the children to comment) (no—Jonah was angry that God was not going to destroy the city) No, I was not happy. I was angry with God and all I could think about was myself. I wanted God to destroy Nineveh because the people had been so mean to God. I went up to a hillside and sat there, angry with God.*

*Soon it got to be very hot. God provided an umbrella to give me shade. (pause and encourage the children to comment) (no—a vine) You're right! It was a vine that God gave me to give me shade. I was very thankful. But then the vine died and I was happy. (Pause and encourage the children to comment) (no—Jonah was angry at God again).*

*God used the vine to help me see how selfish I was. I loved the vine more than I loved the people in Nineveh. God helped me see how much he cared for me and the people of Nineveh. I was being selfish and unloving to the people of Nineveh! I'm sure glad God helped me see my heart so that I could be different.*

#### Conclusion

Explain to the children that God wants them to care for the people around them too.



# Jonah



## Jonah

## Let's Pretend

The children will note the difference between obeying happily and unhappily.

## Scripture Memory Verse

Give thanks to the LORD for he is good; his love endures forever.  
Psalm 106:1

## Materials

For the teacher:

- scissors
- stapler
- a bag or a hat
- 1 piece of yellow construction paper

Reproducible Pages:

- Page A, 1 copy for the teacher

## Preparation

1. Cut out the commands from the copy of Reproducible Page A and put them in the bag.
2. Make a paper crown as follows, see Figure A:
  - A. Cut the yellow piece of construction paper in half making two 4½" x 12" pieces.
  - B. Cut one side of each piece so that it is jagged.
  - C. Staple the two pieces together.
  - D. Wrap the crown around your head and staple it so that it fits you.
3. Familiarize yourself with the activity.

## Instructions

1. Explain to the children that they are going to play a game called "Let's Pretend." Put the crown on your head. *Whoever is wearing the crown is the teacher. The teacher will choose a command action for me to do.*
2. Choose a child to go first. Put the crown on their head.

3. Have the child choose a command from the bag and tell you what to do.
4. Listen to the command and then, reluctantly follow the instructions.
5. Ask the children, *Did I obey happily?*
6. Have the child tell you the command again. This time obey happily.
7. Have the first child choose the next child to put on the crown and play the teacher.
8. Give each child a turn to be the teacher. Alternate between obeying happily and not obeying happily.

## Scripture Memory Activity

Put the crown on your head and recite the memory verse. Then place the crown on a child's head and have them say the verse. Have that child put the crown on another child's head for them to recite the verse. Continue until each child has had a turn.

## Conclusion

Encourage the children who have been bringing their friends to class. Explain to the children that when they obey happily it makes them happy and it makes people want to be their friends and learn about God.

Say a prayer with the children asking God to help you all to obey happily.

## Teacher Tips

- Have fun with this activity! Be very dramatic and animated to gain the children's attention. Over exaggerate your responses to give the children a clear picture of what it means to obey happily vs. unhappily.
- Be sure to help the children with the memory verse.



# Jonah

Life  
●  
A  
P  
P  
L  
I  
C  
A  
T  
I  
O  
N  
↓

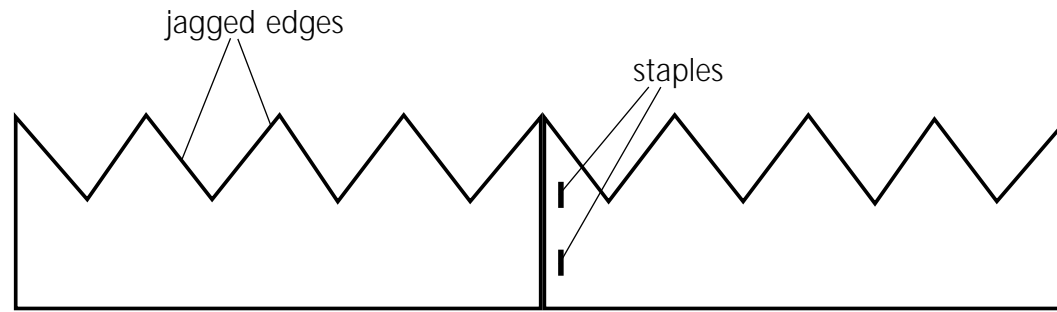

Figure A



# Jonah

## Jonah and the Fish

The children will make a craft to remind them of the story of Jonah.

### Materials

*For each child:*

- 1 white paper plate
- 1 piece of yarn, 12"
- two large wiggly eyes
- 1 piece of red construction paper, 3" x 3"
- 1 piece of blue construction paper, 6" x 5"
- glue stick

*For the teacher:*

- scissors
- 1 piece of construction paper for every 5 children
- black marker
- hole punch
- tape
- white glue

*Reproducible Pages:*

- Page B, one copy for the teacher
- Page C, one copy for every five children

### Preparation

1. Fold each paper plate in half.
2. Punch a hole in the center of the fold. See Figure A.
3. Cut out the tail and tongue stencils from the copy of Reproducible Page B.
4. Trace and cut out one tail for each child from blue construction paper.
5. Trace and cut out one tongue for each child from red construction paper.
6. Prepare a Jonah figure for each child as follows:
  - A. Glue each copy of Reproducible Page C to a piece of construction paper.
  - B. Cut out one Jonah figure for each child.
  - C. Punch a hole in the top of each figure.
  - D. Cut a 12" piece of yarn for each child
  - E. Tie one piece of yarn to the hole in each figure.
7. Make a model of the craft following the instructions.

### Instructions

1. Show the children the model of the craft. Remind the children of the story of Jonah. That he didn't want to obey God and at first he ran away. When he ran away a fish swallowed him. *Do you know what Jonah did while he was in the fish? Yes, he prayed. And after the fish spit him out, Jonah decided to obey God.* Explain that Jonah was not happy to obey God but he did it anyway. God wants us to obey him and our families but he wants us to do it happily.
2. Give each child a folded paper plate, two eyes and a tongue. Have them glue the tongue inside the paper plate and the two eyes to the top. See Figure B.
3. Give each child a tail to glue to the underside of the fish. See Figure C.
4. Have the children color the plate to look like a fish.
5. Give each child a Jonah figure to color.
6. Help each child to thread the end of the string through the hole in the fish's mouth.
7. Place a piece of tape on the end of the string to prevent it from falling back through the hole. See Figure D.

### Conclusion

Have the children use their crafts to retell the story of Jonah.

### Teacher Tips

- Use white glue to help the children glue the eyes onto their fish.

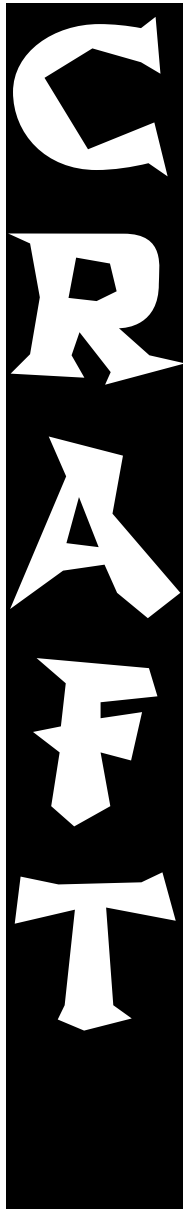
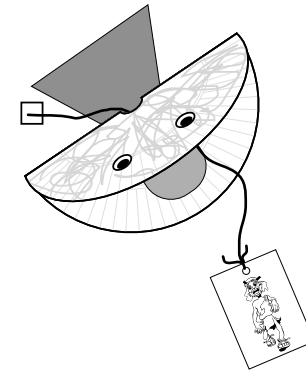

# CRAFT

## Jonah

## God Cares

Lesson 6

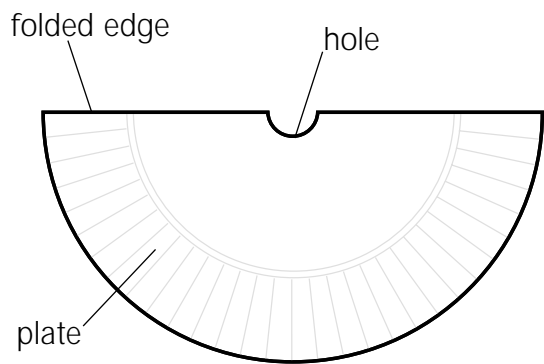

Figure A

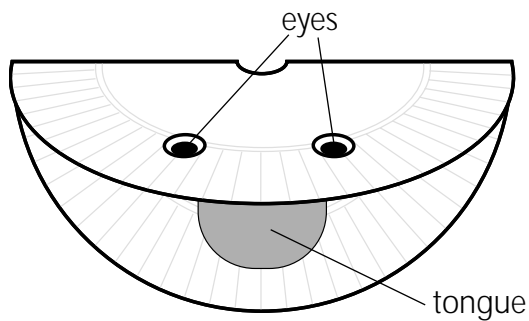

Figure B

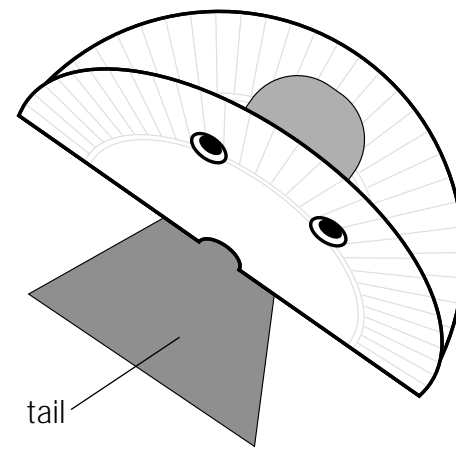

Figure C

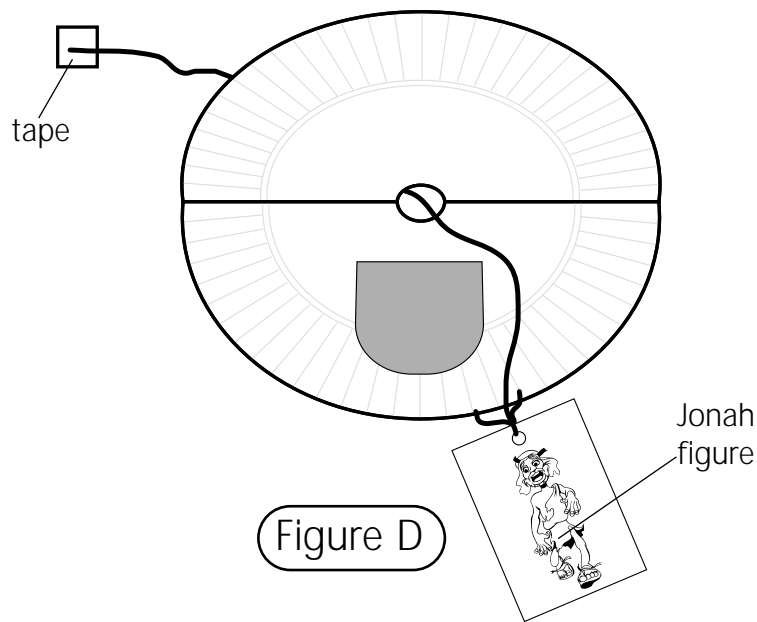
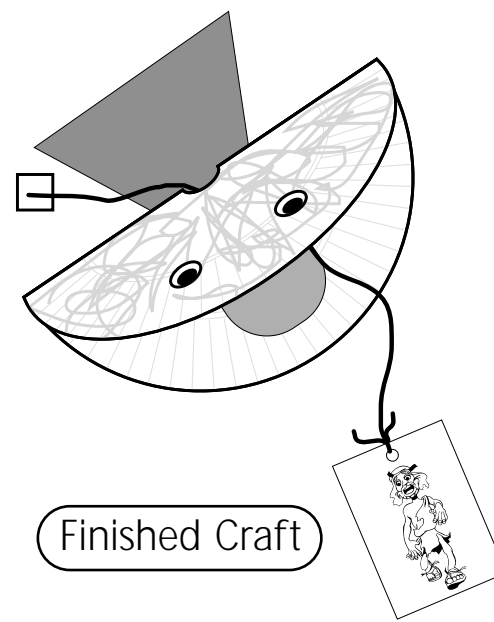

Figure D







Pre class



### Lesson Objectives

- The children will practice identifying happy obedience and unhappy obedience.
- The children will list ways that they have been obedient during the past week.
- The children will ask God to help them obey happily.

### Lesson Text

Jonah 1-4

### Scripture Memory Verse

Give thanks to the Lord for he is good; his love endures forever.  
Psalm 106:1

### Vine Chart

The children will think of ways that they have been obedient in class.

#### Materials

*For each child:*

- 3 pieces of construction paper, 4" x 4"
- 1 piece of green construction paper, 6" x 6"
- crayons

*For the teacher:*

- scissors
- black marker
- masking tape
- 1 large piece of poster board
- 1 piece of white paper

*Reproducible Pages:*

- Page D, one copy for the teacher

#### Preparation

1. On the white paper write "Ways We Obey in Class."
2. Cut out the flower and leaf stencils from the copy of Reproducible Page D.
3. Trace and cut out three flowers for each child from construction paper.
4. Trace and cut out three leaves for each child from green construction paper.
5. Cut the poster board into 4" x 28" strips.
6. Tape the poster board strips together end to end.
7. Before class tape the poster board to the wall of the classroom.

#### Instructions

1. Give each child 3 flowers to color.
2. On the back of each flower write one way the child has happily obeyed in class.
3. Help the child to tape the flowers onto the poster board with one leaf in between each flower, making a vine.

#### Teacher Tips

- Give the flowers back to the children when they leave and encourage them on how obedient they were. If correction is necessary, keep it positive.

### Lesson Plan

Greeting and Registration

Preclass Activity: Vine Chart

Welcome and Singing

Centers:

Game: Go Fish

Craft: Noodle Necklace

Life Application: Let's Pretend

NOTE: Be sure to allow sufficient time for a snack.

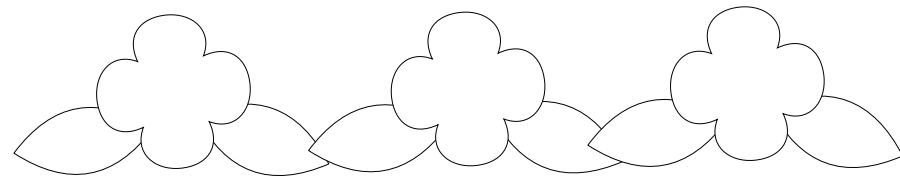



## Go Fish

The children will demonstrate the difference between happy and unhappy obedience and how both responses make God feel.

### Materials

*For each child:*

- 1 piece of construction paper, 3" x 5" (use a variety of colors)
- 1 paper clip

*For the teacher:*

- 1 dowel rod or stick
- a 30" piece of string
- 1 round magnet with a hole in the middle
- black marker
- scissors
- blue sheet or towel

*Reproducible Pages:*

- Page E, one copy for the teacher



### Preparation

1. Cut out the fish stencil from the copy of Reproducible Page E.
2. Trace and cut out one fish for each child from construction paper.
3. On each fish write an instruction for the child to obey: hug the teacher, touch your toes, smile at a friend, etc.
4. Place one paper clip on each fish.
5. Tie the magnet to one end of the string and tie the other end to the dowel rod. This is the fishing pole.
6. Before the children arrive place the sheet on the floor as water and place the fish on top of the sheet.

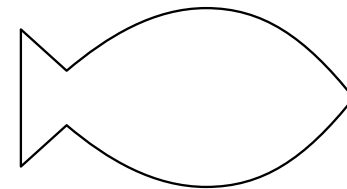
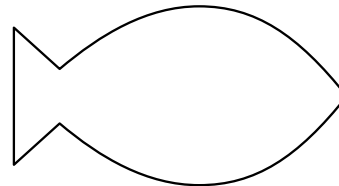
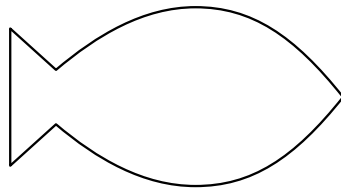

### Instructions

1. Remind the children that they are learning about obeying happily. Explain that they are going to get a chance to obey happily in this game.
2. Have the children form a circle around the "water."
3. Show the children the fishing pole and explain that each child will get a turn to go fishing. Demonstrate how to catch a fish using the pole. Explain that there is an instruction on each fish that they will have to follow.
4. Choose a child to go first. Help the child catch a fish. Read the fish to the child. Have the child obey the instruction written on the fish.
5. After each child's turn ask the group if the child obeyed happily. NOTE: If for some reason the child does not obey happily, give them a chance to do it again happily.
6. Give each child a turn.

### Conclusion

Demonstrate for the children the difference between obeying happily and unhappily. Unhappy: folded arms, hanging bottom lip, frown, etc. Happy: smile, say "okay," etc.

### Teacher Tips

- Be sure to write simple instructions for the children to follow.



## Noodle Necklace

The children will make a necklace to remind them of the memory verse.

### Materials

For each child:

- 1 piece of yarn, 30"
- 1 piece of red construction paper, 5" x 5"
- 6 pieces of ziti
- glue stick
- crayons or markers
- large beads (optional)

For the teacher:

- scissors
- hole punch
- masking tape

Reproducible Pages:

- Page F, one copy for every six children

### Preparation

1. Cut out the text boxes from the copies of Reproducible Page F.
2. Make a heart for each child as follows:
  - A. Cut a 5" x 5" piece of red construction paper and fold it in half.
  - B. Draw half a heart on the construction paper. See Figure A.
  - C. Cut out the heart being careful not to cut the folded edge.
3. Punch two holes in each heart. See Figure B.
4. Cut a 30" piece of yarn for each child.
5. Make a model of the craft following the instructions.

### Instructions

1. Show the children the model of the craft. Read the scripture to them and remind them of the story of Jonah. *God took care of Jonah and he takes care of us. God loves us and he will always love us, forever and ever!*
2. Give each child a memory verse and a heart. Have them glue the memory verse to the center of the heart.
3. Give each child a piece of yarn and tape one end to the table in front of the child.

4. Give each child six pieces of ziti. Have them thread three pieces of ziti onto the yarn.
5. Have the children thread the heart onto the yarn next.
6. Have them thread the last three pieces of ziti onto the yarn.
7. Untape the yarn from the table and tie the ends together.
8. Have the children color the pieces of ziti that are on their necklaces.
9. Help the children to write their names on the backs of their hearts.

### Teacher Tips

- Wrap a piece of tape around the end of the yarn to make it easier to thread.
- Add beads to make the necklace fancier.

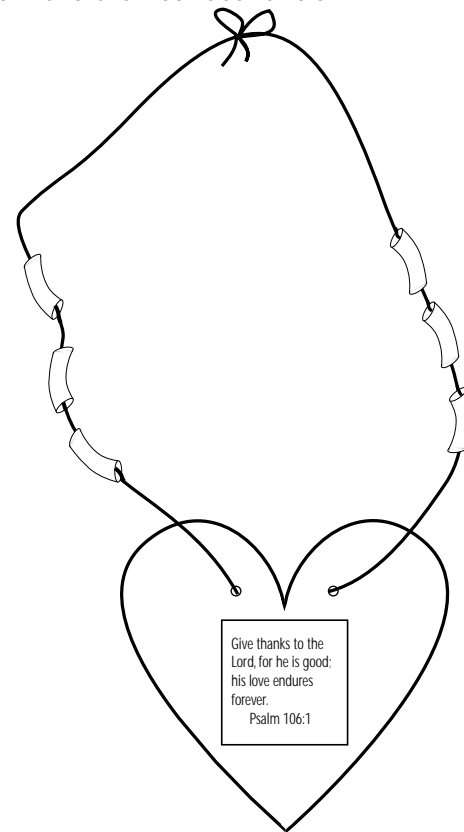

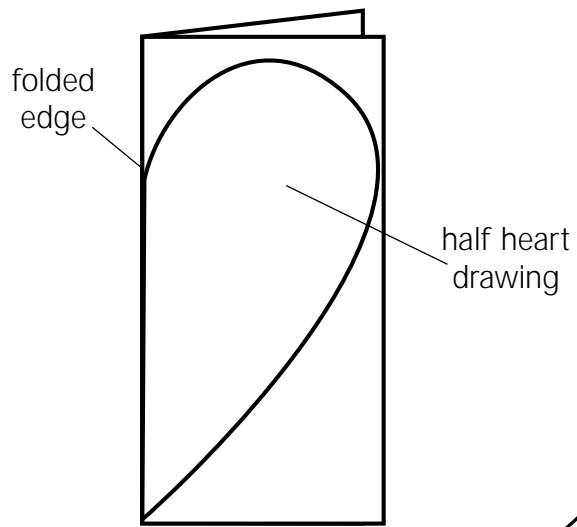

Figure A

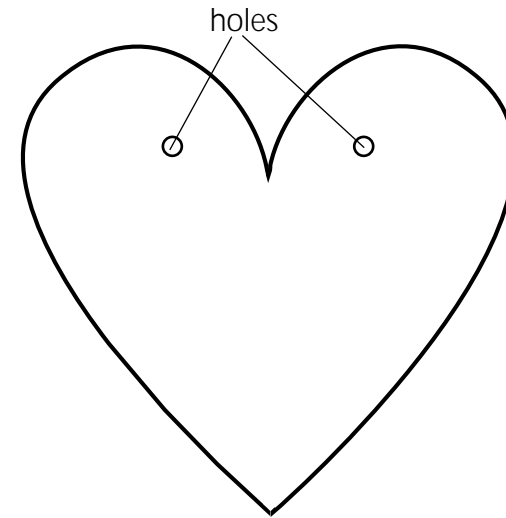
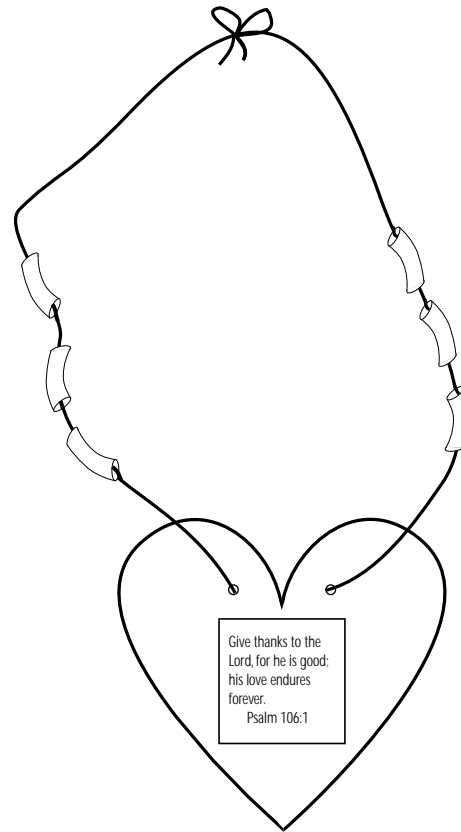

Figure B



Finished Craft

Give thanks to the  
 Lord, for he is good:  
 his love endures  
 forever.  
 Psalm 106:1





## Let's Pretend

The children will note the difference between obeying happily and unhappily.

### Scripture Memory Verse

Give thanks to the Lord for he is good; his love endures forever.  
Psalm 106:1

### Materials

*For the teacher:*

- scissors
- stapler
- a bag or a hat
- 1 piece of yellow construction paper

*Reproducible Pages:*

- Page A, 1 copy for the teacher

### Preparation

1. Cut out the commands from the copy of Reproducible Page A and put them in the bag.
2. Make a paper crown as follows, see Figure A:
  - A. Cut the yellow piece of construction paper in half making two 4½" x 12" pieces.
  - B. Cut one side of each piece so that it is jagged. See Figure A.
  - C. Staple the two pieces together.
  - D. Wrap the crown around your head and staple it so that it fits you.
3. Familiarize yourself with the activity.

### Instructions

1. Explain to the children that they are going to play a game called "Let's Pretend." Put the crown on your head. *Whoever is wearing the crown is the teacher. The teacher will choose a command action for me to do.*
2. Choose a child to go first. Put the crown on their head.
3. Have the child choose a command from the bag and tell you what to do.

4. Listen to the command and then, reluctantly follow the instructions.
5. Ask the children, *Did I obey happily?*
6. Have the child tell you the command again. This time obey happily.
7. Have the first child choose the next child to put on the crown and play the teacher.
8. Give each child a turn to be the teacher. Alternate between obeying happily and not obeying happily.

### Scripture Memory Activity

Put the crown on your head and recite the memory verse. Then place the crown on a child's head and have them say the verse. Have that child put the crown on another child's head for them to recite the verse. Continue until each child has had a turn.

### Conclusion

Encourage the children who have been bringing their friends to class. Explain to the children that when they obey happily it makes them happy and it makes people want to be their friends and learn about God.

Say a prayer with the children asking God to help you all to obey happily.

### Teacher Tips

- Have fun with this activity! Be very dramatic and animated to gain the children's attention. Over exaggerate your responses to give the children a clear picture of what it means to obey happily vs. unhappily.
- Be sure to help the children with the memory verse.

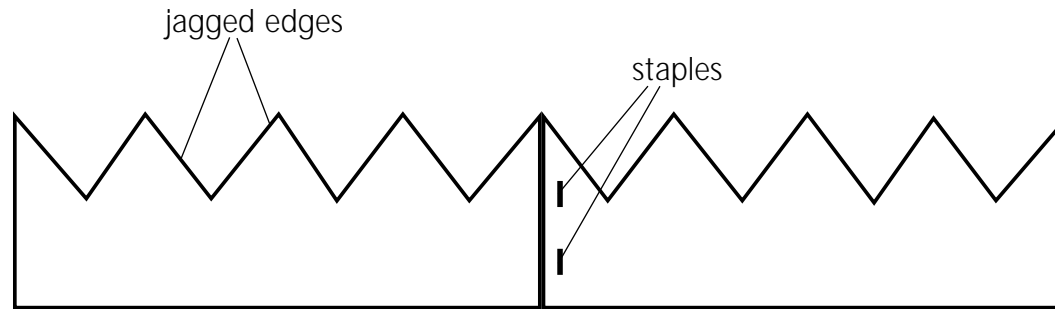

Figure A



Core/Supplement/Life Application

1 copy for the teacher

Read-Observe-Describe-Apply

Page

A



skipping

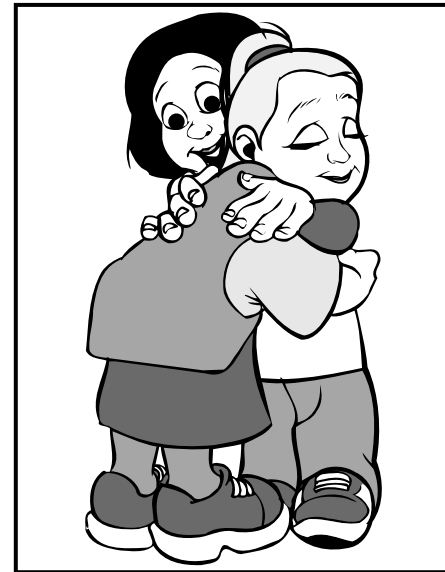

hugging



touching toes

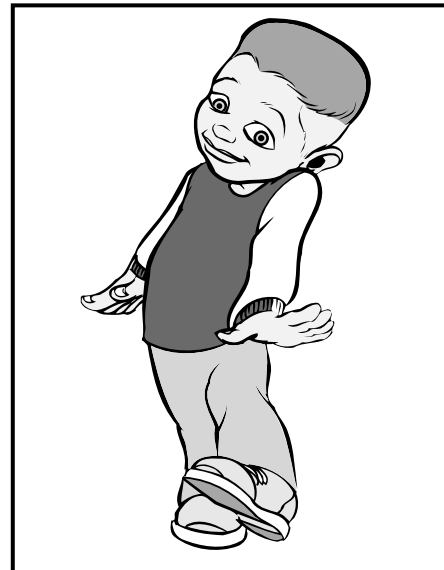

turning



blowing kisses

Core/Craft  
1 copy for the teacher

**B**e-b-neo-to-**B**e  
Page  
**B**

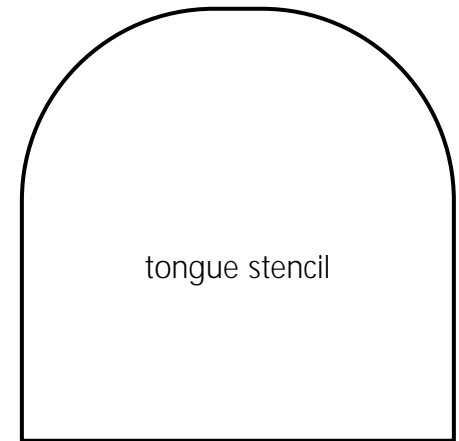
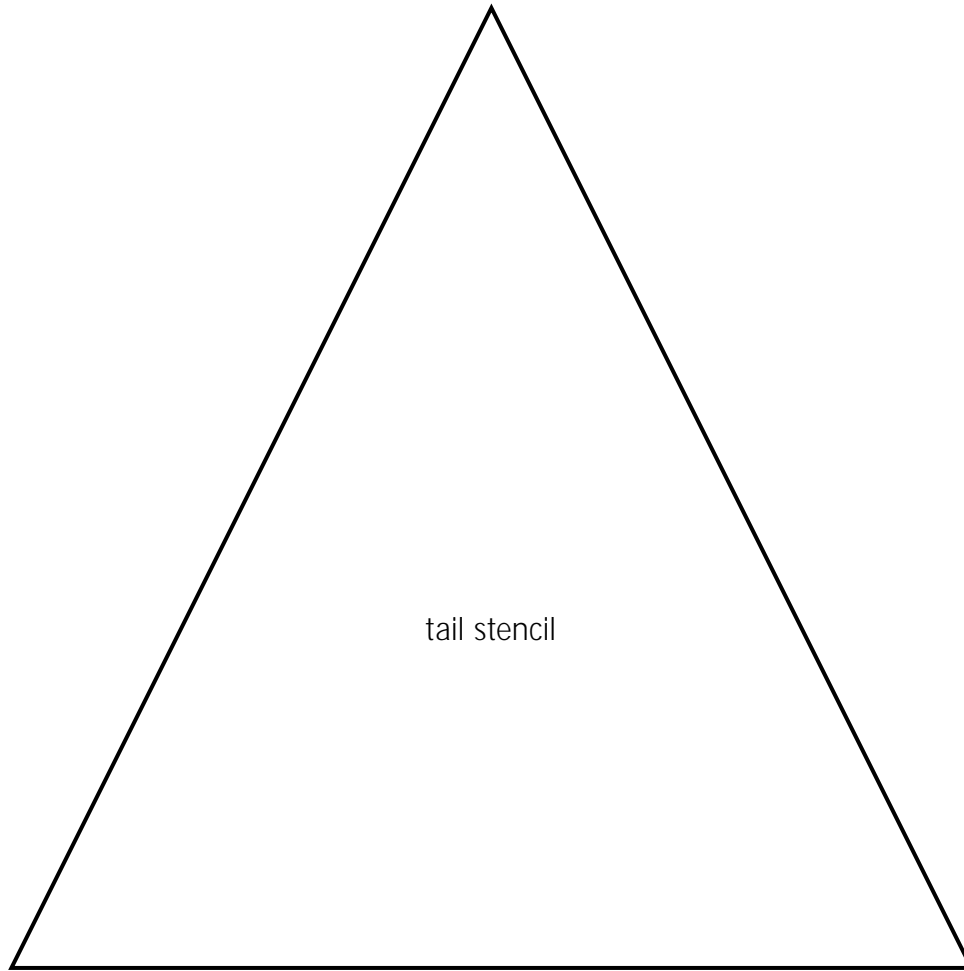



Core/Craft  
1 copy for every 5 children

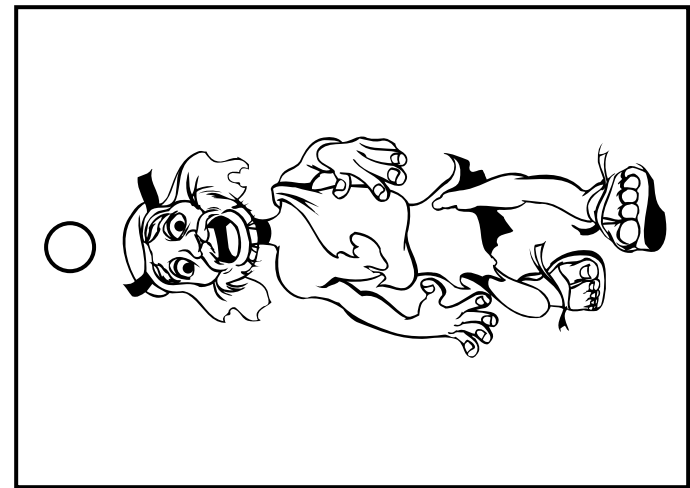
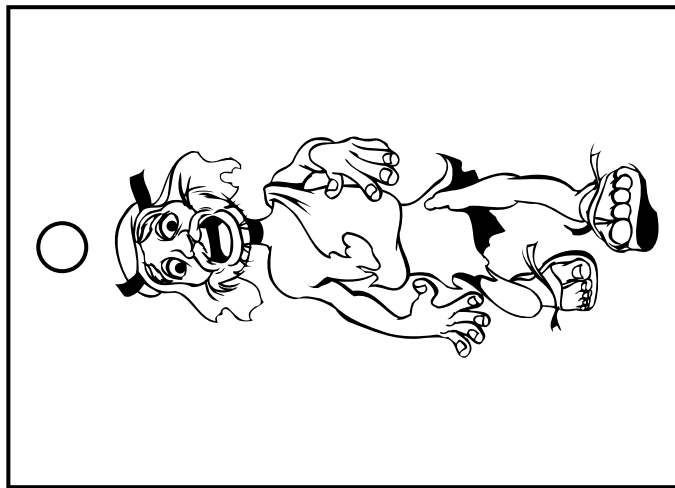



Supplement/Game

1 copy for the teacher

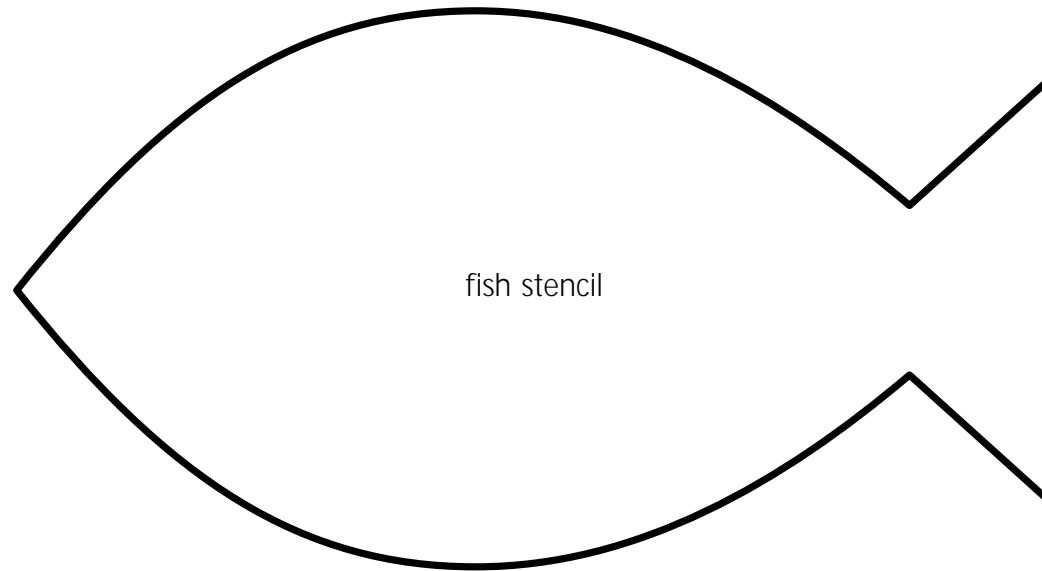

Pre-Occupied

Page

1



Supplement/Craft

1 copy for every six children

R  
A  
D  
I  
C  
A  
L  
S  
E  
R  
V  
I  
C  
E  
S

Page

F

Give thanks to the Lord, for he is good; his love endures forever. Psalm 106:1	Give thanks to the Lord, for he is good; his love endures forever. Psalm 106:1	Give thanks to the Lord, for he is good; his love endures forever. Psalm 106:1
Give thanks to the Lord, for he is good; his love endures forever. Psalm 106:1	Give thanks to the Lord, for he is good; his love endures forever. Psalm 106:1	Give thanks to the Lord, for he is good; his love endures forever. Psalm 106:1

