

Esther Obays

Lesson Objectives

- The children will describe Esther as a courageous and obedient woman.
- The children will practice working together as a team the way that Esther and Mordecai did.
- The children will discuss ways to be obedient even when it is difficult.

Lesson Text

Esther 4

Scripture Memory Verse

She continued to follow Mordecai's instructions as she had done when he was bringing her up.

Esther 2:20

Lesson Plan

Greeting and Registration

Preclass Activity: Obey Bag-1

Welcome and Singing

Centers:

Bible Story: Esther's Obedience

Life Application: Yes or No

Craft: Obey Bag-2

NOTE: Be sure to allow sufficient time for a snack.



Pre
class

A
C
H
I
V
I
T
Y

Esther Obeys

Obey Bag-1

The children will prepare materials for the craft.

Materials

For each child:

- envelope

For the teacher:

- magazines
- scissors

Preparation

1. Cut out pictures from magazines that reflect ways that the children can obey. Choose small pictures, about 2" x 3".



Instructions

1. Explain to the children that today's Bible Story is about Esther obeying. Discuss obedience briefly with the children, e.g.: sometimes it is hard to obey but we feel happy when we do. Show them a magazine picture that shows obedience. Explain to them why the picture would remind you to be obedient.
2. Have the children choose five pictures that would help them remember to be obedient. Talk to the children about the pictures they chose.
3. Have the children place their pictures in an envelope and write their name on the envelope.
4. Give the envelopes to the Craft teacher.

Teacher Tips

- Have the children cut out extra pictures for children who arrive late.

Esther Obeys

Esther's Obedience

The children will learn of Esther's obedience and bravery.

Lesson Text

Esther 4

Materials

For the teacher:

- felt board
- felt board figures from the Unit 19 Lesson 3, Bible Story
- material scraps that look torn or have holes in them
- crayons
- scissors

Reproducible Pages:

- Page A, 1 copy for the teacher

Preparation

1. Cut out and color the Hathach figure and the dirty clothes from the copy of Reproducible Page A.
2. Roll a piece of tape to place on the back of each figure.
3. Familiarize yourself with the story.

Courage and Obedience

Have the children sit in a circle. *Who remembers the name of the young woman that we learned about last week? She became a queen. Yes, we learned about Esther.* Put Esther on the board. *Who remembers the name of her older cousin who raised her? Yes it was Mordecai.* Put Mordecai on the board. *Mordecai and Esther were Jews. The Jews were God's people.*

After Esther had been queen for a while something sad happened. One of the King's men named Haman did not love God at all. He didn't like the Jews either and he wanted to get rid of them. He convinced the King to sign a letter saying that he could kill all of the Jews.

The King and Haman did not know that Esther was a Jew. Take down Mordecai and put up the King. The king loved and trusted Esther because she was loving and obedient. But he did not know that she was that way because she loved God.

When Mordecai heard about the letter to kill all the Jews he and all of the Jewish people cried and were very sad. Take down the King and Mordecai figures. They put on old, torn clothes to show how sad they were. Put the old torn clothes on Mordecai. And they prayed and cried out to God for many days (Esther 4:1-5).

Put Esther on the felt board. *When Esther was told that Mordecai was sad and was wearing dirty, old clothes, she sent some clothes to him but he would not put them on. She sent her servant Hathach and told him to find out what was wrong (Esther 4:4-5).* Put up the Hathach figure.

Mordecai told Hathach what was going to happen to the Jewish people. He told Hathach to have Esther go to the King and ask him to save the people (Esther 4:6-8).

Esther was scared to go to the King. If she went in to see the king and he didn't want to see her, then the law said that he could kill her (Esther 4:10-11). Wow, that's scary!

What do you think Esther did? Remove Hathach and Mordecai from the board. Was she selfish or courageous? Did she obey her cousin even though she was scared? Yes, she obeyed. She went to the King. Because she was so brave God blessed her and the King saved the Jewish people!

Conclusion

Ask the following questions as a review:

- Who was Esther? (a Jewish queen)
- Who was Mordecai? (Esther's cousin)
- Why was Mordecai sad? (because the Jews were going to be killed)
- What did Esther do to save her people? (she went to the King, was obedient, was brave)

Teacher Tips

- Be sure to familiarize yourself with the story and tell it to the children with feeling. Rehearse it before the class so that you don't have to read it to them.



Esther Obeys

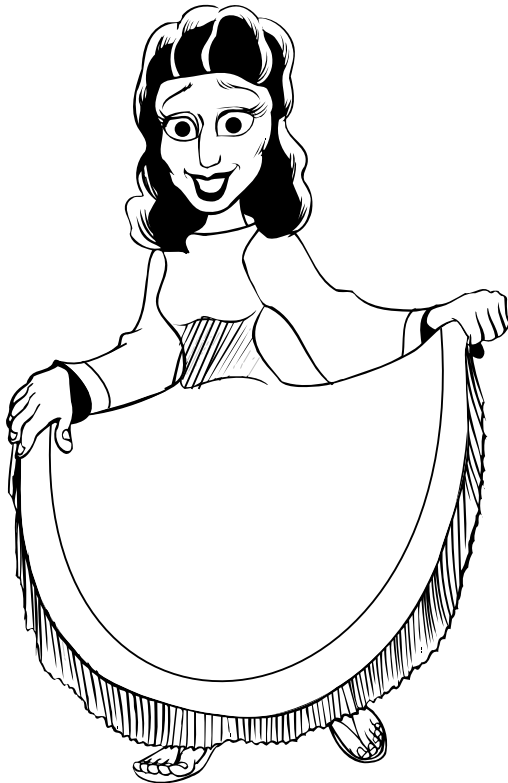

Yes or No

Through the interaction of puppets, the children will list things that keep them from obeying and then pray about them.

Scripture Memory Verse

She continued to follow Mordecai's instructions as she had done when he was bringing her up.

Esther 2:20

Materials

For the teacher:

- 2 craft sticks
- glue
- scissors

Reproducible Pages:

- Page B, 1 copy for the teacher

Preparation

1. Cut out and color the puppets from the copy of Reproducible Page B.
2. Glue each puppet onto a craft stick.
3. Familiarize yourself with the text so that you won't have to read it to the children.

Instructions

Introduce the two puppets to the children. *Do you remember these puppets? This is Whiney Weasel and this is Wise Owl. Can you say hello?* Have the children say hello.

WEASEL: (whining) *I don't want to say hello. I'm scared.*

TEACHER: *Why are you scared? These children are your friends. Please say hello to them.*

WEASEL: *No, I don't want to.*

TEACHER: *Children, do you ever feel this way? Do you get scared to say hello to new friends? Have the children respond. Is Weasel being obedient? No, he's not. Weasel, you can trust me, these children won't hurt you. They want to be your friends. Please don't be selfish. Say hello to them.*

WEASEL: *I'm sorry, hello children.*

TEACHER: *Weasel and Owl are going to act out some situations for you where one of them is obeying and the other isn't. They will need your help to figure out what to do.*

OWL: *Weasel, the teacher said it is time to clean up the toys so we can start class.*

WEASEL: *I know but I don't want to, I just want to finish playing with this castle I'm building.*

TEACHER: *Is Weasel obeying? No. What should he do? Yes, he should be like Esther and obey. He should pick up the toys right away and join the class. He will be able to play with the blocks again later.*

WEASEL: *I'm sorry, I'll pick up the blocks right away.*

WEASEL: *Owl, it's time to listen to the Bible Story. Stop talking and playing around.*

OWL: (looking around, not paying attention to the story or to Weasel)

TEACHER: *Is Owl being obedient and considerate? No, he's thinking of himself and what he wants to do. That's making it hard for everyone else to pay attention.*

OWL: *I'm sorry, I'll pay attention. I love hearing Bible stories.*

TEACHER: *Sometimes it can be hard to obey. When is it hard for you to obey? Discuss this question with the children. Offer scenarios that apply to them to help them think of when it might be hard to obey. Is it hard for you to obey when your mother tells you to eat some food that you don't like? Is it hard for you to obey when it's time to clean up?*

Scripture Memory Activity

Have the children teach the memory verse to the puppets.

Conclusion

Encourage the children in the group who have been bringing friends with them to Bible class.

Pray with the children to be obedient. Pray that you can all help your friends to come to church and learn about God.

Teacher Tips

- Use your own scenarios from your classroom to help your children to be obedient. Keep it positive.



Esther Obeys

Life

A
P
P
L
I
C
A
T
I
O
N

She continued to follow
Mordecai's instructions as
she had done when he
was bringing her up.

Esther 2:20



Esther Obeys

Obey Bag-2

The children will make a purse to help them remember to be obedient.

Materials

For each child:

- 1 piece of poster board, 9" x 12"
- yarn, 40"
- glue stick
- envelopes from the Preclass Activity
- decorative items such as beads, buttons, foil, scraps of colored paper or material

For the teacher:

- hole punch
- scissors
- ruler

Reproducible Pages:

- Page C, 1 copy for every six children

Preparation

1. Cut out the text boxes from the copies of Reproducible Page C.
2. Cut a 40" piece of yarn for each child.
3. Prepare a purse for each child as follows:
 - A. Fold each piece of poster board in half. See Figure A.
 - B. Draw a half oval on the folded piece of poster board and cut it out as a "bag." NOTE: Be sure not to cut the folded edge. See Figure B.
 - C. Fold down one side of the bag. See Figure C.
 - D. Punch holes around the edges of each bag.
4. Make a model following the instructions.

Instructions

1. Give each child a bag and a piece of yarn.
2. Have them thread the yarn through the holes and help them tie the ends together.
3. Give each child a text box to glue onto the flap of their bag.
4. Give each child their envelope from the Preclass Activity.
5. Have the children glue the pictures onto their bags.
6. Have them color and decorate their bags with decorative items and help them to write their name on it.

Teacher Tips

- Number the holes so the children can lace the yarn through them in order.
- Do not punch holes in the folded flap of the purse.

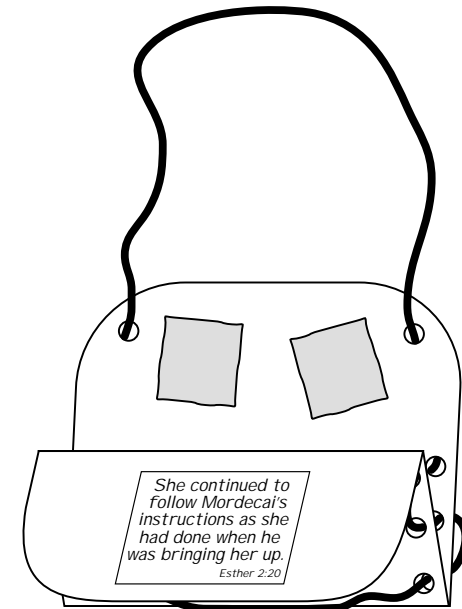

Esther Obeys

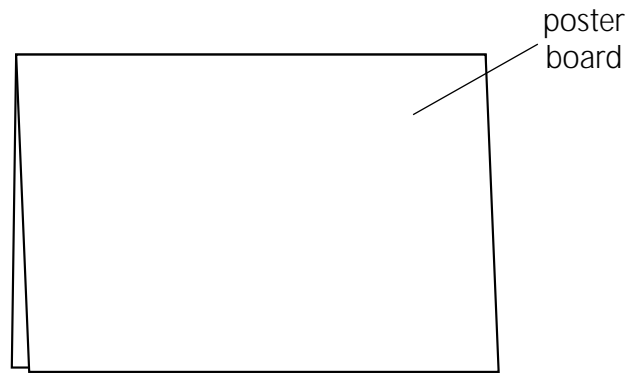

Figure A

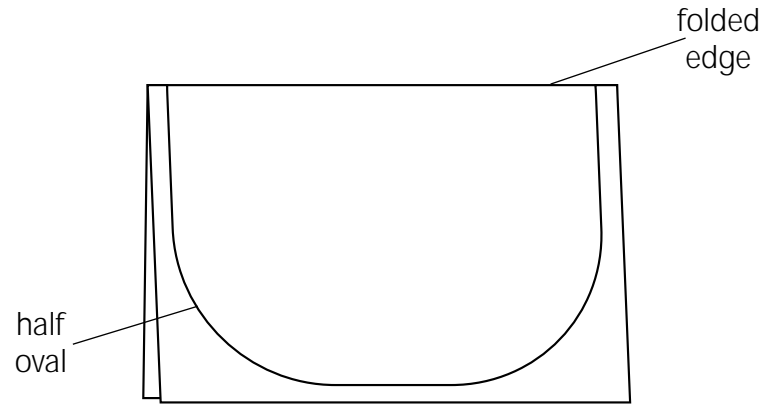

Figure B

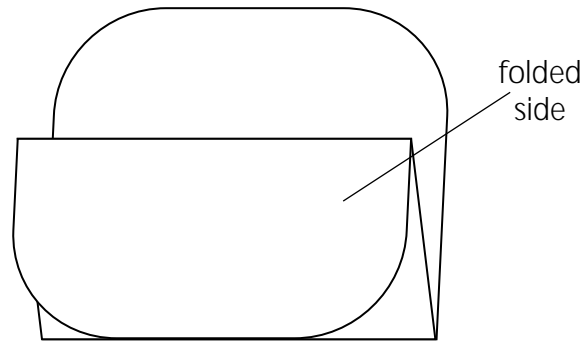
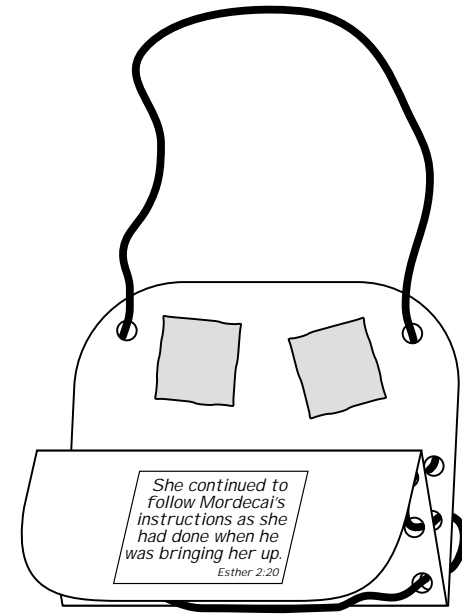

Figure C



Finished Craft



Esther Obeys

Lesson Objectives

- The children will describe Esther as a courageous woman who was obedient.
- The children will practice working together as a team the way that Esther and Mordecai did.
- The children will discuss ways to be obedient even when it is difficult.

Lesson Text

Esther 4

Scripture Memory Verse

She continued to follow Mordecai's instructions as she had done when he was bringing her up.

Esther 2:20

My Room-1

The children will begin to make the craft.

Materials

For each child:

- shoe box or other small box
- 3 pieces of construction paper
- scissors
- markers or crayons

Preparation

When class begins, borrow the craft model from the Craft teacher.

Instructions

1. Explain that in the Bible Story they have been learning about Esther. Esther was a woman who obeyed God and the people that God put in her life such as her cousin Mordecai. Show the children the model box. Explain what room it is and why the Craft teacher decided to make this room. *You are going to make a room as well. It can be any room where there are lots of other children and where you can be like Esther and be obedient.* Ask the children to help you think of ideas of different rooms that they could make: bedroom, classroom, mall, store, library, etc.

Lesson Plan

Greeting and Registration

Preclass Activity: My Room-1

Welcome and Singing

Centers:

Game: Through the Pipe

Craft: My Room-2

Life Application: Yes or No

NOTE: Be sure to allow sufficient time for a snack.

2. Give each child a box and some construction paper. Have them draw a picture of a room on the paper and cut it to fit inside the box. Have them glue the paper in the box.
3. Put the children's names on their boxes and give them to the Craft teacher.

Teacher Tips

- Encourage the children as they work. Help them to be creative in their thinking. Be sure to explain that they will be able to work on their box more in the Craft center.



Through the Pipe

The children will pass a felt or yarn ball through cylinders together to practice working as a team.

Materials

For each child:

- paper towel tube

For the teacher:

- a small ball of yarn, 1" diameter

Preparation

Familiarize yourself with the game.

Instructions

1. *In our Bible Story we learned that Esther listened to Mordecai and because they worked together their people were saved. It is very important for us to learn to listen to each other and to work together.*
2. Give each child a tube.
3. Have the children sit or stand in a straight line. Tell them to hold up their tubes and connect them end to end with the tube next to them making one long tube.
4. Give the child at the beginning of the line a ball of yarn. When you say "Go!" have the child put the ball into their pipe. They must let the ball slide to the end of their tube and into the next player's tube. Then that child must let the ball slide to the end of his tube to the next player's tube, etc. If the ball drops to the floor, the last person must pick it up and try again. They can only pass the ball from one tube to the other.
5. Have them play again.

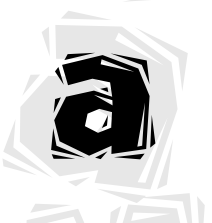

Conclusion

Encourage the children as they work together as a team.

Teacher Tips

- Divide the children into even teams and play again.
- Cover the tubes with construction paper to make them more colorful.



CRAFT

My Room-2

The children will create the scene where they can be like Esther and obey even if no one else obeys.

Materials

For each child:

- construction paper
- box from the Preclass Activity
- markers or crayons
- glue stick or tape

For the teacher:

- cardboard pieces
- decorative materials: craft sticks, spools, egg cartons, sequins, etc.
- magazines
- scissors

Reproducible Pages:

- Page C, 1 copy for every six children

Preparation

1. Cut pictures of people, furniture, food, classrooms, etc. from magazines
2. Cut out the text boxes from the copies of Reproducible Page C.
3. Make a model of the craft following the instructions. NOTE: In the Preclass Activity the children used construction paper to begin creating their room by drawing a picture.

Instructions

1. Give each child their box from the Preclass Activity. Have them create their rooms with the materials and the magazine pictures you provide. Help them to think of things that would be in their rooms and ways that they can make these items.
2. Give each child a text box to glue onto their craft.
3. Have each child draw a picture of themselves happily obeying and then glue it in the scene.

Esther Obeys

Heroes of Old

Lesson 4

Conclusion

Have the children share about their rooms. Ask them some questions about their room. Why did they pick that room? How can they be a great example of obedience there?

Teacher Tips

- Be sure to explain the craft to the children's parents. Tell them that their child learned about Esther's example of obedience and that this craft is an example of a place where the child thinks he can be a great example of obedience.

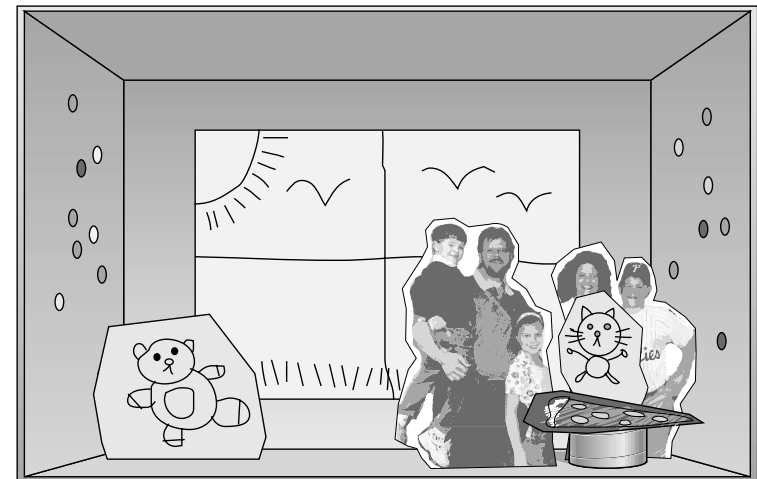

supplement

CRAFT

Esther Obeys

Heroes of Old

Lesson 4

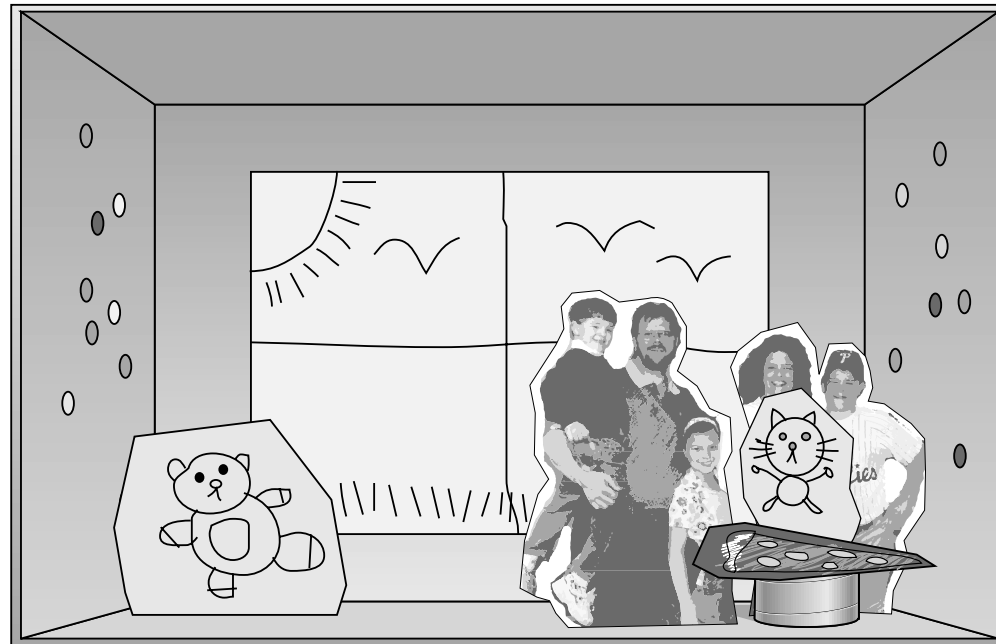

Finished Craft



Summer 2

© 2000 by Discipleship Publications International

Heroes of Old 19-4-12



Yes or No

Through the interaction of puppets, the children will list things that keep them from obeying and then pray about them.

Scripture Memory Verse

She continued to follow Mordecai's instructions as she had done when he was bringing her up.

Esther 2:20

Materials

For the teacher:

- 2 craft sticks
- glue
- scissors

Reproducible Pages:

- Page B, 1 copy for the teacher

Preparation

1. Cut out and color the puppets from the copy of Reproducible Page B.
2. Glue each puppet onto a craft stick.
3. Familiarize yourself with the text so that you won't have to read it to the children.

Instructions

Introduce the two puppets to the children. *Do you remember these puppets? This is Whiney Weasel and this is Wise Owl. Can you say hello?* Have the children say hello.

WEASEL: (whining) *I don't want to say hello. I'm scared.*

TEACHER: *Why are you scared? These children are your friends. Please say hello to them.*

WEASEL: *No, I don't want to.*

TEACHER: *Children, do you ever feel this way? Do you get scared to say hello to new friends? Have the children respond. Is Weasel being obedient? No, he's not. Weasel, you can trust me, these children won't hurt you. They want to be your friends. Please don't be selfish. Say hello to them.*

WEASEL: *I'm sorry, hello children.*

Esther Obeys

Heroes of Old

Lesson 4

TEACHER: *Weasel and Owl are going to act out some situations for you where one of them is obeying and the other isn't.*

They will need your help to figure out what to do.

OWL: *Weasel, the teacher said it is time to clean up the toys so we can start class.*

WEASEL: *I know but I don't want to, I just want to finish playing with this castle I'm building.*

TEACHER: *Is Weasel obeying? No. What should he do? Yes, he should be like Esther and obey. He should pick up the toys right away and join the class. He will be able to play with the blocks again later.*

WEASEL: *I'm sorry, I'll pick up the blocks right away.*

WEASEL: *Owl, it's time to listen to the Bible Story. Stop talking and playing around.*

OWL: (looking around, not paying attention to the story or to Weasel)

TEACHER: *Is Owl being obedient and considerate? No, he's thinking of himself and what he wants to do. That's making it hard for everyone else to pay attention.*

OWL: *I'm sorry, I'll pay attention. I love hearing Bible stories.*

TEACHER: *Sometimes it can be hard to obey. When is it hard for you to obey? Discuss this question with the children. Offer scenarios that apply to them to help them think of when it might be hard to obey. Is it hard for you to obey when your mother tells you to eat some food that you don't like? Is it hard for you to obey when it's time to clean up?*

Scripture Memory Activity

Have the children teach the memory verse to the puppets.

Conclusion

Encourage the children in the group who have been bringing friends with them to Bible class.

Pray with the children to be obedient. Pray that you can all help your friends to come to church and learn about God.

Teacher Tips

- Use your own scenarios from your classroom to help your children to be obedient. Keep it positive.

She continued to follow
Mordecai's instructions as
she had done when he
was bringing her up.

Esther 2:20



Core/Bible Story

1 copy for the teacher

Read-Observe-Describe-Apply

Page

A



Hathach

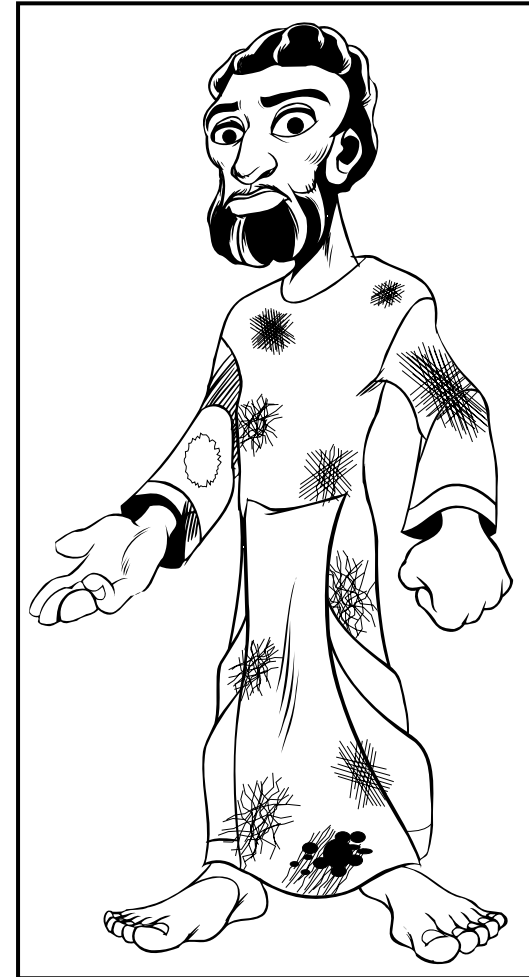

Mordecai with dirty clothes



Core/Supplement/Life Application
1 copy for the teacher

Read-Observe-Do

Page

B



Whiney Weasel



Wise Owl



Core/Supplement/Craft

1 copy for every six children

READ-OBED-CE

Page

C

<p>She continued to follow Mordecai's instructions as she had done when he was bringing her up.</p> <p>Esther 2:20</p>	<p>She continued to follow Mordecai's instructions as she had done when he was bringing her up.</p> <p>Esther 2:20</p>
<p>She continued to follow Mordecai's instructions as she had done when he was bringing her up.</p> <p>Esther 2:20</p>	<p>She continued to follow Mordecai's instructions as she had done when he was bringing her up.</p> <p>Esther 2:20</p>
<p>She continued to follow Mordecai's instructions as she had done when he was bringing her up.</p> <p>Esther 2:20</p>	<p>She continued to follow Mordecai's instructions as she had done when he was bringing her up.</p> <p>Esther 2:20</p>

