

Nehemiah's Heart

Lesson Objectives

- The children will state that Nehemiah apologized to God when he realized that he and his friends hurt God.
- The children will explain why God was not happy.
- The children will practice apologizing and forgiving others.

Lesson Text

Nehemiah 1:1- 2:8

Scripture Memory Verse

Trust in the Lord and do good.

Psalm 37:3

Lesson Plan

Greeting and Registration

Preclass Activity: Broken Walls

Welcome and Singing

Centers:

Bible Story: Nehemiah Says He Is Sorry

Life Application: Sorry!

Craft: Forgive Me Box

NOTE: Be sure to allow sufficient time for a snack.



Nehemiah's Heart

Broken Walls

The children will create the scene to be used in the Bible Story.

Materials

For each child:

- 1 piece of dark-colored construction paper
- glue stick

For the teacher:

- poster board or banner paper
- marker
- large bowl or container

Preparation

Draw buildings on the poster board that look like old Jerusalem. See Figure A.

Instructions

1. Have the children rip the construction paper into small pieces and place them in the bowl.
2. Have the children glue the ripped pieces of construction paper onto the poster board as a broken wall around the buildings.
3. Give the poster board picture to the Bible Story teacher.

Conclusion

Explain to the children that they have made a picture of the wall around Jerusalem. That it was broken down and burned and that they are going to hear a story of a man who loved God and wanted to rebuild the wall.

Teacher Tips

- If you do not use banner paper use two large pieces of poster board so all of the children can be involved.

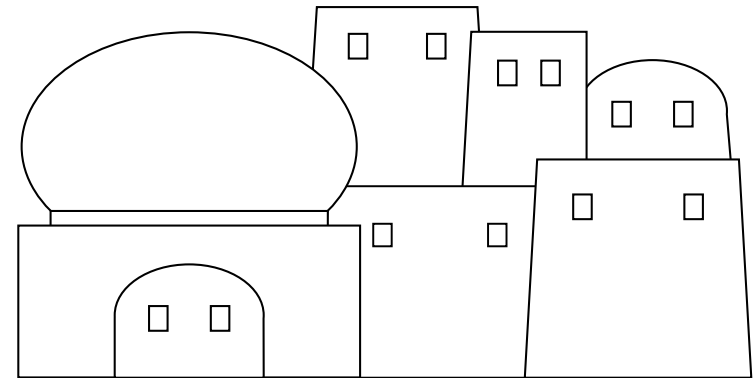

Figure A

Nehemiah's Heart

Nehemiah Says He Is Sorry

The children will hear the story of Nehemiah.

Lesson Text

Nehemiah 1:1-2:8

Materials

For the teacher:

- picture from the Preclass Activity
- robe and scarf, to dress like Nehemiah

Preparation

1. Familiarize yourself with the story.
2. Dress as Nehemiah.

Instructions

Open the Bible and place it in your lap. *Hi boys and girls, my name is Nehemiah. Can you say that? Great! I'm here to tell you some things about myself that helped me to love God more. It's always good to learn how to love God more.*

A long time ago my people, the Jews, and I were living in a foreign land. We had been living in our land, a place called Judah that God had given to us. But we did not listen to God. We were not obedient to him so he sent us away to a foreign land.

I was working as a servant in a king's home. I was the one who served the king whatever he wanted to drink. I was called the cup bearer because I was always carrying cups of something for the king to drink.

One day, a friend came to me from my homeland, Judah. I was so happy to see him. I had so many questions for him (Nehemiah 1:1-2). Do you ever ask someone a lot of questions? I wanted to know how Jerusalem was, that's the big city in Judah.

My friend told me some bad news. He told me that the wall around Jerusalem was broken down and that its gates had been burned (Nehemiah 1:3). It probably looked something like this picture that you made. Point to the picture.

Do you know how I felt when I heard this news? Let the children respond. I felt so sad that all I could do was sit down and cry (Nehemiah 1:4). Why do you think I was crying? Let the children respond. I was crying because I knew that God was very sad that the city he gave us was ruined. God was very sad because we stopped listening to him and obeying him. I was sad because we hurt God very much.

So I prayed to God. First, I talked to God about how great and powerful he is. I told him that I know he keeps his promises to the people who love and obey him. I know he loves all people. Then, I asked him to forgive me and all of my people for not obeying him (Nehemiah 1:5-10). I also asked him to be with me when I went to the king to ask for help to rebuild the wall around Jerusalem.

God heard my prayer and he answered it. When I went to the king he gave me all of the help that I would need and I was able to return to Jerusalem and rebuild the wall! I helped God's people to love and obey him again and God was happy.

Conclusion

Ask the children the following questions as a review:

- What did the people do that made God sad? (stopped listening to him, disobeyed him)
- How did Nehemiah feel when he heard that the city was in ruins? (sad)
- What did Nehemiah do when he heard about the city? (cried, prayed)
- What did Nehemiah say to God in his prayer? (asked for forgiveness and for help when he went to the king)
- Did God answer Nehemiah's prayer? (yes)

Teacher Tips

- Be sure that you tell the children the story with lots of energy. Don't just read it to them.



Nehemiah's Heart



Nehemiah's Heart

Sorry!

The children will be reminded of Nehemiah's heart before God when they "spell" out the word sorry.

Scripture Memory Verse

Trust in the Lord and do good.

Psalm 37:3

Materials

For each child:

- a magazine or pages from magazines
- glue stick
- scissors

For the teacher:

- 5 pieces of poster board
- wide-tipped marker
- silver, orange, yellow and red crayons

Preparation

Spell out the word sorry by writing one large letter on each piece of poster board.

Instructions

1. Have the children sit in a circle. Spread the poster board letters on the floor in the correct order. *Does anyone know what word these letters spell? Yes, it is the word "sorry." That is what Nehemiah said to God when he learned that he and his people had hurt God. He prayed and told God he was sorry. If we hurt God or someone else how would it make them feel if we told them we were sorry? Yes, it makes them happy again.*
2. Divide the children into groups of two or four.

3. Show the children the first poster board with the letter S. Explain that the color silver starts with S. Ask the children to show you what the color silver looks like using the silver crayon as an example.
4. Give each group a magazine and have them cut or rip out pictures with the color silver in them.
5. Have the children glue the pictures onto the S poster board around the letter.
6. Have the children repeat this with each letter cutting out pictures of orange things for the O, red things for the R's and yellow things for the Y.

Scripture Memory Activity

Keep the children in their groups. Have them work in the group to practice the memory verse. Have them choose one person from the group to recite the verse.

Conclusion

Encourage the children to be quick to say that they are sorry when they are playing with others and at home, even if something was an accident. Ask them how it would make God and the person feel if they apologized.

Pray with the children about being quick to say they are sorry. Pray that they can bring their friends with them to Bible Class.

Teacher Tips

- Praise the children that are working together.

SORRY

Nehemiah's Heart

Life

A
P
P
L
I
C
A
T
I
O
N

Trust in the LORD
and do good.

Psalm 37:3



Nehemiah's Heart

Forgive Me Box

The children will make a pop-up box to express that they are sorry when they hurt someone.

Materials

For each child:

- 1 piece of red construction paper, 2" x 3"
- 1 piece of construction paper, 1" x 7"
- 1 small cardboard jewelry box
- glue stick
- tape
- markers or crayons
- decorative materials: stickers, scrap pieces of felt, material, etc.

For the teacher:

- scissors
- pencil

Reproducible Pages:

- Page A, 1 copy for every 6 children

Preparation

1. Cut out the text boxes from the copies of Reproducible Page A.
2. Cut out one of the heart stencils from a copy of Reproducible Page A.
3. Trace and cut out one heart for each child from red construction paper.
4. Write "I forgive you." on each heart.
5. Cut a 1" x 7" piece of construction paper for each child.
6. Make a model of the craft following the instructions.

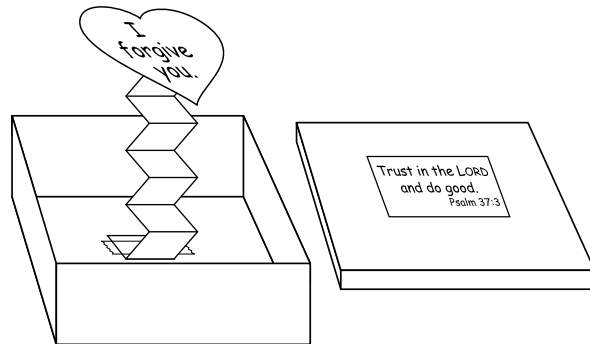

Instructions

1. Show the children the model of the craft. *In our story today we are learning about Nehemiah. Nehemiah was a man who loved God very much. When he discovered how sad God was about his sin and the sin of all of his people, Nehemiah cried out to God and said he was sorry. It is very good to say you're sorry if you hurt someone. If someone says they are sorry to you what should you say? Open the box and show the children the heart. You should tell them that you forgive them. That is what this heart says, I forgive you.*
2. Give each child a jewelry box and a text box. Have them glue the text box on the cover of the jewelry box and then color and decorate the box.
3. Give each child a 1" x 7" piece of paper. Have them fold the paper accordion style to make a "spring." See Figure A.
4. Give each child a heart to tape onto one end of the folded paper. See Figure B.
5. Help each child to tape the other end of the folded paper to the inside, bottom of the box.
6. Write the children's names on their crafts.

Conclusion

Have the children put the covers back on the boxes. Have them practice saying "I'm sorry." to each other and then opening their boxes and saying "I forgive you."

Teacher Tips

- Small jewelry boxes can be found at craft stores or at department store jewelry counters. Many jewelry departments will give them to you for free if they know that you're going to use them for a children's church activity.

CRAFT

Nehemiah's Heart

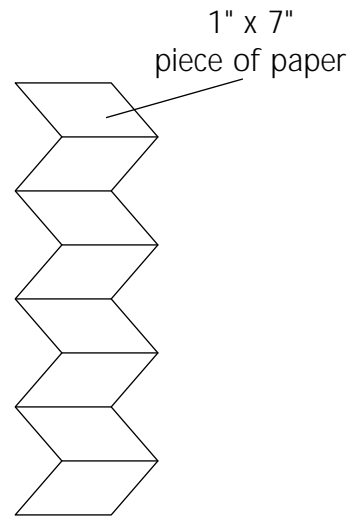

Figure A

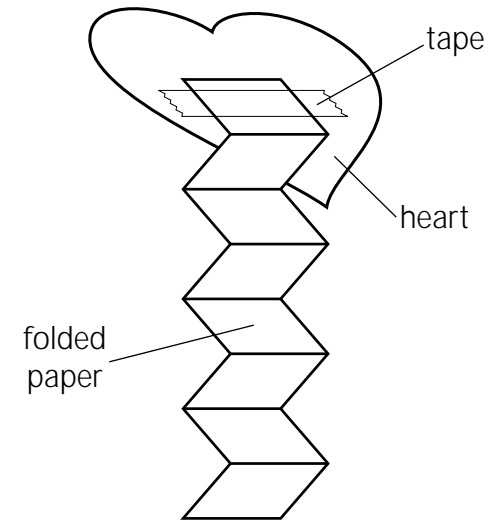
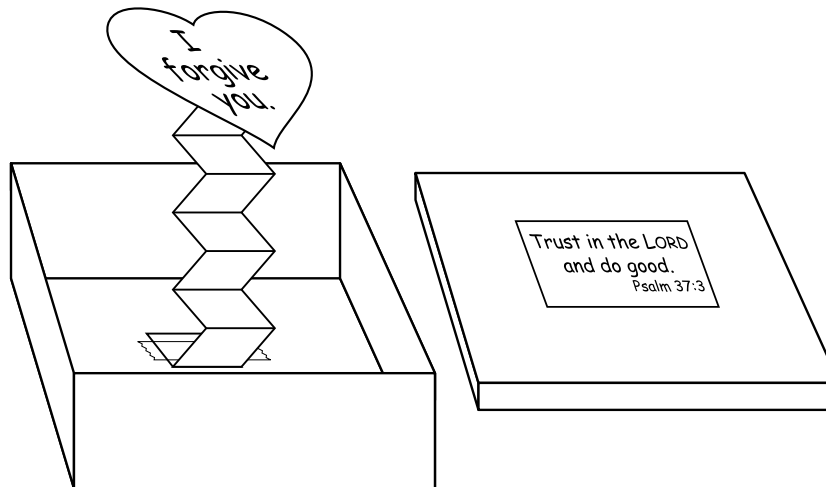

Figure B



Finished Craft





Pre class



Nehemiah's Heart

Lesson Objectives

- The children will state that Nehemiah apologized to God when he realized that he and his friends hurt God.
- The children will explain why God was not happy.
- The children will practice apologizing and forgiving others.

Lesson Text

Nehemiah 1:1-2:8

Scripture Memory Verse

Trust in the Lord and do good.

Psalm 37:3

Puppet Cut-Outs

The children will make puppet cut-outs for the Craft Center.

Materials

For each child:

- 2 pieces of construction paper, 3" x 4"
- scissors
- glue stick
- markers or crayons
- 1 envelope

For the teacher:

- paper
- pencil or pen
- ruler
- scissors

Reproducible Pages:

- Page B, 1 copy for every 5 children

Lesson Plan

Greeting and Registration

Preclass Activity: Puppet Cut-Outs

Welcome and Singing

Centers:

Game: S-O-R-R-Y

Craft: Forgiving Friends

Life Application: Sorry!

NOTE: Be sure to allow sufficient time for a snack.

Preparation

1. Fold two, 3" x 4" pieces of construction paper in half for each child so they are 1½" x 4".
2. Measure each piece ½" along the fold and 1" along the bottom and mark these cut lines as shown in Figure A.
3. Cut out the text boxes from the copies of Reproducible Page B.
4. Make a model for the children following the instructions.

Instructions

1. Give each child two folded and marked pieces of construction paper. Have them cut the paper on the lines.
2. Have the children open the cutouts and fold the bottom portions in half towards the backs of the cut-outs. See Figure B.

3. Give each child two text boxes to glue onto the fronts of the folded portions of the cut-outs.
4. Have the children put their puppet cut-outs into an envelope. Put their names on the envelopes.
5. Give the envelopes to the Craft teacher.

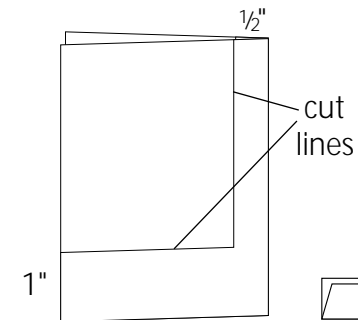

Figure A

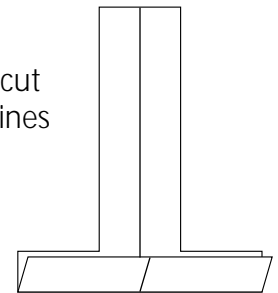

Figure B



S-D-R-R-Y

The children will play a card game and be reminded of how Nehemiah apologized to God.

Materials

For the teacher:

- 20 pieces of construction paper, 2" x 3"
- scissors
- marker

Preparation

1. Cut twenty 2" x 3" pieces of construction paper for each child as cards.
2. Spell out the word sorry by writing one letter on each card.
3. Repeat this three more times until you have four cards of each letter.



Instructions

1. Place one set of cards face up spelling the word sorry in front of the children.
2. *Does anyone know what this word spells? Yes, it spells the word "sorry." When Nehemiah learned how sad he and his friends made God feel, he prayed and told God he was sorry. If we hurt God or a person how does it make them feel if we say that we are sorry? Yes, it makes them happy again. Let's play a card game and try to choose matching letters to make a pair.*
3. Mix up all the cards and place them face down in five or six rows.
4. Have each child take a turn and turn over two cards one at a time to try to match the letters.
5. If the cards match the child keeps the pair. If they do not match the child turns them face down and the next child takes a turn.
6. Continue until all of the cards are matched.
7. Play the game again as time allows.

Teacher Tips

Play the game along with the children.

SORRY





Nehemiah's Heart

Forgiving Friends

The children will make puppets. They will share what they learned about Nehemiah and practice forgiving each other.

Materials

For each child:

- envelopes from the Preclass Activity
- 1 piece of poster board, 9" x 12"
- 1 piece of brown construction paper
- crayons
- glue stick

For the teacher:

- scissors
- tape

Reproducible Pages:

- Page C, 1 copy for every 6 children

Preparation

1. Cut out the puppet figures from the copies of Reproducible Page C.
2. Make a model of the craft following the instructions.

Instructions

1. Show the children the model of the craft. Remind them of Nehemiah who apologized to God. God helped him to rebuild the wall around his city. Remind them of the king who God used to help Nehemiah after he prayed.
2. Give each child their envelopes from the Preclass Activity and a Nehemiah puppet figure and a king puppet figure from the copies of Reproducible Page C.
3. Have the children color their puppets and then glue them onto the puppet cut-outs. See Figure A.

4. Help the children to bend the ends of each puppet cut-out around to the back and tape them together. See Figure B. NOTE: Be sure to tape them together so that it will fit around the bottom of the child's finger as a puppet.
5. Give each child a piece of brown construction paper. Have them rip the paper into small pieces.
6. Give each child a piece of poster board. Have the children glue the pieces of brown construction paper onto the poster board making a wall.
7. Have the children write their names on their walls.
8. Help the children to fold the sides of the poster board so that it will stand freely. See Figure C.

Conclusion

Have the children use their puppets and their walls to put on puppet shows for each other.

Teacher Tips

- Put the children's puppets back into their envelopes and tape the envelopes to their "walls" for them to take home.

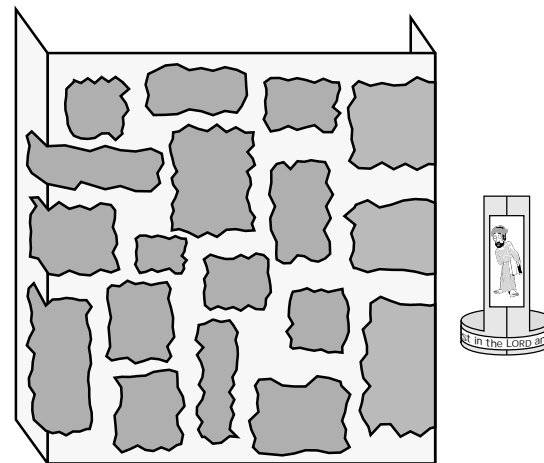

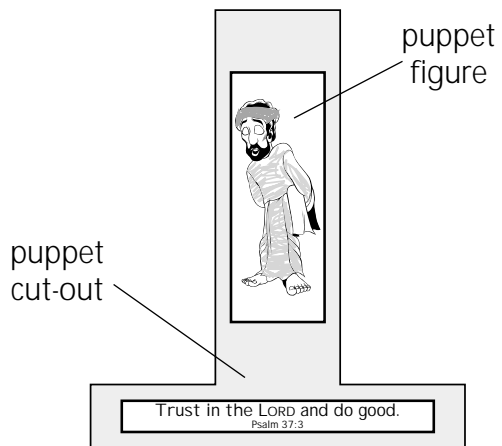

Figure A

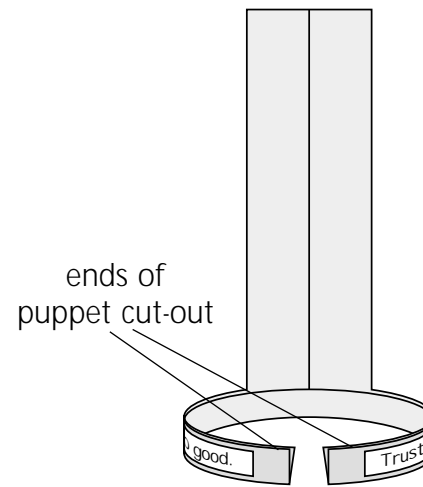

Figure B

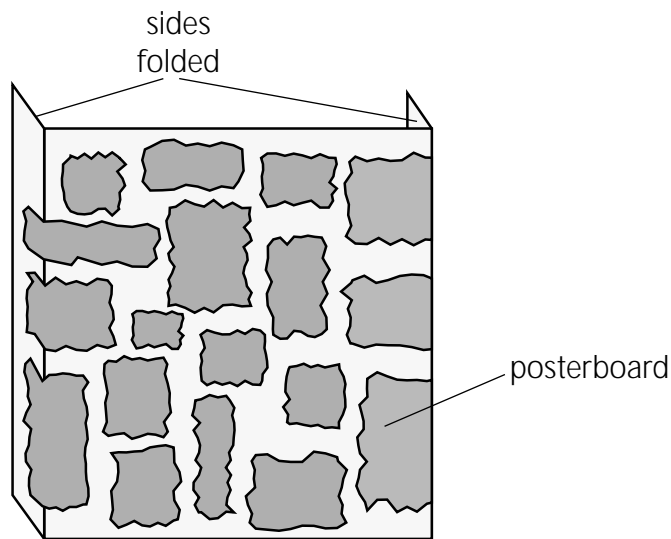
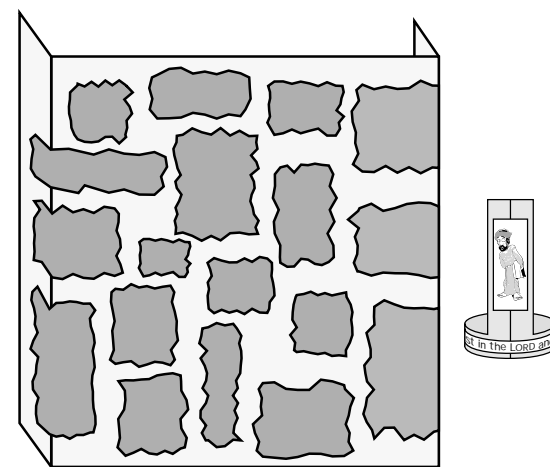

Figure C



Finished Craft



Nehemiah's Heart

Sorry!

The children will be reminded of Nehemiah's heart before God when they spell out the word sorry.

Scripture Memory Verse

Trust in the Lord and do good.
Psalm 37:3

Materials

For each child:

- a magazine or pages from magazines
- glue stick
- scissors

For the teacher:

- 5 pieces of poster board
- wide-tipped marker
- silver, orange, yellow and red crayons

Preparation

Spell out the word sorry by writing one large letter on each piece of poster board.

Instructions

1. Have the children sit in a circle. Spread the poster board letters on the floor in the correct order. *Does anyone know what word these letters spell? Yes, it is the word "sorry." That is what Nehemiah said to God when he learned that he and his people had hurt God. He prayed and told God he was sorry. If we hurt God or someone else how would it make them feel if we told them we are sorry? Yes, it makes them happy again.*
2. Divide the children into groups of two or four.

3. Show the children the first poster board with the letter S. Explain that the color silver starts with S. Ask the children to show you what the color silver looks like using the silver crayon as an example.
4. Give each group a magazine and have them cut or rip out pictures with the color silver in them.
5. Have the children glue the pictures onto the S poster board around the letter.
6. Have the children repeat this with each letter cutting out pictures of orange things for the O, red things for the R's and yellow things for the Y.

Scripture Memory Activity

Keep the children in their groups. Have them work in the group to practice the memory verse. Have them choose one person from the group to recite the verse.

Conclusion

Encourage the children to be quick to say that they are sorry when they are playing with others and at home, even if something was an accident. Ask them how it would make God and the person feel if they apologized.

Pray with the children about being quick to say they are sorry. Pray that they can bring their friends with them to Bible Class.

Teacher Tips

- Praise the children that are working together.

SORRY



Trust in the LORD
and do good.

Psalm 37:3



Core/Craft

1 copy for every 6 children

READ-OBEDIENCE

Page

A

Trust in the LORD and do good. Psalm 37:3	Trust in the LORD and do good. Psalm 37:3
Trust in the LORD and do good. Psalm 37:3	Trust in the LORD and do good. Psalm 37:3
Trust in the LORD and do good. Psalm 37:3	Trust in the LORD and do good. Psalm 37:3

text boxes

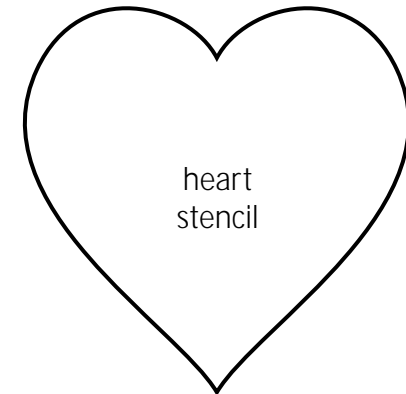

Supplement/Preclass

1 copy for every 5 children

RE-DEEMED

Page

B

Trust in the LORD and do good.

Psalm 37:3

Trust in the LORD and do good.

Psalm 37:3

Trust in the LORD and do good.

Psalm 37:3

Trust in the LORD and do good.

Psalm 37:3

Trust in the LORD and do good.

Psalm 37:3

Trust in the LORD and do good.

Psalm 37:3

Trust in the LORD and do good.

Psalm 37:3

Trust in the LORD and do good.

Psalm 37:3

Trust in the LORD and do good.

Psalm 37:3

Trust in the LORD and do good.

Psalm 37:3

text boxes



Supplement/Craft

1 copy for every 6 children

Read-Observe-Pray

Page

C

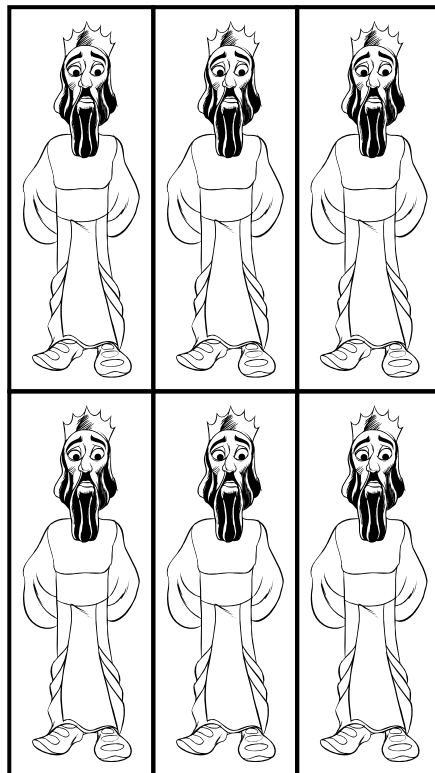

king puppet figures

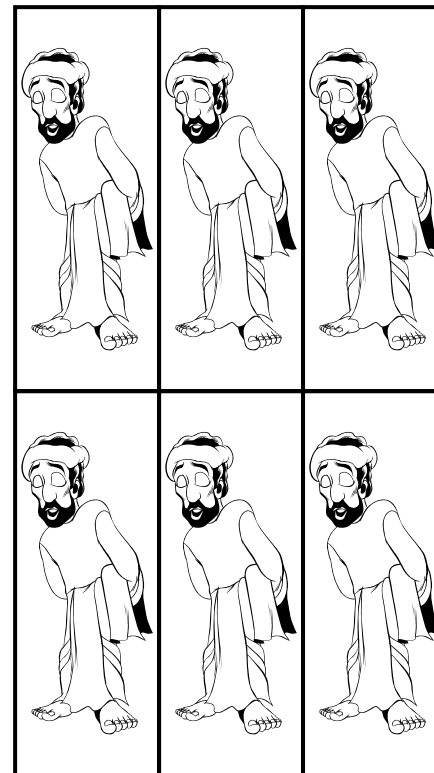

Nehemiah puppet figures

