

Ask Jesus for Help

Lesson Objectives

- The children will say "Jesus," when asked, "Who made the sick man well?"
- The children will role play emotions and learn that Jesus cares about their feelings.
- The children will pray to Jesus to help their sick friends.

Bible Story Text

Mark 2:1-12

Bible Truth

Jesus cares for me.
(1 Peter 5:7)

Lesson Plan

Greeting and Registration

Preclass Activity: Preclass Centers

Welcome and Singing

Centers:

Bible Story: Ask Jesus

Life Application: Feelings

Craft: Jesus Heals

NOTE: Be sure to allow sufficient time for a snack.



Ask Jesus for Help

Preclass Centers

As the children arrive, guide them to a preclass center. Have no more than six children at each center.

Materials

Use the materials previously selected for this unit's preclass centers.

Preparation

1. Be sure to check the condition of the materials selected for this unit's preclass centers prior to set up. Replace any broken toys, or puzzles with missing pieces as necessary.
2. Set up the centers before the children come into the classroom.
3. Assign a teacher to each center and have the teachers stay in those centers until the singing begins.

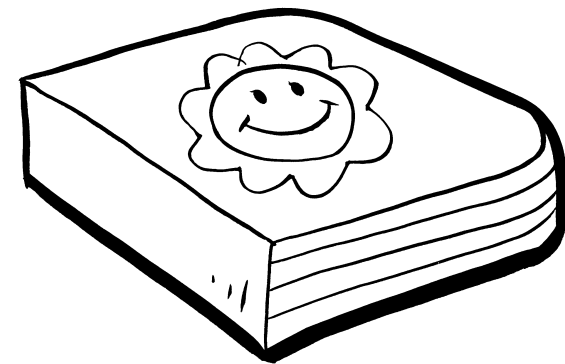
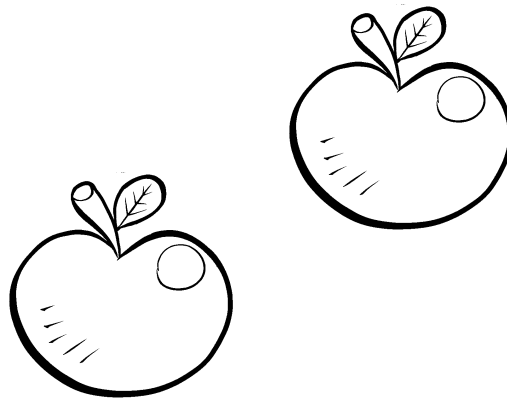

Instructions

Guide the play in each center reinforcing the unit theme.

Teacher Tips

- **IMPORTANT:** Do not allow any small toys in the classroom. First check all toys for size. You can obtain a "safety cylinder" from a pediatrician. Any object that can fit into the cylinder is too small and could cause a child to choke.
- Be involved in the group play and offer guidance as needed.
- Wear comfortable clothes suitable for sitting on the floor.
- Smile! Be childlike in heart and alert in mind.

Ask Jesus for Help

Ask Jesus

The children will learn that Jesus made a sick man walk. They will understand that Jesus has great power and he cares about them and their feelings.

Bible Story Text

Mark 2:1-12

Materials

For the teacher:

- Bible
- large shoebox
- magazine pictures of people
- glue
- scissors
- 2 craft sticks
- 1 piece of fabric or construction paper, 3½" x 2", as a mat
- 1 piece of yarn, 24"
- markers or crayons
- tape

Reproducible Pages:

- Page A, 1 copy for the teacher

Preparation

1. Color and cut out the figures from the copy of Reproducible Page A.
2. Place the shoebox on its side. This will be the inside of a house.
3. Glue magazine pictures of people to cover the inside back and side walls of the box, so the house looks full of people.
4. Prepare a mat for the paralytic as follows:
 - A. Punch two holes in the fabric as shown in Figure A.
 - B. Glue the two craft sticks onto the fabric, being careful not to cover the holes. See Figure B.
 - C. Glue the figure of the "lying paralytic" onto the mat.
 - D. Cut a 24" piece of yarn.
 - E. Thread the yarn through the two holes in the mat and tie the ends together.
5. Cut a flap in the roof of the shoebox large enough for the mat to fit through. See Figure C.

Help

Open the Bible. *Have you ever been in a crowded room so full of people that you were all sitting very close together? Tape Jesus inside the house. The Bible says that one day Jesus went to a house for a Bible study. So many people gathered in and around the house to hear Jesus that no one else could get in the door! That is a lot of people, isn't it? A lot of people wanted to know about God. Do your daddies and mommies have Bible studies with people? That is just like Jesus!*

There was a man who was sick, his legs didn't work. He wanted to see Jesus. He wanted Jesus to make him well, but he could not walk to get there. Show the children the man on the mat. Let them touch him. He is lying on the mat because he cannot walk. That is sad, isn't it? His friends felt sad for him. They wanted him to be able to walk. They knew Jesus could help him. Show the children the friends. They had an idea. They would carry him on his mat to see Jesus.

When they got to the house they tried to get in the door, but there were too many people! They could not get in! But they didn't give up. Guess what they did? Place the friends and the paralytic on the mat on top of the house. They had a great idea! They made a hole in the roof and lowered their friend down on his mat so Jesus could make him well! Lower the mat by the strings through the flap until the man is on the "floor" next to Jesus.

What do you think Jesus did when he saw the man? He told the man to get up and walk! So the man stood up and walked! Jesus made his legs get well! Remove the mat and show the children the paralytic standing. How do you think the man felt? Make the man dance and jump around and say "thank you" to Jesus. How do you think his friends felt? Have the friends hug him, dance around and say "thank you" to Jesus.

Sing "Jesus, Jesus, I Am Sick" from the Unit 20 Song Sheet. Let each child have a turn lowering the sick man down to Jesus, then make him stand up, dance and jump and say "thank you" to Jesus. NOTE: Save the figures, mat and the house for the Unit 20 Lesson 4, Bible Story.

Ask Jesus for Help

Conclusion

Have the children sit down and answer the following questions to review the story:

- Who was having a Bible study? (Jesus)
- What was wrong with the sick man? (his legs didn't work)

- How did the sick man get to Jesus? (his friends carried him on his mat and lowered him through the roof)
- Should we help our sick friends? (yes)
- Does Jesus care for you? (Yes!)

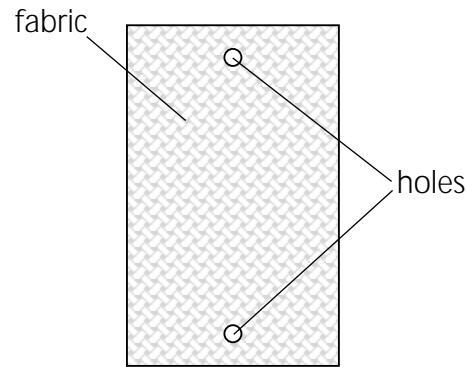

Figure A

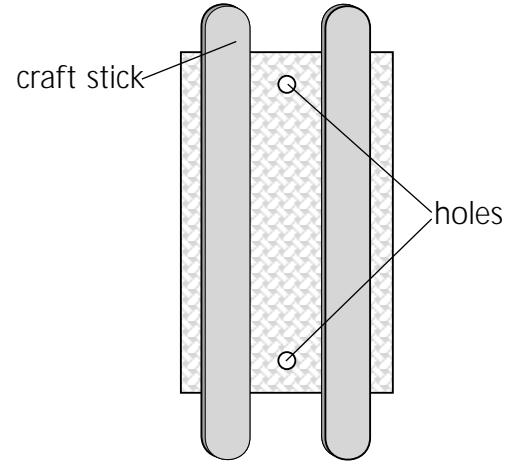

Figure B

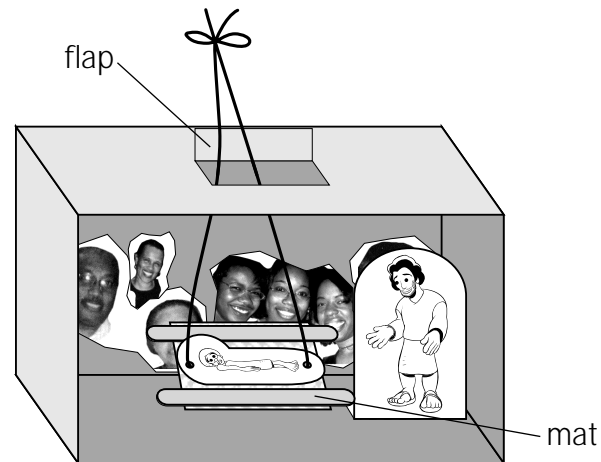

Figure C

Ask Jesus for Help

Feelings

The children will learn that Jesus cares about their feelings.

Bible Truth

Jesus cares for me.
(1 Peter 5:7)

Materials

For the teacher:

- Bible
- magazines with pictures of people
- scissors
- glue stick
- construction paper
- hand mirror
- clear contact paper or laminate (optional)

Preparation

1. Cut out pictures of people from magazines with different expressions or emotions: happy, sad, afraid, angry, frustrated, concerned, etc. Cut out one picture for each child. NOTE: Choose large pictures.
2. Glue each picture onto a piece of construction paper. Have at least one picture for each child in your small group.

Instructions

We are going to talk and sing about our feelings. Can anyone tell me what feelings are? Our feelings are what our hearts feel; how our eyes look; and the expression on our face. What does it mean if you are feeling happy? How does your face look? What does it mean if you are feeling sad? How does your face look?

Sing the first three verses of "If You're Happy, and You Know It" from the Unit 20 Song Sheet. Be very enthusiastic as you sing. *How does your face look when you are happy?* Show each child their happy face in the mirror.

Sing the last five verses of "If You're Happy, and You Know It." After you sing each verse, have the children make that expression and show them their expression in the mirror.

Show the children the magazine pictures of people with different expressions. Talk about how each person is feeling. Give each child a picture after you have talked about it.

Sing the song again. As you sing about each emotion have the children with the picture reflecting that emotion hold up the picture. Sing until all the children are holding up their pictures.

NOTE: Save the pictures for the Unit 20 Lesson 4, Life Application.

Bible Truth Activity

Open the Bible. *The Bible says, "Jesus cares for me." Let's say that together: "Jesus cares for me." (Child's name) _____, does Jesus care for you? Yes, He does! Repeat this for each child.*

Hold up each magazine picture as you speak. *Jesus cares about you when you are happy. He cares about you when you are sad. He cares about you when you are scared. He cares about you when you feel mad. Jesus cares about you all the time.*

Conclusion

Let's talk to God. Dear God, thank you for loving us and caring for us all the time. We love you! In Jesus' name we pray. Amen.

Who are you going to tell about Bible class today? What are you going to tell them?

Teacher Tips

- Be sure pictures are appropriate for very young children: fairly simple, not too sad, scary or intense.
- You may have a very sensitive child who gets sad from a picture of someone who is crying. If so, put the picture away, and go on to a happy picture.
- Keep your voice light, even when showing a sad picture or making a sad face. You may frighten the children if you act out intense emotions.
- Laminate the pictures to make them last longer.

Jesus cares for me.



Ask Jesus for Help

Jesus Heals

This craft will help the children remember the lesson of Jesus healing the paralytic.

Materials

For each child:

- 1 piece of poster board, 9" x 12"
- construction paper 2" x 5"
- 1 piece of yarn, 24"
- 1 craft stick
- glue stick
- crayons

For the teacher:

- marker
- scissors
- white glue
- ruler
- hole punch
- crayons

Reproducible Pages:

- Page A, 1 copy for each child

Preparation

1. Cut out the figures from the copies of Reproducible Page A.
NOTE: You will not need the figure of the paralytic standing up.
2. Make a "house" for each child as follows, see Figure A:
 - A. Fold down the top 1½" of each piece of poster board, creating a roof.
 - B. Punch two holes in the center of the roof, 2½" apart.
3. Make a mat for each child as follows, see Figure B.
 - A. Cut a 2" x 5" piece of construction paper for each child.
 - B. Punch two holes along the top of the construction paper.
 - C. Glue the craft stick onto one side of the construction paper being careful not to cover the holes.
 - D. Cut a 24" piece of yarn for each child and thread it through the holes in the mat.
4. Make a model of the craft following the instructions.

Instructions

1. Show the children the model of the craft. Demonstrate lowering the man down to Jesus. Allow each child to have a turn. *Today we are learning about the man that could not walk. His friends lowered him through a hole in the roof to ask Jesus to heal him.*
2. Give each child a picture of Jesus, the four friends and the paralytic to color.
3. Give each child a house and have them draw some people on it.
4. Help each child glue Jesus to the house.
5. Help each child to glue the friends to the top back of the house so they appear to be on the roof. See Figure C.
6. Help each child to glue the paralytic onto the mat on the opposite side of the craft stick. See Figure D.
7. Help the children thread the ends of the yarn through the holes in the roof and tie the ends together.

Conclusion

Sing "Jesus, Jesus, I Am Sick" from the Unit 20 Song Sheet. Use the craft as a prop.

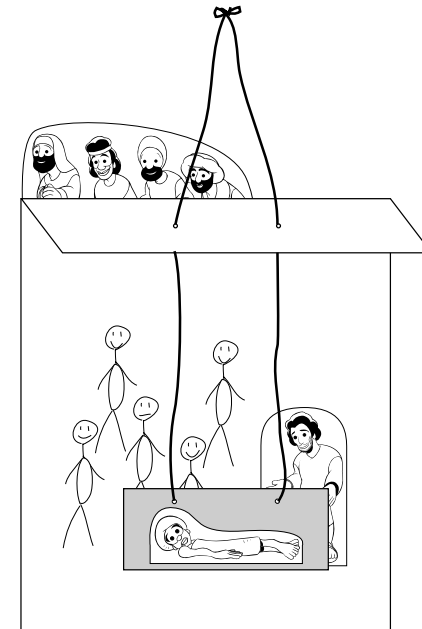

craft

Ask Jesus for Help

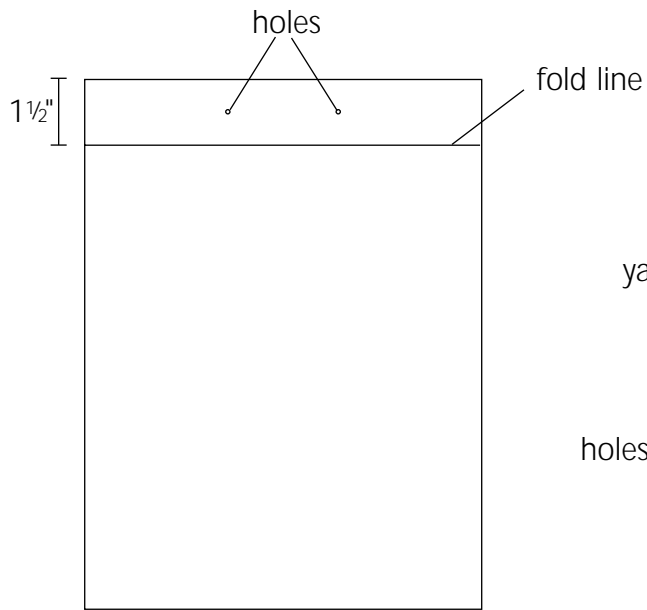

Figure A

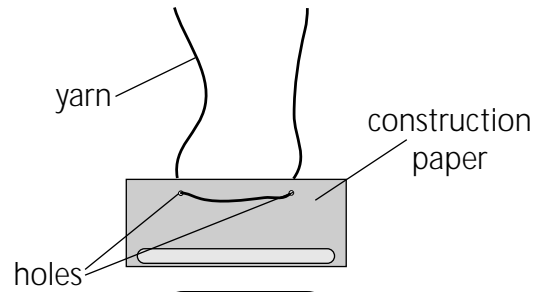

Figure B

four friends from
Reproducible Page A

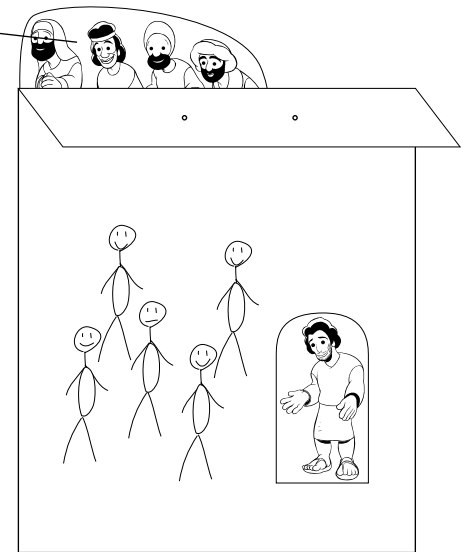

Figure C

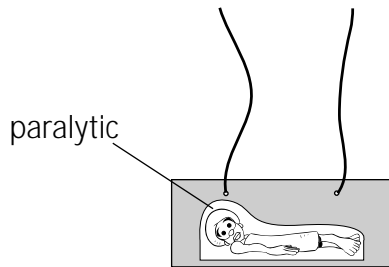
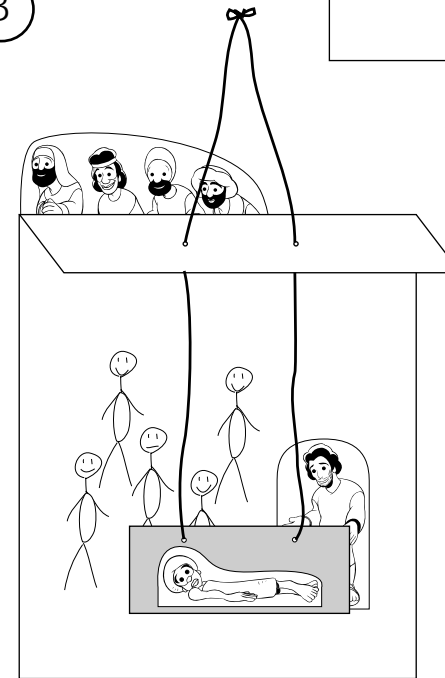

Figure D



Finished Craft





Ask Jesus for Help

Jesus Cares

Lesson 3

Lesson Objectives

- The children will say "Jesus," when asked, "Who made the sick man well?"
- The children will role play emotions and learn that Jesus cares about their feelings.
- The children will pray to Jesus to help their sick friends.

Bible Story Text

Mark 2:1-12

Bible Truth

Jesus cares for me.
(1 Peter 5:7)

Preclass Centers

As the children arrive, guide them to a pre-class center. Have no more than six children at each center.

Materials

Use the materials previously selected for this unit's preclass centers.

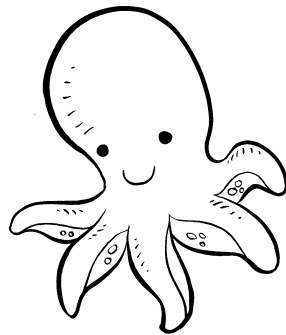

Preparation

1. Be sure to check the condition of the materials selected for this unit's preclass centers prior to set up. Replace any broken toys, or puzzles with missing pieces as necessary.
2. Set up the centers before the children come into the classroom.
3. Assign a teacher to each center and have the teachers stay in those centers until the singing begins.

Instructions

Guide the play in each center reinforcing the unit theme.

Lesson Plan

Greeting and Registration

Preclass Activity: Preclass Centers

Welcome and Singing

Centers:

Life Application: Caring for Sick Friends

Bible Story: Ask Jesus

Craft: Healed

NOTE: Be sure to allow sufficient time for a snack.

Teacher Tips

- **IMPORTANT:** Do not allow any small toys in the classroom. First check all toys for size. You can obtain a "safety cylinder" from a pediatrician. Any object that can fit into the cylinder is too small and could cause a child to choke.
- Be involved in the group play and offer guidance as needed.
- Wear comfortable clothes suitable for sitting on the floor.
- Smile! Be childlike in heart and alert in mind.

Life

Application

Caring for Sick Friends

The children will role play caring for sick friends.

Bible Truth

Jesus cares for me.
(1 Peter 5:7)

Materials

For each child:

- 1 stuffed animal
- 1 small bandage for the stuffed animal
- 1 small blanket, dishtowel or washcloth

For the teacher:

- Bible
- pillow case

Preparation

1. Learn "Jesus, Jesus, I Am Sick" and "I Thank You for My Legs" from the Unit 20 Song Sheet.
2. Familiarize yourself with the activity.

Instructions

Open the Bible. *The Bible says that there was a man who was sick. He could not walk. His friends tried to bring the man to Jesus so Jesus could make him well. But there were so many people that they could not get into the house to see Jesus! The Bible says that they made a hole in the roof, and they lowered their friend on his mat down to Jesus. And do you think Jesus made their friend well? Yes, He did! His friend got up off that mat, and walked and jumped around. He was so happy he could walk!*

Give each child a stuffed animal. *Today we are going to pretend that these stuffed animals are our sick friends. They all have hurt their legs and they cannot walk.* Ask the children what they can do to help their sick animals (hug them, give medicine, etc.).

Give each child a bandage. *Would you like to bandage his leg?*

Give each child a small blanket. *Would you like to cover your sick friend with a blanket?*

Let's pretend that Jesus is here preaching, but we can't get to him because the room is too crowded. Let's lower our friends down to Jesus, so he can make them well.

Choose a child to be Jesus. Place an animal on the pillow case and lower it down next to Jesus. Have "Jesus" touch the animal and pretend to heal it.

Have the children take turns lowering their animal down to Jesus. Sing "Jesus, Jesus, I Am Sick" from the Unit 20 Song Sheet. Act out the song using the animals as props.

If time allows, let each child demonstrate one thing we can do with our legs, e.g.: jump, dance, skate, run, hop, swim, etc. As each child takes a turn, sing an appropriate verse of the song "I Thank You for My Legs" from the Unit 20 Song Sheet.

Bible Truth Activity

Open the Bible. *The Bible says, "Jesus cares for me." Let's say that together: "Jesus cares for me." (Child's name) _____, does Jesus care for you? Yes, He does! Repeat this for each child. Jesus cares for you when you are sick.*

Conclusion

Let's talk to God. Dear God, thank you for loving us and caring for us when we are well and when we are sick. Help us to love and take care of other people when they are sick. Thank you for giving us strong legs! In Jesus' name we pray. Amen.

Who are you going to tell about Bible class today? What are you going to tell them?

Teacher Tips

- Be very sensitive if you have a child or a close family member of a child who is in a wheelchair. Be sure that you acknowledge that Jesus loves them, and he has given them family and friends to help care for their needs.



Ask Jesus

The children will learn that Jesus made a sick man walk. They will understand that Jesus has great power and he cares about them and their feelings.

Bible Story Text

Mark 2:1-12

Materials

For the teacher:

- Bible
- large shoebox
- magazine pictures of people
- glue
- scissors
- 2 craft sticks
- 1 piece of fabric or construction paper, 3½" x 2", as a mat
- 1 piece of yarn, 24"
- markers or crayons
- tape

Reproducible Pages:

- Page A, 1 copy for the teacher

Preparation

1. Color and cut out the figures from the copy of Reproducible Page A.
2. Place the shoebox on its side. This will be the inside of a house.
3. Glue magazine pictures of people to cover the inside back and side walls of the box, so the house looks full of people.
4. Prepare a mat for the paralytic as follows:
 - A. Punch two holes in the fabric as shown in Figure A.
 - B. Glue the two craft sticks onto the fabric, being careful not to cover the holes. See Figure B.
 - C. Glue the figure of the "lying paralytic" onto the mat.
 - D. Cut a 24" piece of yarn.
 - E. Thread the yarn through the two holes in the mat and tie the ends together.
5. Cut a flap in the roof of the shoebox large enough for the mat to fit through. See Figure C.

Help

Open the Bible. *Have you ever been in a crowded room so full of people that you were all sitting very close together? Tape Jesus inside the house. The Bible says that one day Jesus went to a house for a Bible study. So many people gathered in and around the house to hear Jesus that no one else could get in the door! That is a lot of people, isn't it? A lot of people wanted to know about God. Do your daddies and mommies have Bible studies with people? That is just like Jesus!*

There was a man who was sick, his legs didn't work. He wanted to see Jesus. He wanted Jesus to make him well, but he could not walk to get there. Show the children the man on the mat. Let them touch him. He is lying on the mat because he cannot walk. That is sad, isn't it? His friends felt sad for him. They wanted him to be able to walk. They knew Jesus could help him. Show the children the friends. They had an idea. They would carry him on his mat to see Jesus.

When they got to the house they tried to get in the door, but there were too many people! They could not get in! But they didn't give up. Guess what they did? Place the friends and the paralytic on the mat on top of the house. They had a great idea! They made a hole in the roof and lowered their friend down on his mat so Jesus could make him well! Lower the mat by the strings through the flap until the man is on the "floor" next to Jesus.

What do you think Jesus did when he saw the man? He told the man to get up and walk! So the man stood up and walked! Jesus made his legs get well! Remove the mat and show the children the paralytic standing. How do you think the man felt? Make the man dance and jump around and say "thank you" to Jesus. How do you think his friends felt? Have the friends hug him, dance around and say "thank you" to Jesus.

Sing "Jesus, Jesus, I Am Sick" from the Unit 20 Song Sheet. Let each child have a turn lowering the sick man down to Jesus, then make him stand up, dance and jump and say "thank you" to Jesus. NOTE: Save the figures, mat and the house for the Unit 20 Lesson 4, Bible Story.

Ask Jesus for Help

Conclusion

Have the children sit down and answer the following questions to review the story:

- Who was having a Bible study? (Jesus)
- What was wrong with the sick man? (his legs didn't work)

- How did the sick man get to Jesus? (his friends carried him on his mat and lowered him through the roof)
- Should we help our sick friends? (yes)
- Does Jesus care for you? (Yes!)

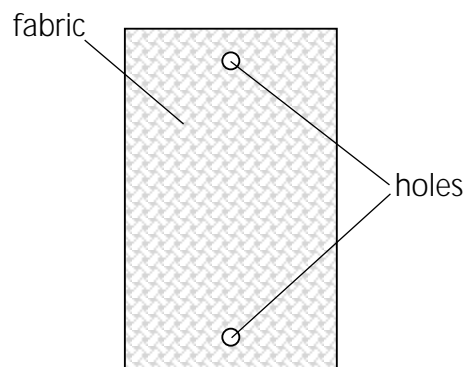

Figure A

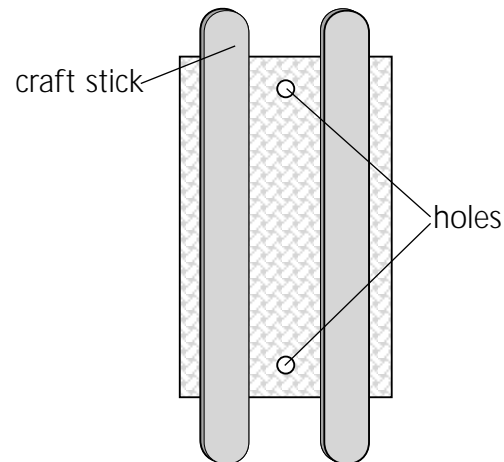

Figure B

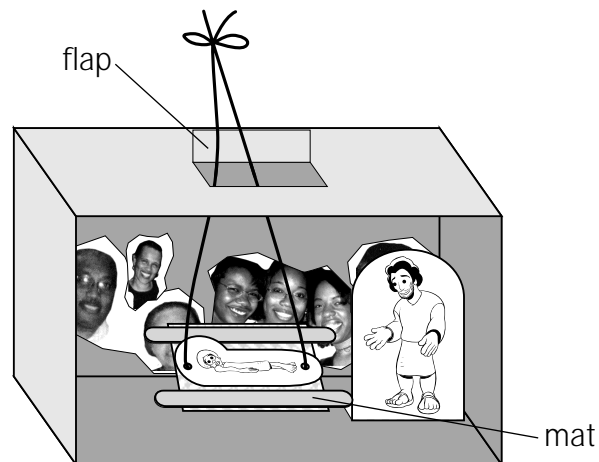

Figure C



C
r
a
f
t

Healed

This craft will remind the children of the paralytic whom Jesus healed.

Materials

For each child:

- 1 piece of poster board, 3" x 5½"
- 1 piece of construction paper, 3½" x 3½"
- 1 piece of fabric, 5" x 5"
- 1 beige or brown pipe cleaner
- glue stick
- crayons

For the teacher:

- scissors
- tacky glue
- hole punch
- tape
- black marker

Reproducible Pages:

- Page B, 1 copy for each child

Preparation

1. Cut out the face from the copies of Reproducible Page B.
2. Cut out one coat stencil from one copy of Reproducible Page B.
3. Trace and cut out one coat for each child from fabric.
4. Prepare a "puppet body" for each child as follows, see Figure A:
 - A. Cut a 3" x 5½" piece of poster board for each child.
 - B. On one of the 3" ends of the poster board cut two ½" leg holes side by side. NOTE: The holes should be large enough for a child to put their fingers through. Their fingers will be the man's legs.
 - C. Punch two holes on either side of the poster board towards the top. These will be holes for the arms.
5. Cut a 3" circle from construction paper for each child.
6. Make a model of the craft following the instructions.

Instructions

1. Place the model of the craft lying down on the table. *What is wrong with this man? Does anyone remember what is wrong with him? He cannot walk. His legs do not work. What did his friends do? They brought him to Jesus. What did Jesus do? He made the man well! Stick your fingers in the holes of the puppet for legs. Make the man get up, jump and dance around. What do you think the man said to Jesus? Thank you, Jesus!*
2. Give each child a copy of the face to color.
3. Give each child a construction paper circle and have them glue the face onto the circle.
4. Have each child glue the circle and face onto the piece of poster board above the arm holes.
5. Help each child to thread a pipe cleaner from the back of the cardboard through the two holes as arms. Curl each pipe cleaner end as hands. See Figure B.
6. Give each child a coat to glue onto the poster board body.
7. Write each child's name on their craft.

Conclusion

Have each child lay his man down on the table. Sing the songs "Jesus, Jesus, I Am Sick" and "I Thank You for My Legs" from the Unit 20 Song Sheet. Use the puppet to act out the songs, as you sing.

Teacher Tips

- Trim the coat if necessary so it does not cover the "leg" holes.

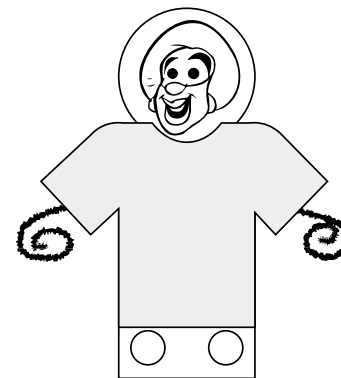

Craft

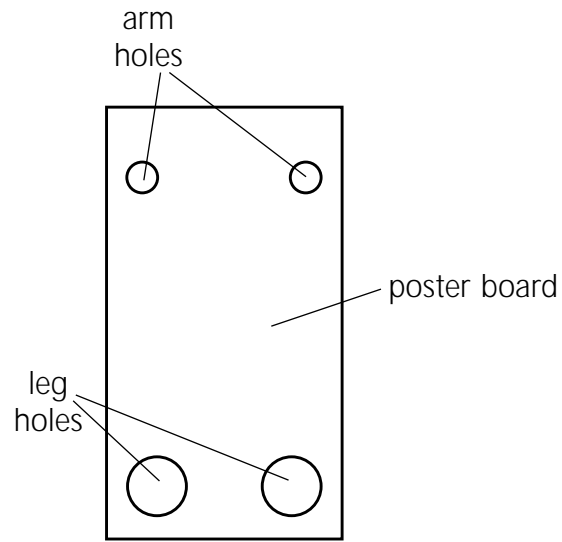

Figure A

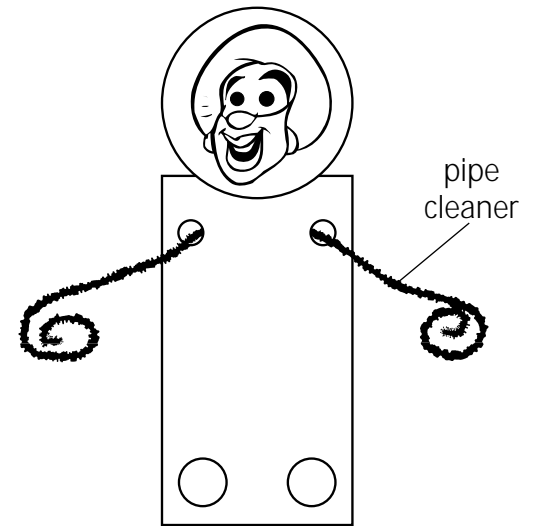
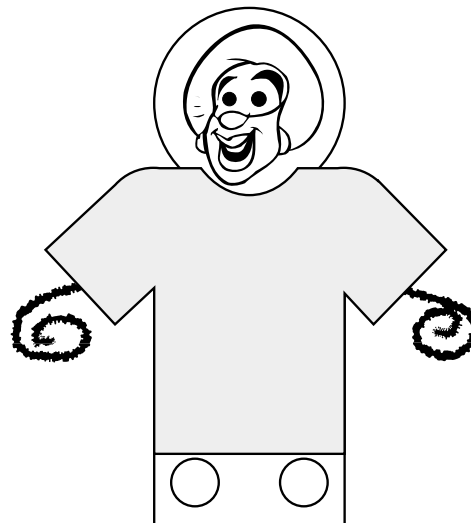

Figure B



Finished Craft





A
P
P
R
E
C
I
A
T
E



paralytic standing



Jesus

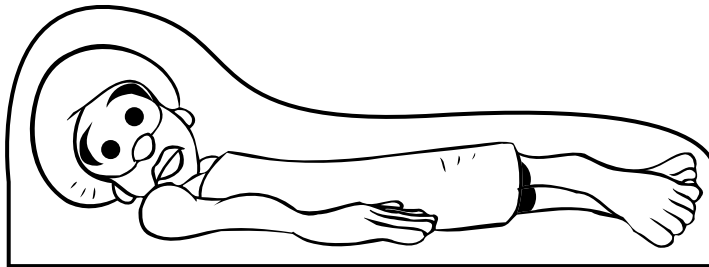

paralytic lying

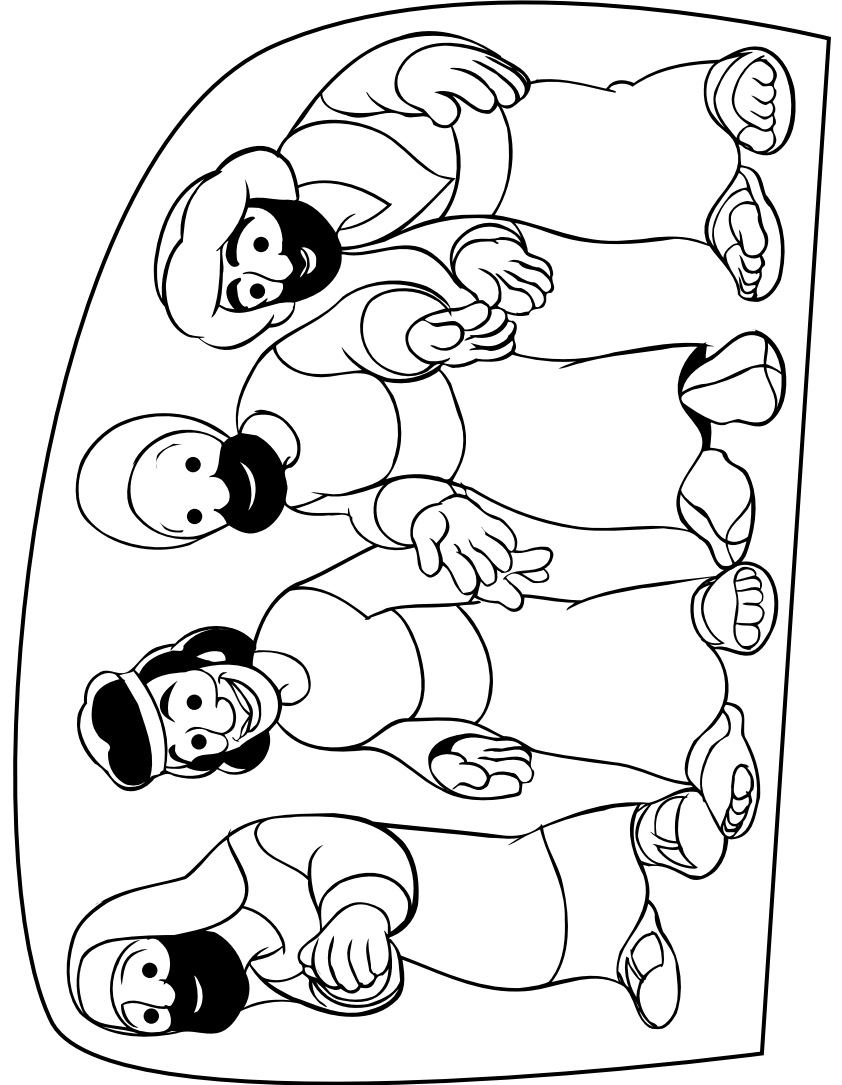

four friends





R
e
p
r
o
d
u
c
e
d
b
y
e

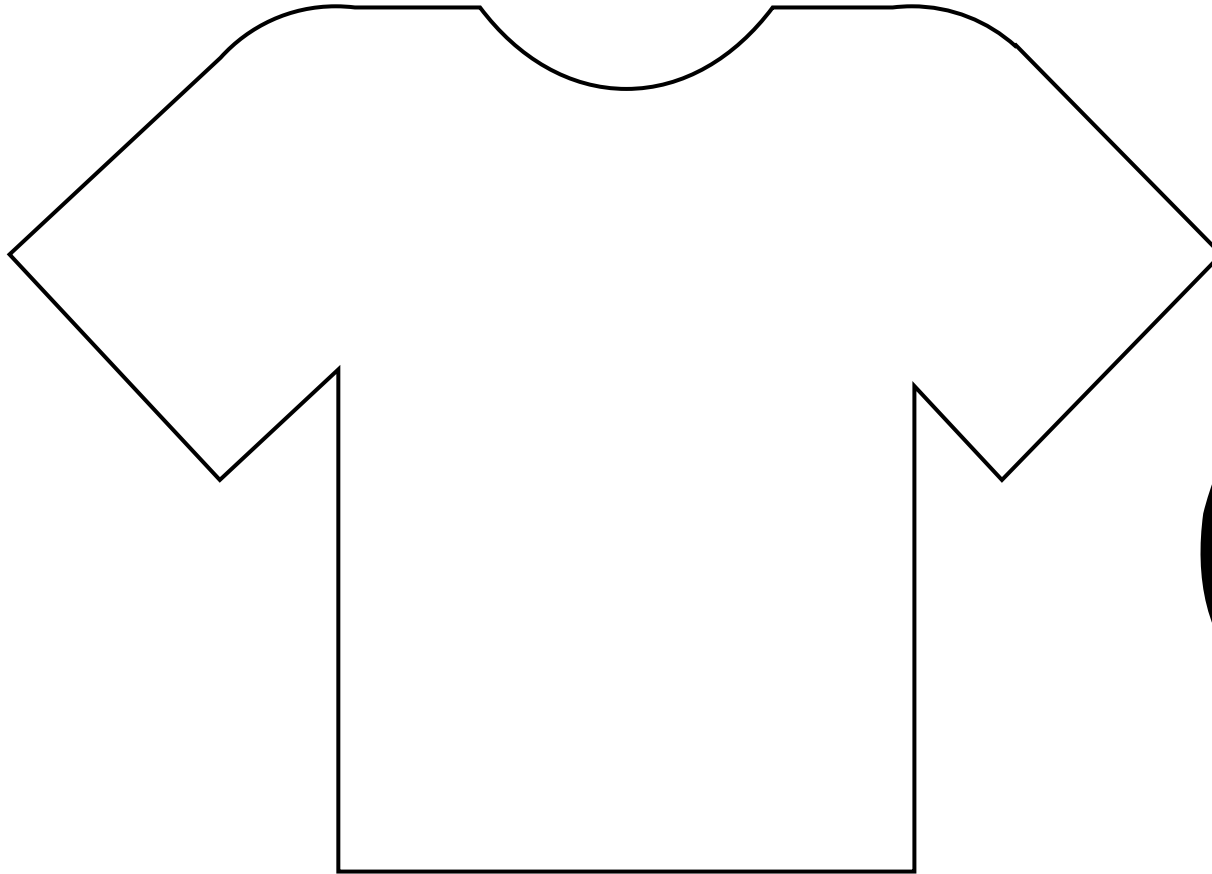

coat stencil



face

