

Do Not Be Afraid

Lesson Objectives

- The children will role play Jesus calming the storm.
- The children will sing about not being afraid.
- The children will say, "Jesus cares for me."

Bible Story Text

Mark 4:35-41

Bible Truth

Jesus cares for me.
(1 Peter 5:7)

Lesson Plan

Greeting and Registration

Preclass Activity: Preclass Centers

Welcome and Singing

Centers:

Bible Story: No Fear

Life Application: It's Okay Sarah!

Craft: Boat in the Storm

NOTE: Be sure to allow sufficient time for a snack.

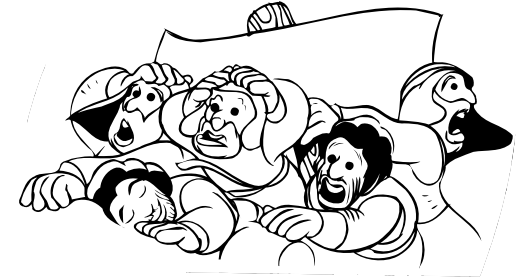

Do Not Be Afraid

Preclass Centers

In the preclass centers children will use language, motor, and cognitive skills, learn to interact with peers and cooperate in small groups.

Select four centers to use this unit. Assign a teacher to set up and supervise each center with no more than six children.

Materials

IMPORTANT: Do not allow any small toys in the classroom. First check all toys for size. You can obtain a "safety cylinder" from a pediatrician. Any object that can fit into the cylinder is too small and could cause a child to choke.

- Housekeeping Center—2 washable dolls (of diverse ethnicity, e.g., black and white), play food, dishes and 2 small blankets
- Story Center—simple books with limited text (cardboard are the most sturdy and durable) and large pillows
- Block Center—set of large blocks, people, animal figures (plastic or wooden) and toy cars
- Puzzle Center—1 puzzle for each child (for twos each puzzle piece itself should be a complete familiar object, for threes most can complete a 20-piece puzzle). **NOTE:** A puzzle should have all the pieces. If a puzzle piece is lost, the entire puzzle should be thrown out.

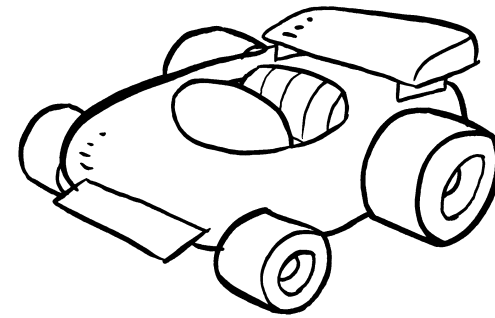
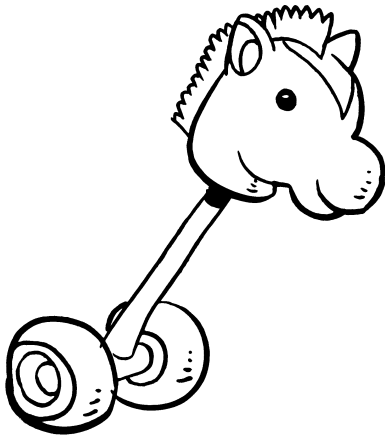

Instructions

Guide the play in each center reinforcing the unit theme. Refer to the following example for help in directing play and asking relevant questions.

Set up the Housekeeping center as a boat. Have different children take turns rowing the boat and putting up pretend sails. Ask the children what they see in the water. Ask them what the weather is like. Ask them if they are afraid and reassure them that God is taking care of them.

Teacher Tips

- You may want to try other centers such as transportation, large motor or manipulative.
- Wear comfortable clothes suitable for sitting on the floor.

Do Not Be Afraid

No Fear

The children will hear the story of Jesus calming the storm. They will understand that Jesus takes care of them just as he took care of his disciples.

Bible Story Text

Mark 4:35-41

Materials

For the teacher:

- Bible
- fan (for wind)
- water spray bottle (for rain)
- 1 large piece of poster board (to make thunder)
- yellow crepe paper strips (for lightning)
- large blue sheet or tablecloth (for the sea)
- large box or laundry basket (for the boat) have enough for all the children in the small group to be seated inside one
- sheet
- scarf

Preparation

1. Before the children arrive set up the Bible Story area as follows:
 - A. Plug in the fan and place it where the children won't be able to reach it.
 - B. Spread out the blue sheet on the floor as the sea. Crumple the fabric to represent waves.
 - C. Place the boxes on the sheet as boats.
 - D. Drape the sheet over your shoulder and tie it at your waist with the scarf.
2. Fill the spray bottle with water.

Be Quiet!

As the children come into the center invite them to step into one of the boats. *Hello! Come in and sit down in our boat. Let's pretend this is the boat Jesus was in with his disciples. You pretend to be the disciples, and I will pretend to be Jesus.*

Open the Bible. *One day Jesus and his disciples were out in the boat. Jesus was very tired and he lay down and went to sleep. While he was sleeping, a storm started.*

Have you ever felt the wind blow really hard in a storm? Turn on the fan, so it blows on the children. Do you feel the wind blowing?

Have you ever been outside and gotten all wet from the rain? Hold out your hand, and feel the rain. Spray their hands with water from the spray bottle. The Bible says it started to rain. Then it started thundering. Give a child the poster board to shake to make sounds of thunder. And then the lightning started. Give two children yellow streamers. Have them stand up and shake the streamers to look like lightning.

How do you think the disciples felt? Do you think they felt scared? Yes, they were very scared. Have you ever been scared of a storm when the rain and thunder are very loud? Do you think Jesus was scared? Do you know what he was doing? Lie down on the floor and pretend to be asleep. He was sound asleep! He was not afraid at all.

The disciples woke him up saying, "Jesus, wake up! We are afraid of the storm!" Jesus woke up and looked around. Do you think he was afraid? Stand up, and hold out your arms. He just stood up and said to the storm, "Quiet! Be still!" (Mark 4:39).

Do you know what happened when he said this? The wind stopped! Turn off the fan. The rain stopped! Put away the spray bottle. The thunder stopped. Put away the poster board. The lightning stopped, put away the streamers, and the waves settled down on the lake. Smooth out the sheet. And everyone was safe!

Do you think the disciples felt happy? Yes, they were very happy! Jesus has so much power! He can tell a storm to stop and it obeys him right away. The Bible says, "Jesus cares for me." Can you say that? Jesus cares for me! I don't ever have to be afraid! Jesus is so strong, he cares for me and he always protects me!
Sing "Must Be Jesus" from the Unit 20 Song Sheet.



Do Not Be Afraid

Conclusion

Have the children answer the following questions to review the story:

- Who was asleep in the boat? (Jesus)
- What happened to the boat on the water? (it was caught in a storm)
- How did the disciples feel? (afraid)
- What did Jesus do about the storm? (he made it stop)
- Does Jesus care for you? (Yes!)

Teacher Tips

- **IMPORTANT:** Do not allow the children to get close to the fan or to the fan cord.

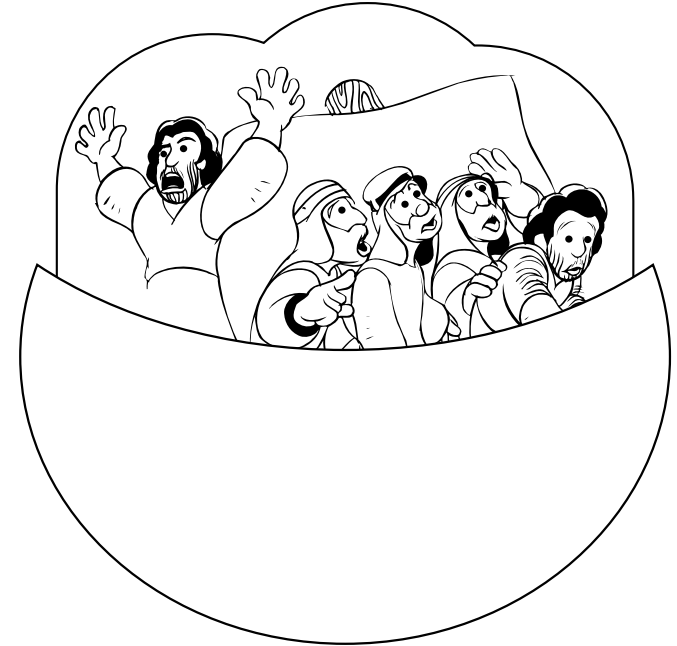
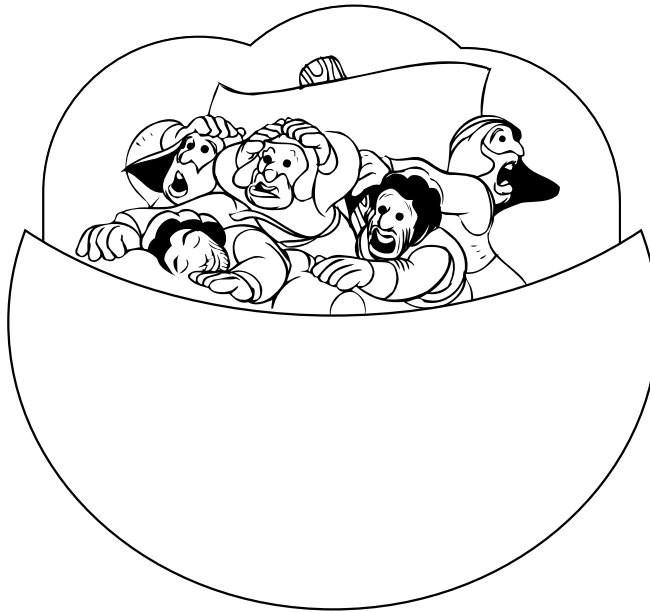

Do Not Be Afraid

It's Okay Sarah!

The children will learn that Jesus takes care of them so they should not be afraid.

Bible Truth

Jesus cares for me.
(1 Peter 5:7)

Materials

For the teacher:

- Bible
- felt board
- poster board
- watercolor markers or crayons
- glue stick
- scissors
- clear contact paper or laminate
- masking tape

Reproducible Pages:

- Page A, 1 copy for the teacher
- Page B, 1 copy for the teacher
- Page C, 1 copy for the teacher

Preparation

1. Cut out and color the felt board figures and windows from the copies of Reproducible Pages A, B, and C.
2. Laminate the figures to make them last longer.
3. Place a rolled piece of tape on the back of each figure.
4. Familiarize yourself with the songs and the story.

Instructions

Show the children each felt board figure. *This is a young boy. Do you remember his name? David! This is his sister. Do you remember her name? Her name is Lesli. This is the baby. She is growing and getting bigger! Now she can walk and talk. Do you remember her name? Her name is Sarah! These are the baby-sitters. Their names are Barry and Debbie. Do you have baby-sitters that come and take care of you sometimes?*

Place Sarah, David, Lesli, Barry and Debbie on the felt board. *Mommy and Daddy had just left the house for their anniversary. They would be back tomorrow but baby Sarah was scared and sad*

without her mommy. Lesli came over and gave Sarah a hug. Then they went into the kitchen to play while Debbie cooked dinner. Sarah was happy now. "I am so proud of you Sarah." Lesli said to her. "You are a big girl, and you are having fun with Barry and Debbie! You are not afraid! Mommy tells me that I never have to be afraid because Jesus always watches over me. He watches over you, too!"

Dinner was delicious, and it was fun playing games with Barry and Debbie after dinner. Soon it was time for bed. Everyone got ready for bed. Barry tucked in David after he said his prayers. Debbie tucked in the girls and helped them say their prayers. Of course, Sarah did not say much in her prayer except "God" and "Amen!"

Debbie turned off the light. It was dark in the room. Baby Sarah lay very still and quiet. But then suddenly she saw something. It was a shadow. Place the shadow window on the felt board. Sarah was scared. She started to cry. "It is okay," said Lesli. "you do not have to be afraid." Lesli turned on the light. "See! It was only a shadow. A shadow cannot hurt you. We should not be afraid. Mommy says that Jesus watches over me, so I know he watches over you, too. I will sing to you what Mommy sings to me when I am afraid." Sing "Jesus Loves Me" from the Unit 20 Song Sheet. When Lesli finished singing Sarah was sound asleep.

But in the middle of the night a storm started. Remove the shadow window and replace it with the storm window. The rain was loud, the thunder was even louder and the lightning was very bright. Baby Sarah woke up scared and she started to cry. David came to her bedside. "It is okay, Sarah," he said. "It is only the wind and the rain. I know it is very loud, but it will not hurt you. Daddy says that Jesus can make the rain and the wind stop. He will watch over you. I will sing to you what Daddy sings to me when I am afraid. Sing "Jesus Loves Me" again. When David finished singing the song, Sarah was sound asleep.

Show the children the pictures of the baby-sitters, the shadow and the storm. Then end the story with "Is It Scary?" from the Unit 20 Song Sheet.

NOTE: Save the felt board figures for the Unit 20 Lesson 2, Life Application.



Do Not Be Afraid

Bible Truth Activity

Today in our story, what did Baby Sarah learn? She learned that Jesus takes care of her so she does not need to be afraid. Open the Bible. The Bible says, "Jesus cares for me." Let's all say that together: "Jesus cares for me." Ask each child, do you know why you do not have to be afraid? Help each child answer: "Because Jesus cares for me."

Conclusion

Let's talk to God. Dear God, thank you for taking care of us every day. Thank you that Jesus cares for us, so we do not have to be afraid.

Who are you going to tell about Bible class today? What are you going to tell them?

Teacher Tips

- Shorten or simplify the story as needed for twos.
- Enlarge the felt board figures when you make the copies. This will help the children to see them better.
- Add any props that you think would enhance the story.

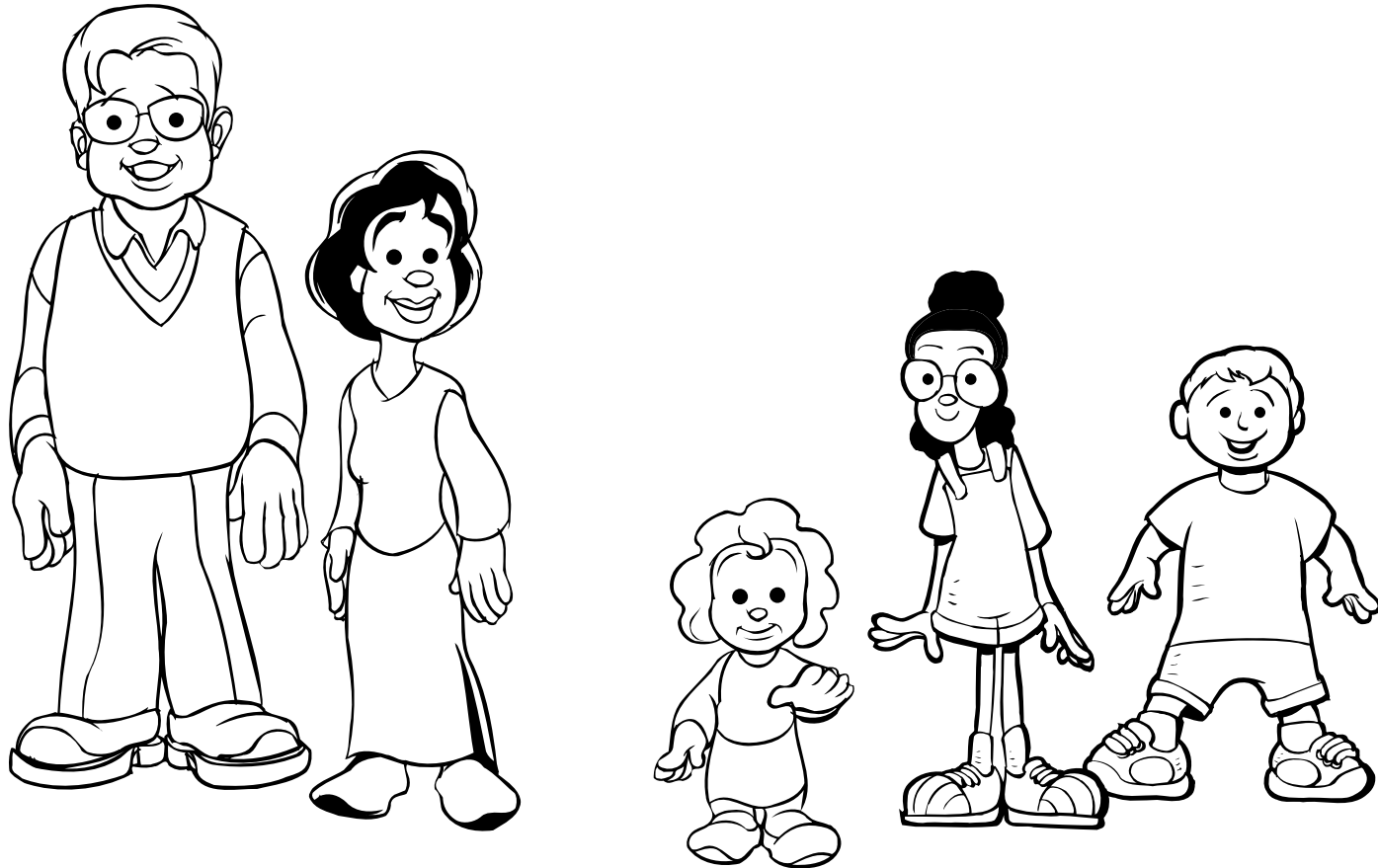

Do Not Be Afraid

Boat in the Storm

The children will make a boat to reinforce the lesson that Jesus calmed the storm.

Materials

For each child:

- 1 piece of light blue construction paper, 9" x 12"
- 1 piece of black construction paper, 9" x 12"
- 1 piece of yellow construction paper, 2" x 2"
- 1 cotton ball
- 1 gold pipe cleaner
- 4 brass fasteners
- 10 blue crepe paper squares, 2"
- 1 blue crepe paper streamer, 11"
- yarn, 12"
- glue stick
- crayons

For the teacher:

- brown construction paper, 1 piece for every 3 children
- scissors
- glue
- hole punch
- black marker

Reproducible Pages:

- Page D, 1 copy for the teacher
- Page E, 1 copy for each child

Preparation

1. Cut out the boat and sun stencils and the figures of Jesus and the disciples from the copies of Reproducible Pages D and E.
2. Trace and cut out two boats from brown construction paper and one sun from yellow construction paper for each child.
3. Make two boat pictures for each child as follows:
 - A. Glue the picture with Jesus sleeping onto one boat.
 - B. Attach the boat with a brass fastener 1½" up from the bottom and centered on the black construction paper. See Figure A.
 - C. Cut each pipe cleaner in half and bend them to look like lightning bolts. With the brass fastener straddling the pipe cleaner lightning bolt, (See Figure B) insert the brass fastener

through the black construction paper. Place one on each side of the boat. See Figure C.

- D. Glue the other picture with Jesus awake onto the other boat.
- E. Attach this boat with a brass fastener 1½" up from the bottom and centered on the blue construction paper.
4. Place the black paper on top of the blue paper and punch two holes, 3" from the corners and 1" from the top. See Figure C.
5. Cut the blue streamers into one 12" piece and eleven 2" squares for each child.
6. Cut one 18" piece of yarn for each child.
7. Make a model of the craft following the instructions.

Instructions

1. Show the children your model of the craft. Briefly tell the story. Starting with the first page tell of the storm and Jesus sleeping in the boat. Turn to the next page with Jesus standing up. *Wow! Jesus told the storm to stop, and it stopped! The storm obeyed right away!*
2. Give each child a prepared piece of black construction paper. Show the children how to rock the boat in the storm.
3. Put ten dots of glue across the bottom of each black sheet of paper and give each child ten squares of blue crepe paper to put onto the dots.
4. Give each child a prepared piece of blue construction paper. Write their names on the back.
5. Give each child a sun to glue above the boat on the blue paper.
6. Give each child a cotton ball. Have them pull it apart and glue it to the blue paper above the boat as clouds.
7. Run a small line of glue across the bottom of each piece of blue paper and help the children place a 11" piece of crepe paper on top of the glue as calm water.
8. After the glue has dried, place the black paper on top of the blue paper and thread the yarn through the two holes on the top, tying each end loosely to allow the pages to be turned.

Conclusion

Sing "Must Be Jesus" from the Unit 20 Song Sheet.



Do Not Be Afraid

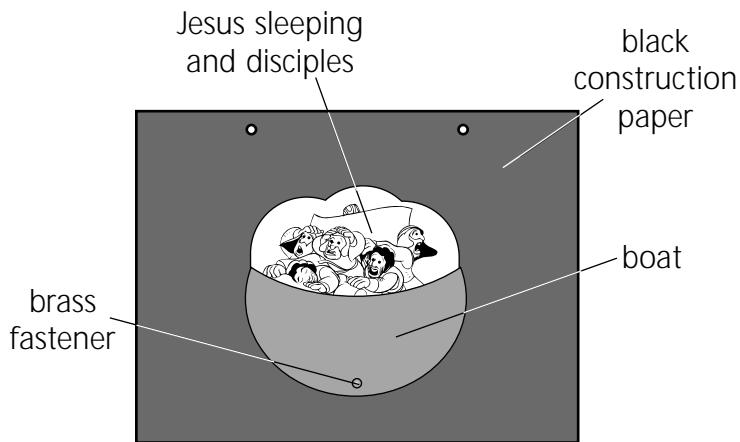

Figure A

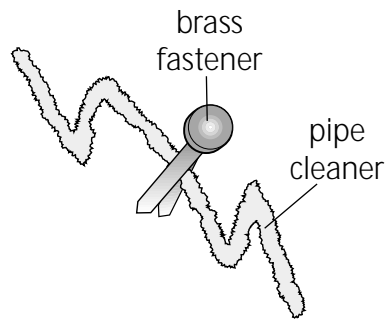

Figure B

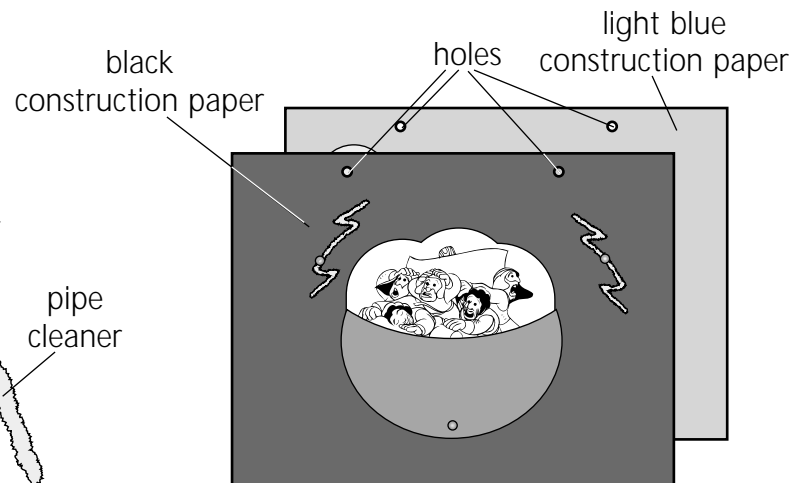
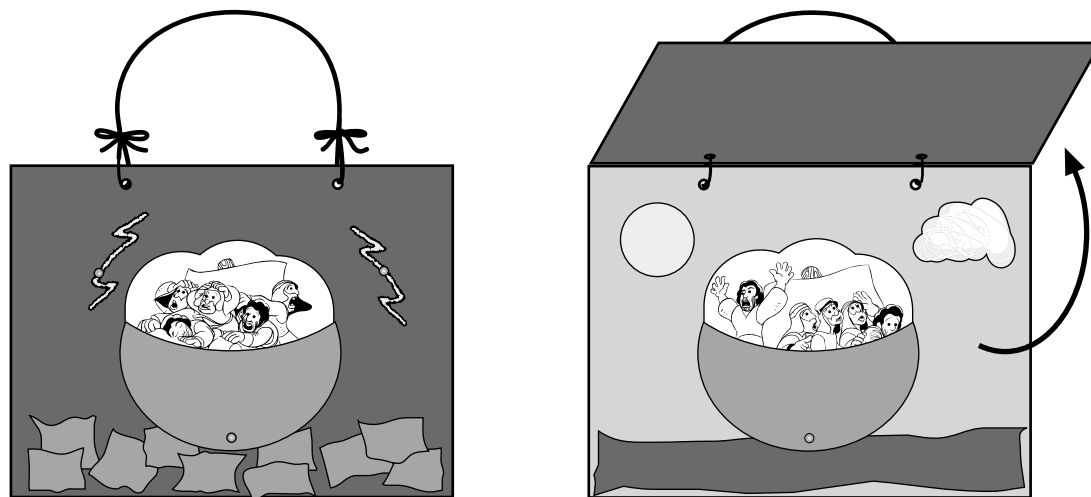

Figure C



Finished Craft





Do Not Be Afraid

Jesus Cares

Lesson 1

Lesson Objectives

- The children will role play Jesus calming the storm.
- The children will sing about not being afraid.
- The children will say, "Jesus cares for me."

Bible Story Text

Mark 4:35-41

Bible Truth

Jesus cares for me.
(1 Peter 5:7)

Preclass Centers

In the preclass centers children will use language, motor, and cognitive skills, learn to interact with peers and cooperate in small groups.

Select four centers to use this unit. Assign a teacher to set up and supervise each center with no more than six children.

Materials

IMPORTANT: Do not allow any small toys in the classroom. First check all toys for size. You can obtain a "safety cylinder" from a pediatrician. Any object that can fit into the cylinder is too small and could cause a child to choke.

- Housekeeping Center—2 washable dolls (of diverse ethnicity, e.g., black and white), play food, dishes and 2 small blankets

- Story Center—simple books with limited text (cardboard are the most sturdy and durable) and large pillows
- Block Center—set of large blocks, people, animal figures (plastic or wooden) and toy cars
- Puzzle Center—1 puzzle for each child (for twos each puzzle piece itself should be a complete familiar object, for threes most can complete a 20-piece puzzle). **NOTE:** A puzzle should have all the pieces. If a puzzle piece is lost, the entire puzzle should be thrown out.

Instructions

Guide the play in each center reinforcing the unit theme. Refer to the following example for help in directing play and asking relevant questions.

Set up the Housekeeping center as a boat. Have different children take turns rowing the boat and putting up pretend sails. Ask the children what they see in the water. Ask them what the weather is like. Ask them if they are afraid and reassure them that God is taking care of them.

Teacher Tips

- You may want to try other centers such as transportation, large motor or manipulative.
- Wear comfortable clothes suitable for sitting on the floor.

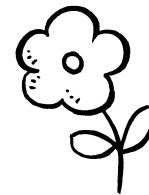

Lesson Plan

Greeting and Registration

Preclass Activity: Preclass Centers

Welcome and Singing

Centers:

Life Application: Shadow Game

Bible Story: No Fear

Craft: Windsock Boat

NOTE: Be sure to allow sufficient time for a snack.

Life

Application

Shadow Game

The children will play a game with shadows to show them that shadows are not scary.

Bible Truth

Jesus cares for me.
(1 Peter 5:7)

Materials

For the teacher:

- Bible
- table
- dark tablecloth or sheet to hang over the table
- 1 piece of white poster board
- masking tape
- bright flashlight, projector or lamp

Preparation

1. Before the children arrive set up the center area as follows:
 - A. Drape the tablecloth over the table so that it hangs to the floor on three sides.
 - B. Tape the piece of white poster board under the table as a movie screen.
 - C. Tape the flashlight to a chair and place it at the open end of the table so that it shines on the poster board.
 - D. Practice making shadows to be sure that you have the right amount of light.
2. Practice making different kinds of shadows with your hands.

Instructions

1. *Today we are going to make shadows. Who knows what a shadow is? Demonstrate a shadow for the children. Have you ever seen your own shadow when you were outside?*
2. *Make different types of shadows for the children. Some shadows look funny. Some shadows look scary. But we don't need to be scared of them because they are only shadows! Do you know who made shadows? God did!*
3. *Have the children make shadows with their hands.*
4. *Sing "Is It Scary?" from the Unit 20 Song Sheet. Role play the song as you sing it.*

Bible Truth Activity

Open the Bible. *The Bible says that I do not need to be afraid because Jesus cares for me. Can you say, "Jesus cares for me"?*

Ask each child if Jesus cares for them. Yes, he does! Jesus cares for each one of us.

Conclusion

Let's talk to God. Dear God, thank you for loving us and caring for us. We love you! In Jesus' name we pray. Amen.

Who are you going to tell about Bible class today? What are you going to tell them?

Teacher Tips

- Do the "Lion Hunt" from the Unit 20 Song Sheet to help keep the children's interest.
- **IMPORTANT:** Be very careful with your light source to make sure the children do not get hurt or burned.



No Fear

The children will hear the story of Jesus calming the storm. They will understand that Jesus takes care of them just as he took care of his disciples.

Bible Story Text

Mark 4:35-41

Materials

For the teacher:

- Bible
- fan (for wind)
- water spray bottle (for rain)
- 1 large piece of poster board (to make thunder)
- yellow crepe paper strips (for lightning)
- large blue sheet or tablecloth (for the sea)
- large box or laundry basket (for the boat) have enough for all the children in the small group to be seated inside one
- sheet
- scarf

Preparation

1. Before the children arrive set up the Bible Story area as follows:
 - A. Plug in the fan and place it where the children won't be able to reach it.
 - B. Spread out the blue sheet on the floor as the sea. Crumple the fabric to represent waves.
 - C. Place the boxes on the sheet as boats.
 - D. Drape the sheet over your shoulder and tie it at your waist with the scarf.
2. Fill the spray bottle with water.

Be Quiet!

As the children come into the center invite them to step into one of the boats. *Hello! Come in and sit down in our boat. Let's pretend this is the boat Jesus was in with his disciples. You pretend to be the disciples, and I will pretend to be Jesus.*

Open the Bible. *One day Jesus and his disciples were out in the boat. Jesus was very tired and he lay down and went to sleep. While he was sleeping, a storm started.*

Have you ever felt the wind blow really hard in a storm? Turn on the fan, so it blows on the children. Do you feel the wind blowing?

Have you ever been outside and gotten all wet from the rain? Hold out your hand, and feel the rain. Spray their hands with water from the spray bottle. The Bible says it started to rain. Then it started thundering. Give a child the poster board to shake to make sounds of thunder. And then the lightning started. Give two children yellow streamers. Have them stand up and shake the streamers to look like lightning.

How do you think the disciples felt? Do you think they felt scared? Yes, they were very scared. Have you ever been scared of a storm when the rain and thunder are very loud? Do you think Jesus was scared? Do you know what he was doing? Lie down on the floor and pretend to be asleep. He was sound asleep! He was not afraid at all.

The disciples woke him up saying, "Jesus, wake up! We are afraid of the storm!" Jesus woke up and looked around. Do you think he was afraid? Stand up, and hold out your arms. He just stood up and said to the storm, "Quiet! Be still!" (Mark 4:39).

Do you know what happened when he said this? The wind stopped! Turn off the fan. The rain stopped! Put away the spray bottle. The thunder stopped. Put away the poster board. The lightning stopped, put away the streamers, and the waves settled down on the lake. Smooth out the sheet. And everyone was safe!

Do you think the disciples felt happy? Yes, they were very happy! Jesus has so much power! He can tell a storm to stop and it obeys him right away. The Bible says, "Jesus cares for me." Can you say that? Jesus cares for me! I don't ever have to be afraid! Jesus is so strong, he cares for me and he always protects me!
Sing "Must Be Jesus" from the Unit 20 Song Sheet.

Do Not Be Afraid

Conclusion

Have the children answer the following questions to review the story:

- Who was asleep in the boat? (Jesus)
- What happened to the boat on the water? (it was caught in a storm)
- How did the disciples feel? (afraid)
- What did Jesus do about the storm? (he made it stop)
- Does Jesus care for you? (Yes!)

Teacher Tips

- **IMPORTANT:** Do not allow the children to get close to the fan or to the fan cord.

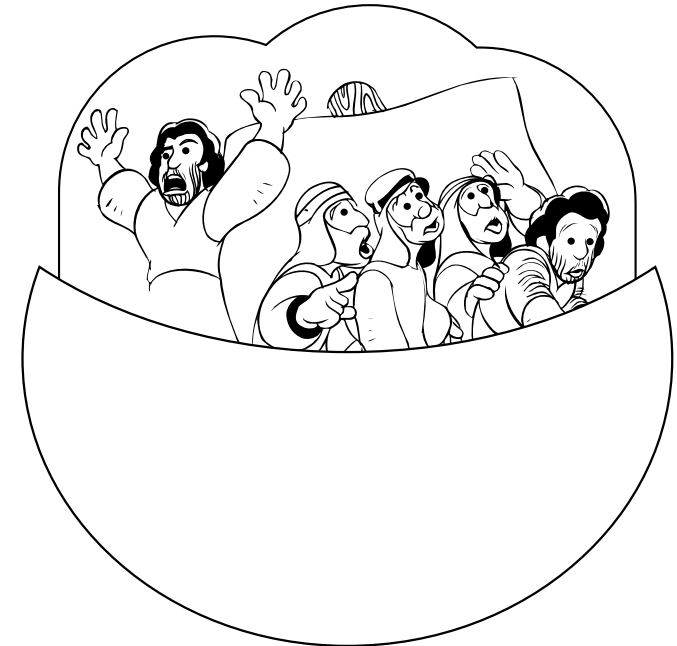
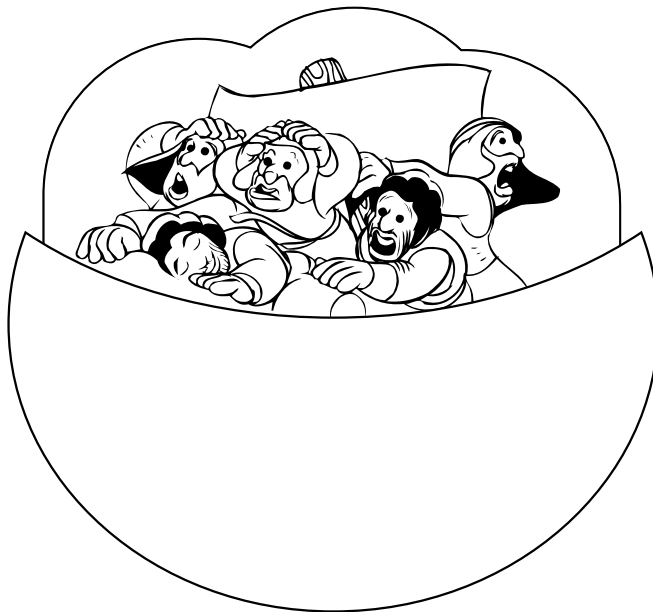

Windsock Boat

The children will make a windsock to remind them that Jesus calmed the storm.

Materials

For each child:

- ½ sheet of black construction paper, 4½" x 12"
- 1 piece of brown construction paper, 2½" x 4"
- 1 piece of white construction paper, 2½" x 2½"
- 3 pieces of silver curling ribbon, 12"
- 2 pieces of yarn, 12" and 18"
- 2 strips of blue crepe paper (streamers), 12"
- glue stick
- crayons

For the teacher:

- scissors
- tape
- hole punch
- stapler
- black marker
- hole reinforcers

Reproducible Pages:

- Page F, 1 copy for the teacher

Preparation

1. Prepare a piece of paper for each child as follows, see Figure A:
 - A. Cut a 4½" x 12" piece of black construction paper for each child.
 - B. Punch two holes at the top of the paper and place a hole reinforcer on each hole. Each hole should be 3½" in from the side of the paper and 1" down from the top.
 - C. Cut one 18" piece of yarn for each child.
 - D. Tie the yarn to the paper, one end in each hole as a handle.
2. Cut two 1½" x 12" pieces of crepe paper for each child.
3. Cut each 12" piece of crepe paper in half lengthwise making them ¾" x 12".
4. Cut two 12" pieces of silver ribbon for each child. Curl each piece.
5. Cut out the stencils from the copy of Reproducible Page F.

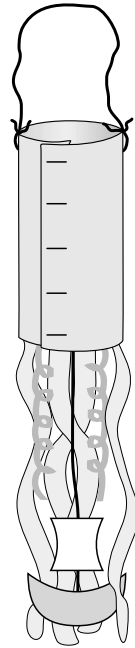

6. Make a boat for each child as follows, see Figure B:
 - A. Trace and cut out a boat from brown construction paper.
 - B. Trace and cut out a sail from white construction paper.
 - C. Cut a 12" piece of yarn for each child.
 - D. Tape the boat to the end of the yarn.
 - E. Tape the sail to the yarn 1" above the boat. NOTE: for stability, tape the yarn down completely to the back of the sail.
7. Make a model of the craft following the instructions.

Instructions

1. Show the children the sample craft. Gently blow on the boat so that it sways. Give each child a turn. *When we blow on the boat it is like the wind in a storm. Then Jesus says, "Stop, wind!" And guess what happens? The wind stops. Let's make a windsock boat for you to take home!*
2. Give each child a prepared piece of construction paper. Help each child to draw a line of glue with a glue stick across the bottom of the paper, leaving 1" margins at the short ends.
3. Give each child a piece of yarn with the boat attached. Help each child to affix the free end of the yarn on the glue in the center of the paper. See Figure C.
4. Give each child two pieces of silver ribbon as "lightning." Help each child to affix one end of each piece of ribbon, shiny side down, in the glue on either side of the yarn.
5. Give each child four pieces of crepe paper for "rain." Help each child to place two pieces of crepe paper on either side of the paper in the glue.
6. Place a long piece of tape across each piece of crepe paper, ribbon and yarn to hold them in place. See Figure D.
7. Help each child to curl the paper around so that the ends overlap. Staple the ends together. See Figure E.
8. Write each child's name on their craft.

Conclusion

Let's all pretend the storm is coming. Blow your boat and your water! Wow! Look at those storms blowing! Now pretend you are Jesus. Say, "Stop, storm!" What happened? The storms stopped blowing! Jesus is so powerful, isn't he?

Sing "Must Be Jesus" from Unit 20 Song Sheet.

Do Not Be Afraid

Craft

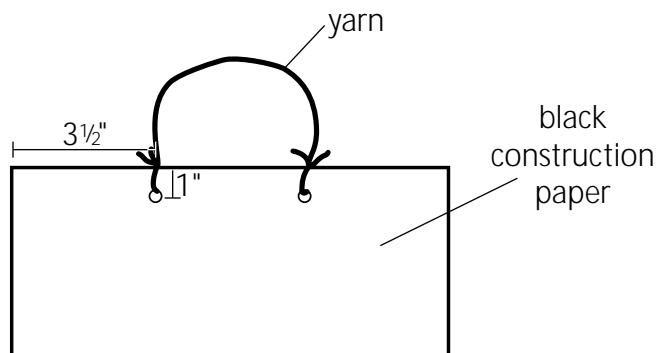

Figure A

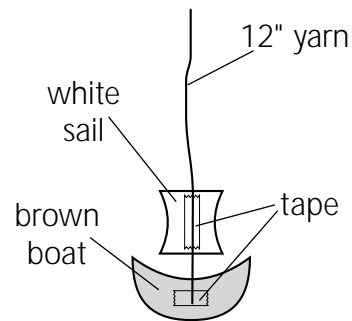

Figure B

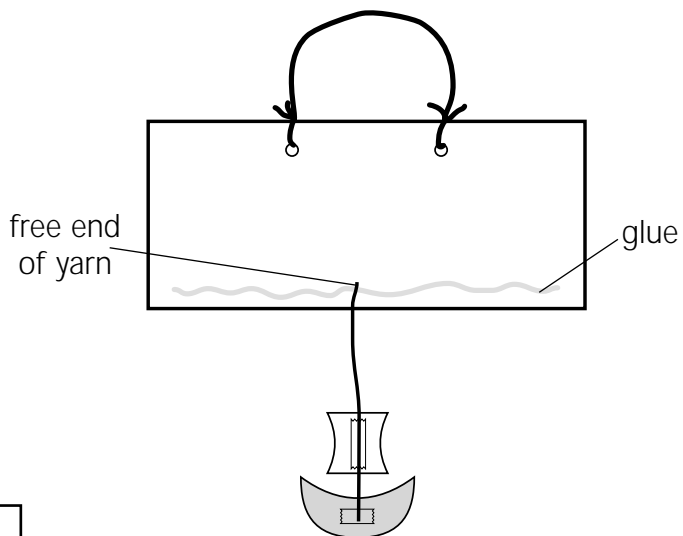

Figure C

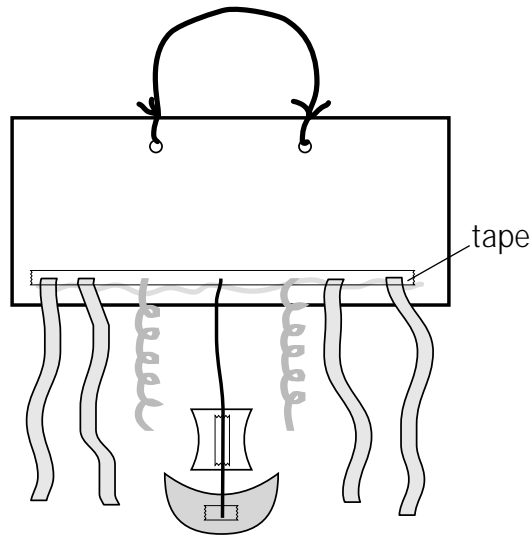

Figure D

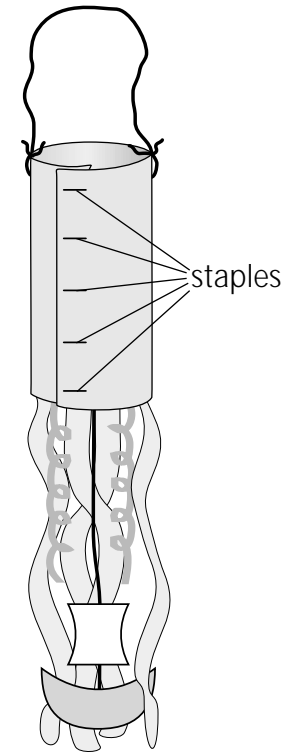

Figure E





R
e
p
r
o
d
u
c
e
-
b
-
c
-
u
-
c
-
i
-
o
-
n
-
l
y



Barry



Debbie



baby Sarah

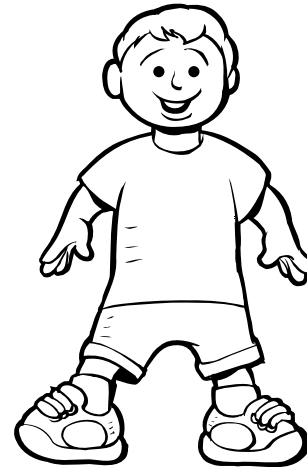

David



Lesli





R
E
P
R
E
S
E
N
T
A
T
I
O
N

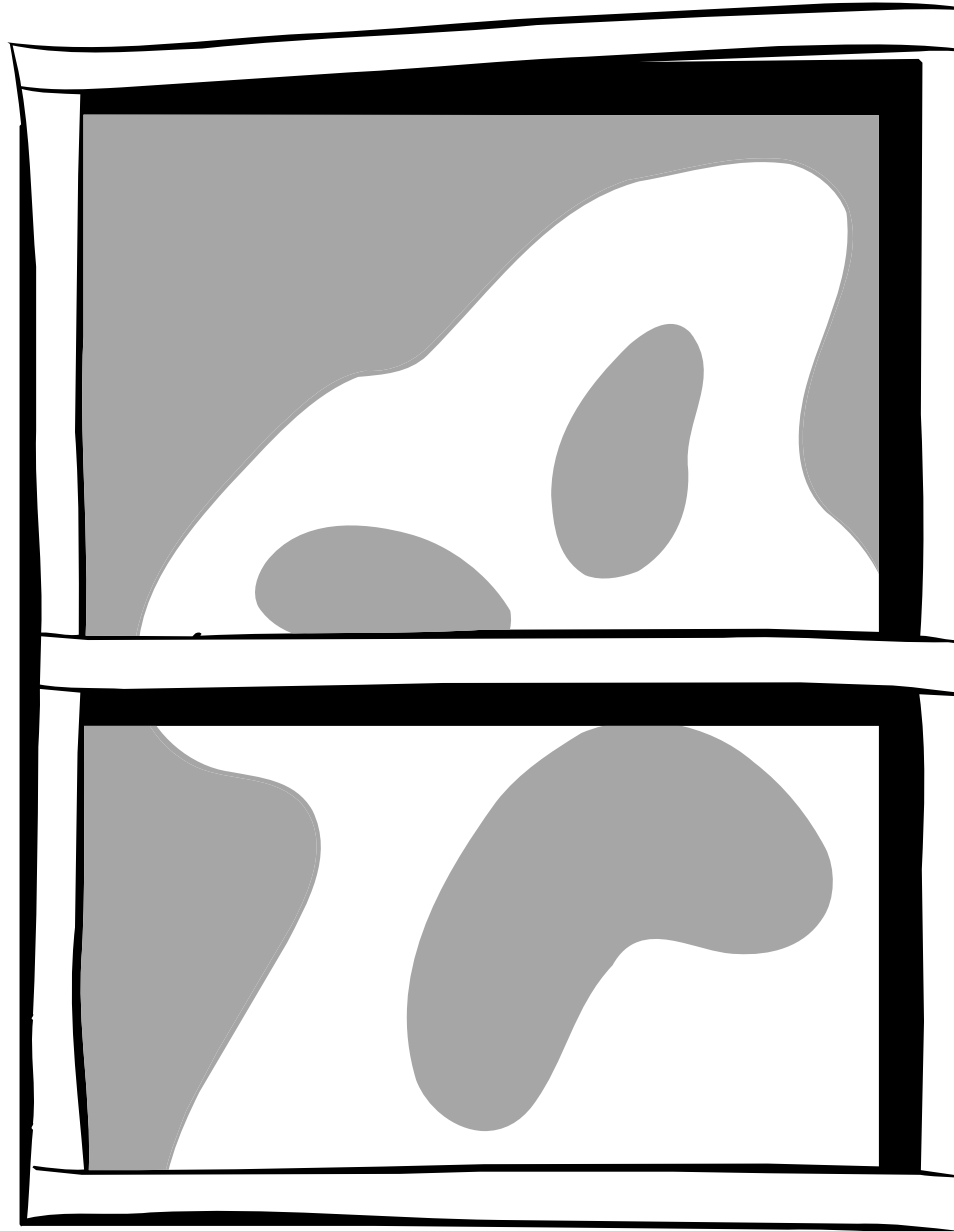

shadow window





R
E
P
O
R
T
E
R
S
O
F
F
A
I
T
H

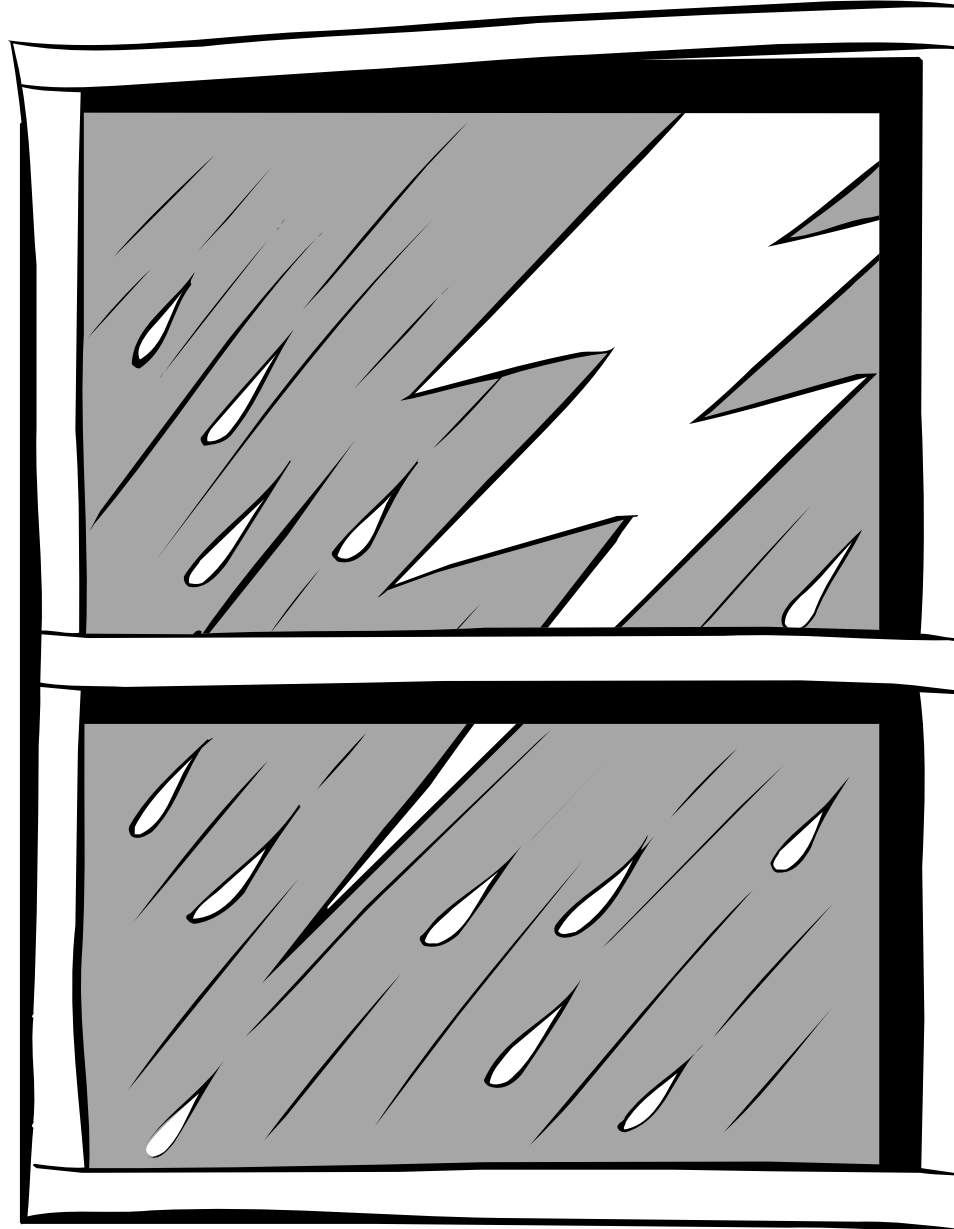

storm window





R
e
p
r
o
d
u
c
e
d
i
c
e
s

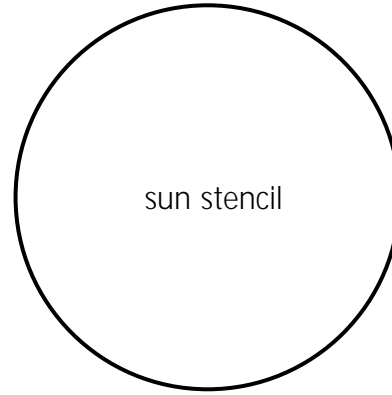

sun stencil

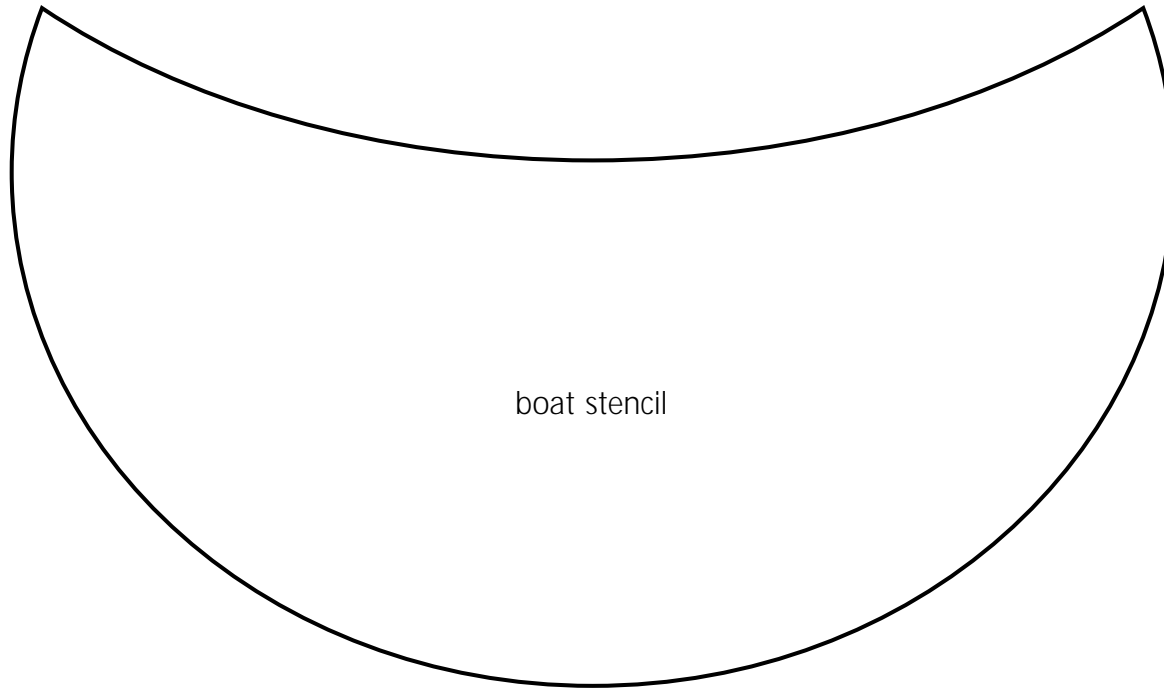

boat stencil





E-b-b-r-r

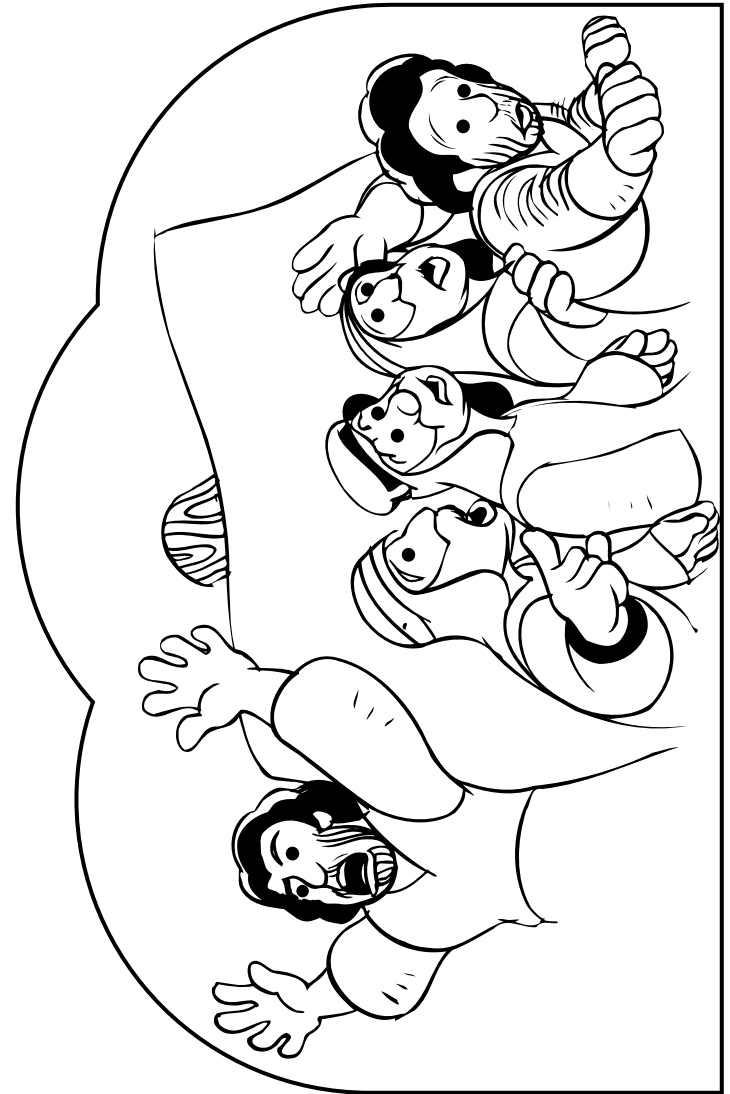
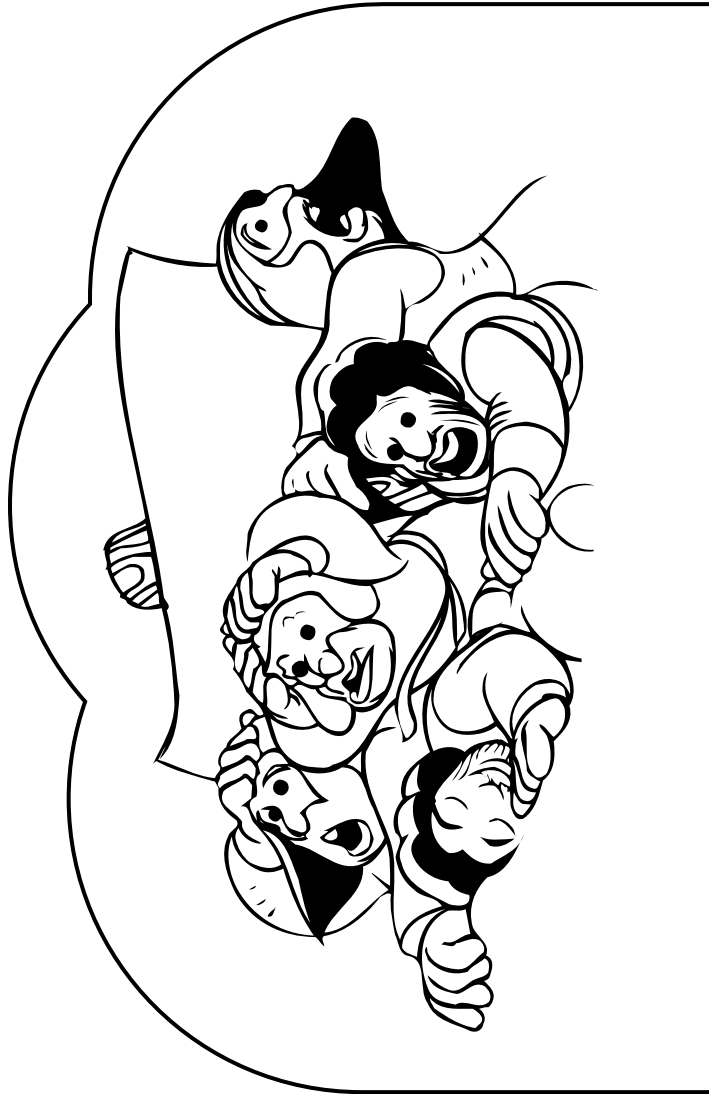

Figures of Jesus and the disciples





R
E
P
R
O
D
U
C
E
D
I
N
G

