

# Athens

## Missions

### Lesson 5

#### Lesson Objectives

- The children will describe Paul as a man who cared about people and taught them how to love God.
- The children will state that God wants them to love him more than anything else.
- The children will name things that God uses to help us have a relationship with him.

#### Lesson Text

Acts 17:16-34

#### Scripture Memory Verse

The Bereans were of noble character, for they received the message with great eagerness and examined the Scriptures every day.

*Acts 17:11*

#### Lesson Plan

Greeting and Registration

Preclass Activity: Signs

Welcome and Singing

Centers:

Bible Story: Paul in Athens

Life Application: We're Special

Craft: God Created Us

NOTE: Be sure to allow sufficient time for a snack.

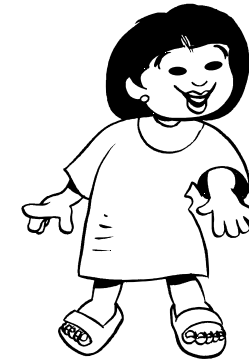

## Pre class



# Athens

## Signs

The children will make signs for the Bible Story Center.

## Materials

*For each child:*

- 1 piece of construction paper
- markers or crayons

*For the teacher:*

- small statues or figures of wood or stone

## Preparation

Draw a picture of the sun on a piece of construction paper.

## Instructions

1. Explain to the children that during the time of today's Bible Story the people worshiped many things. Show them the picture of the sun and explain that some people worshiped the sun. Ask them what other things they think people might have worshiped (animals, moon, sky, trees, etc.) Show the children the statues and explain that people worshiped statues too. Explain that the pictures are going to be used in the Bible Story.
2. Give each child a piece of paper and have them draw a picture of something that they think people may have worshiped.
3. Ask each child to tell you about the picture they are drawing and write a description at the bottom of the picture.
4. Give the pictures to the Bible Story teacher.

## Missions

### Lesson 5

## Conclusion

As they finish, talk to the children about how they are going to learn about how God wants everyone to worship him and be close to him. He does not want us to worship statues or other idols.

## Teacher Tips

- Do not bring in any religious statues. It would be inappropriate for this age.
- Some children may need help with an idea of what to draw.

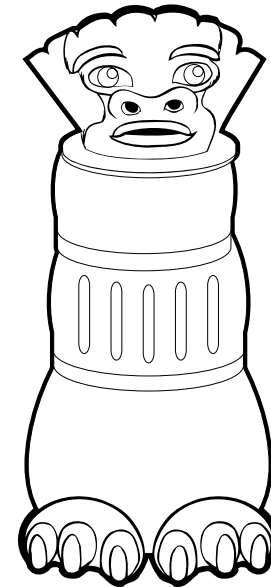

# Athens

## Paul in Athens

The children will hear about Paul and his love for God.

### Lesson Text

Acts 17:16-34

### Materials

For the teacher:

- pictures from the Preclass Activity
- a desk or chair
- 1 piece of construction paper, 9" x 12"
- marker
- tape
- Bible
- robe and/or scarf

### Preparation

1. On the piece of construction paper write, "To an unknown god."
2. Before the children arrive tape the different pictures around the area. Tape the sign "To an unknown god" near you.
3. Dress as Paul in a robe and scarf with a Bible in hand.

### Idols

Walk around the different pictures, *Gosh! Here I am in this city called Athens. Do you see all these statues? I am really worried. These people think that these things like the sun and the moon are gods! My name is Paul. It is so sad to see all of these different statues. The people that live here love to worship all different kinds of things but they don't worship God. They don't even know who God is. Look at this statue of a sun god! But my God made the sun! The sun is not God! The sun does whatever God wants it to do! Why do they worship the sun as if it were God?*

Go around to the other pictures in the same way. Look puzzled and distressed. Then turn toward the children and say, *are any of these statues God? No! God is not a statue that never moves or feels or cares or loves! God is not the sun; he made the sun! He is bigger than the sun or the moon or the ocean! How can I help the people in Athens learn about our God?* Have the children answer.

*I want them to know how much God loves them. Oh! I must pray and ask God to help me! I must help these people and teach*

*them about the real God who loves and cares for them. Will you pray with me?* Pray with the children. Pray identifying that you are Paul and for God to give you the love and boldness and courage to speak to these people about him.

*Wow! That prayer we prayed earlier really helped. I just got back from teaching people in a few other towns about Jesus and about God. Some of the leaders in the town wanted to hear what I had to say about God so I went to one of their meetings. I told them that they were very religious and that they worshiped lots of things that they shouldn't. I pointed out that they even had an altar for any gods that they might not know about.*

*Then I told them about God. That God is the only one we should worship and love and obey. I started teaching them that God made the world and everything that is in heaven and on earth (Acts 17:24). He can never be a statue; he gave each one of us our life and our breath. God decided when and exactly where people would live. And he did this so that people would love him (Acts 17:27). He is not a statue that does not feel or care. No! He made each of us so that we could find him and know him as his friend.*

*The people listened. Some of them did not like what I said and they did not want to believe me. They made fun of me. But others asked if they could hear more. They wanted to learn and listen to learn more about God! That made God happy and it made me happy too. Many people are going to become Christians here in Athens.*

### Conclusion

Ask the following questions to review the story:

What city did Paul visit? (Athens)

What did Paul see when he came to the city of Athens?

(statues of gods)

How did he feel about what he saw? (He was sad.)

Why do you think he felt sad? (He wanted the people to know God.)

What did he do about it? (He taught the people about God.)

Help them see that Paul wanted the people to know about God and how much God cared about them.

### Teacher Tips

- Make your own statues instead of using the pictures that the children drew.



# Athens

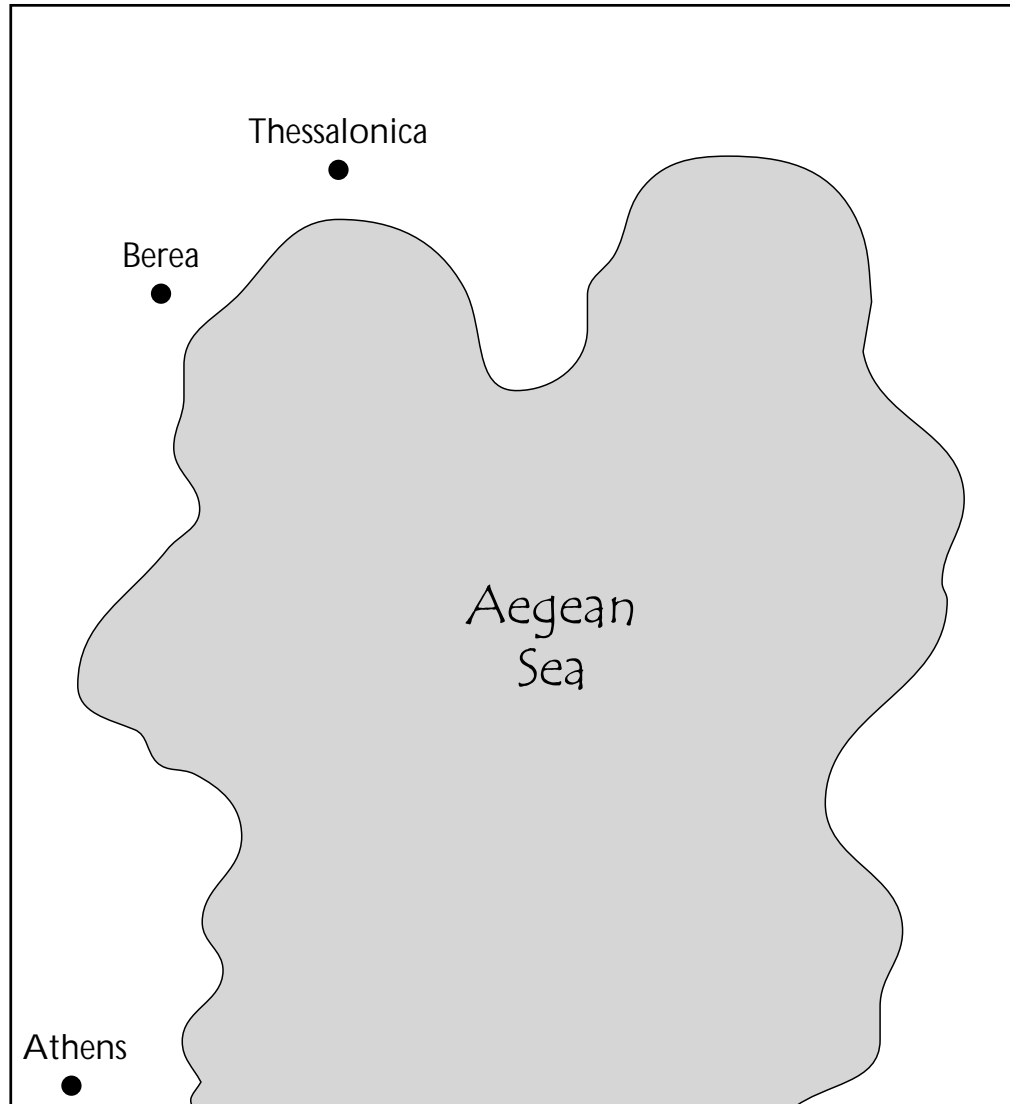

## We're Special

The children will learn that God wants to be the one that they love the most.

### Scripture Memory Verse

The Bereans were of noble character, for they received the message with great eagerness and examined the Scriptures every day.

*Acts 17:11*

### Materials

*For the teacher:*

- bag or pillow case
- various items: toy car, book, ball, picture of people, etc.
- Bible

### Preparation

1. Place all of the items in the bag.
2. Familiarize yourself with the activity.

### Instructions

Seat the children in a circle. *This week we are learning that God wants us to know him and love him. He wants us to love him more than anything else in the whole world.*

Show the children the bag and explain that inside there are things that we might think are special. Take out one of the items. *This is a ball. Who loves to play ball? Many people love to play ball. Some grown-ups play ball and make lots of money; they play basketball and football and baseball. But a ball is not more important than God. I love God more than a ball.*

Choose a child to reach in the bag and pull out another item. Have them tell the group what it is and if they like the item. Elaborate on the item as you did with the ball. Then ask the child if God wants them to love the item more than him.

Give each child a turn. When a child pulls out the Bible discuss that God wants us to love the Bible because it helps us to know him.

### Scripture Memory Activity

Choose a child who is confident to recite the verse. Then ask each child, *Who do you love the most?* (God) After each child answers have them recite the verse.

### Conclusion

*God wants us to teach our friends to love him too. What are some ways that we can teach our friends to love God?* (invite them to Bible class, show them the Bible, pray with them, be kind to them, be loving and share with them)

Pray with the children asking God to help you all to love him more than you love anything else.

### Teacher Tips

- Choose items that are special and important to the children.
- Be sure that the children understand that it is okay for them to love things other than God, but that God wants us to love him the most, more than all the other things.

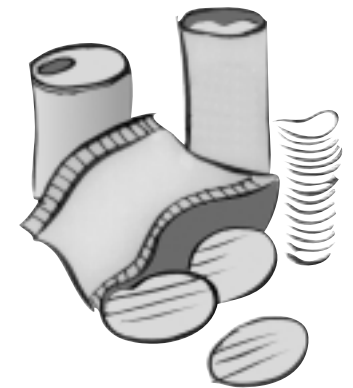

# Athens

Life

A  
P  
P  
L  
I  
C  
A  
T  
I  
O  
N

The Bereans were of noble character, for they received the message with great eagerness and examined the Scriptures every day.

Acts 17:11



## Athens

### God Created Us

The children will make a craft of the world to remind them that God created them and decided where they would live.

#### Materials

*For each child:*

- crayons or markers
- 1 piece of blue construction paper, 9" x 12"
- 1 piece of green construction paper, 9" x 12"
- 1 piece of yellow construction paper 9" x 12"
- glue stick

*For the teacher:*

- scissors
- paper

*Reproducible Pages:*

- Page A, 1 copy for the teacher
- Page B, 1 copy for each child

#### Preparation

1. Cut out the circle stencil from the copy of Reproducible Page A.
2. Trace and cut out one circle for each child from blue construction paper.
3. Cut out the children figures from the copies of Reproducible Page B.
4. Write "God made us to love him." on the top of each piece of yellow construction paper.
5. Make a model of the craft following the instructions.

#### Instructions

1. Show the children your model. Explain to them that they are learning that God made the world and everyone in it. He puts the people in certain places in the world because he hopes that they will want a relationship with him.
2. Give each child a piece of green construction paper. Have them rip the paper into small pieces. They will need five pieces about 3" x 2".
3. Give each child a circle. Have them glue the 5 pieces of green construction paper onto the circles creating a "world."
4. Give each child five children figures to color.
5. Have the children glue the figures onto the world.

6. Have each child glue their world onto the yellow construction paper.
7. Have the children write their names on their crafts.

#### Conclusion

Talk about how God made man to live on the earth and he picked exactly where each one of them should live. He chose to have some people live in Spain and some people live in China. He put people all over the world so that they would love him and help others to love him.

#### Teacher Tips

- Give the children foil stars to put on the construction paper around the world.

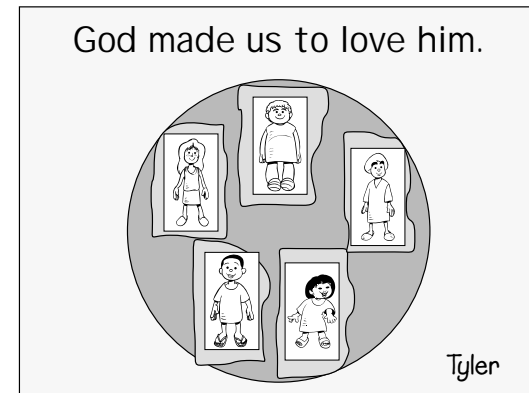

God made us to love him.

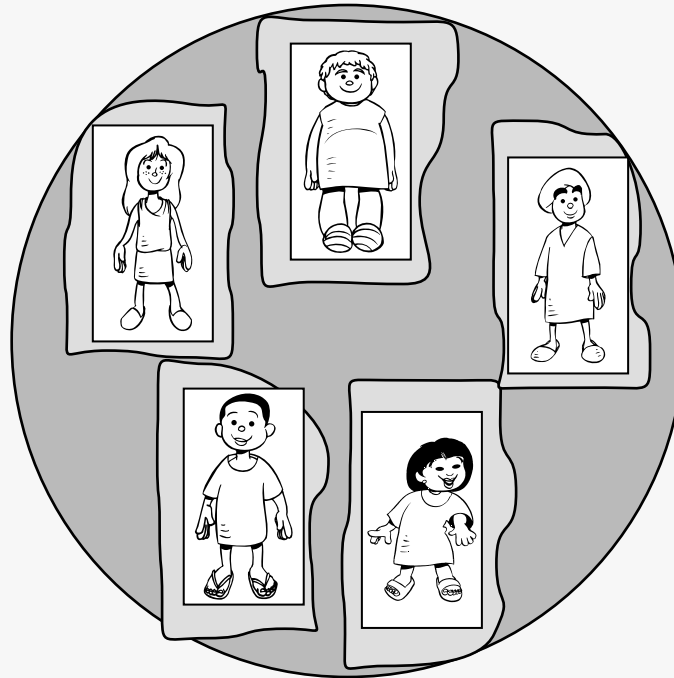

Tyler

Finished Craft





Pre class



### Lesson Objectives

- The children will describe Paul as a man who cared about people and taught them how to love God.
- The children will state that God wants them to love him more than anything else.
- The children will name things that God uses to help us have a relationship with him.

### Lesson Text

Acts 17:16-34

### Scripture Memory Verse

The Bereans were of noble character, for they received the message with great eagerness and examined the Scriptures every day.

Acts 17:11

### Puzzle Plate-1

The children will begin to make the puzzle for the craft.

#### Materials

*For each child:*

- scissors
- 1 thin paper plate
- glue stick

*For the teacher:*

- magazines (religious)

#### Preparation

1. Tear pages out of magazines that have pictures of things that we can use to seek and reach out for God. For example: ears, moms, dads, teachers, Bibles, friends, and possibly a picture of someone praying.

#### Instructions

1. Remind the children that they are learning about Paul and how he taught the people in Athens about God. They were very religious but they did not know about God. God wants all of us to know him. Talk with them about different ways that we learn about God. Who teaches you about God? (mommy, daddy, brother, sister, friend, teacher)
2. Have the children cut or tear out pictures that represent the ideas that you discussed.
3. Give each child a paper plate and have them glue the pictures onto the back of the plate.
4. Have the children put their names on their plates.
5. Give the plates to the Craft teacher.

### Lesson Plan

Greeting and Registration

Preclass Activity: Puzzle Plate-1

Welcome and Singing

Centers:

Game: Hide and Seek

Craft: Puzzle Plate-2

Life Application: We're Special

NOTE: Be sure to allow sufficient time for a snack.

#### Conclusion

Ask the children who finish early to glue pictures onto plates for the Game Center. Each plate should have one type of picture on it, for example, a plate with only ears or a plate with only Bibles. Give these plates to the Game Center teacher.

#### Teacher Tips

- Make extra plates for the Game Center to ensure that there is one for each child in the small group.





## Hide and Seek

The children will play a game that helps them to remember that God wants them to love him.

### Materials

*For the teacher:*

- plates from the Preclass Activity



### Preparation

Hide the plates from the Preclass Activity around the room. Hide them in places where they will be easy to find.



### Instructions

1. Have the children sit in a circle. Explain to them that there are paper plates hidden around the room. These paper plates have pictures on them of people or things that help us to know God. Their job is to each find one plate.
2. Choose a child to go first. Have the child find a plate and return to the group.
3. Have the child describe the pictures that are on the plate and explain how that item helps people to know God.
4. Allow each child to have a turn.



### Conclusion

Talk to the children about how God is very happy when we want to have a relationship with him. He wants us to be his friend and be with him forever.

### Teacher Tips

- Continue playing as time permits.



CRAFT



## Puzzle Plate-2

The children will make a puzzle about ways to seek and reach out for God.

### Materials

*For each child:*

- paper plate from the Preclass Activity
- crayons or markers
- glue stick
- scissors

*For the teacher:*

- scissors

*Reproducible Pages:*

- Page C, 1 copy for every 5 children

### Preparation

1. Cut out the text boxes from the copies of Reproducible Page C.
2. Make a model of the craft following the instructions.

### Instructions

1. Show the children the finished craft and explain that they will make a puzzle of the different things that God uses to help us to know him.
2. Give each child a text box and have them glue it onto the front of the plate.
3. *Where can we read about God?* (the Bible) Have the children draw a picture of the Bible on the front of their plates. Then have them draw a picture of themselves listening to the Bible.
4. Have the children cut their plates into three pieces.
5. Have the children practice putting their puzzles back together.
6. Have them try to put each other's puzzles together.

### Conclusion

Ask the children to tell the group about the pictures that they drew for their plates.

### Teacher Tips

- Have the children use glitter, stickers, etc. to decorate their plates.

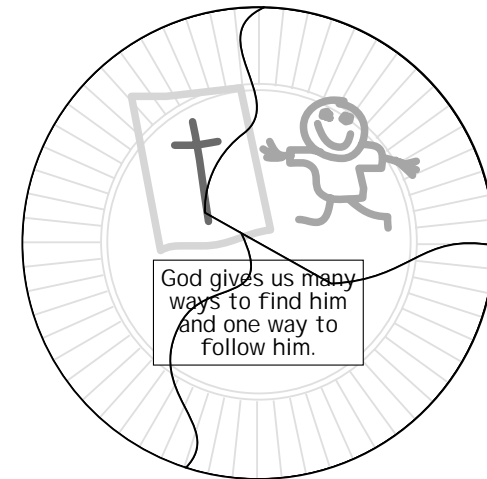

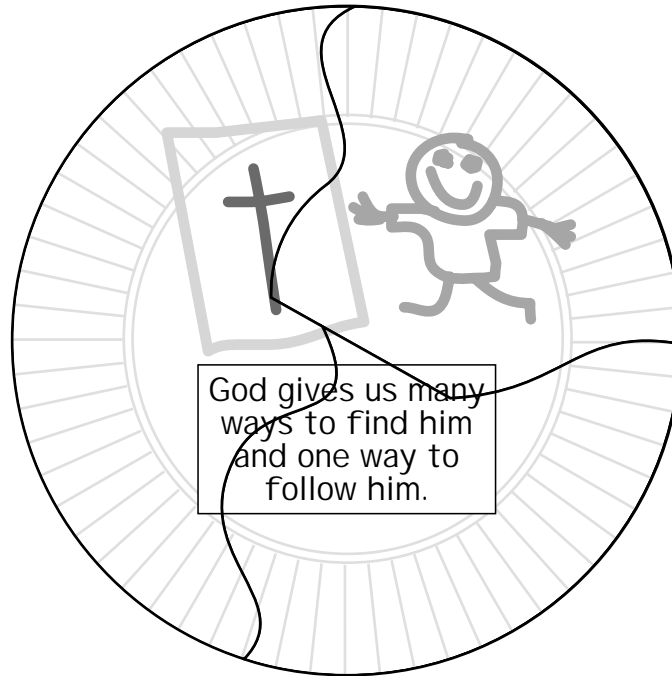

Finished Craft



## We're Special

The children will learn that God wants to be the one that they love the most.

### Scripture Memory Verse

The Bereans were of noble character, for they received the message with great eagerness and examined the Scriptures every day.

*Acts 17:11*

### Materials

*For the teacher:*

- bag or pillow case
- various items: toy car, book, ball, picture of people, etc.
- Bible

### Preparation

1. Place all of the items in the bag.
2. Familiarize yourself with the activity.

### Instructions

Seat the children in a circle. *This week we are learning that God wants us to know him and love him. He wants us to love him more than anything else in the whole world.*

Show the children the bag and explain that inside there are things that we might think are special. Take out one of the items. *This is a ball. Who loves to play ball? Many people love to play ball. Some grown-ups play ball and make lots of money; they play basketball and football and baseball. But a ball is not more important than God. I love God more than a ball.*

Choose a child to reach in the bag and pull out another item. Have them tell the group what it is and if they like the item. Elaborate on the item as you did with the ball. Then ask the child if God wants them to love the item more than him.

Give each child a turn. When a child pulls out the Bible discuss that God wants us to love the Bible because it helps us to know him.

### Scripture Memory Activity

Choose a child who is confident to recite the verse. Then ask each child, *Who do you love the most?* (God) After each child answers have them recite the verse.

### Conclusion

*God wants us to teach our friends to love him too. What are some ways that we can teach our friends to love God?* (invite them to Bible class, show them the Bible, pray with them, be kind to them, be loving and share with them)

Pray with the children asking God to help you all to love him more than anything else.

### Teacher Tips

- Choose items that are special and important to the children.
- Be sure that the children understand that it is okay for them to love things other than God, but that God wants us to love him the most, more than all the other things.

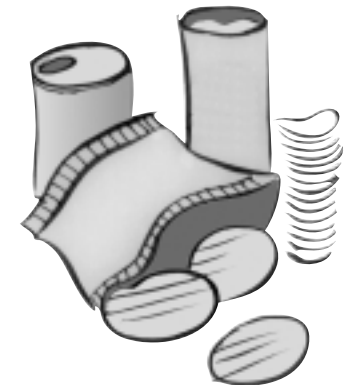

The Bereans were of noble character, for they received the message with great eagerness and examined the Scriptures every day.

Acts 17:11



Core/Craft  
1 copy for the teacher

Pre-Preparation

Page

**A**

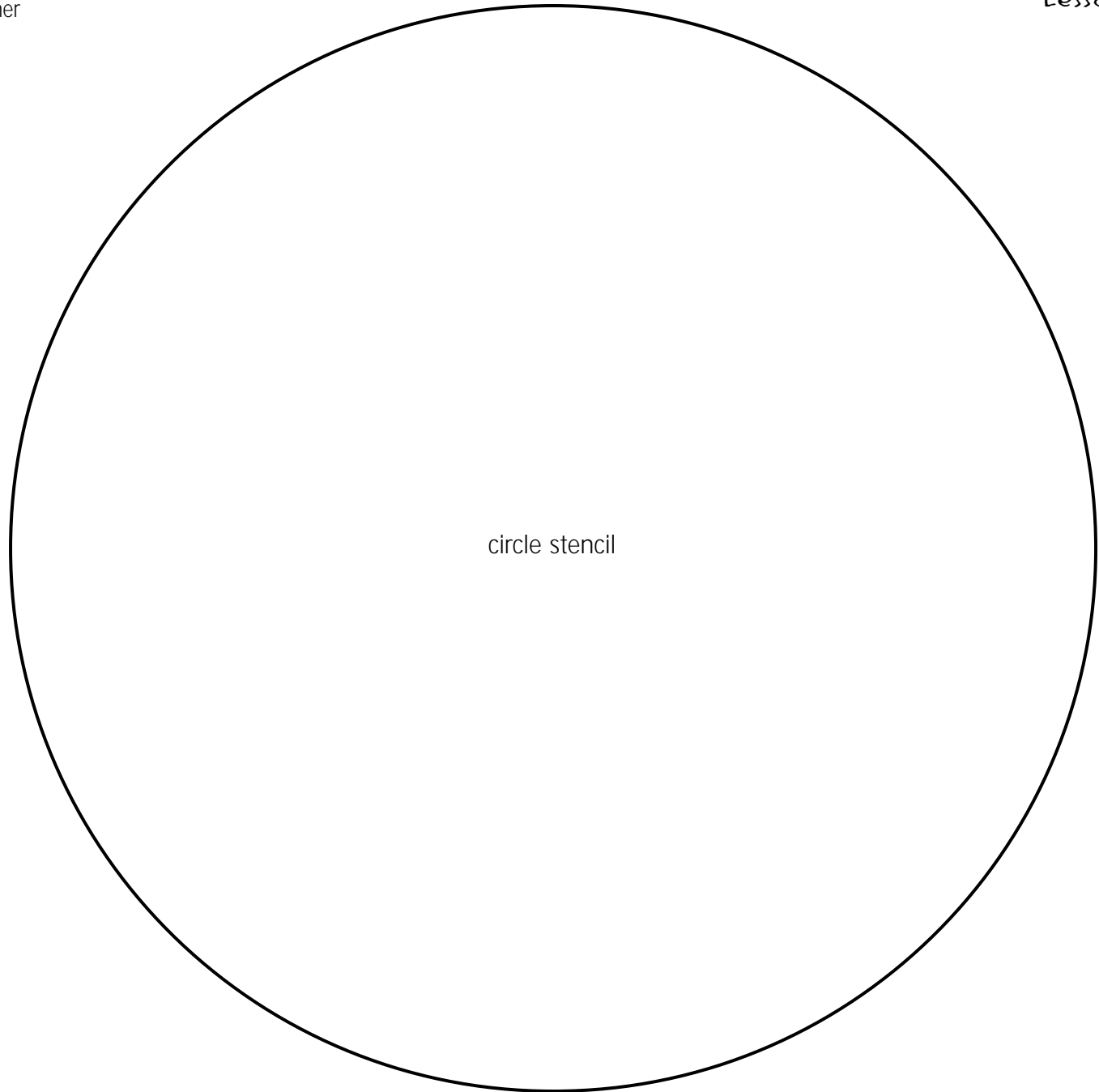

circle stencil



Core/Craft  
1 copy for each child

REPRODUCTION

Page

B

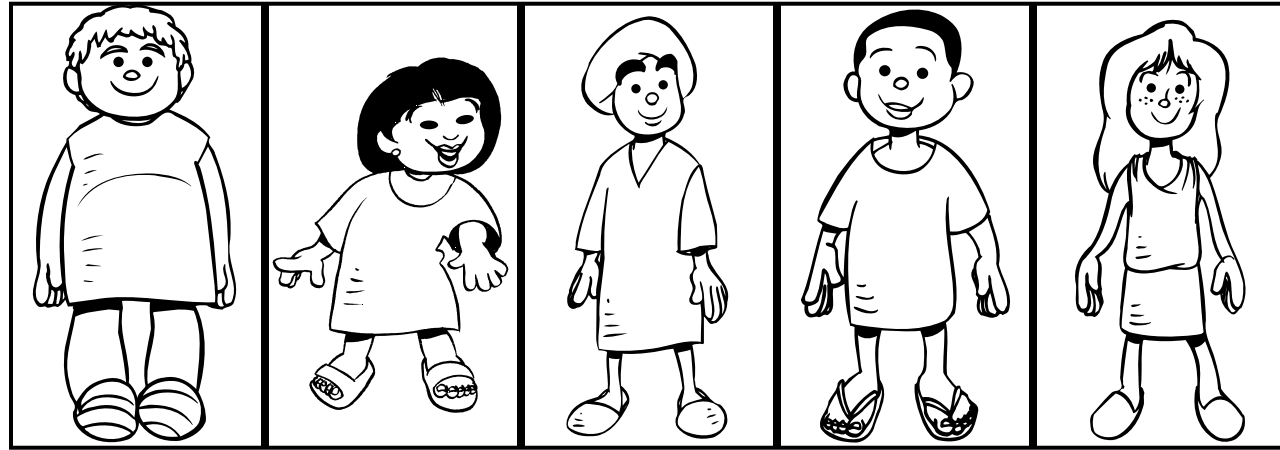



Supplement/Craft

1 copy for every 5 children

READER

Page

C

God gives us many ways to find him and one way to follow him.

God gives us many ways to find him and one way to follow him.

God gives us many ways to find him and one way to follow him.

God gives us many ways to find him and one way to follow him.

God gives us many ways to find him and one way to follow him.

