

# The Red Sea

## Lesson Objectives

- The children will say "the Red Sea" when asked what sea God parted so that Moses and the people could walk through.
- The children will role play following Moses.
- The children will state that God takes care of his people.

## Bible Story Text

Exodus 13:21, 22; 14:21, 22

## Bible Truth

We listen to God.  
(Proverbs 1:33)

## Lesson Plan

Greeting and Registration

Preclass Activity: Preclass Centers

Welcome and Singing

Centers:

Bible Story: The Crossing

Life Application: Moses, May I?

Craft: Crossing the Red Sea

NOTE: Be sure to allow sufficient time for a snack.



# The Red Sea

## Preclass Centers

As the children arrive, guide them to a preclass center. Have no more than six children at each center.

### Materials

Use the materials previously selected for this unit's preclass centers.

### Preparation

1. Be sure to check the condition of the materials selected for this unit's preclass centers prior to set up. Replace any broken toys, or puzzles with missing pieces as necessary.
2. Set up the centers before the children come into the classroom.
3. Assign a teacher to each center and have the teachers stay in those centers until the singing begins.

### Instructions

Guide the play in each center reinforcing the unit theme.

### Teacher Tips

- **IMPORTANT:** Do not allow any small toys in the classroom. First check all toys for size. You can obtain a "safety cylinder" from a pediatrician. Any object that can fit into the cylinder is too small and could cause a child to choke.
- Be involved in the group play and offer guidance as needed.
- Wear comfortable clothes suitable for sitting on the floor.
- Smile! Be childlike in heart and alert in mind.



# The Red Sea

## The Crossing

The children will learn that Moses listened to God. He obeyed him and led the people out of Egypt.

### Bible Story Text

Exodus 13:21, 22; 14:21, 22

### Materials

For the teacher:

- Bible
- Moses figure and sandals from the Unit 18 Lesson 1, Bible Story
- 'Crossing the Red Sea' prop from the Craft teacher
- felt board
- sand, pebbles, small shells
- glue
- scissors
- crayons or markers
- tape
- paint stick

Reproducible Pages:

- Page A, 1 copy for the teacher
- Page B, 1 copy for the teacher

### Preparation

1. Cut out and color one of the 'Moses and the people' pictures from the copy of Reproducible Page A as a felt board figure.
2. Glue Moses' sandals on his feet.
3. Roll two pieces of tape and place them on the backs of the Moses figure and the 'Moses and the people' figure.
4. Make the cloud and fire on a stick as follows:
  - A. Cut out the pillar stencil from the copy of Reproducible Page B.
  - B. Trace and cut out two pillar shapes.
  - C. Color one shape with red, orange and yellow crayons as fire.
  - D. Glue cotton balls to the other pillar shape as clouds.
  - E. Glue the two pillars back to back with the paint stick in between.
5. Before the children arrive in class, put some sand and small pebbles on the dry land of the 'Crossing the Red Sea' prop.

## Moses

### Lesson 3

### Parting of the Red Sea

Place the Moses figure on the felt board. Hello, children! Do you know who I am? My name is Moses. Have the children say hello to Moses. Open the Bible. Does anyone remember how God spoke to me? That's right, in the burning bush! Do you remember what God told me to do? He told me to go and lead his people out of Egypt to a new land (Exodus 3:1-10). Did I go? Yes, I did! I listened to God, and I obeyed him!

The Bible says that God always takes care of us when we listen to him and obey him. Do you think he took care of the people of Egypt and me? Yes, he did! The Bible says that we got all of our things ready to leave Egypt. All of the people got their children, their animals and everything they had ready to go (Exodus 12:37-39). Replace the Moses figure with the 'Moses and the people' figure on the felt board.

How would we know which way to go? How would we find the new land that God had for us? To help us, God put a special cloud in the sky to lead us during the daytime. Show the cloud on the stick. At night we could not see the cloud because it was too dark, so God put a pillar of fire in the sky (Exodus 13:21). We had light to see where to go, day or night. Turn the stick around and show the pillar of fire.

We traveled for a few days, following the cloud by day and the fire by night. Move the stick and follow it with the felt board picture. We knew that God was leading us to the new land. We were very happy!

But one day, we had a problem, and we were not so happy. We did not know what to do. We came to the edge of a big sea. It was called the Red Sea. There was no way we could go across that sea. It was too far to swim. We had no boats. How could we get to the new land? We were very sad. Set the prop stick and the 'Moses and the people' felt board figure aside.



# The Red Sea

**Moses**  
Lesson 3

God told me to hold out my staff. God told me to hold it out over the water. Lay down the two sides of the prop. Then, do you know what God did? He opened up the water for us! He parted the sea and made a pathway right through the water. We walked across the bottom of the sea to the other side without getting wet (Exodus 14:21-22). Move the box over to where the children can see it. As you talk, move the index card of Moses and the people across the Red Sea prop, as if they are walking across the sea. Would you like a turn to move the people across the sea on dry land? Help each child to gently move Moses and the people across the sea. Talk about how powerful God is to push all the water out of the way so the people could walk through.

Wow! Our God can do anything! He is so strong! He made the waters of the Red Sea part so Moses and the people could cross it on dry land! Isn't God amazing? If God took care of Moses and the people, do you think he will take care of us? Yes! He will.

Sing "Apart Came the Waters" from the Unit 18 Song Sheet. Hold up the sides of the Red Sea prop until you get to "apart came the waters." Then lay down the sides. Sing the song again and have a child lay down the sides of the prop at the same point in the song. Continue until each child has had a turn.

NOTE: Save the Moses figure, the 'Moses and the people' figure, the pillar prop and the 'Crossing the Red Sea' prop for the Unit 18 Lesson 4, Bible Story.

## Conclusion

Have the Moses figure ask the children the following questions:

- Who am I? (Moses)
- What did God want me to do? (lead the people out of Egypt)
- What did God put in the sky to lead us during the day? (a pillar of cloud)
- What did God put in the sky to lead us during the night? (a pillar of fire)
- What water did we come to that was too big for us to get across? (the Red Sea)
- What did God do to help us to cross it? (he parted the water)
- Did I listen to God and obey him? (Yes!)
- Did God take care of the people and me? (Yes!)

## Teacher Tips

- Use red, yellow and orange tissue paper for the pillar of fire instead of crayons.
- Explain to the children that a sea is like the ocean, where they may have played at a beach.

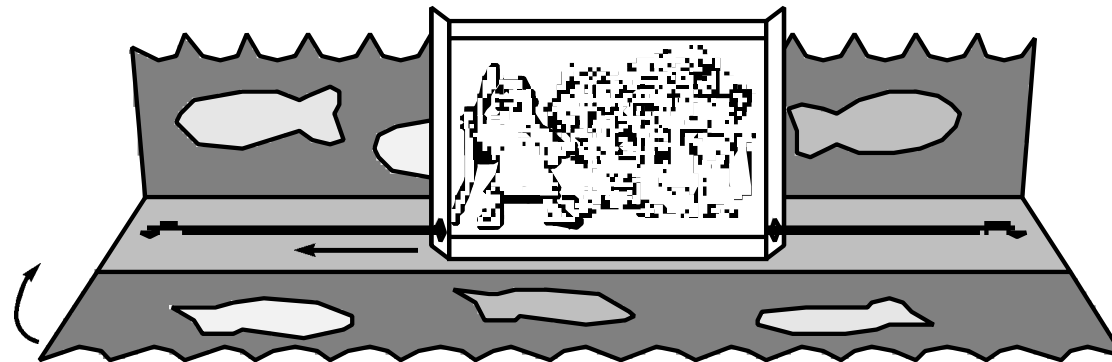

'Crossing the Red Sea' Prop

# The Red Sea

## Moses, May I?

The children will role play walking through the Red Sea and listening closely to the instructions of Moses.

### Bible Truth

We listen to God.  
(Proverbs 1:33)

### Materials

For the teacher:

- Bible
- blue or green bed sheet
- bright-colored construction paper
- scissors
- markers
- masking tape
- solid or striped pillowcase
- scarf
- cardboard wrapping paper tube
- 4 chairs

Reproducible Pages:

- Page C, 1 copy for the teacher

### Preparation

1. Cut out the fish stencil from the copy of Reproducible Page C.
2. Trace and cut out eight fish.
3. Tape the fish onto the sides of the sheet.
4. Before the children arrive make the Red Sea as follows:
  - A. Place the four chairs in a square.
  - B. Tape the corners of the sheet to each chair so that the middle of it rests flat on the floor and so the sides of the sheet are vertical. See Figure A.

### Instructions

Show the children the picture of Moses. Who is this? (Moses) Yes, in our Bible story today we are learning that he led lots of people through the Red Sea. At first Moses didn't know what to do but he listened to God and obeyed him and God spread apart the sea so that the people could walk through. Then the people had to obey Moses as he led them across the sea.

Today we are going to pretend that we are the people, and Moses is leading us through the Red Sea. Who wants to be Moses? Choose a child to be Moses. Give Moses the staff and tie the pillow case on his or her head with the scarf.

Play a game of "Moses, May I" as follows:

1. Choose a child to be Moses and have that child stand on one side of the sheet.
2. Have the other children stand in line on the other side of the sheet facing Moses.
3. Give a command to the first child in line. For example: Wendy, come through the sea on your tip-toes.
4. Wendy must say to Moses, Moses, may I?
5. Have Moses say, yes, you may.
6. Have each child come across the sea. Then start over again.

NOTE: Save the fish for the Unit 18 Lesson 4, Life Application.

### Bible Truth Activity

Open the Bible. The Bible says, "We listen to God." Let's all say that together: "We listen to God."

We listen to God when we read the Bible and obey it. Hold up the Bible. Did Moses listen to God? Yes, he did. Did the people listen to Moses? Yes, they did. We listen to God when we listen to God's leaders, our parents and teachers.

### Conclusion

Let's talk to God. Dear God, please help us to listen to you and to obey your Bible. Please help us to listen to the leaders you give us. In Jesus' name we pray. Amen.

Who are you going to tell about Bible class today? What are you going to tell them?

### Teacher Tips

- Use two tables and blue tablecloths or sheets hanging down as the walls of water.



# The Red Sea

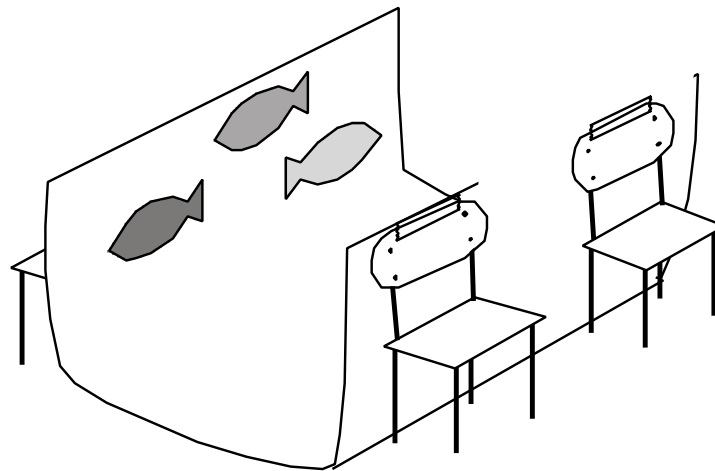

Figure A



# The Red Sea

## Crossing the Red Sea

The children will make three-dimensional crafts of Moses leading the people across the Red Sea.

### Materials

For each child:

- 1 piece of blue poster board or card stock, 9" x 12"
- 1 piece of brown construction paper or sand paper, 3" x 12"
- 1 pipe cleaner
- 1 unlined index card or poster board, 3" x 5"
- glue stick
- crayons

For the teacher:

- hole punch
- bright-colored construction paper
- ruler
- tape
- glue
- scissors
- markers

Reproducible Pages:

- Page A, 1 copy for each child
- Page D, 1 copy for the teacher

### Preparation

1. Cut out the 'Moses and the people' pictures from the copies of Reproducible Page A.
2. Cut out the fish stencil from the copy of Reproducible Page D.
3. Trace and cut out six fish for each child from construction paper.
4. Prepare the "sea and dry land" for each child as follows:
  - A. Cut a 9" x 12" piece of poster board.
  - B. Fold the poster board into 3" x 12" sections (thirds). See Figure A. NOTE: Fold the sides up over the center.
  - C. Using the scissors, cut "waves" into the longer sides of the poster board, as shown in Figure B.
  - D. Cut a 3" x 12" strip of brown construction paper for the "dry land."

5. Prepare an index card for each child, as follows:
  - A. Fold  $\frac{1}{2}$ " from both sides of the index card. NOTE: Fold the sides back from the center.
  - B. Punch a hole in each bottom corner of the card. See Figure C.
  - C. Glue a Moses and the people picture onto both sides of each card. NOTE: Leave approximately  $\frac{1}{2}$ " between the bottom of the card and the picture.
  - D. Thread a pipe cleaner through the holes in the index card. See Figure D.
6. Make two models of the craft following the instructions. IMPORTANT: Give one of the models to the Bible Story teacher to be used as a prop during that center.

### Instructions

1. Show the children the model of the craft. Who was it that led the people across the Red Sea? Yes it was Moses.
2. Help the children attach the dry land to their sea as follows:
  - A. Give each child a blue poster board and a brown construction paper strip. Help the children glue the brown strip to the middle section of the blue poster board.
  - B. Punch two holes in the ends of the brown strip, as shown in Figure E.
3. Have the children construct the finished craft as follows:
  - A. Give each child an index card with the pictures and the pipe cleaner attached and crayons. Have the children color their pictures.
  - B. Help the children to thread the pipe cleaner ends through the holes in the land, as shown in Figure F. Tape the ends of the pipe cleaner underneath the poster board.
  - C. Give each child six fish. Have the children glue their fish to the two side sections of their poster board.
  - D. Help each child to fold up the side sections of their poster board.
4. Help the children write their names on their crafts.

### Conclusion

Show the children how to gently move Moses and the people on dry land across the Red Sea.



# Craft

## The Red Sea

### Moses Lesson 3

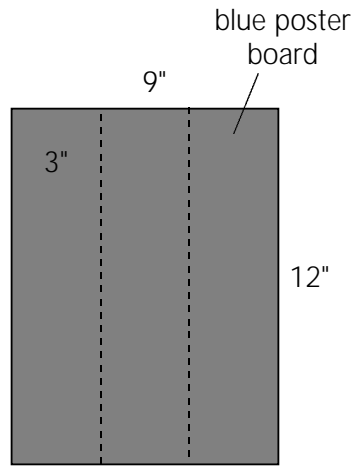

Figure A

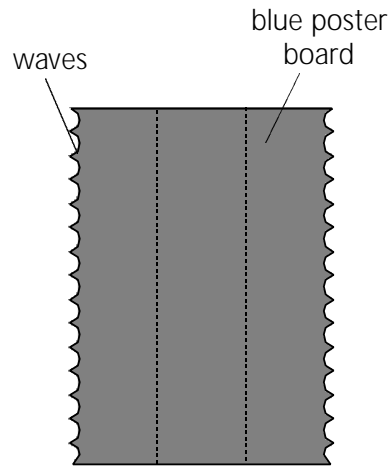

Figure B

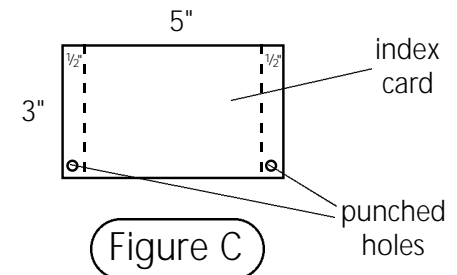

Figure C

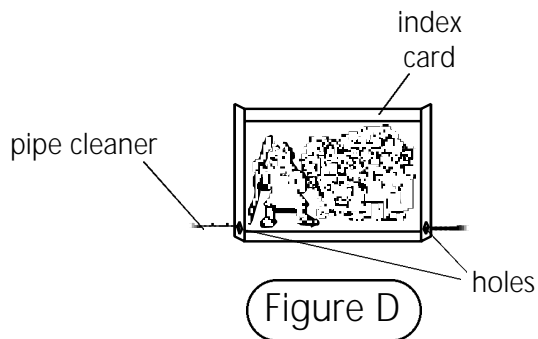

Figure D

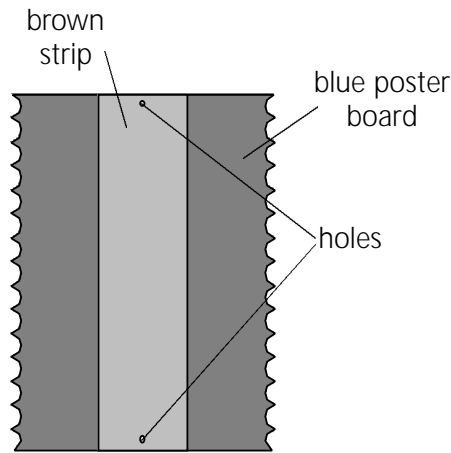

Figure E

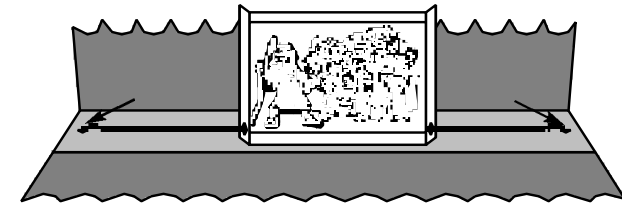
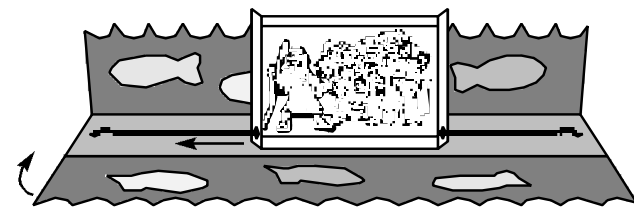

Figure F



Finished Craft







# The Red Sea

# Moses

Lesson 3

## Lesson Objectives

- The children will say “the Red Sea” when asked what sea God parted so that Moses and the people could walk through.
- The children will role play following Moses.
- The children will state that God takes care of his people.

## Bible Story Text

Exodus 13:21, 22; 14:21, 22

## Bible Truth

We listen to God.  
(Proverbs 1:33)

## Preclass Centers

As the children arrive, guide them to a pre-class center. Have no more than six children at each center.

### Materials

Use the materials previously selected for this unit’s preclass centers.

### Preparation

1. Be sure to check the condition of the materials selected for this unit’s preclass centers prior to set up. Replace any broken toys, or puzzles with missing pieces as necessary.
2. Set up the centers before the children come into the classroom.
3. Assign a teacher to each center and have the teachers stay in those centers until the singing begins.

### Instructions

Guide the play in each center reinforcing the unit theme.

## Lesson Plan

Greeting and Registration

Preclass Activity: Preclass Center

Welcome and Singing

Centers:

Life Application: All God’s Children

Bible Story: The Crossing

Craft: The Pillar

NOTE: Be sure to allow sufficient time for a snack.

### Teacher Tips

- **IMPORTANT:** Do not allow any small toys in the classroom. First check all toys for size. You can obtain a “safety cylinder” from a pediatrician. Any object that can fit into the cylinder is too small and could cause a child to choke.
- Be involved in the group play and offer guidance as needed.
- Wear comfortable clothes suitable for sitting on the floor.
- Smile! Be childlike in heart and alert in mind.

Life

Application



## All God's Children

The children will play a listening game.

### Bible Truth

We listen to God.  
(Proverbs 1:33)

### Materials

For the teacher:

- Bible
- solid or striped pillowcase and scarf
- staff or walking stick

### Preparation

1. Familiarize yourself with "Listen, Listen, Do You Hear?" from the Unit 18 Song Sheet.
2. Make a list of things for the children to do when they play "Moses Says." Some ideas are: Clap your hands; turn around in a circle; say "Amen;" pat your head; hug a friend; blink your eyes; blow a kiss, etc.

### Instructions

1. We are going to play a listening game. Who can tell me what God gave us so that we can listen? Right, God gave us ears! Can you put on your listening ears? Cup your hands beside your ears. Let's practice using our listening ears. Sing "Listen, Listen, Do You Hear?" from the Unit 18 Song Sheet.
2. Dress up as Moses by putting the pillowcase on your head and tying it in place with the scarf so it looks like a turban.
3. Tell the children that you are Moses and they are God's people. All God's children follow Moses. I will say things for you to do, but don't do them unless I first say, "Moses says."
4. Tell the children one thing for them to do. For example: Moses says clap your hands. Encourage the children when they are obedient and do what Moses said. Occasionally leave out the "Moses says" and see if anyone catches you. If not, catch yourself. Oops, I didn't say Moses says.

# The Red Sea

**Moses**  
Lesson 3

### Bible Truth Activity

Open the Bible. Remember how we listened in our song and our game today? The Bible says, We listen to God. Let's all say that together: "We listen to God." We listen to God when we read the Bible and obey it. Remember how we listened to Moses when we played the game? The Bible says we listen to God when we listen to God's leaders.

### Conclusion

Let's talk to God. Dear God, please help us to listen to you and obey your Bible. Please help us to listen to the leaders you give us. In Jesus' name we pray. Amen.

Who are you going to tell about Bible class today? What are you going to tell them?

### Teacher Tips

- When playing a game with twos and threes, there are no "winners" or "losers." They are not old enough to understand or enjoy competition.





## The Crossing

The children will learn that God took care of Moses because he obeyed him and led the people out of Egypt.

### Bible Story Text

Exodus 13:21, 22; 14:21, 22

### Materials

For the teacher:

- Bible
  - felt board
  - Moses figure and sandals from the Unit 18 Lesson 1, Bible Story
  - Pillar prop from the Craft teacher
  - 1 piece of blue poster board or card stock, 9" x 12"
  - 1 piece of brown construction paper or sand paper, 3" x 12"
  - 1 pipe cleaner
  - 1 unlined index card or poster board, 3" x 5"
  - glue stick
  - crayons or markers
  - scissors
  - 3 sheets of bright-colored construction paper
  - hole punch
  - ruler
  - tape
  - sand, pebbles, small shells
- Reproducible Pages:
- Page A, 1 copy for the teacher
  - Page D, 1 copy for the teacher
  - Page F, 1 copy for the teacher

### Preparation

1. Place two pieces of rolled tape on the back of the Moses figure.
2. Prepare the two 'Moses and the people' pictures as follows:
  - A. Cut out and color the two 'Moses and the people' pictures from the copy of Reproducible Page A.
  - B. Place two pieces of rolled tape on the back of one of the pictures to be used with the felt board. NOTE: The other picture will be used as part of the 'Crossing the Red Sea' prop.

# The Red Sea

## Moses Lesson 3

3. Make the 'Crossing the Red Sea' prop as follows:
  - A. Prepare the materials as follows:
    - 1) Cut out the fish stencil from Reproducible Page D. Trace and cut out six fish from the bright-colored construction paper.
    - 2) Cut a 9" x 12" piece of blue poster board.
    - 3) Fold the poster board into 3" x 12" sections (thirds). See Figure A. NOTE: Fold the sides up over the center.
    - 4) Using the scissors, cut waves into the longer sides of the poster board, as shown in Figure B.
    - 5) Cut a 3" x 12" strip of brown construction paper for the "dry land."
    - 6) Fold 1/2" from both sides of the index card. NOTE: Fold the sides back from the center.
    - 7) Punch a hole in each bottom corner of the card. See Figure C.
  - B. Construct the prop as follows:
    - 1) Glue the remaining 'Moses and the people' picture onto one side of the index card. NOTE: Leave approximately 1/2" between the bottom of the card and the picture.
    - 2) Thread a pipe cleaner through the holes in the index card. See Figure D.
    - 3) Glue the dry land to the middle section of the blue poster board.
    - 4) Punch two holes in the ends of the dry land, as shown in Figure E.
    - 5) Thread the pipe cleaner ends through the holes in the land, as shown in Figure F. Tape the ends of the pipe cleaner underneath the poster board.
    - 6) Glue their fish to the two side sections of their poster board.
    - 7) Fold up the side sections of the poster board.
4. Before the children arrive in class, put some sand and small pebbles on the dry land of the 'Crossing the Red Sea' prop.

## Parting of the Red Sea

Place the Moses figure on the felt board. Hello, children! Do you know who I am? My name is Moses. Have the children say hello to Moses. Open the Bible. Does anyone remember how God spoke to me? That's right, in the burning bush! Do you remember what God told me to do? He told me to go and lead his people out of Egypt to a new land (Exodus 3:1-10). Did I go? Yes, I did! I listened to God, and I obeyed him!

The Bible says that God always takes care of us when we listen to him and obey him. Do you think he took care of the people of Egypt and me? Yes, he did! The Bible says that we got all of our things ready to leave Egypt. All of the people got their children, their animals and everything they had (Exodus 12:37-39). Replace the Moses figure with the 'Moses and the people' figure on the felt board.

How would we know which way to go? How would we find the new land that God had for us? To help us, God put a special cloud in the sky to lead us during the daytime. Show the cloud on the stick. At night we could not see the cloud because it was too dark, so God put a pillar of fire in the sky (Exodus 13:21). We had light to see where to go, day or night. Turn the stick around and show the pillar of fire.

We traveled for a few days, following the cloud by day and the fire by night. Move the stick and follow it with the felt board picture. We knew that God was leading us to the new land. We were very happy!

But one day, we had a problem, and we were not so happy. We did not know what to do. We came to the edge of a big sea. It was called the Red Sea. There was no way we could go across that sea. It was too far to swim. We had no boats. How could we get to the new land? We were very sad. Set the prop stick and the 'Moses and the people' felt board figure aside.

God told me to hold out my staff. God told me to hold it out over the water. Lay down the two sides of the prop. Then, do you know what God did? He opened up the water for us! He parted the sea and made a pathway right through the water. We walked across the bottom of the sea to the other side without getting wet (Exodus 14:21-22). Move the box over to where the children can see it. As you talk, move the index card of Moses and the people across the Red Sea prop, as if they are walking across the sea. Would you like a turn to move the people across the sea on dry land? Help



# The Red Sea

## Moses Lesson 3

each child to gently move Moses and the people across the sea. Talk about how powerful God is to push all the water out of the way so the people could walk through.

Wow! Our God can do anything! He is so strong! He made the waters of the Red Sea part so Moses and the people could cross it on dry land! Isn't God amazing? If God took care of Moses and the people, do you think he will take care of us? Yes! He will.

Sing "Apart Came the Waters" from the Unit 18 Song Sheet. Hold up the sides of the Red Sea prop until you get to "apart came the waters." Then lay down the sides. Sing the song again and have a child lay down the sides of the prop at the same point in the song. Continue until each child has had a turn.

NOTE: Save the Moses figure, the 'Moses and the people' figure, the pillar prop and the 'Crossing the Red Sea' prop for the Unit 18 Lesson 4, Bible Story.

### Conclusion

Have the Moses figure ask the children the following questions:

- Who am I? (Moses)
- What did God want me to do? (lead the people out of Egypt)
- What did God put in the sky to lead us during the day? (a pillar of cloud)
- What did God put in the sky to lead us during the night? (a pillar of fire)
- What water did we come to that was too big for us to get across? (the Red Sea)
- What did God do to help us to cross it? (he parted the water)
- Did I listen to God and obey him? (Yes!)
- Did God take care of the people and me? (Yes!)

### Teacher Tips

- Use red, yellow and orange tissue paper for the pillar of fire instead of crayons.
- Explain to the children that a sea is like the ocean, where they may have played at a beach.

# Craft



## The Pillar

The children will make a craft with a cloud on one side and a pillar of fire on the other side to remind them how God takes care of his people.

### Materials

For each child:

- 1 paint stick
- 10-15 cotton balls
- 1 piece of poster board
- 1 piece of red construction paper
- glue stick

For the teacher:

- black marker
- orange and yellow tissue paper
- scissors
- glue or wood glue

Reproducible Pages:

- Page B, 1 for the teacher
- Page E, 1 copy for each child

### Preparation

1. Cut out the pillar stencil from the copy of Reproducible Page B.
2. Trace and cut out two pillar shapes for each child from poster board.
3. Trace and cut out one pillar shape for each child from red construction paper.
4. Glue each red pillar shape onto a poster board pillar shape. This will be the fire pillar. NOTE: You should have half of the poster board shapes left with nothing glued on them. They will be the cloud pillars.
5. Cut out the text strips from the copies of Reproducible Page E.
6. Cut the tissue paper into 2" pieces.
7. Make a model of the craft following the instructions.

# The Red Sea

### Instructions

1. Show the children the model of the craft. Talk about how God led the people with the cloud by day and the pillar of fire by night, so they could see the way to go.
2. Give each child a cloud pillar shape and ten cotton balls. Help the children to pull apart the cotton balls and glue them onto the pillar.
3. Give each child a fire pillar shape. Have them glue the tissue paper pieces onto the pillar.
4. Give each child a paint stick. Help them glue the two pillars together, back to back, with the paint stick in between.
5. Help the children glue the "cloud by day" text strip to the cotton ball side of the paint stick and the "fire by night" text strip to the other side.
6. Help the children write their names on their crafts.

### Conclusion

Play a game with the crafts. It's daytime now. Which pillar do we follow during the day? Now it's nighttime. Which side should it be? Which side is white and fluffy? Which side will keep us warm?

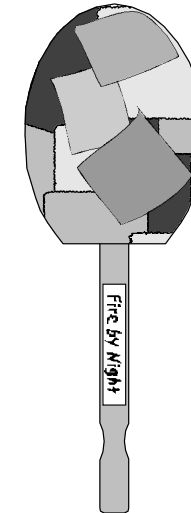

supplement

# Craft

## The Red Sea

**Moses**  
Lesson 3

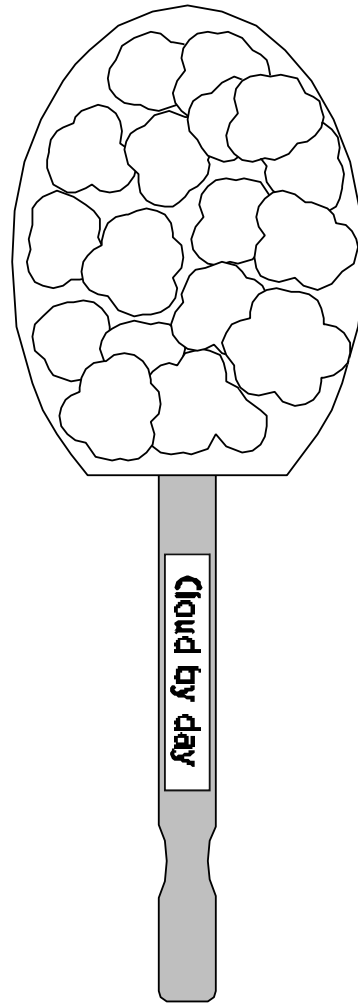

Finished Craft

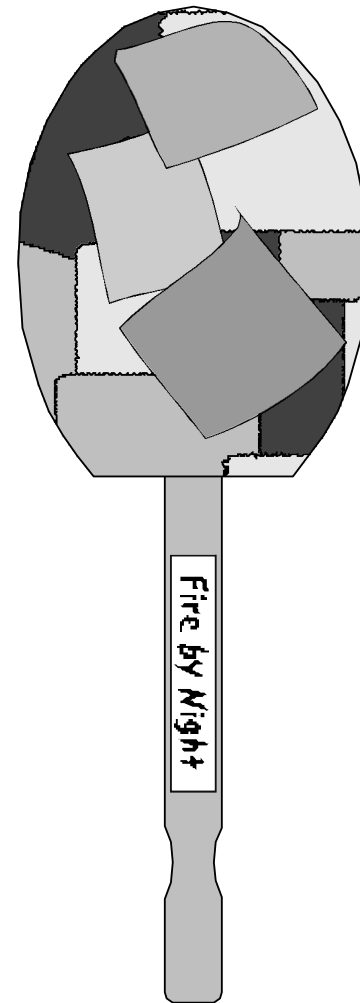

Winter 2

© 1999 by Discipleship Publications International

Moses 18:3-14



R  
e  
p  
r  
o  
d  
u  
c  
i  
b  
l  
e



'Moses and the People' pictures





R  
E  
P  
R  
O  
D  
U  
C  
E  
D  
B  
Y  
S  
E  
E  
D  
S  
O  
F  
F  
A  
I  
T  
H

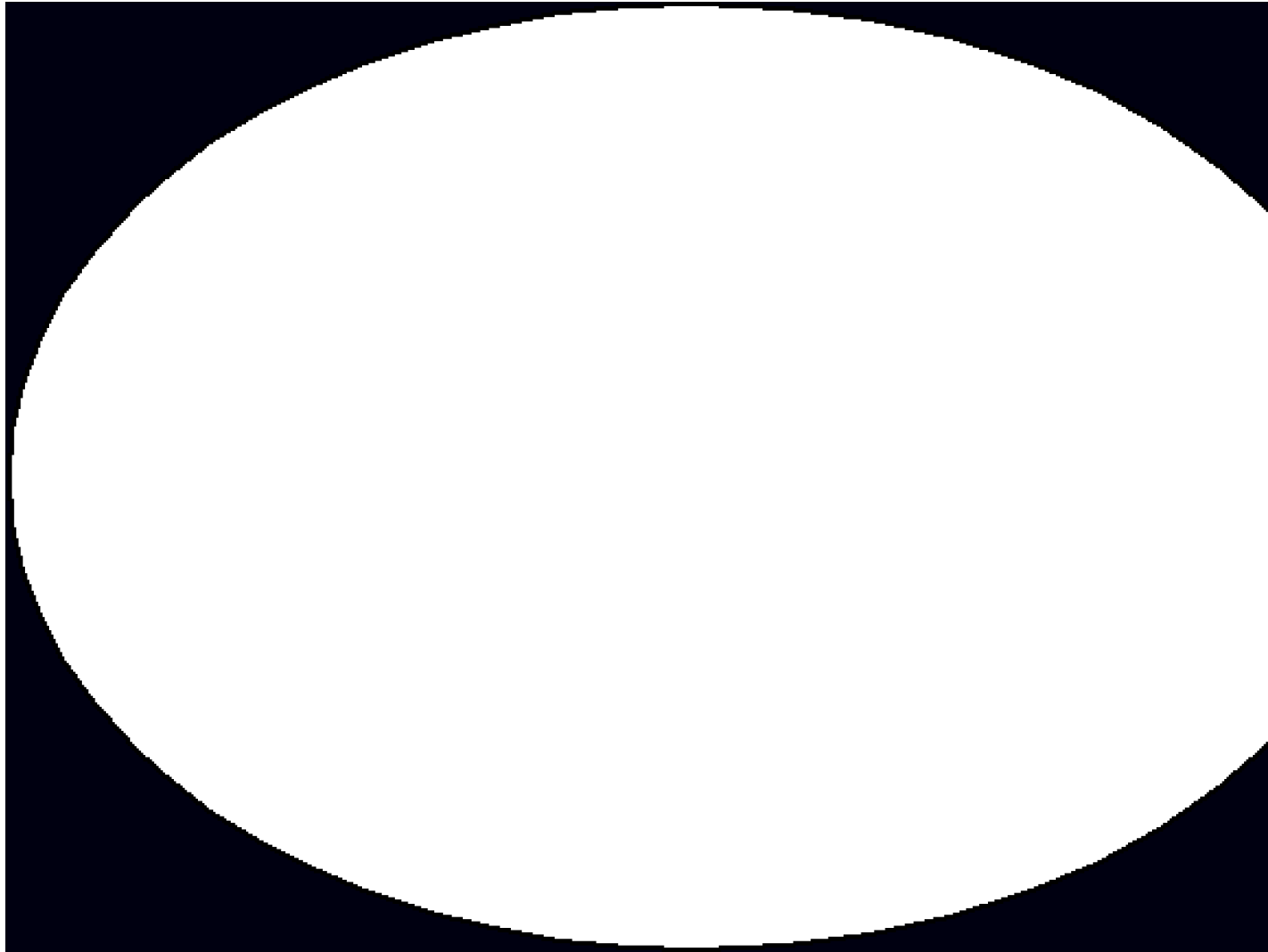

pillar stencil







R  
e  
p  
r  
o  
d  
u  
c  
e  
-  
b  
-  
e

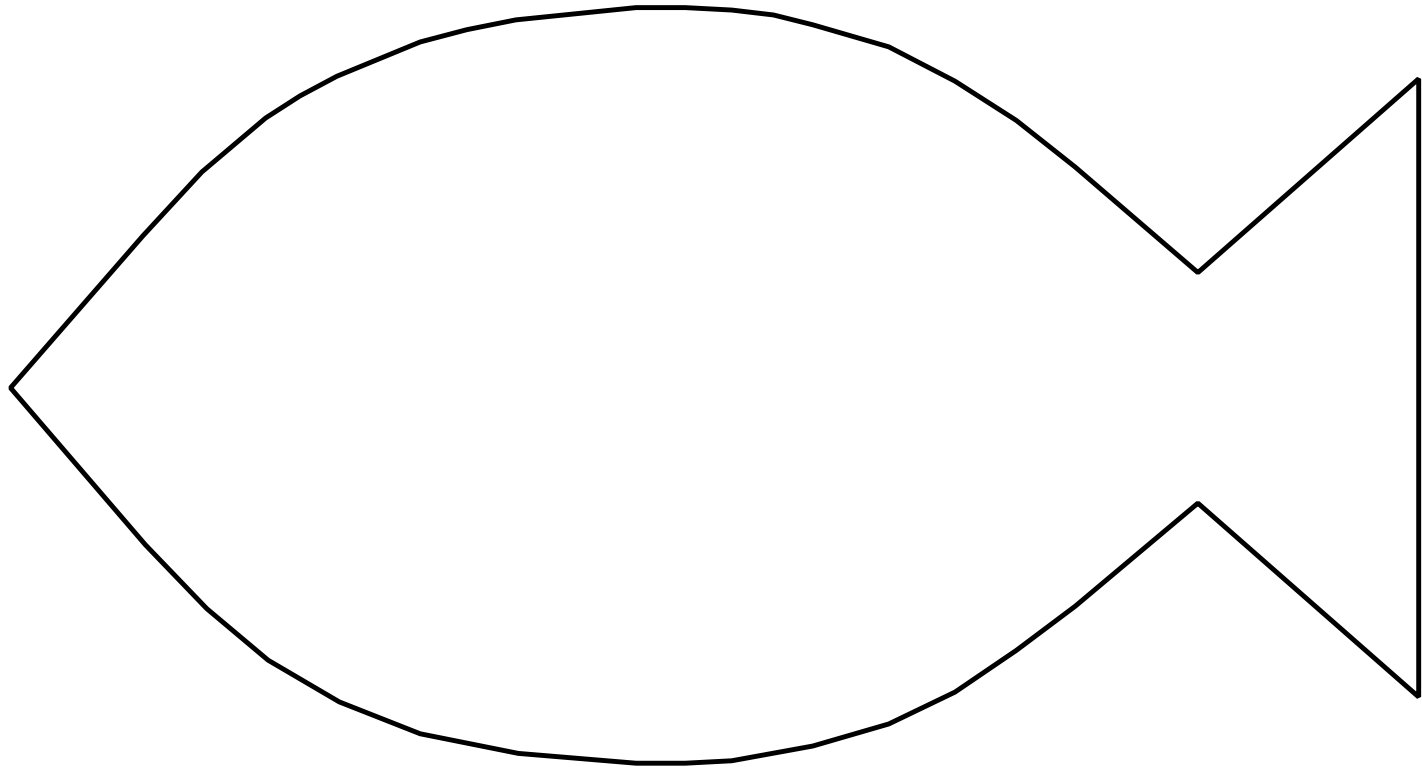

fish stencil





R  
e  
p  
r  
o  
d  
u  
c  
t  
i  
o  
n  
s  
—  
b  
—  
e

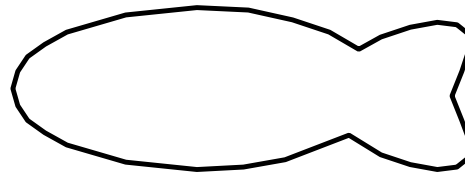

fish stencil





R  
E  
P  
R  
O  
D  
U  
C  
E  
D  
B  
Y  
E

Fire by Night

Cloud by day

text strips





Supplement/Bible Story

1 copy for the teacher

Moses  
Lesson 3

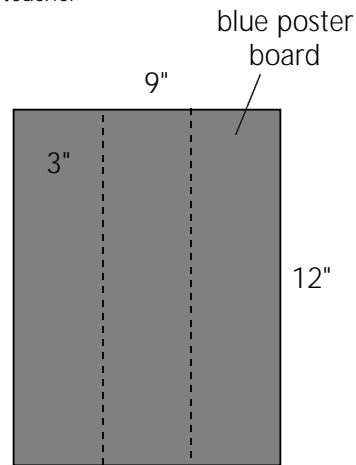

Figure A

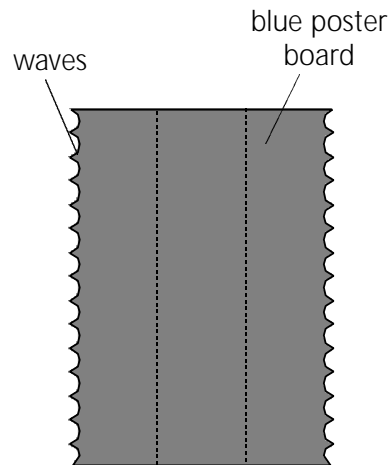

Figure B

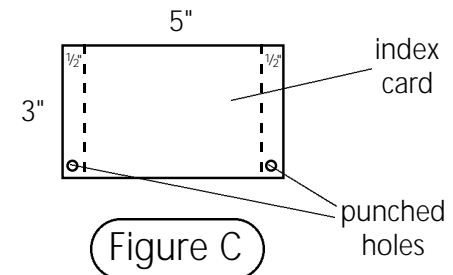

Figure C

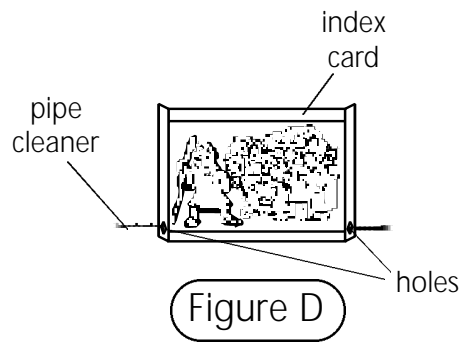

Figure D

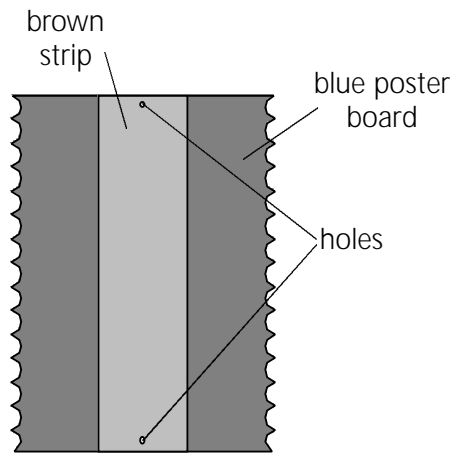

Figure E

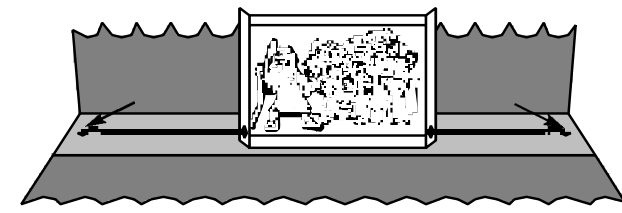
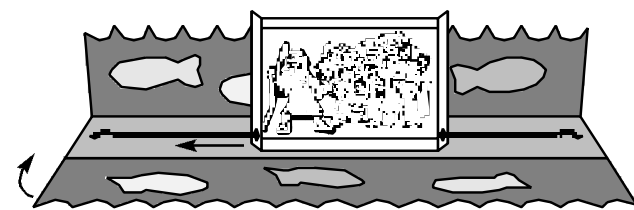

Figure F



Finished Craft

