

God's Promise

Noah
 Lesson 3

Lesson Objectives

- The children will state that God made the rainbow.
- The children will thank God for the rainbow.
- The children will name the colors; red, yellow, green and blue.

Bible Story Text

Genesis 8:1-19, 9:8-17

Bible Truth

We obey God.
 (Deuteronomy 27:10)

Lesson Plan

Greeting and Registration

Preclass Activity: Preclass Centers

Welcome and Singing

Centers:

Bible Story: Rain and Rainbows

Life Application: Color Scopes

Craft: The Ark and the Rainbow

NOTE: Be sure to allow sufficient time for a snack.



God's Promise

Preclass Centers

As the children arrive, guide them to a preclass center. Have no more than six children at each center.

Materials

Use the materials previously selected for this unit's preclass centers.

Preparation

1. Be sure to check the condition of the materials selected for this unit's preclass centers prior to set up. Replace any broken toys, or puzzles with missing pieces as necessary.
2. Set up the centers before the children come into the classroom.
3. Assign a teacher to each center and have the teachers stay in those centers until the singing begins.

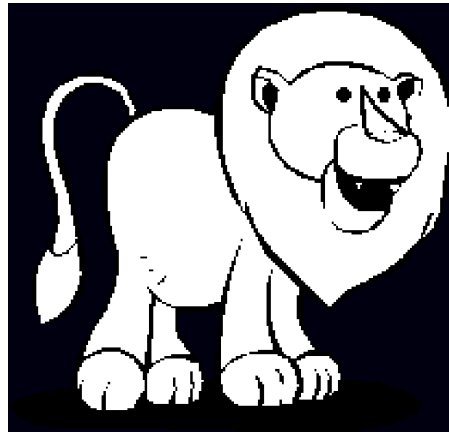

Instructions

Guide the play in each center reinforcing the unit theme.

Teacher Tips

- **IMPORTANT:** Do not allow any small toys in the classroom. First check all toys for size. You can obtain a "safety cylinder" from a pediatrician. Any object that can fit into the cylinder is too small and could cause a child to choke.
- Be involved in the group play and offer guidance as needed.
- Wear comfortable clothes suitable for sitting on the floor.
- Smile! Be childlike in heart and alert in mind.

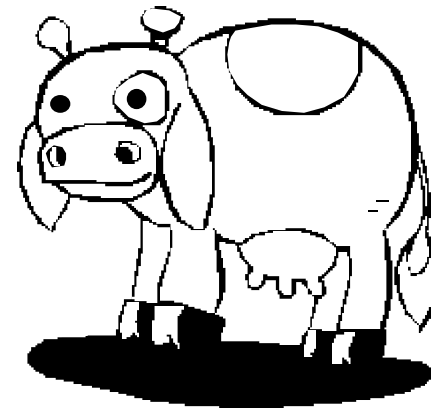

God's Promise

Rain and Rainbows

The children will learn that God made the rainbow.

Bible Story Text

Genesis 8:1-19, 9:8-17

Materials

For the teacher:

- Bible
- toy boat
- blue towel to use as the ocean
- green or brown towel as dry ground
- spray bottle with water
- spring clothespin
- 1 small branch with leaves
- glue
- markers or crayons
- scissors
- stapler
- felt board
- tape
- red, yellow, green and blue flannel or felt (optional)
- clear contact paper or laminate (optional)

Reproducible Pages:

- Page A, 1 copy for the teacher
- Page B, 1 copy for the teacher

Preparation

1. Make a dove as follows:
 - A. Cut out the dove from the copy of Reproducible Page A.
 - B. Glue the dove's body onto the clothespin so that the closed end is the dove's mouth. See Figure A.
 - C. Bend the head down slightly and the wings and tail slightly up.
2. Make a rainbow as follows:
 - A. Cut out the rainbow pattern from the copy of Reproducible Page B.
 - B. Color the rainbow red, yellow, green and blue in that order with red being the largest band and blue being the smallest.
 - C. Roll a piece of tape and place it on the back of the rainbow.

3. Before the children arrive set up the props as follows:
 - A. Place the rainbow on the felt board.
 - B. Lay the brown towel flat on the ground.
 - C. Crumple the blue towel and place it on top of the brown towel as waves.
 - D. Place the boat on top of the blue towel.

Rainbow Promises

Have the children sit around the towels, where they can see the boat. Does anyone know what this is? Yes, it is a boat. It is a special boat. We are going to pretend that this boat is the ark. Open the Bible. Who was the man in the Bible that God told to build the ark? That's right! It was Noah. Did Noah obey God and build the ark? Yes, he did!

Point to the blue towel. We are going to pretend that this is water. The ark floated on the water for a long time while it rained. Who else was on the ark with Noah and his family? The animals! God took care of Noah, his family and the animals while it rained. Let's pretend we are on a boat. Show the children how to gently rock and sway. If you put your hand out the window, you can feel the rain. Put your hands out and feel the rain. Gently spray water into the air with the spray bottle.

After 40 days, the Bible says it stopped raining! But the water was so high from all the rain, everyone had to stay on the ark. One day, a long time after it had stopped raining, Noah let a bird fly out side the window. Show the dove. This bird was a dove. Fly the dove around. The dove flew over the water looking for a tree, but the dove came back. He could not see any trees! Everything was still flooded with water! (Genesis 8:8-9). Seven days later, Noah sent the dove out again. Fly the dove around. Put the branch in the dove's mouth. This time, the dove came back to the ark and it had a green branch in its beak. The dove found a tree! (Genesis 8:10-11). The water was going down. Let the children each take a turn to fly the dove, get the branch and bring it back to the ark.

Several days later, Noah sent the dove out again. Fly the dove around. This time the dove did not come back to the ark (Genesis 8:12). Finally the water had gone down and the dove could live in the trees. He did not need to live in the ark anymore. Put the dove away.

God's Promise

Noah
Lesson 3

God told Noah that it was time to come out of the ark (Genesis 8:15-17). Remove the blue towel. All of the water had gone down, and now the ark was sitting on dry land! Noah and his family were excited! The animals were excited! They all came out of the ark (Genesis 8:18-19). They were so happy to be outside again!

Noah looked up in the sky to say thank you to God, and he saw something beautiful. Show the rainbow. God had made a rainbow and put it in the sky. He told Noah that the rainbow is a promise that it will never rain that much again (Genesis 9:8-11). Noah was so happy! He knew that God loved him and would always take care of him. Noah saw the beautiful colors in the rainbow. Point to each color, as you name it. Red, yellow, green and blue. Sing the "Rainbow Song" from the Unit 17 Song Sheet.

Has anyone ever seen a rainbow in the sky? When you see a rainbow, remember that it is God's promise to you. God loves you and will always take care of you!

NOTE: Save the dove and the rainbow for the Unit 17 Lesson 4, Bible Story.

Conclusion

Ask the following questions to review the story:

- What bird did Noah send out of the ark? (a dove)
- What did the dove bring back in his mouth? (a branch or leaves)
- What did God put into the sky as a promise to Noah? (a rainbow)
- Did Noah obey God? (yes)

Teacher Tips

- If you use real leaves, be sure that they are not poisonous.
- Cut the copy of the rainbow into strips and use them as stencils to trace and cut out felt pieces to make a felt rainbow.
- Laminate the paper rainbow with clear contact paper.

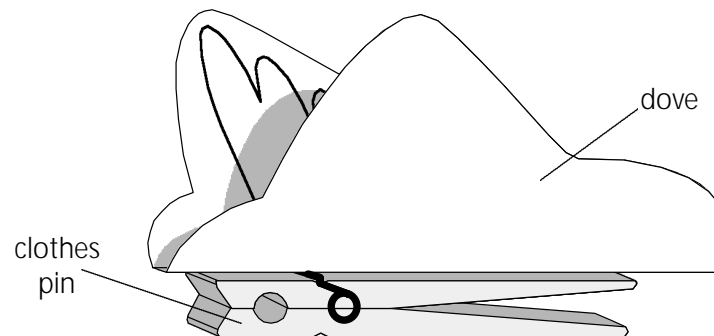

Figure A



God's Promise

Color Scopes

The children will be reminded of the rainbow that God created.

Bible Truth

We obey God.
(Deuteronomy 27:10)

Materials

For the teacher:

- Bible
- 4 toilet paper tubes
- plastic wrap or clear cellophane
- rubber bands
- construction paper, gift wrap or colored contact paper
- scissors
- glue
- stickers
- markers

Reproducible Pages:

- Page B, 1 copy for the teacher

Preparation

1. Prepare the toilet paper tubes as follows:
 - A. Cover each toilet paper tube with a piece of construction paper.
 - B. Decorate the tube with markers and stickers.
 - C. Cut a 4" x 4" piece of plastic wrap for each tube.
 - D. Place a piece of plastic wrap over the end of each tube and secure it in place with a rubber band. See Figure A.
 - E. Color the plastic wrap on the end of each tube with a marker. Color one red, one yellow, one green and one blue. Only color the circular portion covering the opening of the tube.
2. Cut out the rainbow from the copy of Reproducible Page B.
3. Color the bands of the rainbow from the outside in, red, yellow, green and blue.
4. Glue the rainbow onto a piece of construction paper.

Instructions

1. Hold up the rainbow. Who can tell me what this is? Right, it's a rainbow! Who makes rainbows? God does! Let's look at the different colors God put in the rainbows. Point to each color as you name it. Let each child point to and name the colors. Offer help as needed.
2. Sing the "Rainbow Song" from the Unit 17 Song Sheet, pointing to the different colors as you sing. Who likes rainbows? Who likes colors? Who knows who made the colors? That's right! God did!
3. Today we are going to look at the colors that God made. Show the children the red tube. This is a Color Scope. Whenever we look through it, we will see everything in that color. What color is this? It is red! Whenever we look through the red Color Scope, everything we look at will be red! Pass the tube around and let each of the children have a turn looking at something with the red Color Scope.
4. Repeat this with each of the tubes.

NOTE: Save the Color Scopes and the rainbow for the Unit 17 Lesson 4, Life Application.

Bible Truth Activity

When God told Noah to build the ark, did Noah obey God? Yes, he did! Open the Bible. The Bible says we should obey God. When Noah obeyed God and took the animals inside the ark while it rained, they were all safe. Then after they came out of the ark, what did God put in the sky? Hold up the rainbow picture. God put the rainbow in the sky as a promise to Noah. God took care of Noah because Noah obeyed him. Jonathan, will you obey God? Ask each child. Let's all say our Bible Truth together: "We obey God." Hold up the Bible. We obey God when we obey the Bible.



God's Promise

Conclusion

Let's talk to God. Dear God, please help us to love and obey you and please help us to obey your Bible. In Jesus' name we pray. Amen.

Who are you going to tell about Bible class today? What are you going to tell them?

If time allows, give each child a Color Scope and sing the "Rainbow Song" from the Unit 17 Song Sheet as the children play.

Teacher Tips

- Use rainbow and Noah stickers to decorate the tubes.
- Use colored cellophane or plastic wrap instead of coloring the clear plastic wrap.
- Cut out a few simple shapes from white construction paper or poster board for the children to look at with the color maker.
- As the children get comfortable with the song, have those who would like to hold the rainbow picture and point to each color as they sing.
- Keep the rainbow picture and add the "Rainbow Song" to your class group singing time.

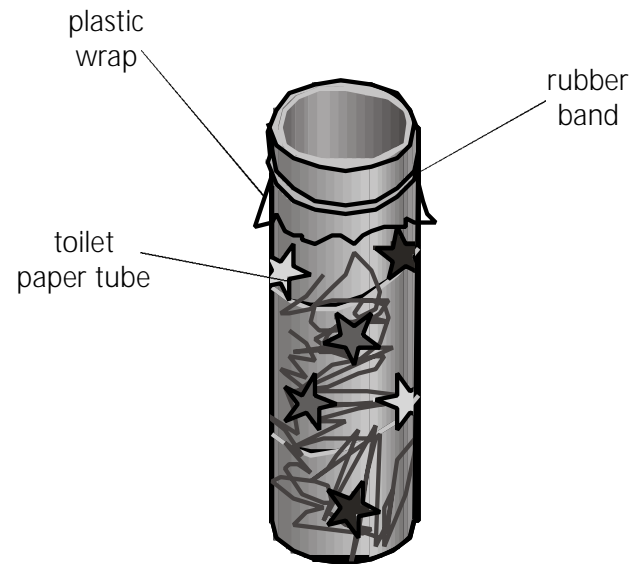

Figure A

Craft

God's Promise The Ark and the Rainbow

This craft will remind the children that after the rain, God made a rainbow.

Materials

For each child:

- 1 piece of dark blue construction paper
- 1 piece of yellow construction paper
- 1 pipe cleaner
- crayons
- 1 cotton swab
- small paper cup

For the teacher:

- tape
- white glue
- hole punch
- scissors
- utility knife
- black marker

Reproducible Pages:

- Page C, 1 copy for the teacher

Preparation

1. Cut each pipe cleaner in half.
2. Prepare an ark booklet for each child as follows:
 - A. Cut out the ark stencil from the copy of Reproducible Page C.
 - B. Trace the ark stencil onto the center of the blue construction paper.
 - C. Cut out the ark using a utility knife.
 - D. Print "First the rain" on the top of the blue construction paper.
 - E. Print "then the rainbow!" on the bottom of the yellow construction paper.
 - F. Place the blue construction paper on top of the yellow construction paper. With a black marker, trace the ark onto the yellow paper.
 - G. Punch two holes at the top of the papers.
 - H. Thread one half pipe cleaner through each hole and twist it together, forming a booklet. See Figure A.
3. Make a model of the craft following the instructions.

Noah
Lesson 3

Instructions

1. Show the children the model of the craft. Read the words to them and ask them what they think the picture is.
2. Give each child a booklet.
3. Have the children color in the ark on the yellow paper and then draw a rainbow over the ark with crayons (red, yellow, green and blue).
4. Give each child a cotton swab and a paper cup with glue in it. Have each child dip the cotton swab into the cup, and then touch it lightly to the blue paper making "raindrops."
5. Write the children's names on their papers.

Conclusion

Have the children close their crafts. Read together "First the rain." Have the children open their crafts. "Then the rainbow!"

Teacher Tips

- Place a few sheets of construction paper together and cut out the stencil over cardboard to cut a few arks at the same time.

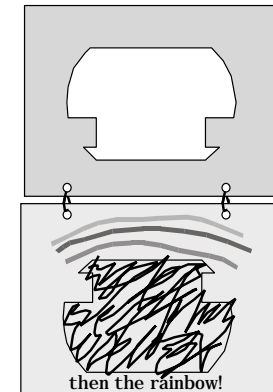
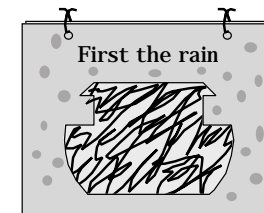

ttfarrcc

God's Promise

Noah
Lesson 3

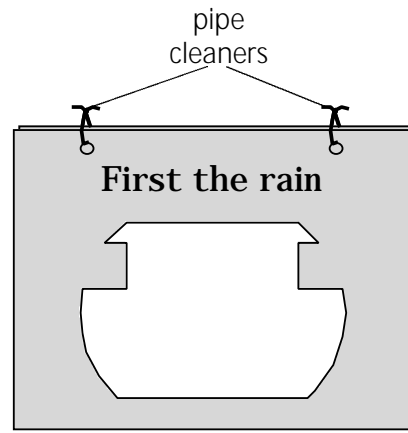
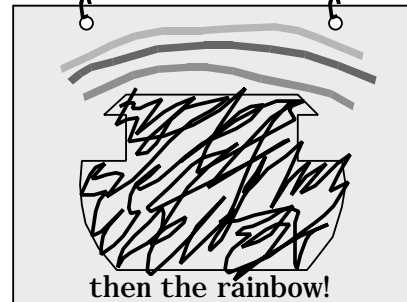
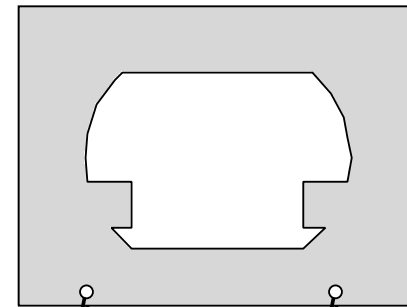
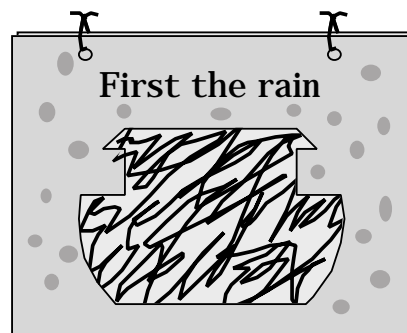

Figure A



Finished Craft





God's Promise

Noah

Lesson 3

Lesson Objectives

- The children will state that God made the rainbow.
- The children will thank God for the rainbow.
- The children will name the colors; red, yellow, green and blue.

Bible Story Text

Genesis 8:1-19, 9:8-17

Bible Truth

We obey God.
(Deuteronomy 27:10)

Preclass Centers

As the children arrive, guide them to a pre-class center. Have no more than six children at each center.

Materials

Use the materials previously selected for this unit's preclass centers.

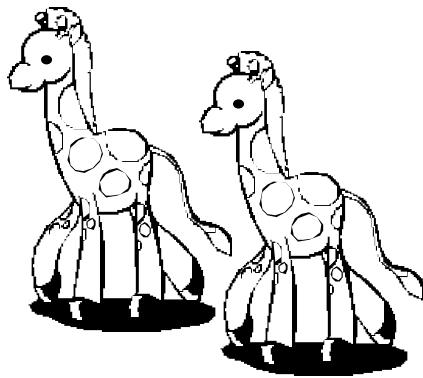

Preparation

1. Be sure to check the condition of the materials selected for this unit's preclass centers prior to set up. Replace any broken toys, or puzzles with missing pieces as necessary.
2. Set up the centers before the children come into the classroom.
3. Assign a teacher to each center and have the teachers stay in those centers until the singing begins.

Instructions

Guide the play in each center reinforcing the unit theme.

Lesson Plan

Greeting and Registration

Preclass Activity: Preclass Centers

Welcome and Singing

Centers:

Life Application: Funny Brown Bunny

Bible Story: Rain and Rainbows

Craft: Rainbow Hat

NOTE: Be sure to allow sufficient time for a snack.

Teacher Tips

- **IMPORTANT:** Do not allow any small toys in the classroom. First check all toys for size. You can obtain a "safety cylinder" from a pediatrician. Any object that can fit into the cylinder is too small and could cause a child to choke.
- Be involved in the group play and offer guidance as needed.
- Wear comfortable clothes suitable for sitting on the floor.
- Smile! Be childlike in heart and alert in mind.

Life

Application



Funny Brown Bunny

The children will learn that God made beautiful and special colors.

Bible Truth

We obey God.
(Deuteronomy 27:10)

Materials

For the teacher:

- Bible
- 1 manila file folder
- pen or pencil
- scissors
- utility knife
- glue stick
- construction paper, 1 sheet of brown, red, yellow, green and blue

Reproducible Pages:

- Page B, 1 copy for the teacher
- Page D, 1 copy for the teacher

Preparation

1. Cut out and color (red, yellow, green and blue from the outside in) the rainbow from the copy of Reproducible Page B.
2. Cut out the bunny stencil from the copy of Reproducible Page D. Trace and cut out the bunny from the center of the manila folder with a utility knife.
3. Glue a sheet of brown construction paper on the inside of the folder opposite the bunny cutout. Place the construction paper into the folder.

Instructions

Take out the bunny prop. Take out all of the colored paper so that the bunny is brown. Funny Bunny hopped along the road. Hop, hop, hop! Funny Bunny was a beautiful brown bunny just like his mommy bunny. As he hopped, he sang a funny little song. Sing "Funny Brown Bunny" from the Unit 17 Song Sheet.

One day Funny Bunny saw a red bird. He thought the red bird was the prettiest color he had ever seen. "I want to be red like the bird," he said. So he rolled in some red strawberries. Slip the red paper inside the folder. What color is Funny Bunny now? He is red! As he hopped down the road, he sang... Sing "Funny Brown Bunny

God's Promise

from the Unit 17 Song Sheet substituting "red" for brown.

Later that day he saw a yellow duck. He thought yellow was the prettiest color he had ever seen. "I want to be yellow like the duck," he said. So he found some yellow feathers and stuck them all over his bunny fur. Slip the yellow paper inside the folder. What color is Funny Bunny now? He is yellow! As he hopped down the road, he sang... Sing "Funny Brown Bunny from the Unit 17 Song Sheet substituting "yellow" for brown.

Later that day, he saw some green grass. "I want to be green like the grass." He rolled around in some newly mowed green grass. Slip the green paper inside the folder. What color is Funny Bunny now? He is green! As he hopped down the road, he sang... Sing "Funny Brown Bunny from the Unit 17 Song Sheet substituting "green" for brown.

Later that day he saw the blue sky. It was the bluest blue he had ever seen. "I want to be blue like the blue sky," he said. So he rolled in some blueberries. Slip the blue paper inside the folder. What color is Funny Bunny now? He is blue! As he hopped down the road, he sang... Sing "Funny Brown Bunny from the Unit 17 Song Sheet substituting "blue" for brown.

Just then the funny bunny's mommy called him inside for dinner. "Funny Bunny," said his mommy, "you are blue! Where is my beautiful brown bunny?" "Blue sky is beautiful," said Funny Bunny. "Yes, blue is a beautiful color," said his mommy, "but God didn't make you blue." His mommy helped him wipe off the blue. Take out the sheets so bunny is brown again. "God made you my beautiful brown little Funny Bunny, and I love you very much." "I love you, too, Mommy," NOTE: Save the funny bunny for the Unit 17 Lesson 4, Life Application.

Bible Truth Activity

When Funny Bunny's mommy told him not to roll in any more berries, he obeyed. When God told Noah to build the ark, did Noah obey God? Yes, he did! Open the Bible. The Bible says we should obey God. Let's all say our Bible Truth together: "We obey God." Hold up the Bible. We obey God when we obey the Bible.

Conclusion

Pray with the children asking God to help them be obedient. Encourage them to bring their friends to class.

Rain and Rainbows

The children will learn that God made the rainbow.

Bible Story Text

Genesis 8:1-19, 9:8-17

Materials

For the teacher:

- Bible
- toy boat
- blue towel to use as the ocean
- green or brown towel as dry ground
- spray bottle with water
- spring clothespin
- 1 small branch with leaves
- glue
- markers or crayons
- scissors
- stapler
- felt board
- tape
- red, yellow, green and blue flannel or felt (optional)
- clear contact paper or laminate (optional)

Reproducible Pages:

- Page A, 1 copy for the teacher
- Page B, 1 copy for the teacher

Preparation

1. Make a dove as follows:
 - A. Cut out the dove from the copy of Reproducible Page A.
 - B. Glue the dove's body onto the clothespin so that the closed end is the dove's mouth. See Figure A.
 - C. Bend the head down slightly and the wings and tail slightly up.
2. Make a rainbow as follows:
 - A. Cut out the rainbow pattern from the copy of Reproducible Page B.
 - B. Color the rainbow red, yellow, green and blue in that order with red being the largest band and blue being the smallest.
 - C. Roll a piece of tape and place it on the back of the rainbow.

God's Promise

Noah Lesson 3

3. Before the children arrive set up the props as follows:
 - A. Place the rainbow on the felt board.
 - B. Lay the brown towel flat on the ground.
 - C. Crumple the blue towel and place it on top of the brown towel as waves.
 - D. Place the boat on top of the blue towel.

Rainbow Promises

Have the children sit around the towels, where they can see the boat. Does anyone know what this is? Yes, it is a boat. It is a special boat. We are going to pretend that this boat is the ark. Open the Bible. Who was the man in the Bible that God told to build the ark? That's right! It was Noah. Did Noah obey God and build the ark? Yes, he did!

Point to the blue towel. We are going to pretend that this is water. The ark floated on the water for a long time while it rained. Who else was on the ark with Noah and his family? The animals! God took care of Noah, his family and the animals while it rained. Let's pretend we are on a boat. Show the children how to gently rock and sway. If you put your hand out the window, you can feel the rain. Put your hands out and feel the rain. Gently spray water into the air with the spray bottle.

After 40 days, the Bible says it stopped raining! But the water was so high from all the rain, everyone had to stay on the ark. One day, a long time after it had stopped raining, Noah let a bird fly out side the window. Show the dove. This bird was a dove. Fly the dove around. The dove flew over the water looking for a tree, but the dove came back. He could not see any trees! Everything was still flooded with water! (Genesis 8:8-9). Seven days later, Noah sent the dove out again. Fly the dove around. Put the branch in the dove's mouth. This time, the dove came back to the ark and it had a green branch in its beak. The dove found a tree! (Genesis 8:10-11). The water was going down. Let the children each take a turn to fly the dove, get the branch and bring it back to the ark.

Several days later, Noah sent the dove out again. Fly the dove around. This time the dove did not come back to the ark (Genesis 8:12). Finally the water had gone down and the dove could live in the trees. He did not need to live in the ark anymore. Put the dove away.

God's Promise

Noah
Lesson 3

God told Noah that it was time to come out of the ark (Genesis 8:15-17). Remove the blue towel. All of the water had gone down, and now the ark was sitting on dry land! Noah and his family were excited! The animals were excited! They all came out of the ark (Genesis 8:18-19). They were so happy to be outside again!

Noah looked up in the sky to say thank you to God, and he saw something beautiful. Show the rainbow. God had made a rainbow and put it in the sky. He told Noah that the rainbow is a promise that it will never rain that much again (Genesis 9:8-11). Noah was so happy! He knew that God loved him and would always take care of him. Noah saw the beautiful colors in the rainbow. Point to each color, as you name it. Red, yellow, green and blue. Sing the "Rainbow Song" from the Unit 17 Song Sheet.

Has anyone ever seen a rainbow in the sky? When you see a rainbow, remember that it is God's promise to you. God loves you and will always take care of you!

NOTE: Save the dove and the rainbow for the Unit 17 Lesson 4, Bible Story.

Conclusion

Ask the following questions to review the story:

- What bird did Noah send out of the ark? (a dove)
- What did the dove bring back in his mouth? (a branch or leaves)
- What did God put into the sky as a promise to Noah? (a rainbow)
- Did Noah obey God? (yes)

Teacher Tips

- If you use real leaves, be sure that they are not poisonous.
- Cut the copy of the rainbow into strips and use them as stencils to trace and cut out felt pieces to make a felt rainbow.
- Laminate the paper rainbow with clear contact paper.

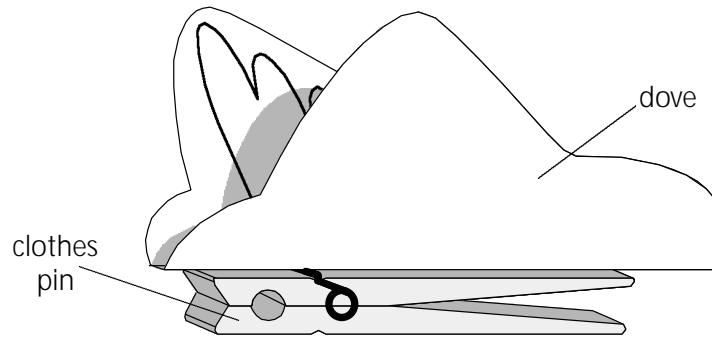

Figure A



Craft



Rainbow Hat

The children will make a hat to help them remember God's rainbow promise.

Materials

For each child:

- 1 large paper plate
- glue stick

For the teacher:

- red, yellow, green and blue construction paper
- cardboard
- utility knife
- scissors
- marker

Reproducible Pages:

- Page E, 1 copy for each child

Preparation

1. Cut out the large circle stencil from one of the copies of Reproducible Page E.
2. Prepare a stencil from cardboard for each circle size.
3. Trace and cut out 1 circle for every 2 children as follows:
 - A. The #1 circle on red construction paper.
 - B. The #2 circle on yellow construction paper.
 - C. The #3 circle on green construction paper.
 - D. The #4 circle on blue construction paper.
 - E. Cut each circle in half.
4. Cut the center circle of each paper plate about $\frac{3}{4}$ of the way around leaving the remaining $\frac{1}{4}$ still attached. See Figure A.
5. Fold the center circle along the dotted line as shown in Figure B.
6. Cut out the clouds from each copy of Reproducible Page E.
7. Make a model of the craft following the instructions.

God's Promise

Instructions

1. Show the children the model craft. Who can tell me what this is? A rainbow! Who made the rainbow? God did! Can anyone name the colors in this rainbow? Red, yellow, green and blue.
2. Give each child a pre-cut paper plate. Turn the plates face down on the table.
3. Give each child a red half circle and help them glue it onto the paper plate, aligning the bottom of the half circle with the fold line. See Figure C.
4. Give each child a yellow half circle and help them to glue it on the red circle, aligning the bottom of the circles together. See figure D.
5. Repeat Step 4 with the green and then the blue half circles.
6. Help the children to gently fold up the cutout section on the plates to form a hat.
7. Give each child 2 clouds to glue above the half circles as shown in Figure E.

Conclusion

Let the children try on their hats. Sing the "Rainbow Song" from the Unit 17 Song Sheet. This is to remind you of God's rainbow promise! It will help you to remember that God loves us and takes care of us.

Teacher Tips

- Not all children will want to wear hats. It is fine if they do not want to wear them.
- For a younger class, construct the rainbows before class. Glue the half circles onto each other in the order stated in steps 4 and 5. Then have the children glue the completed rainbow onto the hat.

Craft

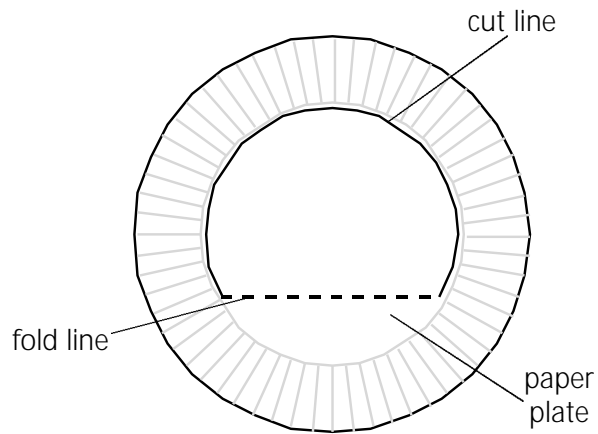

Figure A

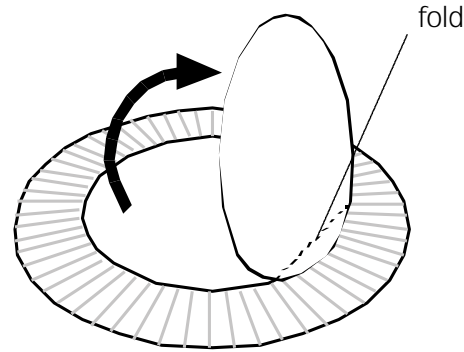

Figure B

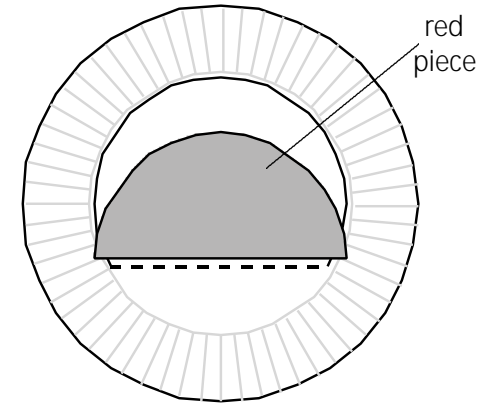

Figure C

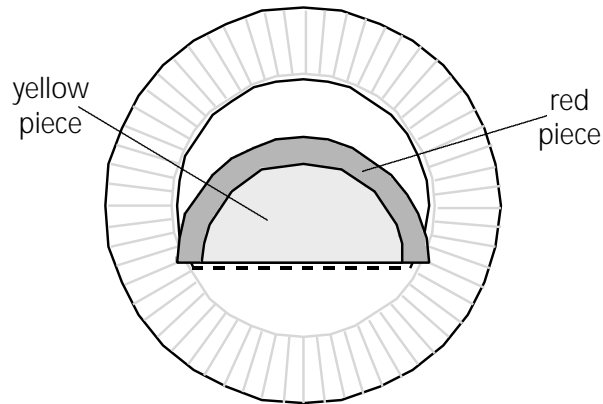

Figure D

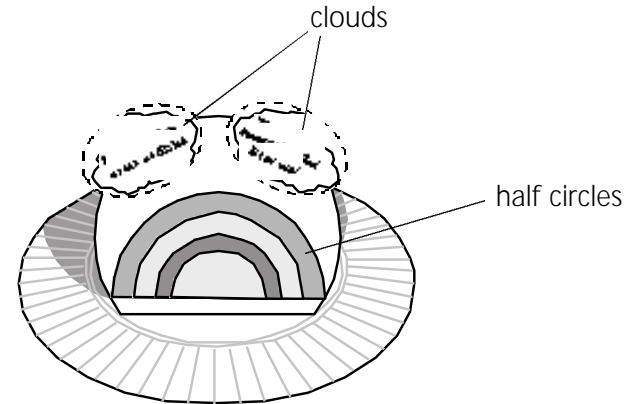
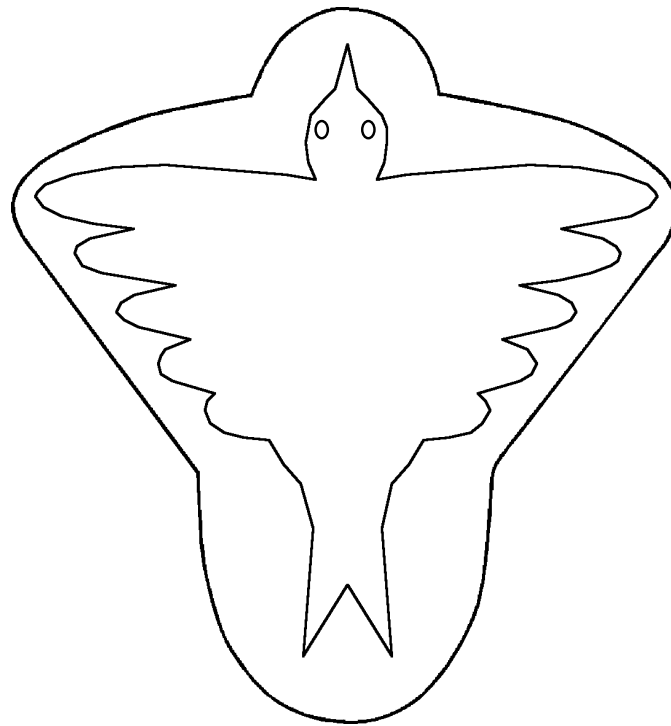

Figure E





R
e
p
r
o
d
u
c
e
d
b
y
e



dove



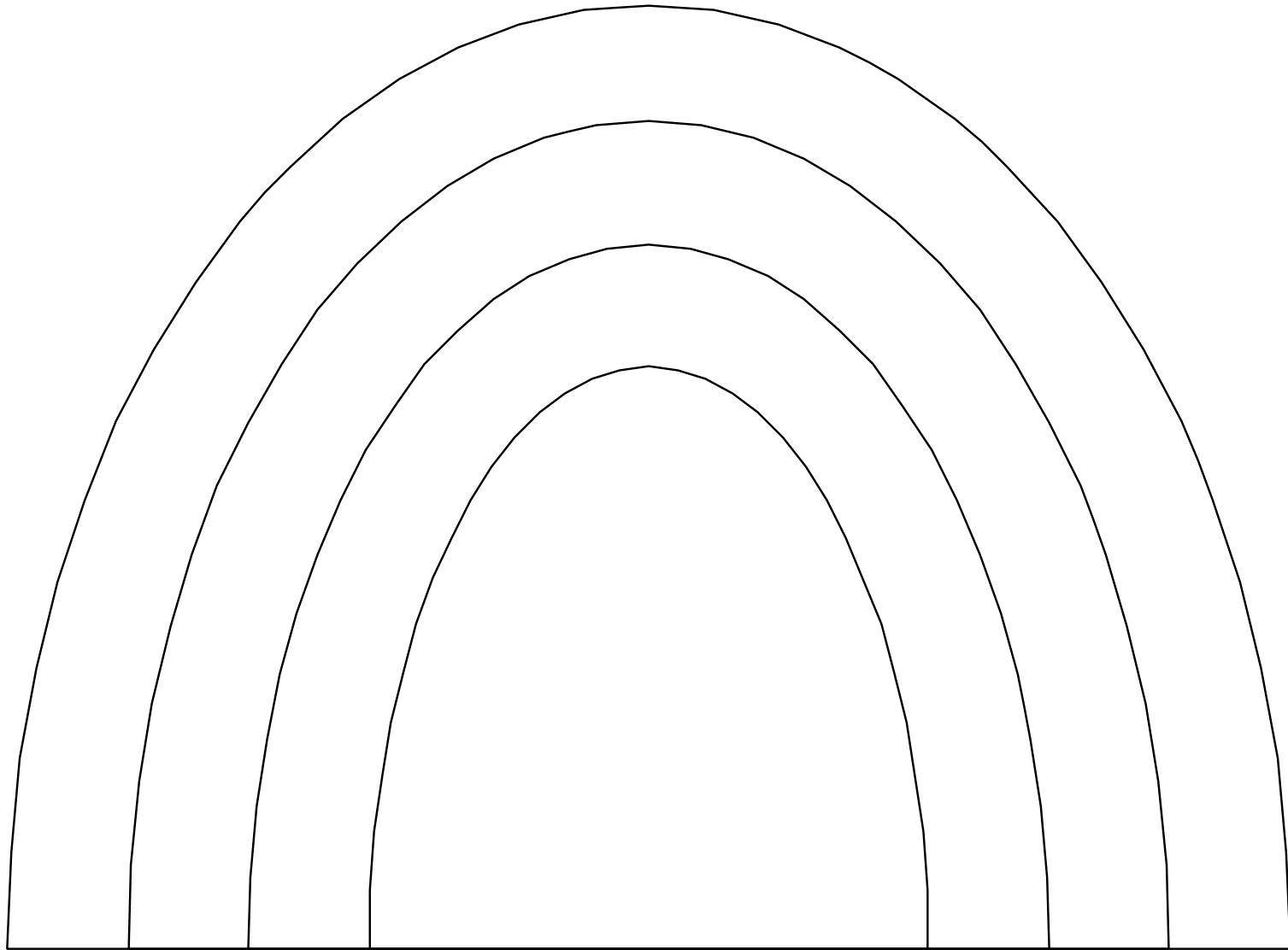

rainbow



R
e
p
r
o
d
u
c
e
d
b
y
e

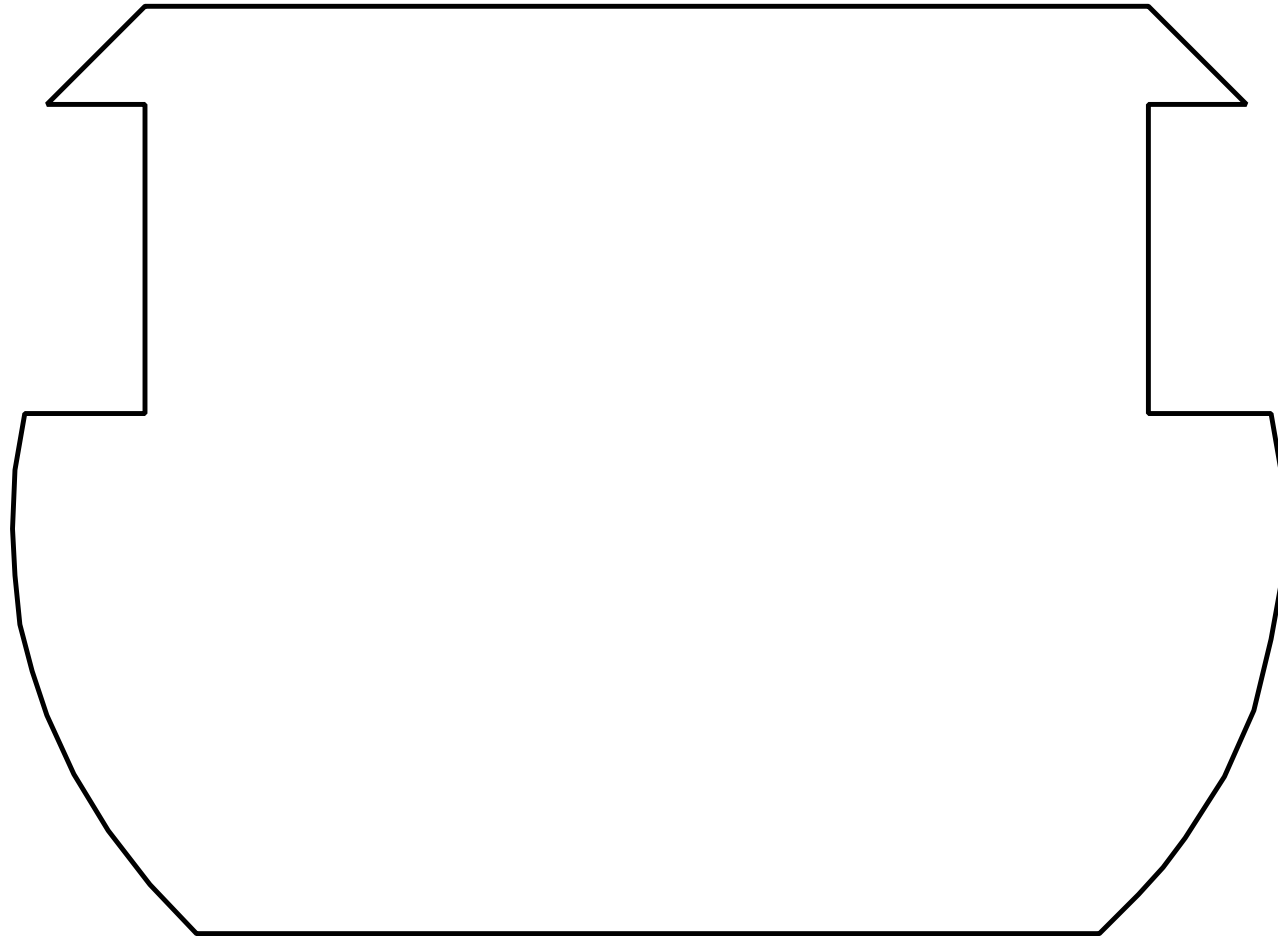

ark stencil





R
E
P
R
O
D
U
C
E
D
B
Y
D
I
S
C
I
P
L
E
S
H
I
P
P
U
B
L
I
S
H
I
P
S
I
N
T
E
R
N
A
T
I
O
N
A
L

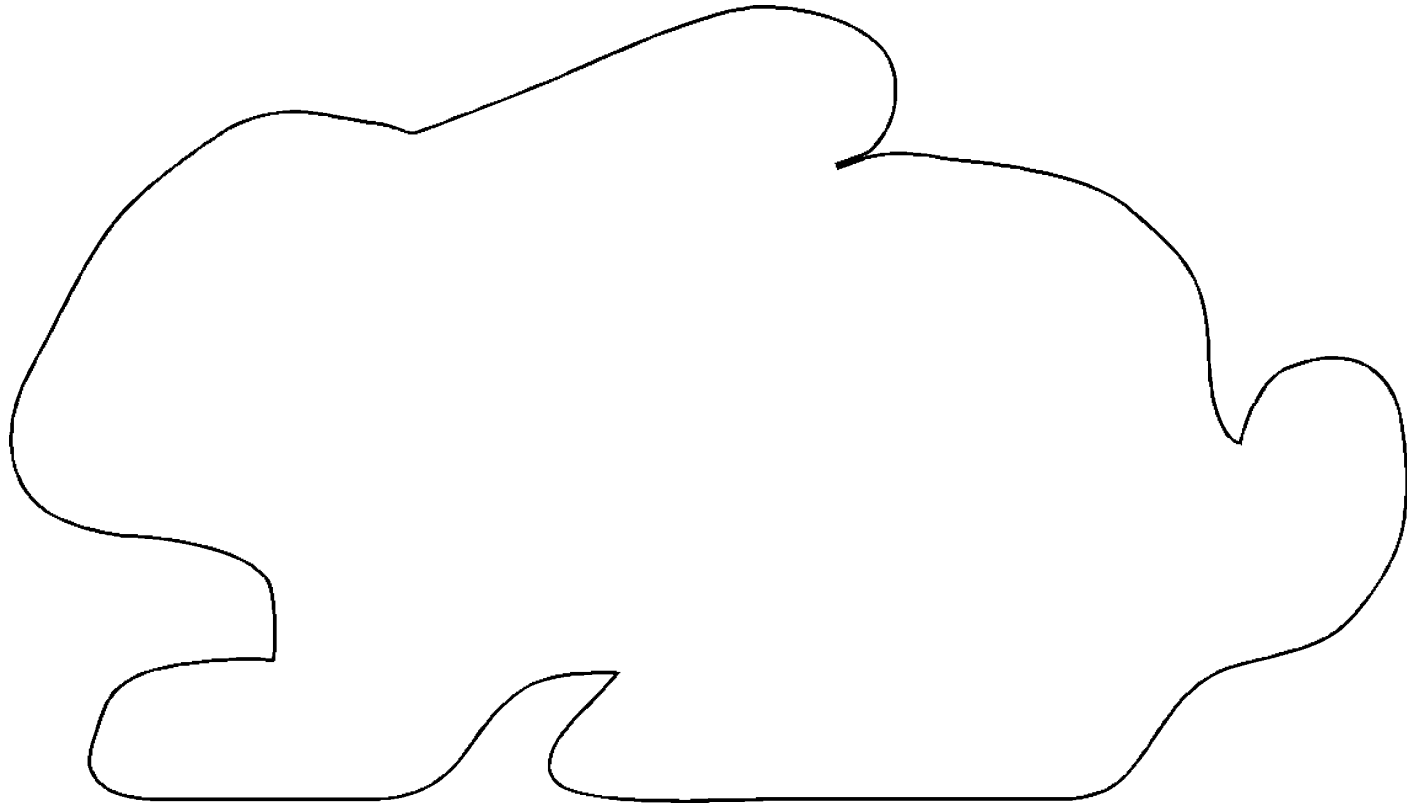

bunny stencil





R
E
P
R
O
D
U
C
E
D
I
N
G
S

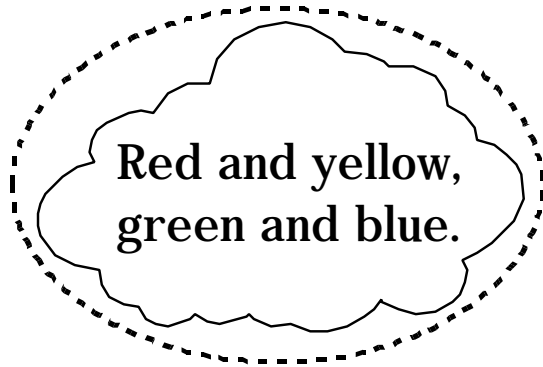

clouds

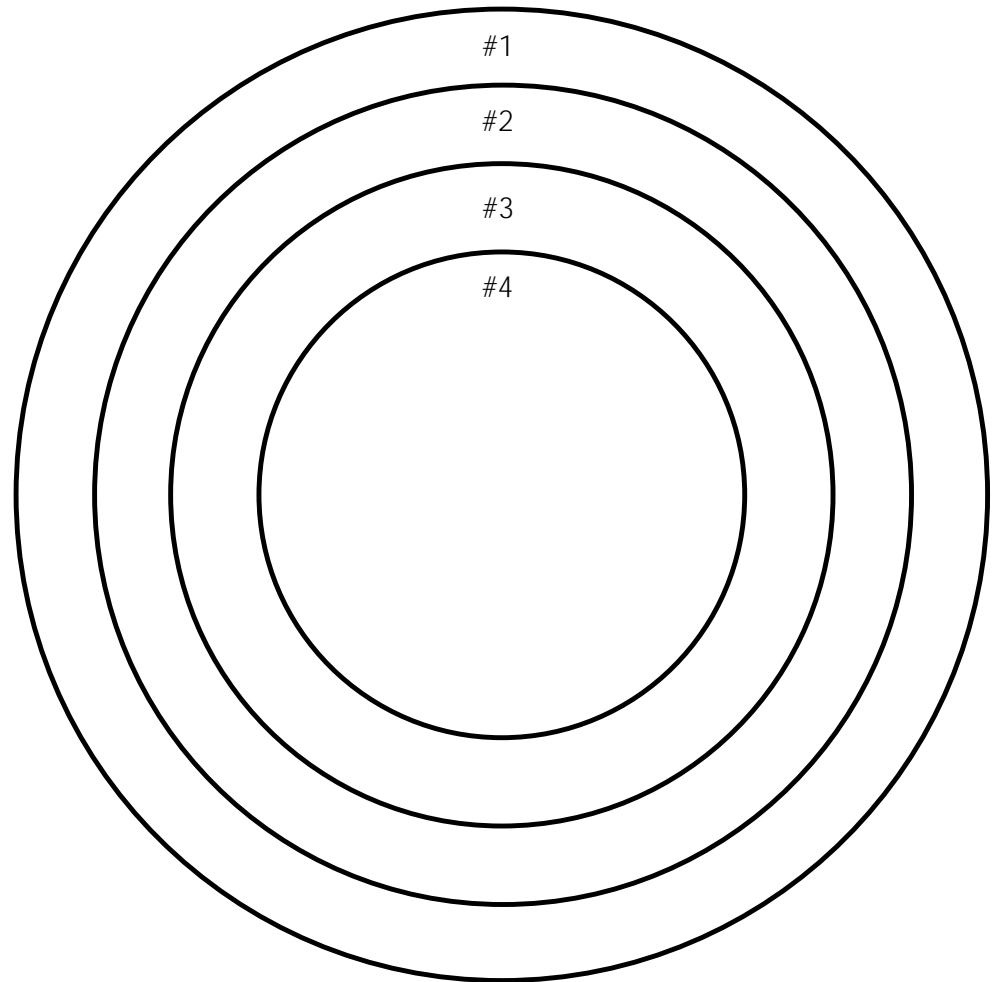
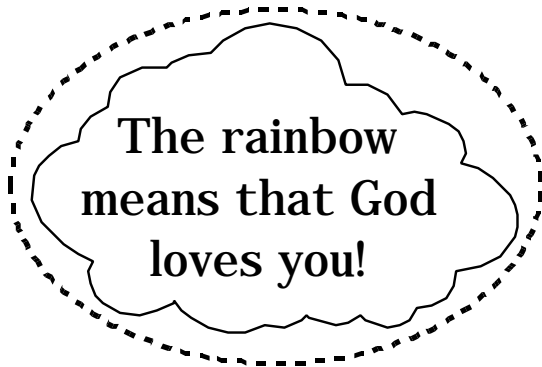

circle stencil

