

Ark Animals

Noah Lesson 2

Lesson Objectives

- The children will name Noah as the man who built the ark.
- The children will match pairs of animals.
- The children will sing a song about obeying God.

Bible Story Text

Genesis 6-8:18

Bible Truth

We obey God.
(Deuteronomy 27:10)

Lesson Plan

Greeting and Registration

Preclass Activity: Preclass Centers

Welcome and Singing

Centers:

Bible Story: Noah Obeys God

Life Application: Go for a Ride

Craft: 'Animal Cracker' Ark

NOTE: Be sure to allow sufficient time for a snack.

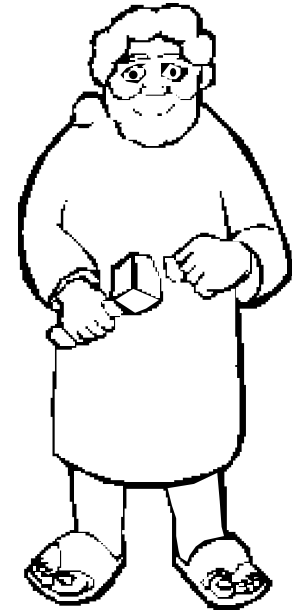

Ark Animals

Preclass Centers

As the children arrive, guide them to a preclass center. Have no more than six children at each center.

Materials

Use the materials previously selected for this unit's preclass centers.

Preparation

1. Be sure to check the condition of the materials selected for this unit's preclass centers prior to set up. Replace any broken toys, or puzzles with missing pieces as necessary.
2. Set up the centers before the children come into the classroom.
3. Assign a teacher to each center and have the teachers stay in those centers until the singing begins.

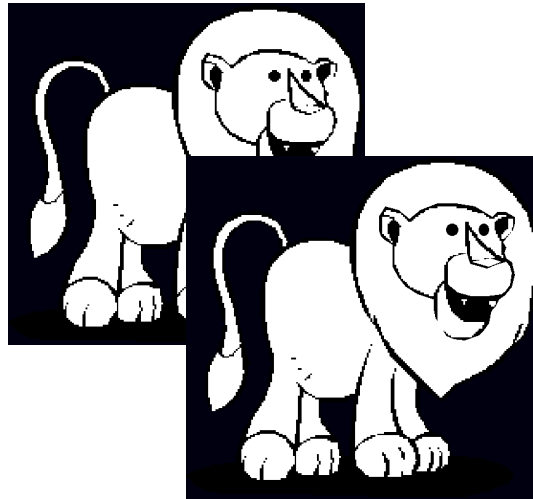

Instructions

Guide the play in each center reinforcing the unit theme.

Teacher Tips

- **IMPORTANT:** Do not allow any small toys in the classroom. First check all toys for size. You can obtain a "safety cylinder" from a pediatrician. Any object that can fit into the cylinder is too small and could cause a child to choke.
- Be involved in the group play and offer guidance as needed.
- Wear comfortable clothes suitable for sitting on the floor.
- Smile! Be childlike in heart and alert in mind.

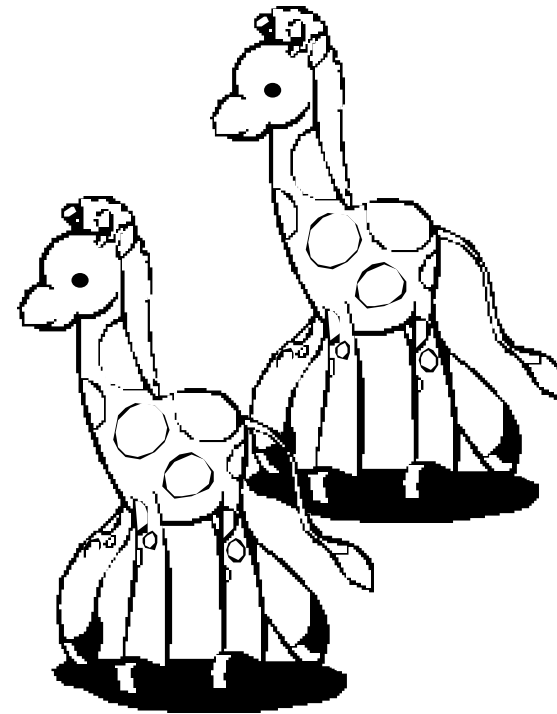

Ark Animals

Noah Obeys God

The children will learn that Noah obeyed God and built the ark.

Bible Story Text

Genesis 6-8:19

Materials

For the teacher:

- Pictures from the Unit 17 Lesson 1, Bible Story
- Bible
- table
- sheet, blanket or tablecloth
- plain cereal, such as Cheerios
- plastic bin
- paper plates
- sheet or blanket for a robe
- 2 scarves
- towel or pillow case for a turban
- plastic hammer
- wooden blocks, cardboard bricks or blocks of wood

Preparation

1. Before the children arrive, put on the Noah costume. Drape the sheet across one shoulder, and let it hang down in the front and back to the floor. Tie a scarf around your waist. Put a towel on your head. Tie a scarf around your head to hold the towel on.
2. Put a sheet over a table so that it hangs down to the floor on three sides making an "ark."
3. Pour the cereal into the plastic bin and place it inside the ark.

Noah Builds an Ark

Open the Bible to Genesis 6. Hello! My name is Noah. You can read about me in the first book in the Bible, called Genesis. Can you say that with me? "Genesis." I want to tell you about something special that God asked me to do. Using the blocks and a hammer, pretend to be working. One day I was working, and God spoke to me. He told me to build a big boat called an ark. He told me to make it very big so it could hold a lot of animals (Genesis 6:13-14). God was going to send a lot of rain, and my boat, the ark, would save my family and all the animals from drowning (Genesis 6:17-21). I had a lot of work to do. I got my family together, and we started building the ark right

away. We obeyed God and worked and worked until finally the ark was ready! (Genesis 6:22). Put away the tools and blocks.

Point to the ark (the table with the cloth covering). God told us to get all the animals ready to go into the ark. It is time to put the elephants into the ark. Show the two elephants. Who wants to hold the elephants? What sound does an elephant make? Give the elephants to a child to hold. Hold the two elephants, and make elephant sounds.

Show the two horses. Who wants to hold the horses? What sounds do the horses make? Give the horses to a child to hold.

Continue distributing the animals until all the children have at least one pair. OK, animals, let's all make our animal sounds. Have the children make the sounds of the animals they are holding.

Then God told me to load all of the animals into the ark (Genesis 7:1). I obeyed God and built the ark. Now it is time for the animals to obey. Come on, animals. It is time to go into the ark. Sing "The Animals Go Marching" from the Unit 17 Song Sheet.

March around the area together as you sing, with the children holding their pairs of animals. Sing one verse for each animal pair.

Instruct the children to put all of the animals into the ark. Wait! What is that sound? It sounds like rain! It is raining outside. But we are inside the ark, safe and sound. I'm so glad we obeyed God and built this ark. Let's tell God thank you. Thank you, God, for keeping us safe inside the ark. Thank you for always protecting us in storms. Amen.

Is anyone hungry? Here is some animal food. Take some cereal out of the bin in the ark and put it on a paper plate for each child. Show the children how to lean down and eat their cereal with no hands like the animals do. Listen! Do you hear anything? It's quiet, it stopped raining. Yeah! Let's all go outside (Genesis 8:18). Go out together and sit outside the ark. Have the children give you the animals.



Ark Animals

Noah
Lesson 2

Conclusion

Ask the following questions to review the story:

- What did Noah build? (an ark)
- What is an ark? (a big boat)
- What did God tell Noah to take on the ark with him and his family? (animals)
- Who built the ark? (Noah)
- Did Noah obey God? (yes)

End with the "Ark Fingerplay" from the Unit 17 Song Sheet.

Teacher Tips

- **IMPORTANT:** Be sure that none of the children have allergies to any of the snacks you may serve during this activity. Ask the parents at registration if their child has any food intolerance or food allergies.
- Use a large table as the ark so that all of the children will fit.
- **IMPORTANT:** Always leave one side of the "ark" open so that people can see in and the children can see out.
- If you have a large class, make extra copies of the animals so there is enough for each child to hold a pair of animals.

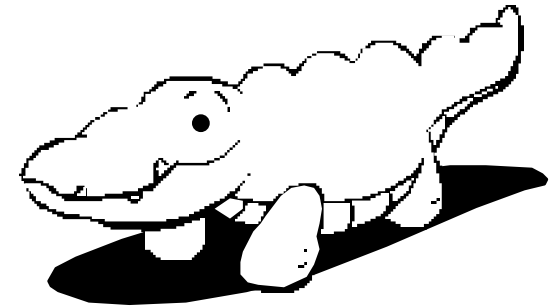
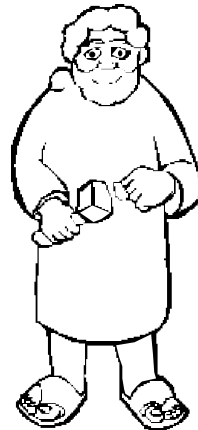
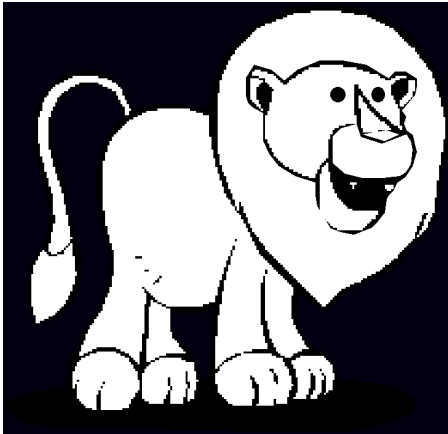

Ark Animals

Go for a Ride

The children will reenact the story of Noah bringing the animals into the ark.

Bible Truth

We obey God.
(Deuteronomy 27:10)

Materials

For the teacher:

- cards from the Unit 17 Lesson 1, Life Application
- ark from the Unit 17 Lesson 1, Life Application
- Bible

Preparation

Familiarize yourself with the activity.

Instructions

1. Show the children the Ark. Who can tell me what this is? Right, it is an ark! Who built the ark? Show Noah. Noah did! Who told Noah to build the ark? That's right! God did. Who remembers what God told Noah to put inside the ark? Animals! Let's look at some of the animals that God told Noah to put in the ark.
2. Show the children each animal and ask them to name the animal and make the sound or motion that it makes.
3. Give each child two cards. Make sure that each child gets two different animals.
4. Ask the children; Who has Noah? Then find the child with Noah's wife. Have these two children walk Noah and his wife up the ramp and into the ark.
5. Continue boarding the animal pairs by asking for them one by one. Who has a monkey? Who has the other monkey? Ok, it's their turn to go into the ark.
6. Distribute any of the remaining cards and continue boarding the animals until they are all on the ark.
7. Sing "Faithful Noah" from the Unit 17 Song Sheet.

Bible Truth Activity

Point to the Ark. When God told Noah to build the ark, did Noah obey God? Yes, he did! Open the Bible. The Bible says we should obey God. Jonathan, will you obey God? Ask each child if they will obey God. Let's all say our Bible Truth together; "We obey God." Hold up the Bible. We obey God when we obey the Bible. Repeat the verse with the children a few times.

Conclusion

Let's talk to God. Dear God, please help us to love and obey you. Please help us to obey your word, the Bible. In Jesus' name we pray. Amen.

Who are you going to tell about Bible class today? What are you going to tell them?

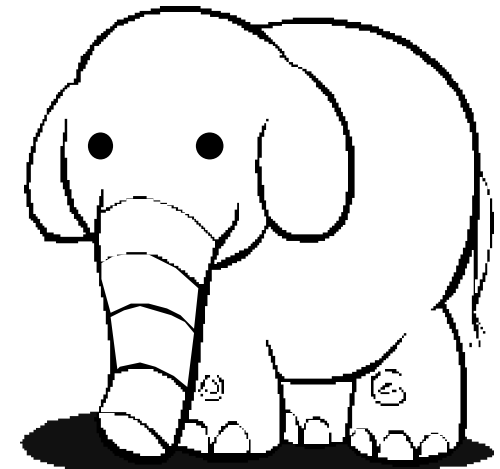

We obey God.



C
r
a
f
t

Ark Animals

'Animal Cracker' Ark

The children will make arks with animal crackers to help them remember Noah and the ark.

Materials

For each child:

- 1 piece of brown construction paper
- 3 craft sticks
- glue stick
- crayons

For the teacher:

- scissors
- animal-shaped crackers
- black marker
- plastic wrap
- white tacky glue or white glue

Reproducible Pages:

- Page A, 1 copy for the teacher

Preparation

1. Cut out the ark stencil from the copy of Reproducible Page A.
2. Make an ark for each child as follows:
 - A. Fold a piece of brown construction paper in half.
 - B. Place the bottom of the ark stencil against the folded edge of the construction paper, and then trace the ark. See Figure A.
 - C. Cut out an ark from brown construction paper. NOTE: Do not cut along the folded edge of the construction paper.
 - D. Write "Noah obeyed God!" near the top of the ark.
3. Wrap four animal shaped crackers tightly in plastic wrap for each child.
4. Make a model of the craft following the instructions.

Noah
Lesson 2

Instructions

1. Show the children the model of the craft. Who built the ark? That's right, Noah built the ark. Noah obeyed God and built the ark! It makes God happy when we obey him. You can make your own ark and that will remind you to obey God.
2. Give each child a folded ark and some crayons. Have the children color their arks.
3. Help each child to glue the edges of their arks together. NOTE: Leave the top open as a pocket. See Figure B.
4. Put three lines of tacky glue on the front of each ark. Give each child three craft sticks to place on the glue lines.
5. Give each child their wrapped animal crackers to place inside their ark.

Conclusion

Using your model, do the "Ark Fingerplay" from the Unit 17 Song Sheet.

Teacher Tips

- **IMPORTANT:** Be sure that none of the children have allergies to any of the snacks you may serve during this activity. Ask the parents at registration if their child has any food intolerance or food allergies.



Ark Animals

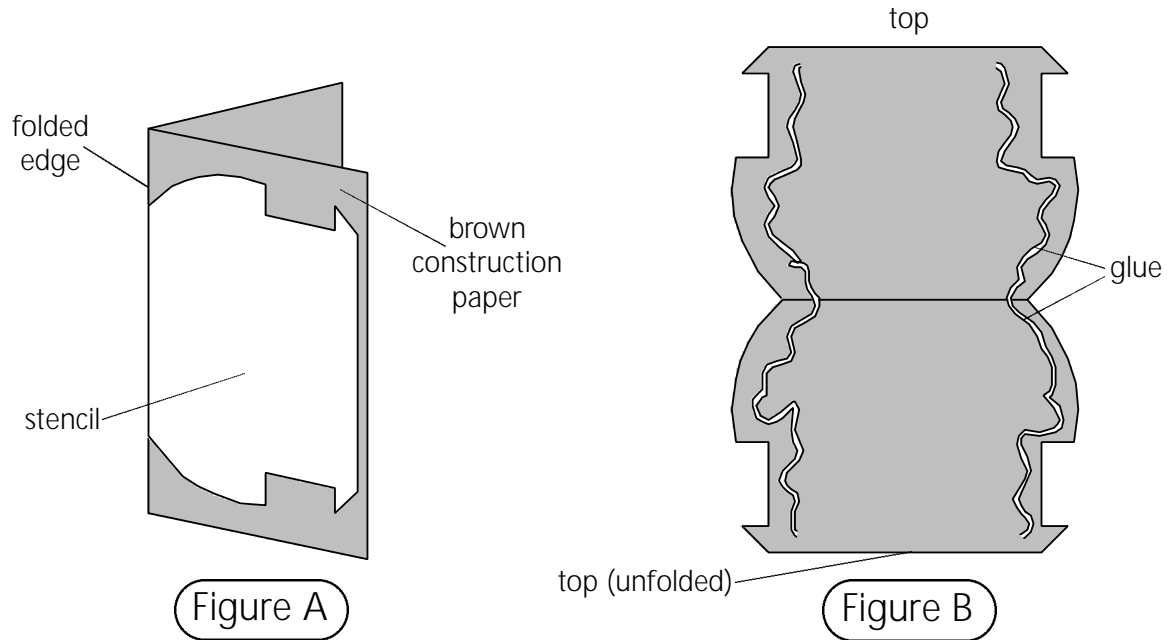

Finished Craft





Lesson Objectives

- The children will name Noah as the man who built the ark.
- The children will match pairs of animals.
- The children will sing a song about obeying God.

Bible Story Text

Genesis 6-8:19

Bible Truth

We obey God.
(Deuteronomy 27:10)

Preclass Centers

As the children arrive, guide them to a pre-class center. Have no more than six children at each center.

Materials

Use the materials previously selected for this unit's preclass centers.

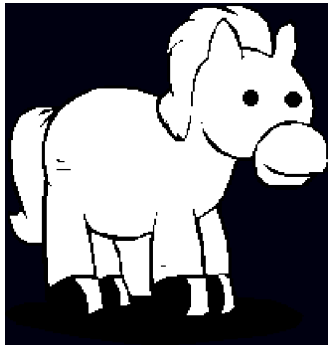

Ark Animals

Noah

Lesson 2

Lesson Plan

Greeting and Registration

Preclass Activity: Preclass Centers

Welcome and Singing

Centers:

Life Application: I Will Obey

Bible Story: Noah Obey's God

Craft: Noah's Hammer

NOTE: Be sure to allow sufficient time for a snack.

Preparation

1. Be sure to check the condition of the materials selected for this unit's preclass centers prior to set up. Replace any broken toys, or puzzles with missing pieces as necessary.
2. Set up the centers before the children come into the classroom.
3. Assign a teacher to each center and have the teachers stay in those centers until the singing begins.

Instructions

Guide the play in each center reinforcing the unit theme.

Teacher Tips

- **IMPORTANT:** Do not allow any small toys in the classroom. First check all toys for size. You can obtain a "safety cylinder" from a pediatrician. Any object that can fit into the cylinder is too small and could cause a child to choke.
- Be involved in the group play and offer guidance as needed.
- Wear comfortable clothes suitable for sitting on the floor.
- Smile! Be childlike in heart and alert in mind.

Life

Application



I Will Obey

This activity will reinforce the lesson that Noah obeyed God and that we should also obey God.

Bible Truth

We obey God.
(Deuteronomy 27:10)

Materials

For the teacher:

- ark pieces from the Unit 17 Lesson 1, Life Application
- Bible
- felt board
- tape

Preparation

1. Roll pieces of tape and stick them to the backs of each of the ark pieces so that they will stick on the felt board.
2. Before the children arrive, arrange the ark correctly on the felt board. See Figure A.

Instructions

Who can tell me what God told Noah to build? (an ark) Did Noah obey God? Yes, he did! What did Noah build? He built an ark. We are going to pretend that we are Noah, and we are going to build an ark. Are we going to do what God said? Yes, we are going to obey God just as Noah did.

Give each child a piece of the ark. Call out each child's name, one at a time, and give a simple instruction of where to put their piece of the ark. Margaret, you have the bottom. The bottom goes first. Can you put your piece on the felt board? Start with the bottom piece and build up to the roof. For some children you may need to point to where they should place their pieces on the feltboard. What are we missing? How is Noah going to see out of the ark? We need a window. Can you place the window in the middle of the ark? Now Noah can see outside! What about a door? How are the animals going to get in? Who has the door? Help the child to place the door in the middle of the bottom of the ark. Encourage the children about how well they listened and obeyed the instructions.

Ark Animals

Noah Lesson 2

Mix up the pieces and hand them out to the children again. We are going to build the ark again, but this time we are going to build it our own way. We're going to see what would happen if we did not listen to and obey God.

Have the children put the different pieces of the ark on the board in any order. Is this a good ark? Which ark was better, the ark like Noah built when he obeyed God, or the ark we built when we did it our own way? That's right, the first ark we built was better because we followed directions. Describe why this ark will not work; the animals won't be able to get in; the boat will sink, etc. When God tells us something, we should obey. God always knows what is right and how to help us. When we do not obey, we will not be happy.

Sing "I Will Obey" from the Unit 17 Song Sheet as you put the ark together in the right order.

Bible Truth Activity

Point to the Ark. When God told Noah to build the ark, did Noah obey God? Yes, he did! Open the Bible. The Bible says we should obey God. Jonathan, will you obey God? Ask each child if they will obey God. Let's all say our Bible Truth together: "We obey God." Hold up the Bible. We obey God when we obey the Bible. Repeat the verse with the children a few times.

Conclusion

Let's talk to God. Dear God, Please help us to love and obey you. Please help us to obey your word, the Bible. In Jesus' name we pray. Amen.

Who are you going to tell about Bible class today? What are you going to tell them?

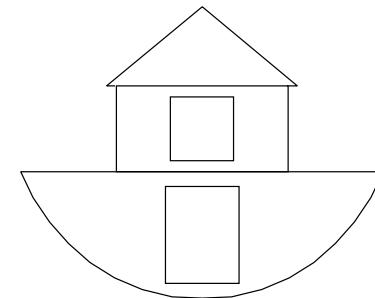

Noah Obeys God

The children will learn that Noah obeyed God and built the ark.

Bible Story Text

Genesis 6-8:19

Materials

For the teacher:

- Pictures from the Unit 17 Lesson 1, Bible Story
- Bible
- table
- sheet, blanket or tablecloth
- plain cereal, such as Cheerios
- plastic bin
- paper plates
- sheet or blanket for a robe
- 2 scarves
- towel or pillow case for a turban
- plastic hammer
- wooden blocks, cardboard bricks or blocks of wood

Preparation

1. Before the children arrive, put on the Noah costume. Drape the sheet across one shoulder, and let it hang down in the front and back to the floor. Tie a scarf around your waist. Put a towel on your head. Tie a scarf around your head to hold the towel on.
2. Put a sheet over a table so that it hangs down to the floor on three sides making an "ark."
3. Pour the cereal into the plastic bin and place it inside the ark.

Noah Builds an Ark

Open the Bible to Genesis 6. Hello! My name is Noah. You can read about me in the first book in the Bible, called Genesis. Can you say that with me? "Genesis." I want to tell you about something special that God asked me to do. Using the blocks and a hammer, pretend to be working. One day I was working, and God spoke to me. He told me to build a big boat called an ark. He told me to make it very big so it could hold a lot of animals (Genesis 6:13-14). God was going to send a lot of rain, and my boat, the ark, would save my family and all the animals from drowning (Genesis 6:17-21). I had a lot of work to do. I got my family together, and we started building the ark right

Ark Animals

Noah Lesson 2

away. We obeyed God and worked and worked until finally the ark was ready! (Genesis 6:22). Put away the tools and blocks.

Point to the ark (the table with the cloth covering). God told us to get all the animals ready to go into the ark. It is time to put the elephants into the ark. Show the two elephants. Who wants to hold the elephants? What sound does an elephant make? Give the elephants to a child to hold. Hold the two elephants, and make elephant sounds.

Show the two horses. Who wants to hold the horses? What sounds do the horses make? Give the horses to a child to hold.

Continue distributing the animals until all the children have at least one pair. OK, animals, let's all make our animal sounds. Have the children make the sounds of the animals they are holding.

Then God told me to load all of the animals into the ark (Genesis 7:1). I obeyed God and built the ark. Now it is time for the animals to obey. Come on, animals. It is time to go into the ark. Sing "The Animals Go Marching" from the Unit 17 Song Sheet. March around the area together as you sing, with the children holding their pairs of animals. Sing one verse for each animal pair.

Instruct the children to put all of the animals into the ark. Wait! What is that sound? It sounds like rain! It is raining outside. But we are inside the ark, safe and sound. I'm so glad we obeyed God and built this ark. Let's tell God thank you. Thank you, God, for keeping us safe inside the ark. Thank you for always protecting us in storms. Amen.

Is anyone hungry? Here is some animal food. Take some cereal out of the bin in the ark and put it on a paper plate for each child. Show the children how to lean down and eat their cereal with no hands like the animals do. Listen! Do you hear anything? It's quiet, it stopped raining. Yeah! Let's all go outside (Genesis 8:18). Go out together and sit outside the ark. Have the children give you the animals.

Ark Animals

Noah Lesson 2

Conclusion

Ask the following questions to review the story:

- What did Noah build? (an ark)
- What is an ark? (a big boat)
- What did God tell Noah to take on the ark with him and his family? (animals)
- Who built the ark? (Noah)
- Did Noah obey God? (yes)

End with the "Ark Fingerplay" from the Unit 17 Song Sheet.

Teacher Tips

- **IMPORTANT:** Be sure that none of the children have allergies to any of the snacks you may serve during this activity. Ask the parents at registration if their child has any food intolerance or food allergies.
- Use a large table as the ark so that all of the children will fit.
- **IMPORTANT:** Always leave one side of the "ark" open so that people can see in and the children can see out.

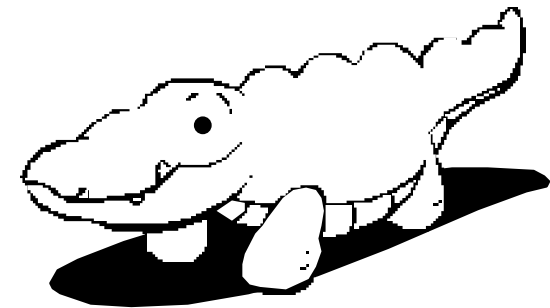
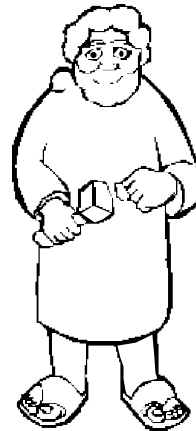
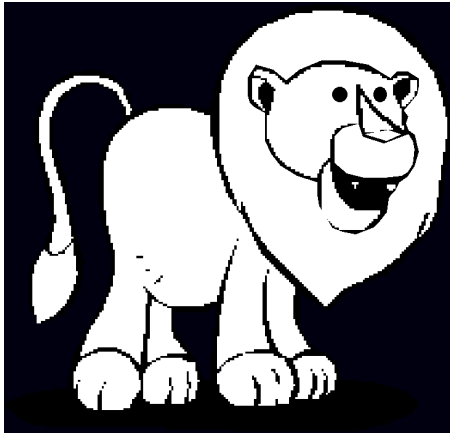

Noah's Hammer

The children will make "hammers" and role play building Noah's ark.

Materials

For each child:

- 1 paint stick
- 2 paper cups, 3 oz.
- glue stick

For the teacher:

- Noah, rainbow or animal stickers
- rice
- clear packing tape
- scissors
- marker

Reproducible Pages:

- Page B, 1 copy for every 5 children

Preparation

1. Cut a $\frac{3}{4}$ " slit from the rim down the side of each cup. See Figure A.
2. Cut out the text boxes from the copies of Reproducible Page B.
3. Make a model of the craft following the instructions.

Instructions

1. Show the children the model craft. This is a hammer. Who in the Bible used a hammer? Noah! What did Noah build with his hammer? Yes, the ark!
2. Give each child a paint stick.
3. Give each child a text box to glue on to one side of the paint stick. Read the words together, and sing a song from the Unit 17 Song Sheet as you work on the craft together.
4. Give each child stickers to decorate their paint sticks.
5. Give each child a cup and some beans to put inside the cup.
6. Help each child to slide the end of the paint stick into the slit in the cup.
7. Help each child to put on the second cup so that the paint stick slides into the slit. See Figure B.
8. Tape the cups together with clear packing tape.
9. Write the children's names on the handles of the hammers.

Ark Animals

Noah Lesson 2

Conclusion

Pretend to hammer, as you sing "Noah Worked with One Hammer" from the Unit 17 Song Sheet.

Teacher Tips

- If you do not have packing tape you will need lots of regular tape to keep the hammer together. Wide tape is preferable.
- It might be helpful to start this craft in the Preclass Activity because of the amount of teacher help that is necessary.
- With younger children, it might be helpful to make the hammers before class, letting the children decorate the handles and spending more time role playing and singing the song.
- Buy blue (1") painters' masking tape from a hardware store and wrap it around the end of the paint stick to distinguish the handles of the hammers.

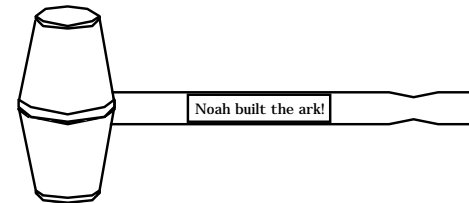

Craft

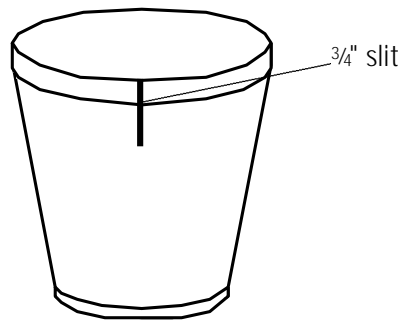

Figure A

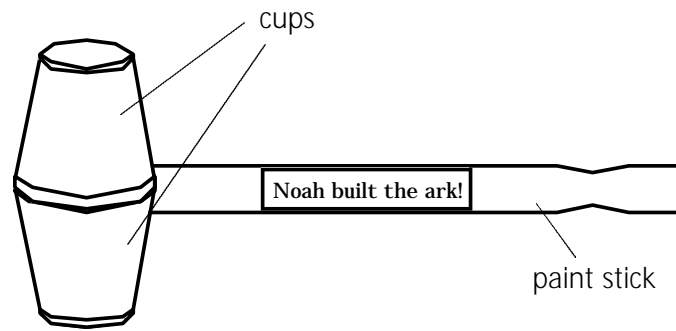
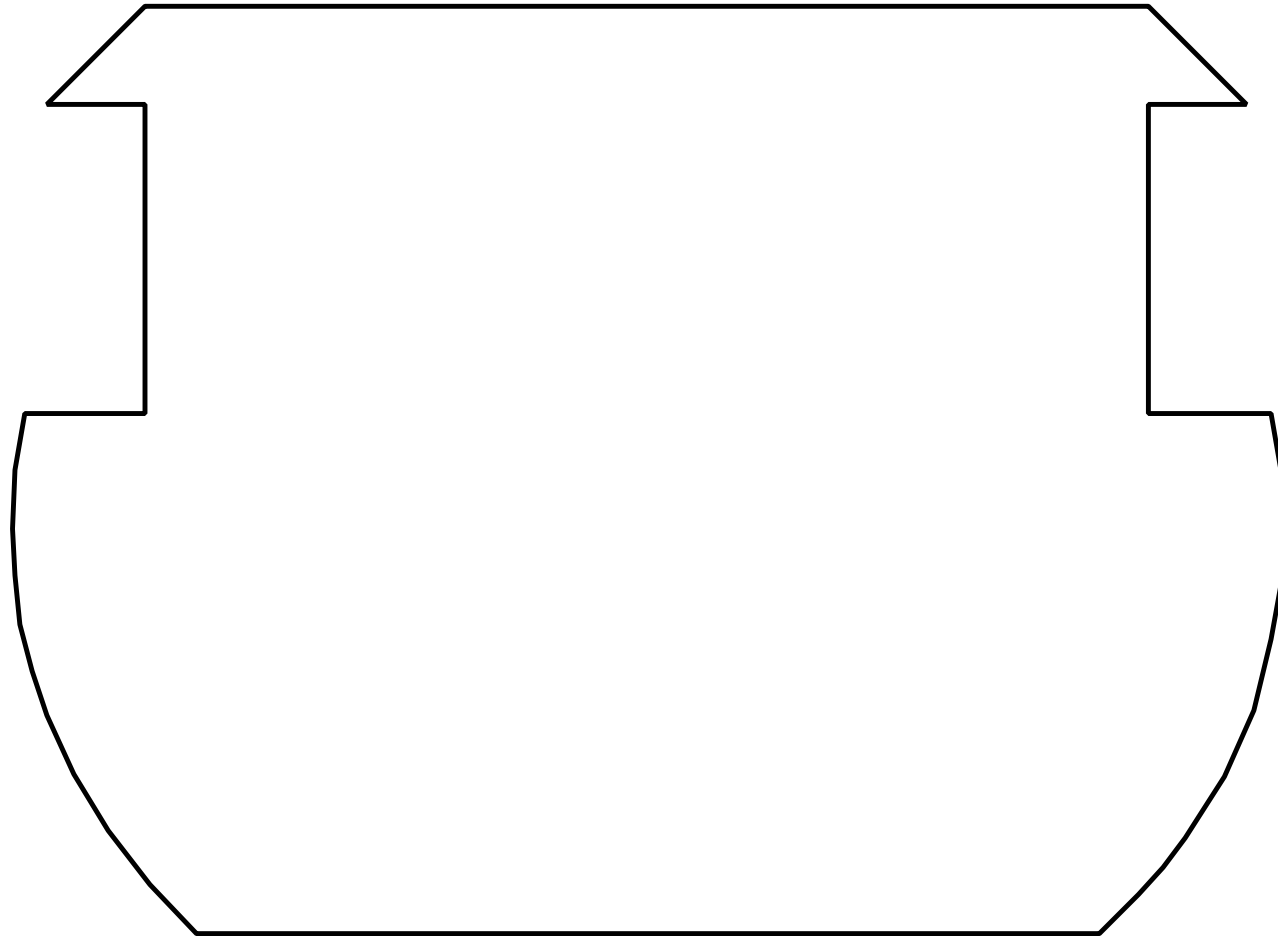

Figure B





R
e
p
r
o
d
u
c
e
d
b
y
e



ark stencil





R
e
p
r
o
d
u
c
t
i
o
n
s

Noah built the ark!

Noah built the ark!

Noah built the ark!

Noah built the ark!

Noah built the ark!

text boxes

