

God Cares for Us

Mary and Joseph
 Lesson 2

Lesson Objectives

- The children will say that God sent baby Jesus
- The children will practice taking care of babies.
- The children will say thank you to God for giving them their families to care for them.

Bible Story Text

Luke 2:1-7

Bible Truth

God sent baby Jesus.
 (Luke 2:11)

Lesson Plan

Greeting and Registration

Preclass Activity: Preclass Centers

Welcome and Singing

Centers:

Bible Story: The Birth of Jesus

Life Application: Baby Care

Craft: Thank-You Mobile

NOTE: Be sure to allow sufficient time for a snack.



God Cares for Us

Preclass Centers

As the children arrive, guide them to a preclass center. Have no more than six children at each center.

Materials

Use the materials previously selected for this unit's preclass centers.

Preparation

1. Be sure to check the condition of the materials selected for this unit's preclass centers prior to set up. Replace any broken toys, or puzzles with missing pieces as necessary.
2. Set up the centers before the children come into the classroom.
3. Assign a teacher to each center and have the teachers stay in those centers until the singing begins.

Instructions

Guide the play in each center reinforcing the unit theme.

Teacher Tips

- **IMPORTANT:** Do not allow any small toys in the classroom. First check all toys for size. You can obtain a "safety cylinder" from a pediatrician. Any object that can fit into the cylinder is too small and could cause a child to choke.
- Be involved in the group play and offer guidance as needed.
- Wear comfortable clothes suitable for sitting on the floor.
- Smile! Be childlike in heart and alert in mind.



God Cares for Us

The Birth of Jesus

The children will hear the story of Jesus being born.

Bible Story Text

Luke 2:1-7

Materials

For the teacher:

- Bible
- nativity scene from the Unit 16 Lesson 1, Bible Story
- tape

Preparation

Familiarize yourself with the story.

Jesus Is Born

Open the Bible. Show the children the Mary and Joseph figures. The Bible says that there was a woman named Mary and a man named Joseph. They loved God very much, and something very special was going to happen to them. An angel told Mary that she was going to have a very special baby. The baby would be God's son and he would be called Jesus!

One day Mary and Joseph found out that they had to take a trip to Bethlehem. The king told everyone they had to go to the town where their parents were born. The king wanted to count everyone in the country (Luke 2:1-5). Let's count all of the boys, 1-2-3 boys. Let's count all of the girls, 1-2-3 girls. Can you hold up that many fingers? 1-2-3! Now let's count all of the boys and girls together, 1-2-3-4-5-6! Can you hold up that many fingers? Mary and Joseph had to go to Bethlehem, so they could be counted.

It was a long way to Bethlehem. Cars were not invented yet so they could not drive. They had to walk or ride a donkey. It took them a long time to get to Bethlehem! When they finally got to Bethlehem, they were very tired and wanted to get a room to sleep in. But there were no rooms where they could sleep. All of the rooms were full. Joseph was sad. He knew that Mary needed a place to rest. He had an idea! They could go into the stable with the animals. It would be warm in the stable. Joseph could make Mary a bed out of hay, so she could rest. Show the nativity scene with Mary and Joseph. That is what they did. They stayed in the stable. And guess what happened that night? Baby Jesus was born! (Luke 2:6-7). Add

baby Jesus to the scene. Do you see the baby? Can you find the baby's mommy? Yes, that is Mary. Can you find Joseph? Yes, that is Joseph. Mary and Joseph took good care of baby Jesus. They put a blanket around him to keep him warm.

"Wah, wah," cried the baby. "Shh, shh," said Mary. "Don't cry." She fed him, pat ted him and rocked baby Jesus to sleep. The animals all gathered around and looked at the sleeping baby.

NOTE: Save the nativity scene for the Unit 16 Lesson 3, Bible Story.

Conclusion

Sing "Baby Jesus Was Born" from the Unit 16 Song Sheet. Ask the following questions to review the story:

- Where did Joseph and Mary go to be counted? (Bethlehem)
- Where was baby Jesus born? (in a stable with the animals)
- Who was his mommy? (Mary)
- Who was his daddy? (Joseph)
- Who sent Jesus? (God)

Teacher Tips

- Use a plastic nativity scene if you have one.
- You may need to replace the clay in the nativity scene.

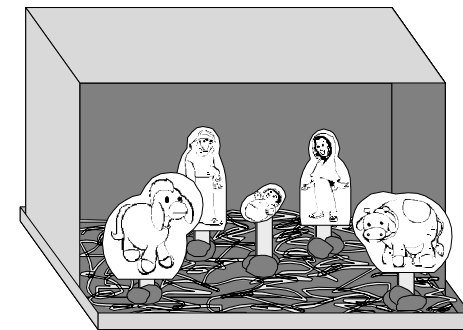

God Cares for Us

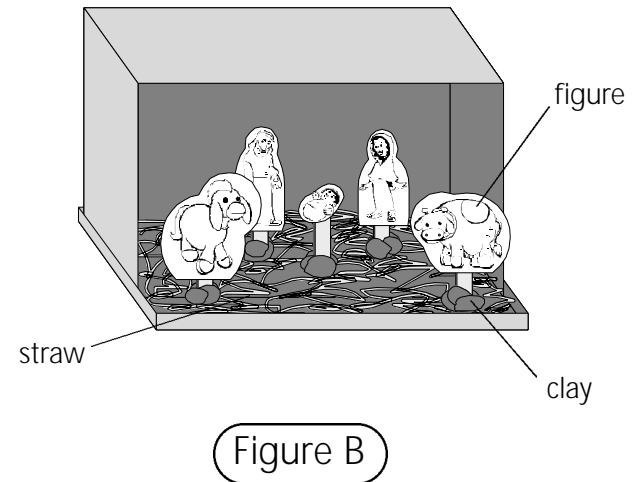
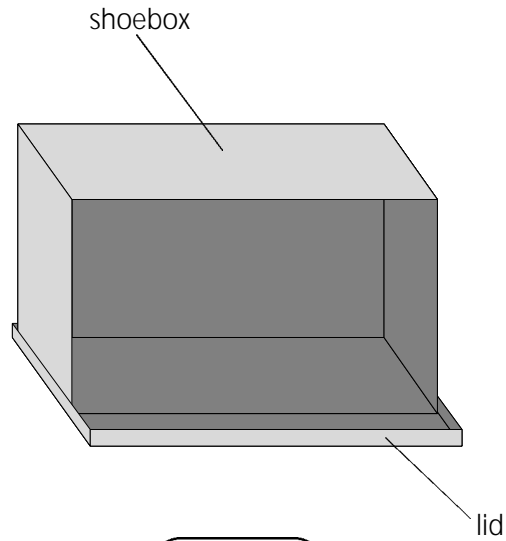

God Cares for Us

Baby Care

The children will role play taking care of a baby and will be reminded of baby Jesus.

Bible Truth

God sent baby Jesus.
(Luke 2:11)

Materials

For each child:

- 1 baby doll
- a doll blanket or a small towel

For the teacher:

- Bible
- a doll bottle

Preparation

1. Ask a mother from your congregation to bring her baby to your class. Ask her to bring a bag of baby care items to show the children how to care for a baby.
2. Review the songs "God Helps Babies" and "This Is the Way" from the Unit 16 Song Sheet.

God Gives us Babies

1. God gives us babies. Do you know who gives babies to daddies and mommies? God does! God gave you to your family.
2. Introduce the mother and her baby. Do you know who gave this baby to this mommy? That's right! God did. Ask the mother to tell the children about the baby; the baby's full name, who the baby was named after, if the baby is a boy or a girl, how old the baby is, how much the baby weighs. Allow the children to ask questions.
3. Have the mother show the children the different items that she uses to care for her baby. If the baby needs a bottle the mother can demonstrate feeding the baby.

4. Give each child a baby doll. Let the children hold, rock, hug, and care for their baby doll. Show the children how to wrap the blanket around the doll. Sing "God Helps Babies" and "This is the Way" as the children play with the dolls. Ask each child, Who takes care of you? Remember their answers so you can pray for them specifically.
5. Have each child take turns feeding their doll with the doll bottle.

Bible Truth Activity

Hold up the Bible. The Bible says, "God sent baby Jesus." Let's all say that together. "God sent baby Jesus." Who is happy that God sent baby Jesus? Who loves baby Jesus?

Conclusion

Let's thank God for giving us babies, and especially for giving us Baby Jesus. Dear God, thank you for giving us babies. Help us to always love and take care of them. Thank you for giving us our families to care for us. Briefly mention in prayer each child's name and the person who they mentioned that takes care of them. Thank you for sending us baby Jesus. In Jesus' name we pray. Amen.

Who are you going to tell about Bible class today? What are you going to tell them?

Teacher Tips

- **IMPORTANT:** Do not allow the children to hold the baby. Depending on the age of the baby and the mother's preference, they may each carefully touch the baby's arm or body.
- **IMPORTANT:** Do not have the mother nurse the baby or change its diaper as a demonstration. This is not appropriate for this class.



God sent baby Jesus.



God Cares for Us

Thank-You Mobile

The children will make a mobile to remind them of the ways that God takes care of them and that baby Jesus is the best gift we could ever receive.

Materials

For each child:

- 1 piece of cardstock or construction paper (12" x 9")
- crayons
- glue stick

For the teacher:

- construction paper
- ribbon in Christmas colors
- Christmas wrapping paper (without Santa on it)
- scissors
- ruler
- marker
- hole punch

Reproducible Pages:

- Page A, 1 copy for each child
- Page B, 1 copy for each child
- Page C, 1 copy for the teacher

Preparation

1. Prepare a mobile present for each child as follows. See Figure A:
 - A. Cover each piece of construction paper with wrapping paper creating a "present."
 - B. Turn the present horizontally. Punch four holes along the bottom of the present.
 - C. Punch one hole in the center of the top of the present.
2. Cut five 10" pieces of ribbon for each child.
3. Prepare a set of mobile shapes for each child as follows:
 - A. Cut out the shape stencils from the copies of Reproducible Page C.
 - B. Trace and cut out one of each shape for each child from construction paper.

4. Cut out the Jesus pictures from the copies of Reproducible Page A.
5. Cut out one set of mobile pictures for each child from the copies of Reproducible Page B.
6. Make a model of the craft following the instructions.

Instructions

1. Show the children the model of the craft. Point to the four different pictures and explain each picture. Explain that God gave us parents to take care of us. God gave baby Jesus parents to take care of him too.
2. Give each child a set of pictures to color.
3. Give each child a set of mobile shapes, and help each child to glue a picture onto each mobile shape.
4. Give each child a mobile present. NOTE: Be sure to explain to the children that these are only pretend presents for the craft. This should help them not to open them.
5. Help each child to glue the large baby Jesus picture onto the middle of the present.
6. As the children are working, punch a hole at the top of each mobile shape.
7. Help each child to thread a piece of ribbon through a mobile shape and then through a hole in the bottom of the mobile present.
8. Tie the ribbons.
9. Tie a ribbon through the hole in the top of the present.

Conclusion

Let each child point to a picture and tell the group one thing he is thankful for. Remind the children that these are gifts that God gives us. They are not gifts we open for Christmas. Explain that the presents of Jesus and our family are the most precious gifts that God could give us! We have these gifts every day, not just at Christmas.

Teacher Tips

- To save time, glue the pictures to the mobile shapes before class begins.



God Cares for Us

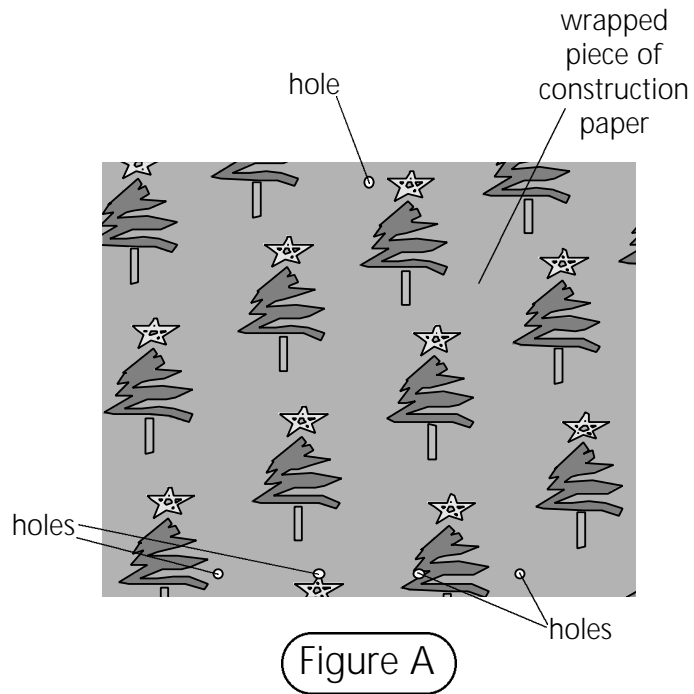

God Cares for Us

Mary and Joseph
Lesson 2

Lesson Objectives

- The children will say that God sent baby Jesus.
- The children will practice taking care of babies.
- The children will say thank you to God for giving them their families to care for them.

Bible Story Text

Luke 2:1-7

Bible Truth

God sent baby Jesus.
(Luke 2:11)

Preclass Centers

As the children arrive, guide them to a pre-class center. Have no more than six children at each center.

Materials

Use the materials previously selected for this unit's preclass centers.

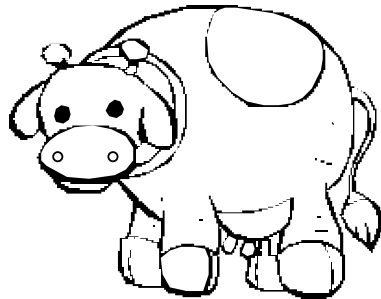

Lesson Plan

Greeting and Registration

Preclass Activity: Preclass Centers

Welcome and Singing

Centers:

Life Application: Hay for His Bed

Bible Story: The Birth of Jesus

Craft: Jesus in a Pocket

NOTE: Be sure to allow sufficient time for a snack.

Preparation

1. Be sure to check the condition of the materials selected for this unit's preclass centers prior to set up. Replace any broken toys, or puzzles with missing pieces as necessary.
2. Set up the centers before the children come into the classroom.
3. Assign a teacher to each center and have the teachers stay in those centers until the singing begins.

Instructions

Guide the play in each center reinforcing the unit theme.

Teacher Tips

- **IMPORTANT:** Do not allow any small toys in the classroom. First check all toys for size. You can obtain a "safety cylinder" from a pediatrician. Any object that can fit into the cylinder is too small and could cause a child to choke.
- Be involved in the group play and offer guidance as needed.
- Wear comfortable clothes suitable for sitting on the floor.
- Smile! Be childlike in heart and alert in mind.

Life

Application



Hay for His Bed

The children will pretend to be animals in the stable where baby Jesus was born.

Bible Truth

God sent baby Jesus.
(Luke 2:11)

Materials

For the teacher:

- star from the Unit 16 Lesson 1, Life Application
- table
- large sheet or tablecloth, large enough to hang over three sides of a table
- small baby doll
- baby blanket
- shoe or other box to hold the baby doll (as a manger)
- tape
- chow mein noodles as "hay" (can be found in the ethnic aisle of the grocery store)
- paper plates

Preparation

1. Before the children arrive set up a stable as follows:
 - A. Drape the sheet over three sides of the table to form a "stable."
 - B. Tape the star to the top edge of the table.
 - C. Wrap the baby doll in the blanket and place it in the shoe box.
 - D. Place the shoe box inside the stable.



Instructions

1. Ask the children what animals might have been with Jesus when he was born. Act out each animal along with the children.
2. Sing "In Bethlehem There Was a Barn" from the Unit 16 Song Sheet.
3. Give each "animal" a paper plate with a few chow mein noodles on it. Explain that animals eat hay, and it is time for the animals' breakfast.
4. Show the children the baby Jesus. Look who was born last night! Baby Jesus! But look in his bed. He has no hay to make his manger bed soft. Let's all share some of our hay with him, so his bed will be soft.
5. Let each child put some "hay" into baby Jesus' manger bed. Say thank you to each animal for sharing with baby Jesus.
6. Let the children pretend to eat some of the "hay," and sing "Away in a Manger" from the Unit 16 Song Sheet.

Bible Truth Activity

Hold the baby doll in your arms. What was the baby's name that God sent? His name was Jesus. God sent baby Jesus. Let's all say that together: "God sent baby Jesus." Jesus was a special baby. He was God's Son!

Conclusion

Let's pray. Thank you, God, for giving us Jesus. Thank you for making babies and mommies and daddies. Thank you for the family that you gave to us. In Jesus' name we pray. Amen.

Some people don't know that Jesus was born. We need to tell them about baby Jesus. Who are you going to tell the story of baby Jesus to?

Teacher Tips

- **IMPORTANT:** Be sure that none of the children have allergies to any of the snacks you may serve during this activity. Ask the parents at registration if their child has any food intolerance or food allergies.
- Use straw or shredded yellow construction paper instead of the chow mein noodles for hay (especially for use in the "manger.")

The Birth of Jesus

The children will hear the story of Jesus being born.

Bible Story Text

Luke 2:1-7

Materials

For the teacher:

- Bible
- nativity scene from the Unit 16 Lesson 1, Bible Story
- tape

Preparation

Familiarize yourself with the story.

Jesus Is Born

Open the Bible. Show the children the Mary and Joseph figures. The Bible says that there was a woman named Mary and a man named Joseph. They loved God very much, and something very special was going to happen to them. An angel told Mary that she was going to have a very special baby. The baby would be God's son and he would be called Jesus!

One day Mary and Joseph found out that they had to take a trip to Bethlehem. The king told everyone they had to go to the town where their parents were born. The king wanted to count everyone in the country (Luke 2:1-5). Let's count all of the boys, 1-2-3 boys. Let's count all of the girls, 1-2-3 girls. Can you hold up that many fingers? 1-2-3! Now let's count all of the boys and girls together, 1-2-3-4-5-6! Can you hold up that many fingers? Mary and Joseph had to go to Bethlehem, so they could be counted.

It was a long way to Bethlehem. Cars were not invented yet so they could not drive. They had to walk or ride a donkey. It took them a long time to get to Bethlehem! When they finally got to Bethlehem, they were very tired and wanted to get a room to sleep in. But there were no rooms where they could sleep. All of the rooms were full. Joseph was sad. He knew that Mary needed a place to rest. He had an idea! They could go into the stable with the animals. It would be warm in the stable. Joseph could make Mary a bed out of hay, so she could rest. Show the nativity scene with Mary and Joseph. That is what they did. They stayed in the stable. And guess what happened that night? Baby Jesus was born! (Luke 2:6-7). Add

baby Jesus to the scene. Do you see the baby? Can you find the baby's mommy? Yes, that is Mary. Can you find Joseph? Yes, that is Joseph. Mary and Joseph took good care of baby Jesus. They put a blanket around him to keep him warm.

"Wah, wah," cried the baby. "Shh, shh," said Mary. "Don't cry." She fed him, pat ted him and rocked baby Jesus to sleep. The animals all gathered around and looked at the sleeping baby.

NOTE: Save the nativity scene for the Unit 16 Lesson 3, Bible Story.

Conclusion

Sing "Baby Jesus Was Born" from the Unit 16 Song Sheet. Ask the following questions to review the story:

- Where did Joseph and Mary go to be counted? (Bethlehem)
- Where was baby Jesus born? (in a stable with the animals)
- Who was his mommy? (Mary)
- Who was his daddy? (Joseph)
- Who sent Jesus? (God)

Teacher Tips

- Use a plastic nativity scene if you have one.
- You may need to replace the clay in the nativity scene.

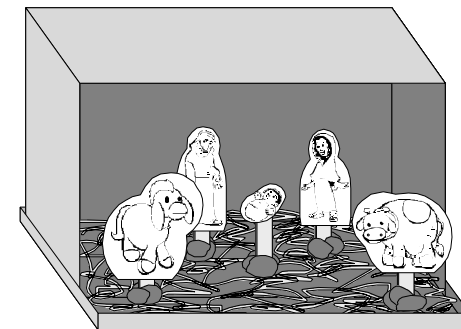

God Cares for Us

Mary and Joseph Lesson 2

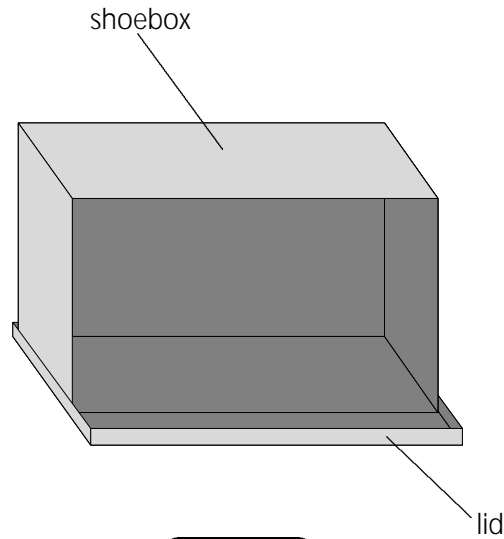

Figure A

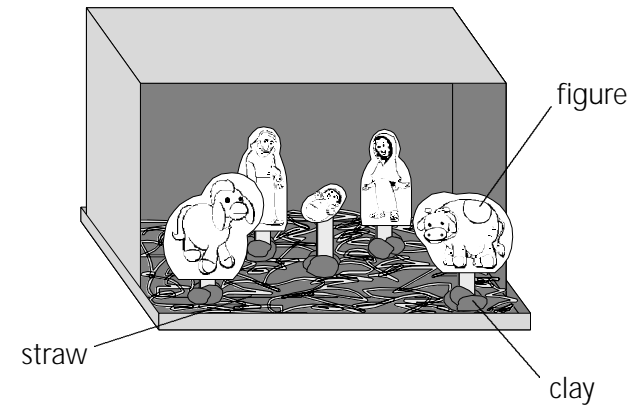

Figure B



Craft

Jesus in a Pocket

The children will make a necklace to remind them that God sent baby Jesus.

Materials

For each child:

- 1½ small paper plates
- 1 facial tissue

For the teacher:

- hole punch
- scissors
- green or red marker
- green and red yarn
- ruler
- tape
- shredded brown paper, can be found at craft stores
- gauze
- tacky glue, can be found at craft stores

Reproducible Pages:

- Page D, 1 copy for each child

Preparation

1. Prepare a paper whole plate pocket for each child as follows.
 - A. Punch 5 evenly spaced holes along the rim on the top half of the whole plate. See Figure A.
 - B. Write on the half paper plate "Thank You, God, for Jesus." with a red or green marker.
 - C. Glue or staple the half plate to the bottom of the whole plate, forming a pocket. The punched holes should all be showing on the top of the whole plate. See Figure B.
2. Cut two 18" pieces of yarn, one red and one green, for each child.
3. Wrap a piece of tape around one end of each piece of yarn to make the stringing easier.
4. Tie each piece of yarn to each of the end holes in the plates. See Figure C.
5. Cut a 5" piece of gauze for each child.
6. Cut out the baby Jesus from the copies of Reproducible Page D.
7. Make a model of the craft following the instructions.

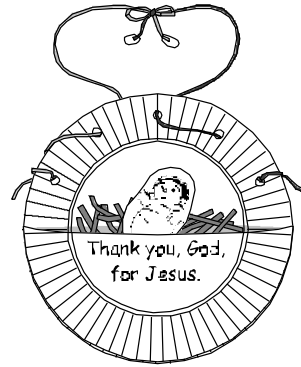

Instructions

1. Show the children the model of the craft. Read it to the children. Show them that baby Jesus can go in and out of the pocket manger.
2. Give each child a paper plate pocket.
3. Help the children to thread their yarn through the holes in the plates. Tie the ends together so the craft can be hung up or worn as a necklace.
4. Give each child a small handful of brown shredded paper to stuff into the pocket as hay.
5. Give each child a baby Jesus to color.
6. Give each child a piece of gauze to glue onto the baby Jesus.
7. Show the children how to place their baby Jesus into the pocket manger and how to take him out to hold him.
8. Write the children's names on their pocket manger and on their baby Jesus.

Conclusion

Sing "Away in a Manger" from the Unit 16 Song Sheet. Talk about how God took care of baby Jesus, by giving him a mother and father and a safe warm bed.

Teacher Tips

- You may need to tape around the edges of the plates to hold them together.
- You may want to secure the hay with a small amount of glue once the children have put the hay into the pocket.
- The children may need help with lacing their yarn. They will not do it perfectly but they will be proud of their work and so will their parents.

Craft

God Cares for Us

Mary and Joseph Lesson 2

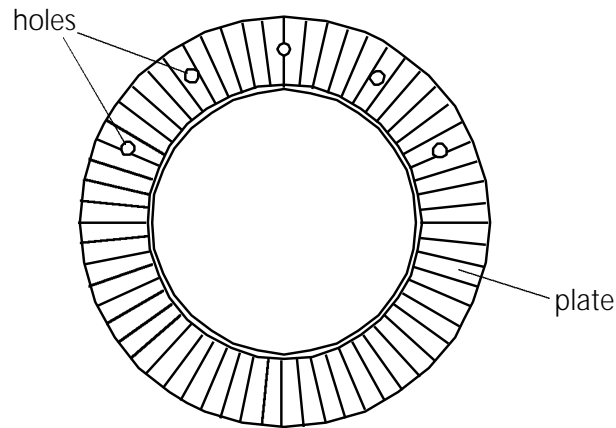

Figure A

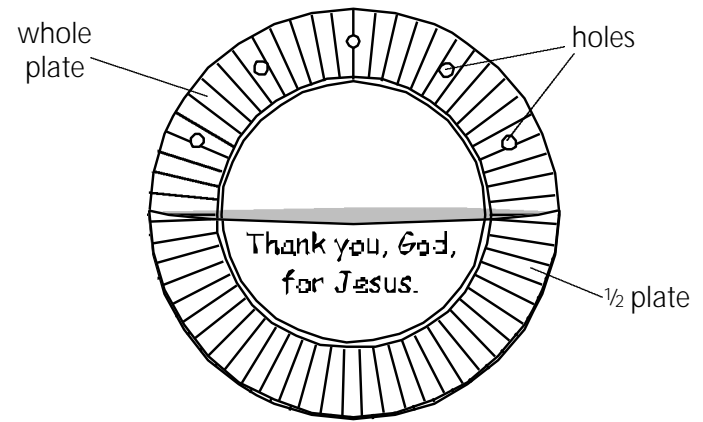

Figure B

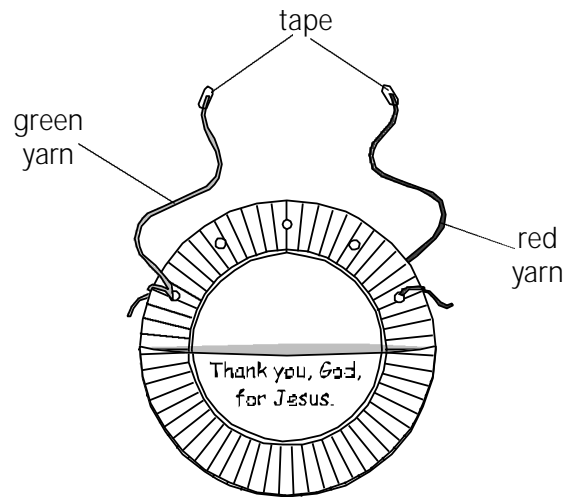
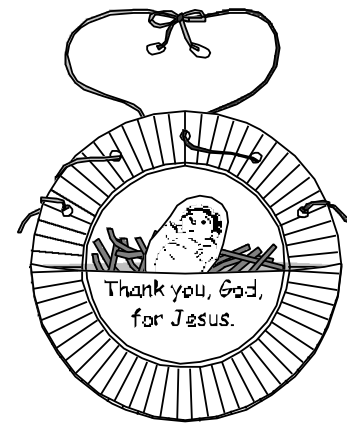

Figure C



Finished Craft





R
e
p
r
o
d
u
c
e
d
b
y
e



Jesus picture





R
E
P
R
O
D
U
C
E
D



mobile pictures

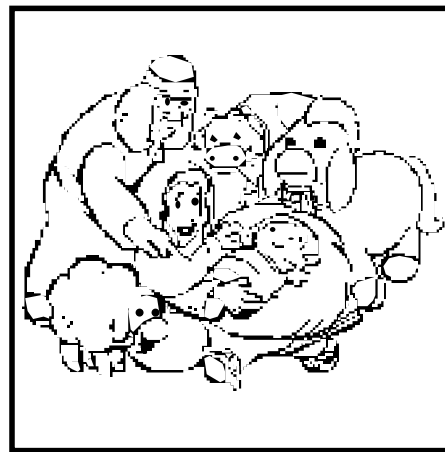
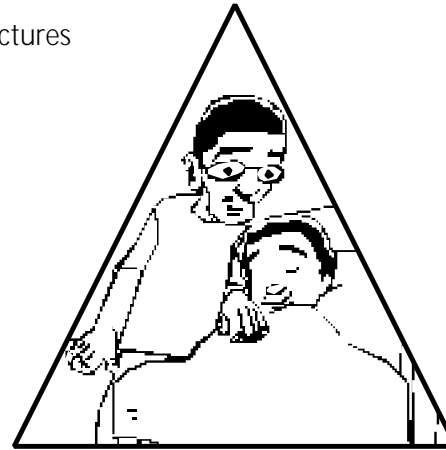



R
E
P
R
O
D
U
C
E
D
I
N
G

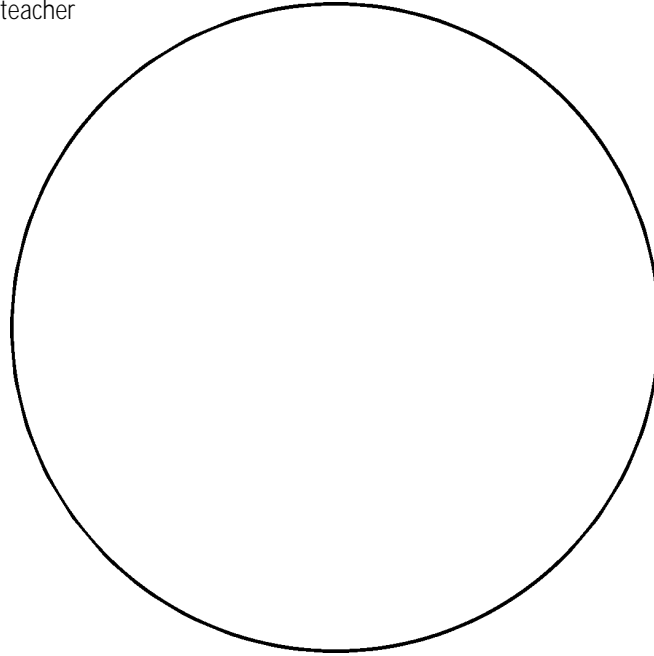

shape stencils

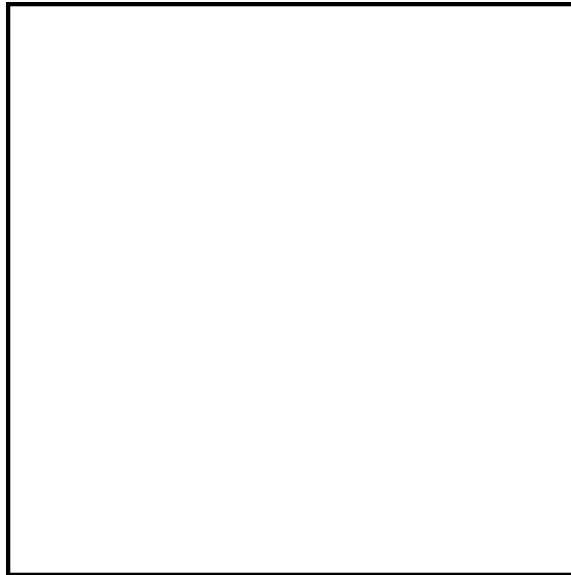
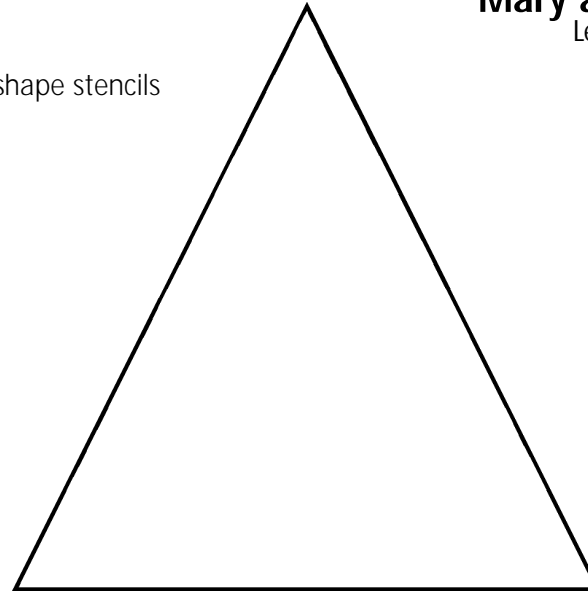



R
e
p
r
o
d
u
c
e
d
b
y
e



baby Jesus

