

Caring for Baby Jesus

Mary and Joseph
 Lesson 1

Lesson Objectives

- The children will say that God sent baby Jesus.
- The children will practice taking care of babies.
- The children will say thank you to God for giving them their families to care for them.

Bible Story Text

Luke 2:1-7

Bible Truth

God sent baby Jesus.
 (Luke 2:11)

Lesson Plan

Greeting and Registration

Preclass Activity: Preclass Centers

Welcome and Singing

Centers:

Bible Story: The Birth of Jesus

Life Application: Baby Care

Craft: Stable Pop-Up

NOTE: Be sure to allow sufficient time for a snack.



Caring for Baby Jesus

Preclass Centers

In the preclass centers children will use language, motor, and cognitive skills, learn to interact with peers and cooperate in small groups.

Select four centers to use this unit. Assign a teacher to set up and supervise each center with no more than six children.

Materials

IMPORTANT: Do not allow any small toys in the classroom. First check all toys for size. You can obtain a "safety cylinder" from a pediatrician. Any object that can fit into the cylinder is too small and could cause a child to choke.

- Housekeeping Center—2 washable dolls (of diverse ethnicity, e.g., black and white), play food, dishes and 2 small blankets
- Story Center—simple books with limited text (cardboard are the most sturdy and durable) and large pillows
- Block Center—set of large blocks, people, animal figures (plastic or wooden) and toy cars
- Puzzle Center—1 puzzle for each child (for twos each puzzle piece itself should be a complete familiar object, for threes most can complete a 20-piece puzzle). **NOTE:** A puzzle should have all the pieces. If a puzzle piece is lost, the entire puzzle should be thrown out.

Instructions

Guide the play in each center reinforcing the unit theme. Refer to the following example for help in directing play and asking relevant questions.

In the Housekeeping Center: Use baby dolls as baby Jesus. Pretend to care for and sing to the baby. Use stuffed animals as animals in the stable.

Teacher Tips

- You may want to try other centers such as transportation, large motor or manipulative.
- Wear comfortable clothes suitable for sitting on the floor.

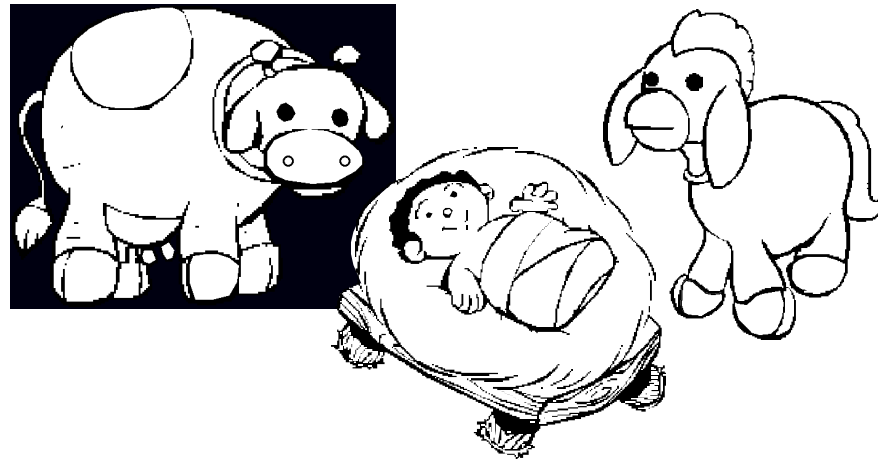

Caring for Baby Jesus

The Birth of Jesus

The children will hear the story of Jesus being born.

Bible Story Text

Luke 2:1-7

Materials

For the teacher:

- Bible
- shoe box with lid
- crayons or markers
- craft sticks
- glue
- clay or Play-Doh
- clean straw or shredded yellow construction paper as "hay"
- clear contact paper or laminate (optional)

Reproducible Pages:

- Page A, 1 copy for the teacher

Preparation

1. Make a shoe box nativity scene as follows:
 - A. Remove the lid and turn the shoe box on its side.
 - B. Place the shoe box inside the lid. See Figure A.
 - C. Cut out and color the figures from the copy of Reproducible Page A.
 - D. Cut each craft stick in half and glue each half to the back of each figure.
 - E. Place pieces of clay on the floor of the shoe box and lid.
 - F. Place the hay around the floor of the box.
 - G. Stick the figures in the clay. See Figure B.

Jesus Is Born

Open the Bible. Show the children the Mary and Joseph figures. The Bible says that there was a woman named Mary and a man named Joseph. They loved God very much, and something very special was going to happen to them. An angel told Mary that she was going to have a very special baby. The baby would be God's son and he would be called Jesus!

One day Mary and Joseph found out that they had to take a trip to Bethlehem. The king told everyone they had to go to the town where their parents were born. The king wanted to count everyone

in the country (Luke 2:1-5). Let's count all of the boys, 1-2-3 boys. Let's count all of the girls, 1-2-3 girls. Can you hold up that many fingers? 1-2-3! Now let's count all of the boys and girls together, 1-2-3-4-5-6! Can you hold up that many fingers? Mary and Joseph had to go to Bethlehem, so they could be counted.

It was a long way to Bethlehem. Cars were not invented yet so they could not drive. They had to walk or ride a donkey. It took them a long time to get to Bethlehem! When they finally got to Bethlehem, they were very tired and wanted to get a room to sleep in. But there were no rooms where they could sleep. All of the rooms were full. Joseph was sad. He knew that Mary needed a place to rest. He had an idea! They could go into the stable with the animals. It would be warm in the stable. Joseph could make Mary a bed out of hay, so she could rest. Show the nativity scene with Mary and Joseph. That is what they did. They stayed in the stable. And guess what happened that night? Baby Jesus was born! (Luke 2:6-7). Add baby Jesus to the scene. Do you see the baby? Can you find the baby's mommy? Yes, that is Mary. Can you find Joseph? Yes, that is Joseph. Mary and Joseph took good care of baby Jesus. They put a blanket around him to keep him warm.

"Wah, wah," cried the baby. "Shh, shh," said Mary. "Don't cry." She fed him, pat ted him and rocked baby Jesus to sleep. The animals all gathered around and looked at the sleeping baby.
NOTE: Save the nativity scene for the Unit 16 Lesson 2, Bible Story.

Conclusion

Sing "Baby Jesus Was Born" from the Unit 16 Song Sheet. Ask the following questions to review the story:

- Where did Joseph and Mary go to be counted? (Bethlehem)
- Where was baby Jesus born? (in a stable with the animals)
- Who was his mommy? (Mary)
- Who was his daddy? (Joseph)
- Who sent Jesus? (God)

Teacher Tips

- Use a plastic nativity scene if you have one.

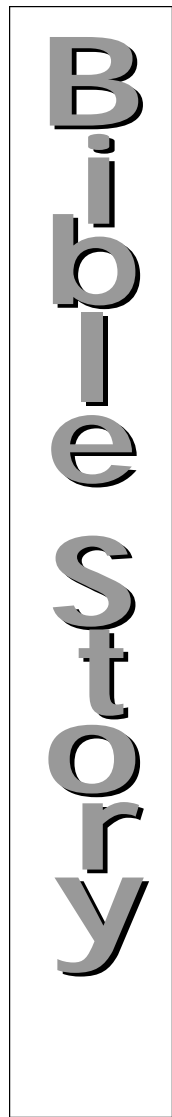

Caring for Baby Jesus

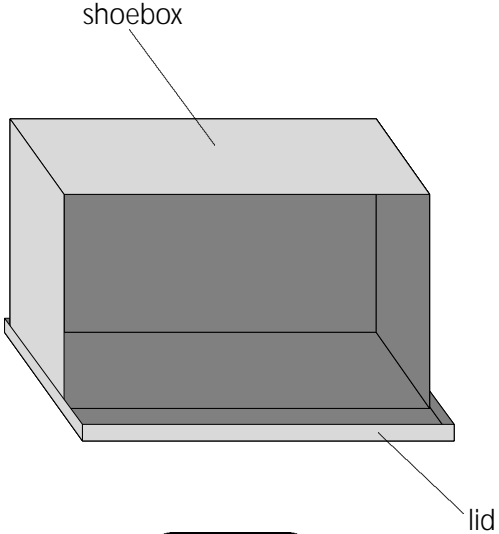

Figure A

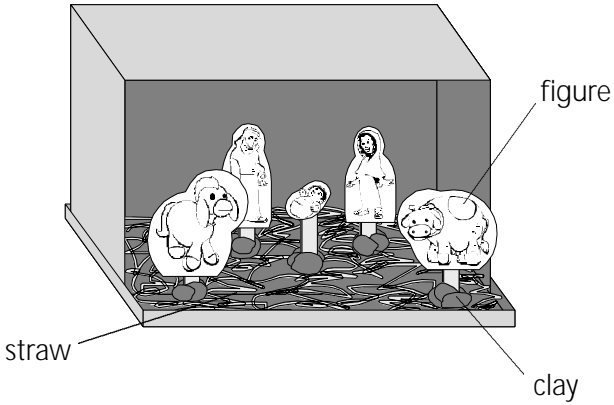

Figure B



Caring for Baby Jesus

Baby Care

The children will role play taking care of a baby and will be reminded of baby Jesus.

Bible Truth

God sent baby Jesus.
(Luke 2:11)

Materials

For each child:

- 1 baby doll
- a doll blanket or a small towel

For the teacher:

- Bible
- a doll bottle

Preparation

1. Ask a mother from your congregation to bring her baby to your class. Ask her to bring a bag of baby care items to show the children how to care for a baby.
2. Review the songs "God Helps Babies" and "This Is the Way" from the Unit 16 Song Sheet.

Instructions

1. God gives us babies. Do you know who gives babies to daddies and mommies? God does! God gave you to your family.
2. Introduce the mother and her baby. Do you know who gave this baby to this mommy? That's right! God did. Ask the mother to tell the children about the baby; the baby's full name, who the baby was named after, if the baby is a boy or a girl, how old the baby is, how much the baby weighs. Allow the children to ask questions.
3. Have the mother show the children the different items that she uses to care for her baby. If the baby needs a bottle the mother can demonstrate feeding the baby.

4. Give each child a baby doll. Let the children hold, rock, hug, and care for their baby doll. Show the children how to wrap the blanket around the doll. Sing "God Helps Babies" and "This is the Way" as the children play with the dolls. Ask each child, Who takes care of you? Remember their answers so you can pray for them specifically.
5. Have each child take turns feeding their doll with the doll bottle.

Bible Truth Activity

Hold up the Bible. The Bible says, "God sent baby Jesus." Let's all say that together. "God sent baby Jesus." Who is happy that God sent baby Jesus? Who loves baby Jesus?

Conclusion

Let's thank God for giving us babies, and especially for giving us baby Jesus. Dear God, thank you for giving us babies. Help us to always love and take care of them. Thank you for giving us our families to care for us. Briefly mention in prayer each child's name and the person who they mentioned that takes care of them. Thank you for sending us baby Jesus. In Jesus' name we pray. Amen.

Who are you going to tell about Bible class today? What are you going to tell them?

Teacher Tips

- **IMPORTANT:** Do not allow the children to hold the baby. Depending on the age of the baby and the mother's preference, they may each carefully touch the baby's arm or body.
- **IMPORTANT:** Do not have the mother nurse the baby or change its diaper as a demonstration. This is not appropriate for this class.



God sent baby Jesus.



Caring for Baby Jesus

Stable Pop-Up

The children will make a three dimensional stable with baby Jesus inside. This will reinforce the lesson that Jesus was born in a stable.

Materials

For each child:

- 1 piece of brown construction paper
- crayons
- glue stick

For the teacher:

- straw or shredded yellow paper as "hay"
- scissors
- utility knife
- ruler
- marker
- fabric glue

Reproducible Pages:

- Page B, 1 copy for each child

Preparation

1. Prepare a stable for each child from brown construction paper.
 - A. Make the roof as follows:
 1. Fold one short end of the paper 3" and make a crease.
 2. Open the paper flat. Measure across the top of the paper 4½" and make a mark. (This will be the center.)
 3. Draw a line from this mark to the corner of the crease on each side. See Figure A.
 4. Cut each of these lines making a point. This will be the roof. See Figure B.
 - B. Make the stable as follows:
 1. Fold the piece of construction paper in half so that the tip of the roof touches the bottom of the paper.
 2. On the center fold, measure 3¾" in from each side of the paper and make a mark.
 3. Draw a 1" line up and down from each mark. Cut those lines using a utility knife to create a tab. See Figure C.

2. Cut out each of the figures and the text boxes from the copies of Reproducible Page B.
3. Fold the animals at the tabs.
4. Glue Mary and Joseph to the back of the stable on either side of the tab. See Figure D.
5. Make a model of the craft following the instructions.

Instructions

1. Show the children the model of the craft. Point to Mary, Joseph and baby Jesus in the manger.
2. Give each child a prepared piece of brown construction paper and baby Jesus. Have the children color Mary, Joseph and Jesus.
3. While the children color, help each child to glue baby Jesus onto the bottom part of the tab. See Figure E.
4. Give each child one of each animal to color.
5. Help the children glue the tabs of the animals to the paper.
6. Give each child a small handful of hay. Help them glue the hay to the paper around the animals' feet.
7. Give each child a text box to glue onto their papers.

Conclusion

Sing "Away in a Manger" from the Unit 16 Song Sheet. As you sing, have the children hold up their crafts and point to the manger, baby Jesus, Mary, etc. As time allows, ask simple questions, and let the children point out the answers. For example, Who can point to baby Jesus' mommy?

Teacher Tips

- Use poster board instead of construction paper to make a sturdier stable.
- Fold the tab at the center before you give the paper to the children.

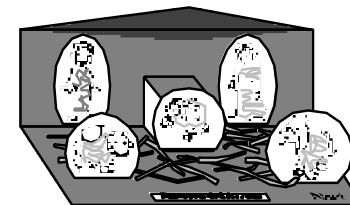

C
r
a
f
t



Caring for Baby Jesus

Mary and Joseph Lesson 1

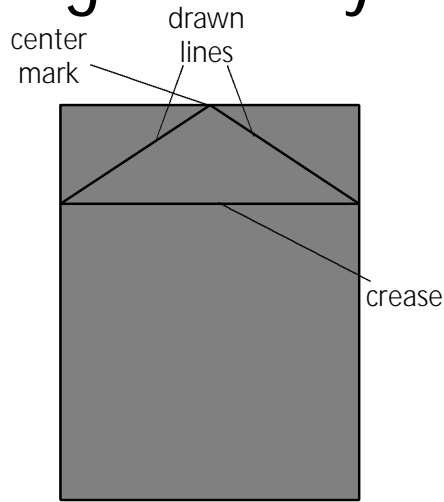

Figure A

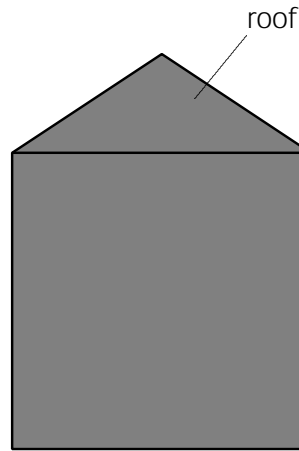

Figure B

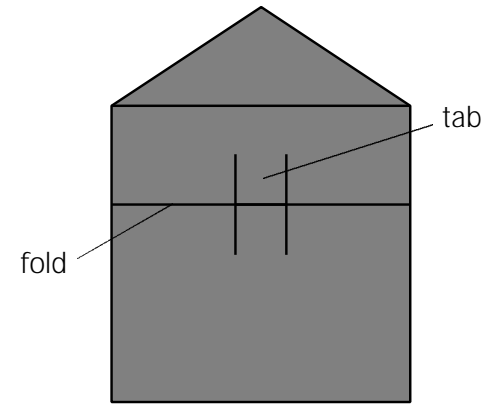

Figure C

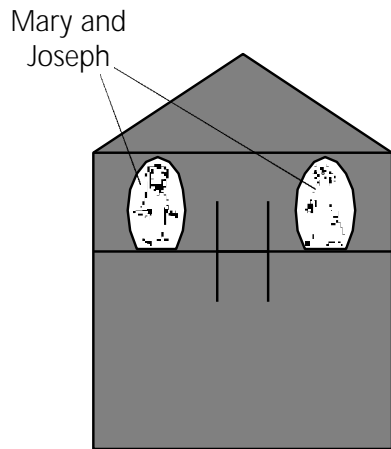

Figure D

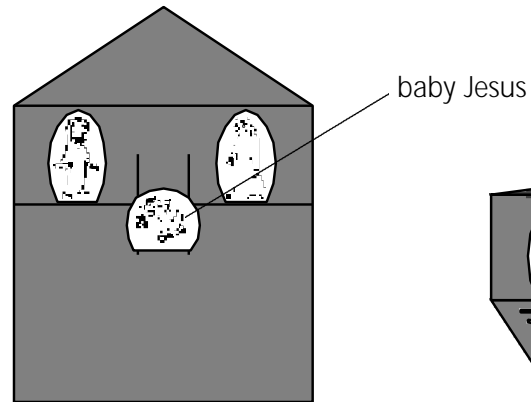
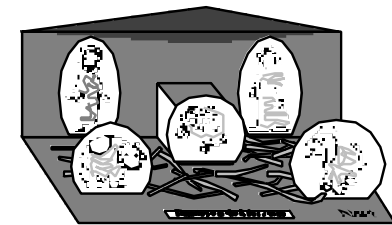

Figure E





Caring for Baby Jesus

Mary and Joseph
Lesson 1

Lesson Objectives

- The children will say that God sent baby Jesus.
- The children will practice taking care of babies.
- The children will say thank you to God for giving them their families to care for them.

Bible Story Text

Luke 2:1-7

Bible Truth

God sent baby Jesus.
(Luke 2:11)

Preclass Centers

In the preclass centers children will use language, motor, and cognitive skills, learn to interact with peers and cooperate in small groups.

Select four centers to use this unit. Assign a teacher to set up and supervise each center with no more than six children.

Materials

IMPORTANT: Do not allow any small toys in the classroom. First check all toys for size. You can obtain a "safety cylinder" from a pediatrician. Any object that can fit into the cylinder is too small and could cause a child to choke.

- Housekeeping Center—2 washable dolls (of diverse ethnicity, e.g., black and white), play food, dishes and 2 small blankets

Lesson Plan

Greeting and Registration

Preclass Activity: Preclass Centers

Welcome and Singing

Centers:

Life Application: Hay for His Bed

Bible Story: The Birth of Jesus

Craft: Baby Jesus

NOTE: Be sure to allow sufficient time for a snack

- Story Center—simple books with limited text (cardboard are the most sturdy and durable) and large pillows
- Block Center—set of large blocks, people, animal figures (plastic or wooden) and toy cars
- Puzzle Center—1 puzzle for each child (for twos each puzzle piece itself should be a complete familiar object, for threes most can complete a 20-piece puzzle). NOTE: A puzzle should have all the pieces. If a puzzle piece is lost, the entire puzzle should be thrown out.

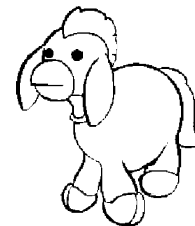

Instructions

Guide the play in each center reinforcing the unit theme. Refer to the following example for help in directing play and asking relevant questions.

In the Housekeeping Center: Use baby dolls as baby Jesus. Pretend to care for and sing to the baby. Use stuffed animals as animals in the stable.

Teacher Tips

- You may want to try other centers such as transportation, large motor or manipulative.
- Wear comfortable clothes suitable for sitting on the floor.

Life

Application



Hay for His Bed

The children will pretend to be animals in the stable where baby Jesus was born.

Bible Truth

God sent baby Jesus.
(Luke 2:11)

Materials

For the teacher:

- 1 piece of poster board or cardboard, 8½" x 11"
- scissors
- aluminum foil
- table
- large sheet or tablecloth, large enough to hang over three sides of a table
- small baby doll
- baby blanket
- shoe box or other box to hold the baby doll (as a manger)
- tape
- chow mein noodles as "hay" (can be found in the ethnic aisle of the grocery store)
- paper plates

Preparation

1. Cut a star out of the poster board and cover it with aluminum foil.
2. Before the children arrive set up a stable as follows:
 - A. Drape the sheet over three sides of the table to form a "stable."
 - B. Tape the star to the top edge of the table.
 - C. Wrap the baby doll in the blanket and place it in the shoe box.
 - D. Place the shoe box inside the stable.

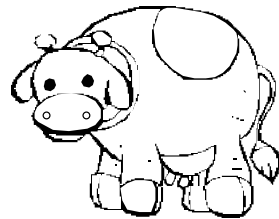

Instructions

1. Ask the children what animals might have been with Jesus when he was born. Act out each animal along with the children.
2. Sing "In Bethlehem There Was a Barn" from the Unit 16 Song Sheet.
3. Give each "animal" a paper plate with a few chow mein noodles on it. Explain that animals eat hay, and it is time for the animals' breakfast.
4. Show the children the baby Jesus. Look who was born last night! Baby Jesus! But look in his bed. He has no hay to make his manger bed soft. Let's all share some of our hay with him, so his bed will be soft.
5. Let each child put some "hay" into baby Jesus' manger bed. Say thank you to each animal for sharing with baby Jesus.
6. Let the children pretend to eat some of the "hay," and sing "Away in a Manger" from the Unit 16 Song Sheet.

NOTE: Save the star for the Unit 16 Lesson 2, Life Application.

Bible Truth Activity

Hold the baby doll in your arms. What was the baby's name that God sent? His name was Jesus. God sent baby Jesus. Let's all say that together: "God sent baby Jesus." Jesus was a special baby. He was God's Son!

Conclusion

Let's pray. Thank you, God, for giving us Jesus. Thank you for making babies and mommies and daddies. Thank you for the family that you gave to us. In Jesus' name we pray. Amen.

Some people don't know that Jesus was born. We need to tell them about baby Jesus. Who are you going to tell the story of baby Jesus to?

Teacher Tips

- **IMPORTANT:** Be sure that none of the children have allergies to any of the snacks you may serve during this activity. Ask the parents at registration if their child has any food intolerance or food allergies.
- Use straw or shredded yellow construction paper instead of the chow mein noodles for hay (especially for use in the "manger.")



The Birth of Jesus

The children will hear the story of Jesus being born.

Bible Story Text

Luke 2:1-7

Materials

For the teacher:

- Bible
- shoe box with lid
- crayons or markers
- craft sticks
- glue
- clay or Play-Doh
- clean straw or shredded yellow construction paper as "hay"
- clear contact paper or laminate (optional)

Reproducible Pages:

- Page A, 1 copy for the teacher

Preparation

1. Make a shoe box nativity scene as follows:
 - A. Remove the lid and turn the shoe box on its side.
 - B. Place the shoe box inside the lid. See Figure A.
 - C. Cut out and color the figures from the copy of Reproducible Page A.
 - D. Cut each craft stick in half and glue each half to the back of each figure.
 - E. Place pieces of clay on the floor of the shoe box and lid.
 - F. Place the hay around the floor of the box.
 - G. Stick the figures in the clay. See Figure B.

Jesus Is Born

Open the Bible. Show the children the Mary and Joseph figures. The Bible says that there was a woman named Mary and a man named Joseph. They loved God very much, and something very special was going to happen to them. An angel told Mary that she was going to have a very special baby. The baby would be God's son and he would be called Jesus!

One day Mary and Joseph found out that they had to take a trip to Bethlehem. The king told everyone they had to go to the town where their parents were born. The king wanted to count everyone

in the country (Luke 2:1-5). Let's count all of the boys, 1-2-3 boys. Let's count all of the girls, 1-2-3 girls. Can you hold up that many fingers? 1-2-3! Now let's count all of the boys and girls together, 1-2-3-4-5-6! Can you hold up that many fingers? Mary and Joseph had to go to Bethlehem, so they could be counted.

It was a long way to Bethlehem. Cars were not invented yet so they could not drive. They had to walk or ride a donkey. It took them a long time to get to Bethlehem! When they finally got to Bethlehem, they were very tired and wanted to get a room to sleep in. But there were no rooms where they could sleep. All of the rooms were full. Joseph was sad. He knew that Mary needed a place to rest. He had an idea! They could go into the stable with the animals. It would be warm in the stable. Joseph could make Mary a bed out of hay, so she could rest. Show the nativity scene with Mary and Joseph. That is what they did. They stayed in the stable. And guess what happened that night? Baby Jesus was born! (Luke 2:6-7). Add baby Jesus to the scene. Do you see the baby? Can you find the baby's mommy? Yes, that is Mary. Can you find Joseph? Yes, that is Joseph. Mary and Joseph took good care of baby Jesus. They put a blanket around him to keep him warm.

"Wah, wah," cried the baby. "Shh, shh," said Mary. "Don't cry." She fed him, pat ted him and rocked baby Jesus to sleep. The animals all gathered around and looked at the sleeping baby.

NOTE: Save the nativity scene for the Unit 16 Lesson 2, Bible Story.

Conclusion

Sing "Baby Jesus Was Born" from the Unit 16 Song Sheet. Ask the following questions to review the story:

- Where did Joseph and Mary go to be counted? (Bethlehem)
- Where was baby Jesus born? (in a stable with the animals)
- Who was his mommy? (Mary)
- Who was his daddy? (Joseph)
- Who sent Jesus? (God)

Teacher Tips

- Use a plastic nativity scene if you have one.

Caring for Baby Jesus

B
i
b
e
S
T
R
O
T
O
R
Y

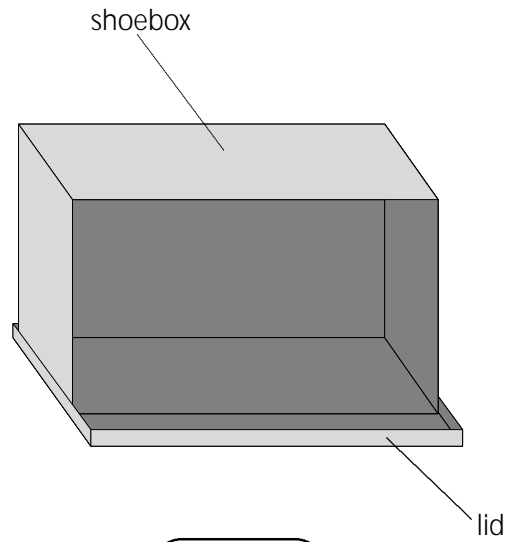

Figure A

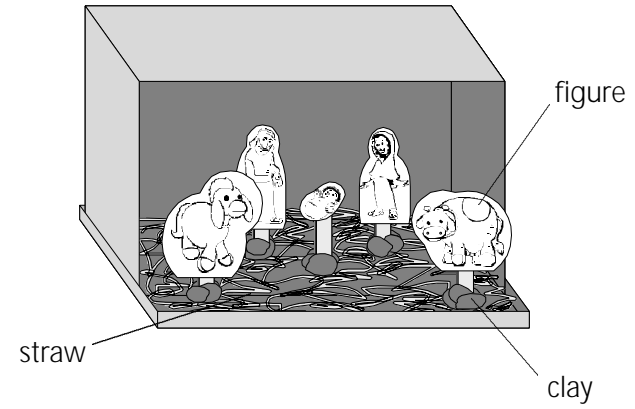

Figure B



C
r
a
f
t

Baby Jesus

The children will make a baby Jesus, wrap him in a blanket and pretend to take care of him.

Materials

For each child:

- 1 old-fashioned clothespin (no spring)
- 1 brown paper lunch bag

For the teacher:

- black marker
- gauze
- yellow construction paper
- ruler
- scissors
- fabric
- tape

Preparation

1. Prepare a "manger" for each child as follows:
 - A. Cut 5" off the top of a lunch bag.
 - B. Fold the top portion of the bag and place it in the bottom of the bag as filler.
 - C. Fold down the sides of the bag until it is about 2½" high. See Figure A.
 - D. Write on the side of the bag "God sent baby Jesus."
2. Cut a 3" x 3" square of fabric for each child as a baby blanket.
3. On the round part of each clothespin draw two closed eyes and a mouth. This will be "baby Jesus."
4. Cut an 8" x 3" piece of gauze for each child.
5. Tape one end of each piece of gauze to the body of a clothespin. See Figure B.
6. Shred the yellow construction paper so that each child will have a small handful.
7. Make a model of the craft following the instructions.

Instructions

1. Show the children the model of the craft. Who was born in a manger? Yes, Jesus. Who sent Jesus to us? Yes, God.
2. Give each child a manger.
3. Give each child a handful of shredded paper to put in the manger as hay.
4. Give each child a baby Jesus with the gauze attached. Show the children how to wrap the gauze around the baby. Tape down the end of the gauze.
5. Have the children place their babies in the mangers.
6. Give each child a blanket to lay over baby Jesus.

Conclusion

Sing "Away in a Manger" from the Unit 16 Song Sheet. Show the children that there was no bed for baby Jesus, so he had to sleep in a manger. Explain that a manger is the thing that holds the animals food. God took care of Jesus. Mary and Joseph took care of baby Jesus and kept him warm and safe in his manger bed.

Teacher Tips

- Instead of shredding your own paper, buy raffia from a craft store or gather shredded paper from an office.

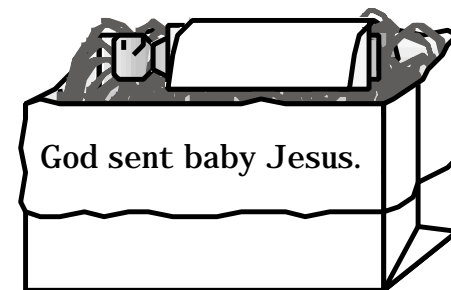

Caring for Baby Jesus

Craft

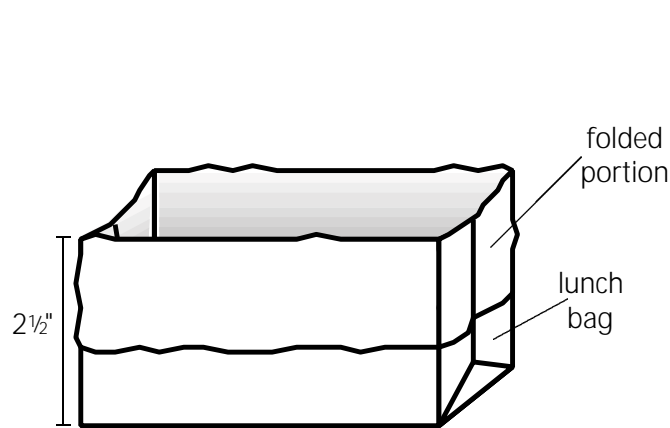

Figure A

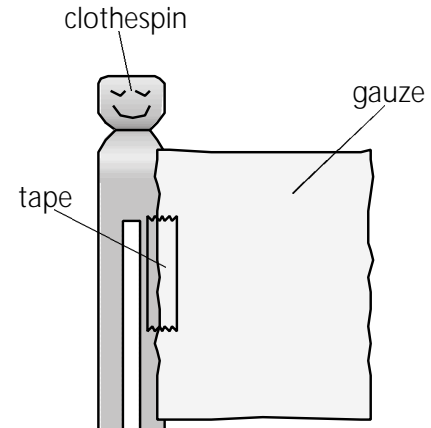
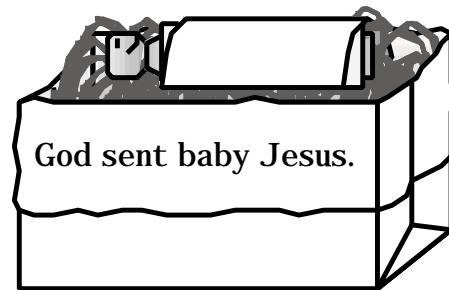

Figure B



Finished Craft





R
e
p
r
o
d
u
c
i
b
l
e

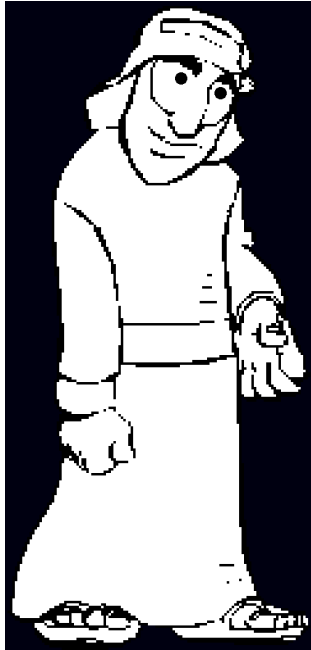



R
E
P
O
R
T
E
R
S
E
-
B
-
C
-
O
-
R
D
-
E
-
R
S

