

David Sings to God

Lesson Objectives

- The children will worship God with song, music and dance.
- The children will say "David" when asked who sang, played music and danced in worship to God.
- The children will learn that singing and dancing is worshiping God.

Bible Story Text

Psalms 101:1; 108:1-3; 138:1

Bible Truth

Sing to the Lord.
(Psalm 96:1)

Lesson Plan

Greeting and Registration

Preclass Activity: Preclass Centers

Welcome and Singing

Centers:

Bible Story: David Worships God

Life Application: Sing and Dance for God

Craft: Sing to the Lord

NOTE: Be sure to allow sufficient time for a snack.



David Sings to God

Preclass Centers

In the preclass centers children will use language, motor, and cognitive skills, learn to interact with peers and cooperate in small groups.

Select four centers to use this unit. Assign a teacher to set up and supervise each center with no more than six children.

Materials

IMPORTANT: Do not allow any small toys in the classroom. First check all toys for size. You can obtain a "safety cylinder" from a pediatrician. Any object that can fit into the cylinder is too small and could cause a child to choke.

- Housekeeping Center—2 washable dolls (of diverse ethnicity, e.g., black and white), play food, dishes and 2 small blankets
- Story Center—simple books with limited text (cardboard are the most sturdy and durable) and large pillows
- Block Center—set of large blocks, people, animal figures (plastic or wooden) and toy cars
- Puzzle Center—1 puzzle for each child (for twos each puzzle piece itself should be a complete familiar object, for threes most can complete a 20-piece puzzle). **NOTE:** A puzzle should have all the pieces. If a puzzle piece is lost, the entire puzzle should be thrown out.

Instructions

Guide the play in each center reinforcing the unit theme. Refer to the following example for help in directing play and asking relevant questions.

In the Housekeeping Center have the children sit in a circle with the dolls. Pretend to have a Bible class with the children and sing songs to God together.

Teacher Tips

- You may want to try other centers such as transportation, large motor or manipulative.
- Wear comfortable clothes suitable for sitting on the floor.



David Sings to God

David Worships God

The children will learn that David worshiped God with song, music and dance.

Bible Story Text

Psalms 101:1, 108:1-3, 138:1

Materials

For the teacher:

- Bible
- 1 shoebox
- 1 cotton ball
- 1 black pipe cleaner
- 1 craft stick
- markers
- blue and green construction paper
- glue
- tape
- scissors
- clear contact paper or laminate (optional)
- cassette tape player
- cassette tape of spiritual music with a beat

Reproducible Pages:

- Page A, 1 copy for the teacher

Preparation

1. To make the diorama:
 - A. Discard the top of the box and turn the box on its side.
 - B. Cover the bottom of the box with green construction paper as "grass."
 - C. Cover the back, sides and top of the box with blue construction paper as "sky."
 - D. Draw a tree and some flowers on the back of the box.
 - E. Draw two eyes on a cotton ball.
 - F. Glue the cotton ball to the back of the box as a sheep.
 - G. Cut four pipe cleaner legs and glue them under the cotton ball as legs.
 - H. Cut a slit along the length of the box where the grass is, leaving 1" on each side.

2. Prepare the David figure as follows:
 - A. Cut out and color the David figure from the copy of Reproducible Page A.
 - B. Tape the craft stick to the back of the David figure so that it sticks down as a handle.
3. Insert the David figure into the slit as shown in Figure A.
4. Have the tape set to an appropriate song and ready to play.

Singing and Dancing

Does anyone here like to sing and dance? Today we are going to hear about a man from the Bible who loved to sing and dance for God. His name was David. Let's all say that together: "David."

Open the Bible. The Bible says that David was a young man who really loved God. He spent lots of time outside taking care of his father's sheep. Show the children the box without the David figure. Point to the sheep inside the shoebox. What sound does a sheep make? Make sheep sounds with the children. Add the David figure, inserting the craft stick through the slit in the box.

David liked to think about God while he took care of the sheep. When he looked at the sky and saw all the beautiful clouds that God made, and when he saw the trees and the beautiful hills of grass, he would think about how incredible God is!

Do you know what David did to show how much he loved God? He sang songs to God, and he danced for God! That is called worshiping God. Let's say that together: "worshiping." Do you think people who are worshiping God are happy or sad? Yes, happy! Do you think God wants us to be happy or sad? Yes, he wants us to be happy! Well, when David saw all that God had made and thought about how much God loved him, it made him so happy that he danced and sang to God.

Turn on the music and move the David figure as if he were dancing. Do you feel like dancing for God? I think that God would love for us to dance and sing to him today! Let's stand up and dance with David.

NOTE: Save the diorama and the David figure for the Unit 15 Lesson 2, Bible Story.

David Sings to God

Conclusion

Let's talk about what we learned today. Who was David? He was a man in the Bible who took care of sheep. Did David love God? Yes! How did David show that he loved God? He showed it by dancing and singing to God! Do you know you can dance and sing all by yourself, like David did? You can also dance and sing with other people, like we danced together in class today? That is called worshiping God, and you can worship God all by yourself or with other people. The next time you hear some fun music, you can sing and dance for God, just like David!

Teacher Tips

- Cover the David figure with clear contact paper to make it last longer.
- Have the children dance in one spot, so they don't wander around the room, disrupting other groups.

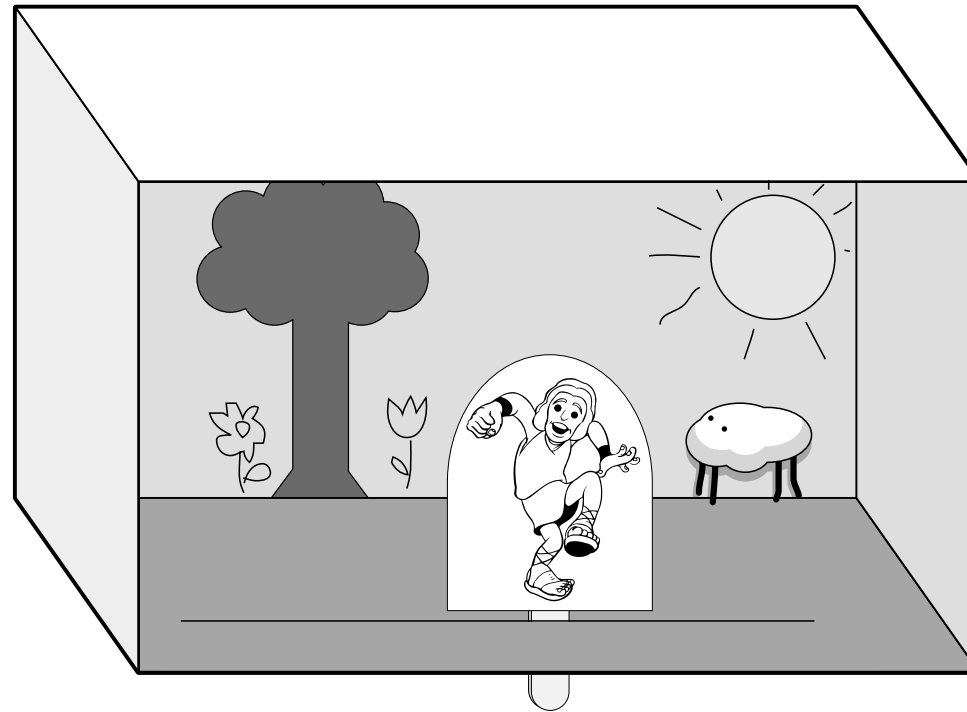

David Sings to God

Sing and Dance for God

The children will sing songs and dance for God.

Bible Truth

Sing to the Lord.
(Psalm 96:1)

Materials

For each child:

- 1 straw

For the teacher:

- Bible
- cassette tape player
- children's tape of spiritual songs
- crepe paper streamers
- tape

Preparation

1. Make a "praise stick" for each child as follows:
 - A. Cut two 20" streamers for each child.
 - B. Tape two streamers to the end of each straw.
2. Learn a simple song from the church songbook that praises God, such as "Sing Amen, Amen." Practice the song until you can sing it confidently and with enthusiasm.
3. Choose two upbeat songs from the children's tape of spiritual songs.
4. Familiarize yourself with the activity.

Instructions

1. Open the Bible. *The Bible says, "Sing to the Lord." In the Bible story today you are learning that David sang to the Lord while he watched his father's sheep. Can everyone say David? The Bible says that David sang and danced to the Lord. That's also called worshipping God. That is what we are going to do today! We are going to sing and dance for God! We are going to worship God.*
2. Sing a simple song of praise with the children. Sing it a few times.

3. Give each of the children a praise stick and show them how to carefully move and twirl it to the music.
 4. Sing and dance with the children using the praise sticks.
 5. Collect the praise sticks from the children.
- NOTE: Save the praise sticks for the Unit 15 Lesson 2, Life Application.

Bible Truth Activity

Who can tell me what we were just doing? Yes, we were singing and dancing.

The Bible says, "Sing to the Lord." Let's say that together: "Sing to the Lord." Who likes to sing to the Lord? Joseph, do you like to sing to the Lord? God loves to hear us sing. He loves when we are happy!

Conclusion

Let's talk to God and thank him.

Dear God, thank you for giving us our legs so that we can dance for you. Thank you for giving us our voices so that we can sing to you. Help us to be like David and sing to you every day! In Jesus' name we pray. Amen.

Who are you going to tell about Bible class today? What are you going to tell them?

Sing to the LORD.

Sing to the Lord.

David Sings to God

Sing to the Lord

The children will make songbooks to remind them to sing to God as David did.

Bible Truth

Sing to the Lord.
(Psalm 96:1)

Materials

For each child:

- 1 piece of construction paper
- crayons
- glue stick
- 2 cotton balls

For the teacher:

- scissors
- markers
- stapler
- tape (optional)

Reproducible Pages:

- Page B, 1 copy for each child
- Page C, 1 copy for each child

Preparation

1. Cut out the David picture from the copies of Reproducible Page B.
2. Make a "songbook" for each child as follows:
 - A. Cut out the four song sheets from the copies of Reproducible Page C.
 - B. Cut each piece of construction paper in half lengthwise.
 - C. Put the two pieces together and then fold them in half forming a "book."
 - D. Staple the book twice along the fold.
 - E. Glue a picture of David to the cover of each book.
3. Make a model of the songbook following the instructions.

Instructions

1. Show the children your model. *Who is this on the front of the songbook? Who watched the sheep and sang songs to God?* Pass the songbook to the children, letting them touch the sheep. Read them the Bible Truth from the cover of the book.

2. Give each of the children a songbook and have them color the picture of David.
3. Help the children glue a cotton ball on each sheep.
4. Help the children glue the song sheets into their songbooks, see Figure A, as follows:
 - A. Give each child one song sheet, and then help the child to glue it onto the first page of the songbook.
 - B. Give each child two more song sheets, and then help the child to glue them to the second and third pages of the songbook.
 - C. Give each child the fourth song sheet, and then help the child to glue it to the fourth page of the songbook.

Conclusion

Using the songbook, sing each of the songs with the children.

Our songbooks say, "Sing to the Lord." Who can tell me who this is in the picture? Yes, it is David. Who can tell me what he is doing? Yes, he's singing to God.

You can take your songbook home and teach these songs to your family. They can sing to the Lord with you!

Teacher Tips

- Place tape over the staples to cover any rough edges.
- If time permits, have the children draw pictures of themselves on the inside back cover of their songbooks.

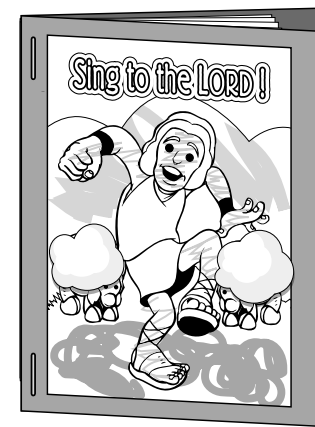

craft

David Sings to God

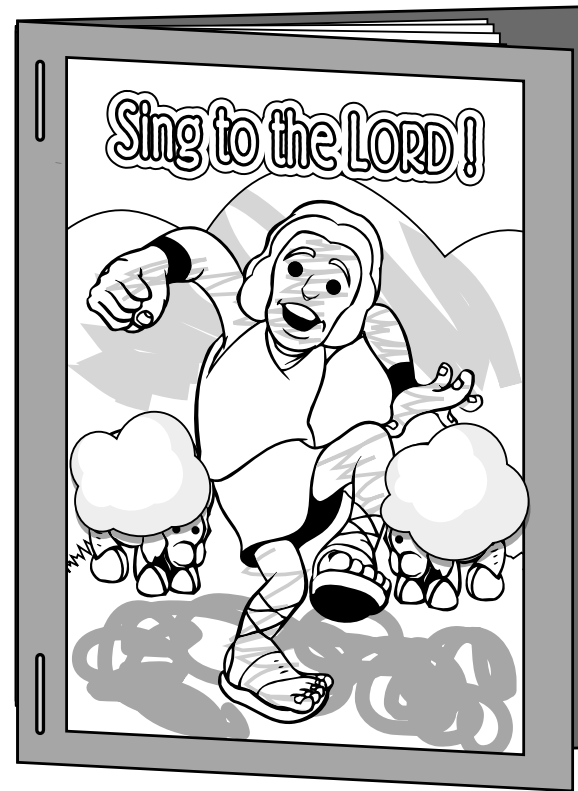
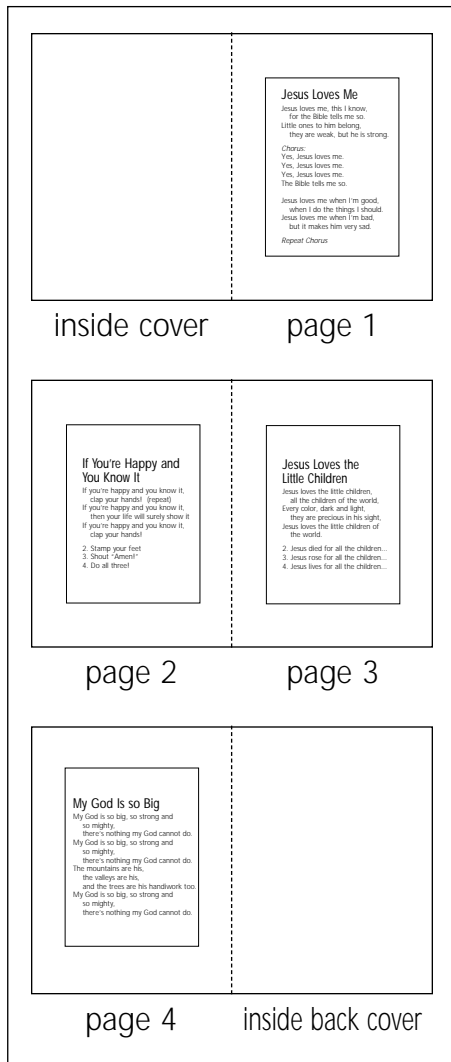

Finished Craft

Figure A





David Sings to God

Lesson Objectives

- The children will worship God with song, music and dance.
- The children will say "David" when asked who sang, played music and danced in worship to God.
- The children will learn that singing and dancing is worshipping God.

Bible Story Text

Psalms 101:1, 108:1-3, 138:1

Bible Truth

Sing to the Lord.
(Psalm 96:1)

Preclass Centers

In the preclass centers children will use language, motor, and cognitive skills, learn to interact with peers and cooperate in small groups.

Select four centers to use this unit.

Assign a teacher to set up and supervise each center with no more than six children.

Materials

IMPORTANT: Do not allow any small toys in the classroom. First check all toys for size. You can obtain a "safety cylinder" from a pediatrician. Any object that can fit into the cylinder is too small and could cause a child to choke.

- Housekeeping Center—2 washable dolls (of diverse ethnicity, e.g., black and white), play food, dishes and 2 small blankets

- Story Center—simple books with limited text (cardboard are the most sturdy and durable) and large pillows
- Block Center—set of large blocks, people, animal figures (plastic or wooden) and toy cars
- Puzzle Center—1 puzzle for each child (for twos each puzzle piece itself should be a complete familiar object, for threes most can complete a 20-piece puzzle). **NOTE:** A puzzle should have all the pieces. If a puzzle piece is lost, the entire puzzle should be thrown out.

Instructions

Guide the play in each center reinforcing the unit theme. Refer to the following example for help in directing play and asking relevant questions.

In the Housekeeping Center have the children sit in a circle with the dolls. Pretend to have a Bible class with the children and sing songs to God together.

Teacher Tips

- You may want to try other centers such as transportation, large motor or manipulative.
- Wear comfortable clothes suitable for sitting on the floor.



Lesson Plan

Greeting and Registration

Preclass Activity: Preclass Centers

Welcome and Singing

Centers:

Life Application: Make a Joyful Noise

Bible Story: David Worships God

Craft: Joyful Noisemaker

NOTE: Be sure to allow sufficient time for a snack.

Life

Application

Make a Joyful Noise

The children will make a joyful noise playing instruments and singing praises to God.

Materials

For each child:

- 1 instrument (real, toy, or homemade)

For the teacher:

- Bible
- cassette tape player
- children's Bible song cassette tape

Preparation

Choose two songs from the tape that are upbeat and cue the tape so that it is ready to play.

Instructions

1. Open the Bible. *The Bible says, "Sing to the Lord." Do you remember who sang to the Lord while he watched his father's sheep? Yes, David! Can everyone say "David?" The Bible says David sang to the Lord. The Bible also says, "Make a joyful noise to the Lord." Sometimes we praise God with singing, sometimes with dancing, sometimes by making a joyful noise!*
2. *First, we are going to make a joyful noise with our voices. Let's all make a joyful noise! Can you say "Amen"?*
3. Sing "If You're Happy and You Know It" from the Unit 15 Song Sheet.
4. *David sang to God because he loved God and wanted to show him that he loved him. When David sang to God, sometimes he would play an instrument. We are going to play these instruments today, and make a joyful noise to God.*
5. Give each child an instrument.
6. Play the tape and have the children play their instruments with the song.
7. Repeat as time allows, trading instruments between each song.

Bible Truth Activity

Today we sang and played instruments for God. Do you remember what song we just sang? The Bible says, "Sing to the Lord." Let's say that together: "Sing to the Lord." Who likes to sing to the Lord? When we sing to the Lord, we are praising God and showing God how happy we are.

Conclusion

Let's thank God for music. Dear God, thank you for giving us instruments, so we can make a joyful noise to you. Thank you for giving us our voices, so we can sing to you. Help us to be like David and sing to you every day! Help us to praise you and worship you every day. In Jesus' name we pray. Amen.

Who are you going to tell about Bible class today? What are you going to tell them?

Teacher Tips

- Here are some ideas for making instruments: a drum from a round container with a plastic cover; a shaker from dried beans or uncooked macaroni inside two paper plates stapled together; a horn from a rolled piece of paper; bells tied together with ribbon or yarn; a guitar from a shoe box with rubber bands strung across the opening.
- If you use instruments that a child will put their mouth on, be sure to clean it with soap and water before another child uses it.
- IMPORTANT: Check any small pieces in making the instruments. Check with the lead teacher to obtain a "safety cylinder" from a pediatrician. Any object that can fit into the cylinder is too small and could cause a child to choke.



David Worships God

The children will learn that David worshiped God with song, music and dance.

Bible Story Text

Psalms 101:1, 108:1-3, 138:1

Materials

For the teacher:

- Bible
- 1 shoebox
- 1 cotton ball
- 1 black pipe cleaner
- 1 craft stick
- markers
- blue and green construction paper
- glue
- tape
- scissors
- clear contact paper or laminate (optional)
- cassette tape player
- cassette tape of spiritual music with a beat

Reproducible Pages:

- Page A, 1 copy for the teacher

Preparation

1. To make the diorama:
 - A. Discard the top of the box and turn the box on its side.
 - B. Cover the bottom of the box with green construction paper as "grass."
 - C. Cover the back, sides and top of the box with blue construction paper as "sky."
 - D. Draw a tree and some flowers on the back of the box.
 - E. Draw two eyes on a cotton ball.
 - F. Glue the cotton ball to the back of the box as a sheep.
 - G. Cut four pipe cleaner legs and glue them under the cotton ball as legs.
 - H. Cut a slit along the length of the box where the grass is, leaving 1" on each side.

2. Prepare the David figure as follows:
 - A. Cut out and color the David figure from the copy of Reproducible Page A.
 - B. Tape the craft stick to the back of the David figure so that it sticks down as a handle.
3. Insert the David figure into the slit as shown in Figure A.
4. Have the tape set to an appropriate song and ready to play.

Singing and Dancing

Does anyone here like to sing and dance? Today we are going to hear about a man from the Bible who loved to sing and dance for God. His name was David. Let's all say that together: "David."

Open the Bible. The Bible says that David was a young man who really loved God. He spent lots of time outside taking care of his father's sheep. Show the children the box without the David figure. Point to the sheep inside the shoebox. What sound does a sheep make? Make sheep sounds with the children. Add the David figure, inserting the craft stick through the slit in the box.

David liked to think about God while he took care of the sheep. When he looked at the sky and saw all the beautiful clouds that God made, and when he saw the trees and the beautiful hills of grass, he would think about how incredible God is!

Do you know what David did to show how much he loved God? He sang songs to God, and he danced for God! That is called worshipping God. Let's say that together: "worshipping." Do you think people who are worshipping God are happy or sad? Yes, happy! Do you think God wants us to be happy or sad? Yes, he wants us to be happy! Well, when David saw all that God had made and thought about how much God loved him, it made him so happy that he danced and sang to God.

Turn on the music and move the David figure as if he were dancing. Do you feel like dancing for God? I think that God would love for us to dance and sing to him today! Let's stand up and dance with David.

NOTE: Save the diorama and the David figure for the Unit 15 Lesson 2, Bible Story.

David Sings to God

Conclusion

Let's talk about what we learned today. Who was David? He was a man in the Bible who took care of sheep. Did David love God? Yes! How did David show that he loved God? He showed it by dancing and singing to God! Do you know you can dance and sing all by yourself, like David did? You can also dance and sing with other people, like we danced together in class today? That is called worshiping God, and you can worship God all by yourself or with other people. The next time you hear some fun music, you can sing and dance for God, just like David!

Teacher Tips

- Cover the David figure with clear contact paper to make it last longer.
- Have the children dance in one spot, so they don't wander around the room, disrupting other groups.

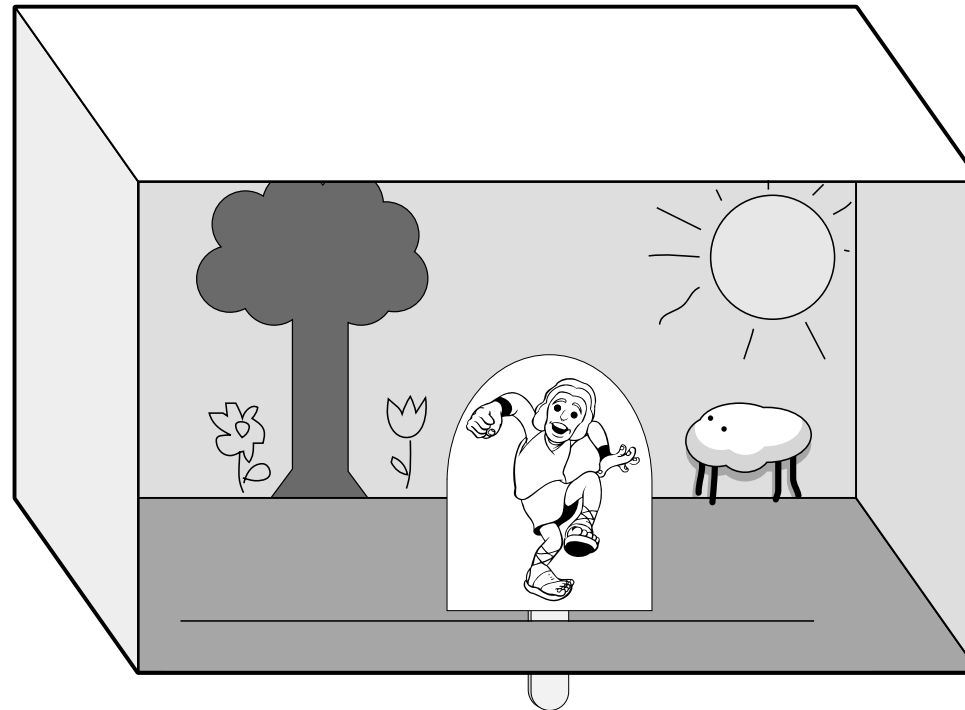

C
r
a
f
t

Joyful Noisemaker

The children will make noisemakers to help them worship God with music.

Materials

For each child:

- a bright-colored paper plate, 7"
- crayons

For the teacher:

- stapler
- hole punch
- markers
- yarn, 2 bright colors
- scissors
- masking tape
- 1 bag of beans

Preparation

1. Prepare a plate for each child as follows:
 - A. Fold each paper plate in half, and then staple it together leaving an opening at one end.
 - B. Punch 8 holes around the edge of each folded paper plate. See Figure A.
 - C. Write, "Sing to the Lord. Psalm 96:1" on the side of the plate.
2. Prepare the yarn for each child as follows:
 - A. Cut two 12" pieces of yarn, one from each color.
 - B. Tie a knot at one end of both pieces of yarn.
 - C. Wrap a piece of masking tape around the opposite ends of both pieces of yarn, making them stiff and easy for the children to work with.
3. Make a model of the craft following the instructions.

Instructions

1. Show the children your model. Read the words written on the noisemaker to them. Have the children repeat the words along with you. Pass the noisemaker around and let each child have a turn shaking it. *Today you are going to make a noisemaker of your very own!*

2. Give each child a prepared paper plate and a handful of beans. Have the child put the beans inside the plate through the opening.
3. Staple the plates so they are completely closed.
4. Help each child thread the yarn through the plates as follows:
 - A. Give the child a piece of yarn. Help the child thread the yarn through the holes in the plate.
 - B. Give the child the other piece of yarn. Help the child thread the yarn through the same holes in the plate.
 - C. Tie the ends of the different color yarn into a knot at both ends.
5. Have the children color their noisemakers.

Conclusion

Sing a song from the Unit 15 Song Sheet with the children, while playing your noisemakers. *God loves for us to worship him with music!*

Teacher Tips

- Make tassels by tying 4" pieces of yarn at the end of each of the longer pieces.
- Push a pencil through the holes around the edges of the plate to make them larger and easy for the children to use.

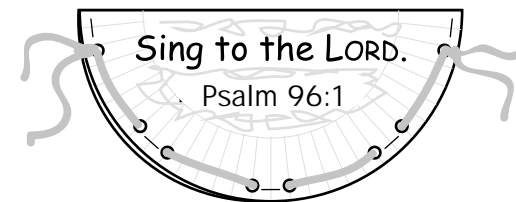

David Sings to God

C
r
a
f
t

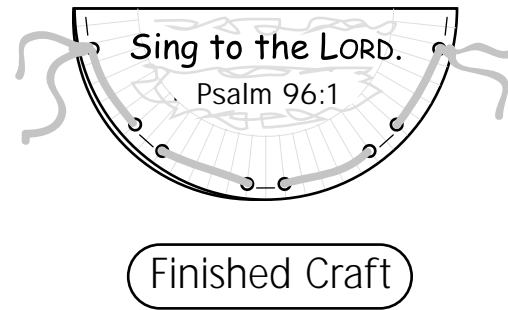
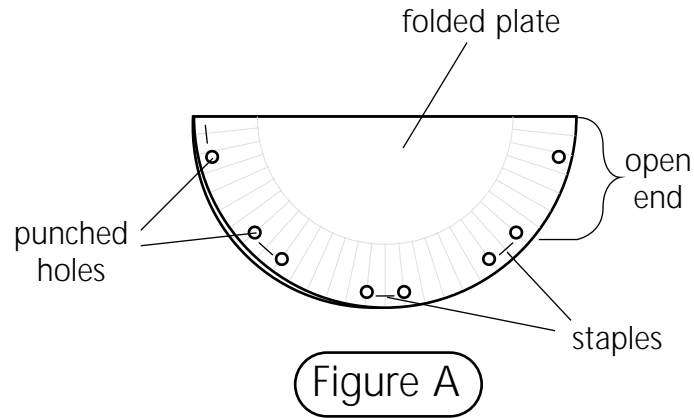



R
e
p
r
o
d
u
c
e
d
i
n
g
e



David figure





R
e
p
r
o
d
u
c
e
d
b
y
e

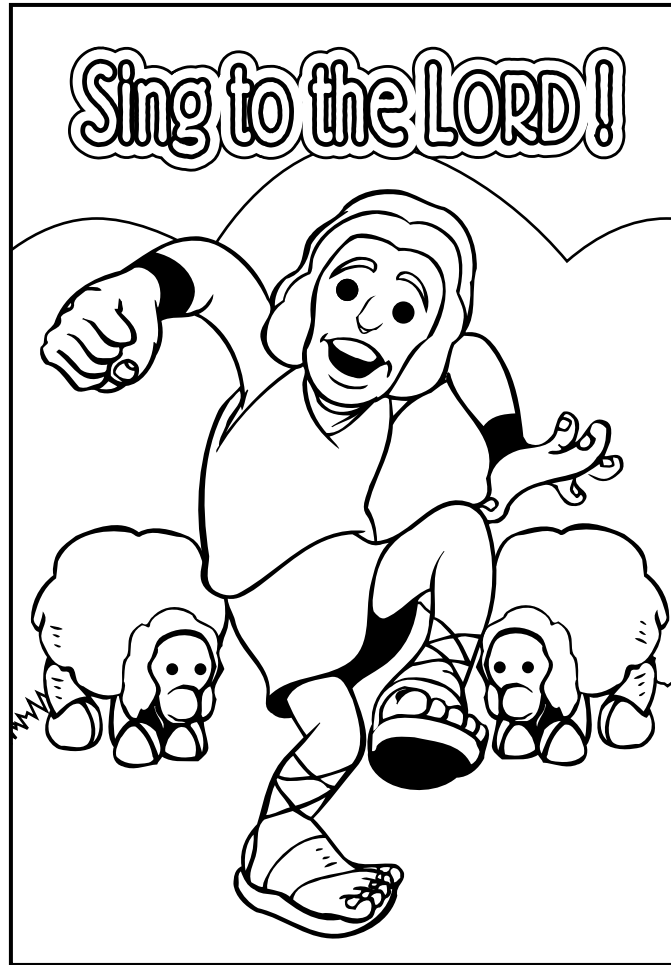

David picture





If You're Happy and You Know It

- If you're happy and you know it,
clap your hands! (repeat)
If you're happy and you know it,
then your life will surely show it
If you're happy and you know it,
clap your hands!
2. Stamp your feet
 3. Shout "Amen!"
 4. Do all three!

Jesus Loves Me

Jesus loves me, this I know,
for the Bible tells me so.
Little ones to him belong,
they are weak, but he is strong.

Chorus:
Yes, Jesus loves me.
Yes, Jesus loves me.
Yes, Jesus loves me.
The Bible tells me so.

Jesus loves me when I'm good,
when I do the things I should.
Jesus loves me when I'm bad,
but it makes him very sad.

Repeat Chorus

My God Is so Big

My God is so big, so strong and
so mighty,
there's nothing my God cannot do.
My God is so big, so strong and
so mighty,
there's nothing my God cannot do.
The mountains are his,
the valleys are his,
and the trees are his handiwork too.
My God is so big, so strong and
so mighty,
there's nothing my God cannot do.

Jesus Loves the Little Children

Jesus loves the little children,
all the children of the world,
Every color, dark and light,
they are precious in his sight,
Jesus loves the little children of
the world.

2. Jesus died for all the children...
3. Jesus rose for all the children...
4. Jesus lives for all the children...

song sheets