

# I Love to Pray

## Lesson Objectives

- The children will understand that praying is how we talk to God.
- The children will learn that Jesus taught his disciples to pray.
- The children will pray.

## Bible Story Text

Luke 11:1-4

## Bible Truth

Pray all the time.  
(1 Thessalonians 5:17)

## Lesson Plan

Greeting and Registration

Preclass Activity: Preclass Centers

Welcome and Singing

Centers:

Bible Story: Jesus Prayed

Life Application: What Time Is It?

Craft: Time to Pray

NOTE: Be sure to allow sufficient time for a snack.



# I Love to Pray

## Preclass Centers

As the children arrive, guide them to a preclass center. Have no more than six children at each center.

### Materials

Use the materials previously selected for this unit's preclass centers.

### Preparation

1. Be sure to check the condition of the materials selected for this unit's preclass centers prior to set up. Replace any broken toys, or puzzles with missing pieces as necessary.
2. Set up the centers before the children come into the classroom.
3. Assign a teacher to each center and have the teachers stay in those centers until the singing begins.

### Instructions

Guide the play in each center reinforcing the unit theme.

### Teacher Tips

- **IMPORTANT:** Do not allow any small toys in the classroom. First check all toys for size. You can obtain a "safety cylinder" from a pediatrician. Any object that can fit into the cylinder is too small and could cause a child to choke.
- Be involved in the group play and offer guidance as needed.
- Wear comfortable clothes suitable for sitting on the floor.
- Smile! Be childlike in heart and alert in mind.



# I Love to Pray

## Jesus Prayed

The children will learn that Jesus prayed and that he taught his disciples to pray.

### Bible Story Text

Luke 11:1-4

### Materials

For the teacher:

- Bible
- felt board
- tape
- pictures from the Unit 14 Lesson 3, Bible Story

### Preparation

Place rolled tape on the back of each picture.

### How to Pray

When we want to talk to God what can we do? Yes, we can pray. Does God like it when we talk to him? Can you show me what you do when you pray? (kneel, close eyes, fold hands, etc.) Do you think Jesus knew how to pray?

Open the Bible. *The Bible says that one day Jesus was praying (Luke 11:1a).* Place the picture of Jesus praying on the felt board.

*The disciples watched him pray.* Place the picture of the disciples on the felt board. *They saw how much Jesus loved God, and how he told God what was in his heart when he prayed. They said, Wow! We want to pray like Jesus.* Look surprised and impressed. *They asked him, Jesus, will you teach us how to pray? (Luke 11:1b).*

*Then Jesus said to the disciples, When you pray say: We love you, God, you are so incredible! You always hear us when we talk to you! (Luke 11:2).* Can you say "incredible"? That's right! God is incredible!

*Then he said to pray for the church, so we can love each other. Can you say, "Thank you for the church"? Can you say, "Love each other"? Let's all give each other a hug!*

*Then Jesus said, Thank you, God, for giving us everything we need every day, like our homes and our families (Luke 11:3).* Give two children the pictures of a home and a family to hold up.

*Thank you, God, for our food that you give us.* Give a child the picture of food. *Father, thank you, for the clothes that you give us to wear (Luke 11:3).* Give a child the picture of clothes.

*Then Jesus taught the disciples to say they were sorry when they did something that was wrong, and to ask God to forgive them (Luke 11:4).*

### Conclusion

*We all need someone like Jesus to teach us how to pray. What did Jesus teach his disciples to do? Yes, he taught them how to pray.*

*There are so many things that we can talk to God about. Who wants to talk to God? What do you want to say? Let each child pray who wants to say something.*

*Do you ever do anything that is not right? Do you ever have to ask your Mommy and God to forgive you? Let's pray about that. Dear God, thank you for forgiving us when we do things that are not right. Thank you for wanting us to talk to you about everything.*



# I Love to Pray



# I Love to Pray

## What Time Is It?

The children will sing about and role-play different activities to reinforce the lesson that they can pray all the time.

### Bible Truth

Pray all the time.  
(1 Thessalonians 5:17)

### Materials

*For the teacher:*

- Bible
- props to act out different activities such as: bowl and spoon, toothbrush, shirt, ball, book, etc.
- clock from the Unit 14 Lesson 3, Life Application
- pictures from the Unit 14 Lesson 3, Life Application

### Preparation

Familiarize yourself with the activity.

### Instructions

Open the Bible. *The Bible says, pray all the time. Today we are going to talk about different times that we pray.*

Hold up the clock. *What is this? Yes, this is a clock. Can everybody say clock? What does a clock tell us? Yes, a clock tells us what time it is. Hold the clock and go from child to child, allowing each child to move the hands of the clock to a new time. Ask each child what time it is.*

Show the children a picture of something that happens in the morning. *Look, what is this little boy doing? He is eating his breakfast. Move the clock's hands to 7:00. It is 7:00, and it is time to eat breakfast. What do we do before we eat our breakfast? That's right, we pray!*

Show each of the magazine pictures in this way, moving the clock hands and asking the children what they should do before each activity shown. The children should answer, pray.

Give each child one of the pictures and sing "It's Time to Pray" from the Unit 14 Song Sheet. As you sing each line of the song, point to the picture that the line describes. (Add or change the lines of the song to fit the pictures that you have.)

If time allows, give each child a prop for role playing. Talk about what each child is doing. Allow that child to move the clock hands to show what time the activity happens. (It does not matter where they move the hands.)

Sing the song again, using lines of the song that describe what each child is role playing.

### Bible Truth Activity

*When we talk to God what are we doing? Yes, we're praying. When should we pray? Hold up the Bible. The Bible says, pray all the time. Let's all say that together: "Pray all the time." Ask each child, when will you pray? Help them to answer "All the time."*

### Conclusion

*Let's talk to God now. Dear God, Thank you that we can talk to you when we get up in the morning, when we eat, when we play, and when we go to bed at night. Please help us to remember to talk to you all the time.*

*Who are you going to tell about Bible class today? What are you going to tell them?*

### Teacher Tips

- Young children cannot tell time yet. Whatever time they say is fine.

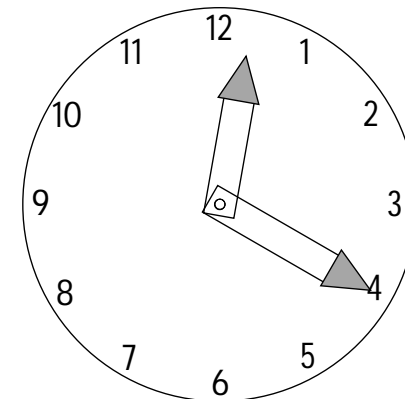

# Pray all the time.



# Craft

## I Love to Pray

### Time to Pray

The children will make clocks reminding them that they can pray anytime.

#### Materials

*For each child:*

- 1 heavy-duty paper plate
- glue stick
- crayons
- 1 brass fastener

*For the teacher:*

- 1 piece of poster board
- scissors
- utility knife
- glue
- black marker
- tape

*Reproducible Pages:*

- Page A, 1 copy for each child
- Page B, 1 copy for each child

#### Preparation

1. Make a clock for each child as follows:
  - A. Cut out the clock face and clock hand stencils from the copy of Reproducible Page A.
  - B. Glue the clock face onto a paper plate.
  - C. Trace and cut out the clock hands from poster board.
  - D. On the longer clock hand, write, "We can always pray."
2. Attach the clock hands to the clock face, see Figure A, for each child as follows:
  - A. Using the utility knife, poke a through small hole in the clock face and in the flat ends of the clock hands.
  - B. Push a brass fastener through the two clock hands and then through the clock face.
  - C. Flatten down the side wings of the brass fastener.
3. Cut out the pictures from the copies of Reproducible Page B.
4. Make a model of the clock following the instructions.

#### Instructions

1. Show the children your craft. Move the clock hands to each time of the day where there is a picture. For example say, *It's 12 noon. Move the clock hands to twelve o'clock. What is it time for? It is time to eat lunch. What do we do before we eat? That's right, we pray to thank God for our food. Talk about what each picture shows. Explain to the children that we can stop and talk to God anytime during our day.*
2. Give each child a clock and their four pictures. Help them to glue their pictures to the correct places on their clock face.
3. Give each child crayons, and then have them color their pictures and their clocks.

#### Conclusion

Using your model, recap what each picture shows. Adjust the hands of your clock to that time. Have the children move the hands of their own clocks to the same time.

If time allows, sing "It's Time to Pray" from the Unit 14 Song Sheet. Substitute the activities written in the verses of the song with the activities pictured on your clock. Move the clock hands as you sing each verse.

#### Teacher Tips

Colored paper plates will enhance this craft.

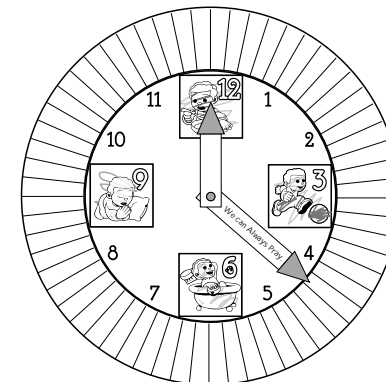

# I Love to Pray

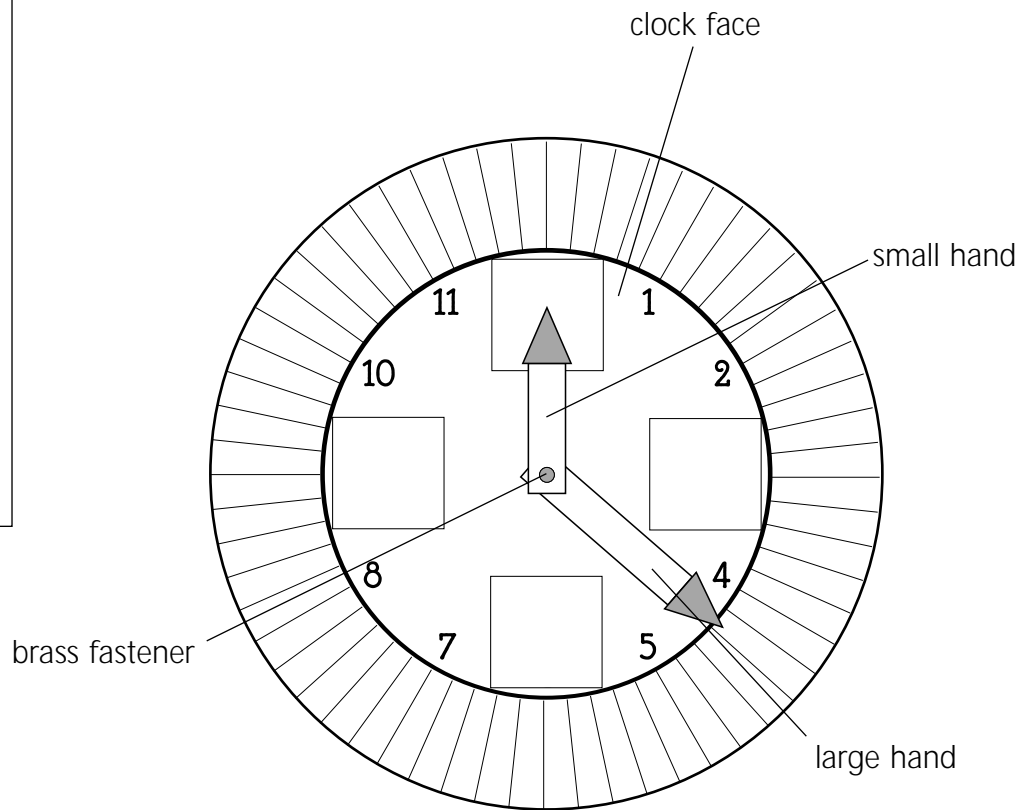
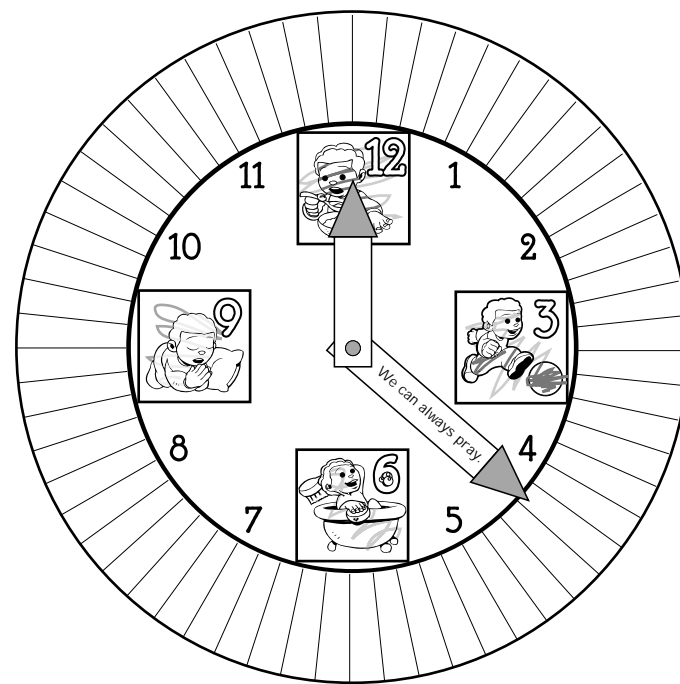

Figure A



Finished Craft





## Lesson Objectives

- The children will understand that praying is how we talk to God.
- The children will learn that Jesus taught his disciples to pray.
- The children will pray.

## Bible Story Text

Luke 11:1-4

## Bible Truth

Pray all the time.  
(1 Thessalonians 5:17)

## Preclass Centers

As the children arrive, guide them to a pre-class center. Have no more than six children at each center.

### Materials

Use the materials previously selected for this unit's preclass centers.

### Preparation

1. Be sure to check the condition of the materials selected for this unit's preclass centers prior to set up. Replace any broken toys, or puzzles with missing pieces as necessary.

2. Set up the centers before the children come into the classroom.
3. Assign a teacher to each center and have the teachers stay in those centers until the singing begins.

### Instructions

Guide the play in each center reinforcing the unit theme.

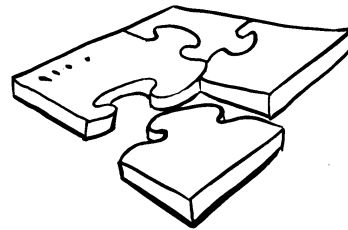

# I Love to Pray

## Prayer Lesson 4

### Lesson Plan

Greeting and Registration

Preclass Activity: Preclass Centers

Welcome and Singing

Centers:

Life Application: Prayers Go Up

Bible Story: Jesus Prayed

Craft: Prayers to God

NOTE: Be sure to allow sufficient time for a snack.

### Teacher Tips

- **IMPORTANT:** Do not allow any small toys in the classroom. First check all toys for size. You can obtain a "safety cylinder" from a pediatrician. Any object that can fit into the cylinder is too small and could cause a child to choke.
- Be involved in the group play and offer guidance as needed.
- Wear comfortable clothes suitable for sitting on the floor.
- Smile! Be childlike in heart and alert in mind.

## Prayers Go Up

This activity will reinforce the lesson that God hears and answers our prayers.

### Bible Truth

Pray all the time.  
(1 Thessalonians 5:17)

### Materials

- Bible
- a bottle of bubbles

### Preparation

1. Learn the finger play "My Prayers Go Up" from the Unit 14 Song Sheet. Practice several times with the motions so that you can do it without reading the words.
2. Familiarize yourself with the activity.

### Instructions

Open the Bible. *The Bible says: pray all the time. Who prays? That's right! We all do! Who do we pray to? We pray to God! Does God hear us when we pray? Yes, he does!* Ask each child what they pray for. If she does not know what to answer you can help by asking, *Do you thank God for your mom or dad?*

Do the finger play "My Prayers Go Up" from the Unit 14 Song Sheet. Repeat the finger play a second time.

Blow some bubbles. *When we pray to God, where do our prayers go? They go up, up to God, just like the bubbles go up! Now, we are going to pretend that these bubbles are our prayers. Maria, we will pretend this is your prayer to God. Let's see where it goes. Where is it going? It is going up, up, up to God!* Do the same with each child. You can blow a few bubbles for each child.

Repeat the finger play inserting the children's names and blowing bubbles so that they can watch them "go up."

# I Love to Pray

## Prayer Lesson 4

### Bible Truth Activity

Hold up the Bible. *The Bible says: pray all the time. Let's all say that together, "Pray all the time." Where do our prayers go? Right, they go up to God! Does God hear our prayers? Yes, he does! Does God love it when we pray to him? Yes, he always loves it when we pray to him.*

We can tell our friends and family that they can always pray to God.

### Conclusion

*Let's talk to God now. Dear God, Thank you that we can pray to you any time we want to. Thank you that our prayers go up to you, and that you hear them. Thank you for letting us talk to you. We love you! In Jesus name we pray. Amen.*

### Teacher Tip

**IMPORTANT:** Do not allow the children to blow bubbles. It is unsanitary to share the wand, and young children can accidentally inhale or swallow the soapy bubbles.

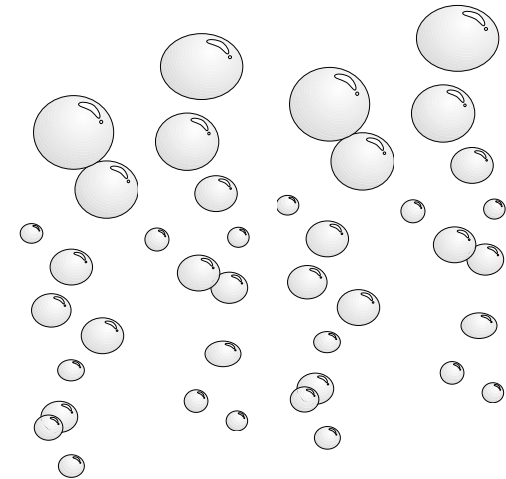

## Jesus Prayed

The children will learn that Jesus prayed and that he taught his disciples to pray.

### Bible Story Text

Luke 11:1-4

### Materials

*For the teacher:*

- Bible
- felt board
- tape
- pictures from the Unit 14 Lesson 3, Bible Story

### Preparation

Place rolled tape on the back of each picture.

### How to Pray

*When we want to talk to God what can we do? Yes, we can pray. Does God like it when we talk to him? Can you show me what you do when you pray? (kneel, close eyes, fold hands, etc.) Do you think Jesus knew how to pray?*

Open the Bible. *The Bible says that one day Jesus was praying (Luke 11:1a). Place the picture of Jesus praying on the felt board.*

*The disciples watched him pray. Place the picture of the disciples on the felt board. They saw how much Jesus loved God, and how he told God what was in his heart when he prayed. They said, Wow! We want to pray like Jesus. Look surprised and impressed. They asked him, Jesus, will you teach us how to pray? (Luke 11:1b).*

*Then Jesus said to the disciples, When you pray say: We love you, God, you are so incredible! You always hear us when we talk to you! (Luke 11:2). Can you say "incredible"? That's right! God is incredible!*

*Then he said to pray for the church, so we can love each other. Can you say, "Thank you for the church"? Can you say, "Love each other"? Let's all give each other a hug!*

*Then Jesus said, Thank you, God, for giving us everything we need every day, like our homes and our families (Luke 11:3). Give two children the pictures of a home and a family to hold up.*

# I Love to Pray

## Prayer Lesson 4

*Thank you, God, for our food that you give us. Give a child the picture of food. Father, thank you, for the clothes that you give us to wear (Luke 11:3). Give a child the picture of clothes.*

*Then Jesus taught the disciples to say they were sorry when they did something that was wrong, and to ask God to forgive them (Luke 11:4).*

### Conclusion

*We all need someone like Jesus to teach us how to pray. What did Jesus teach his disciples to do? Yes, he taught them how to pray.*

*There are so many things that we can talk to God about. Who wants to talk to God? What do you want to say? Let each child pray who wants to say something.*

*Do you ever do anything that is not right? Do you ever have to ask your Mommy and God to forgive you? Let's pray about that. Dear God, thank you for forgiving us when we do things that are not right. Thank you for wanting us to talk to you about everything.*



## Prayers to God

The children will make a bubble to remind them that, just as bubbles go up into the air, their prayers go up to God.

### Materials

*For each child:*

- 2 paper plates
- crayons

*For the teacher:*

- scissors
- clear tape
- plastic wrap
- yarn
- measuring tape or ruler
- hole punch
- stapler
- bubbles

*Reproducible Pages:*

- Page C, 1 copy for each child

### Preparation

1. Prepare the "cutout plates" as follows:
  - A. Cut out a 4" circle from the center of half of the paper plates.  
NOTE: Set aside the other plates for Step 2.
  - B. Cut a 5" square of plastic wrap for each child.
  - C. Tape the plastic wrap on the inside of each cut paper plate covering the hole. See Figure A.
2. Prepare the "whole plates" as follows:
  - A. Cut out the text boxes from the copies of Reproducible Page C.
  - B. Tape the text boxes to the centers of the whole paper plates.
3. Cut one 30" piece of yarn for each child.
4. Make a model of the craft following the instructions.

# I Love to Pray

## Prayer Lesson 4

### Instructions

1. Show the children your model and read the words on the craft to them. *This is a big bubble for you to wear. This will remind you that our prayers go up to God like bubbles!*
2. Give each child a whole plate and some crayons. Have the children color their plates, inside and out.
3. Give each child a cutout plate. Have the children color the outside of their plates.
4. Help each child to put their two plates together face-to-face. Staple the plates together making a "bubble."
5. Punch a hole through the top of each child's bubble.
6. Help each child to thread their yarn through the hole, and then tie the ends into a knot.

### Conclusion

Blow bubbles with the children and talk about how our prayers go up to God just as bubbles go up to the sky.

### Teacher Tips

- Place tape over the staples to cover any rough edges.
- Use tape to connect the ends of the yarn to form a necklace, rather than tying the ends together.
- Use a glue glitter pen to further decorate the plates.

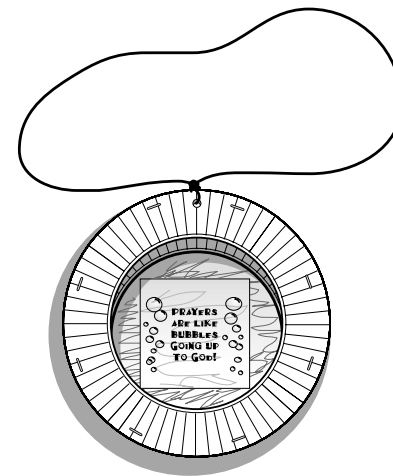

# Craft

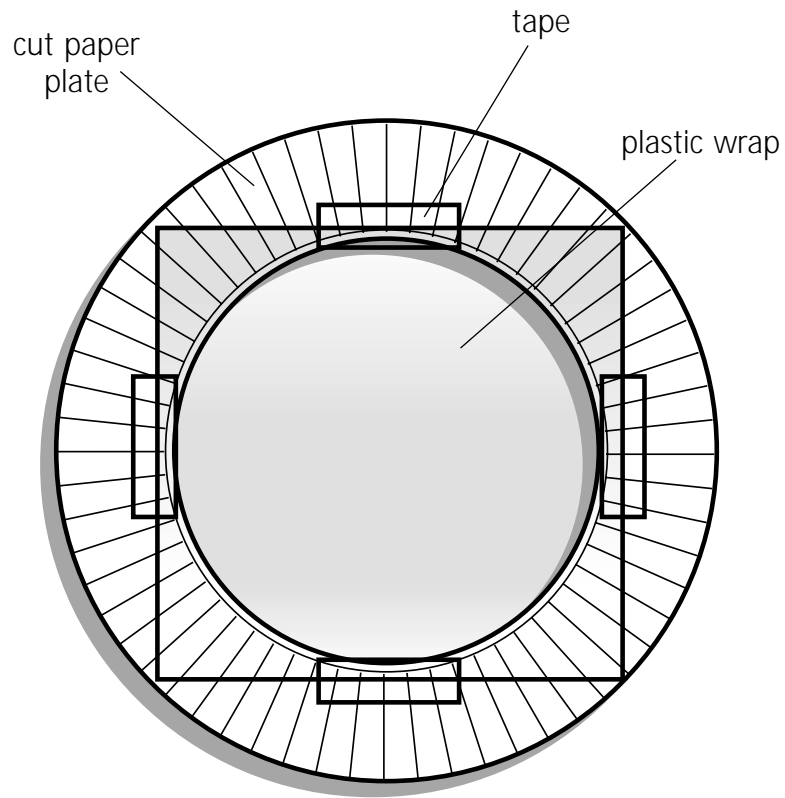
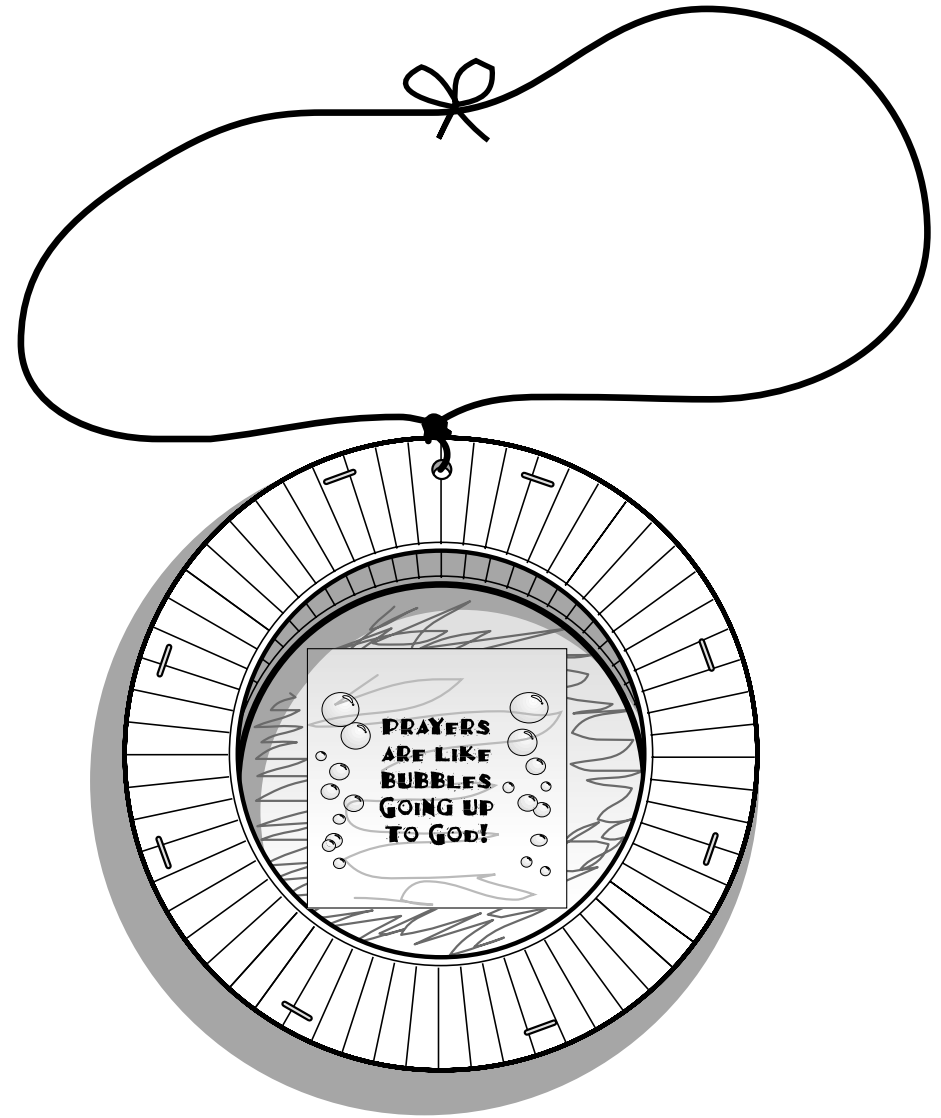

Figure A



Finished Craft





R  
e  
p  
r  
o  
d  
u  
c  
i  
b  
l  
e

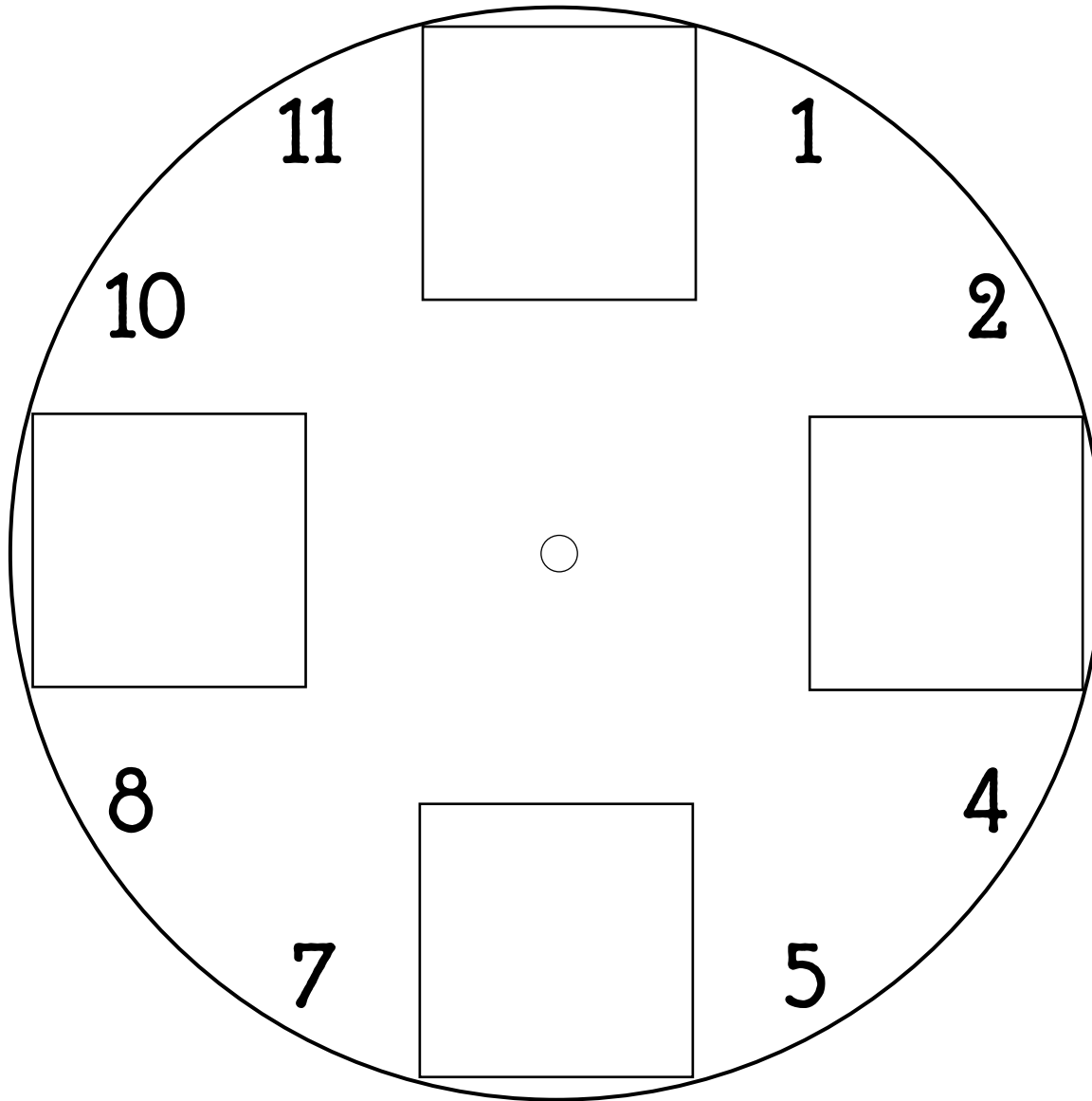

clock

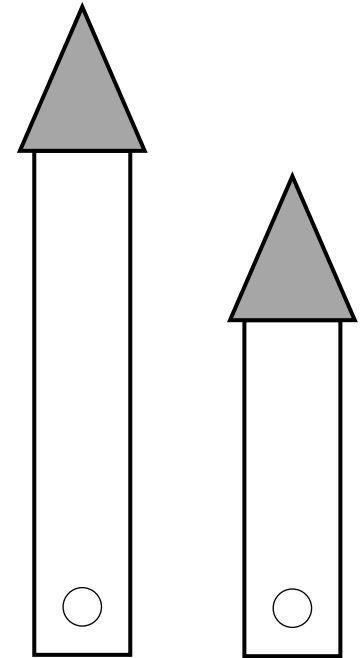

hand stencils





R  
e  
p  
r  
o  
d  
u  
c  
t  
i  
o  
n  
s

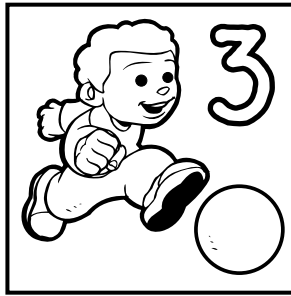





R  
e  
p  
r  
o  
d  
u  
c  
t  
i  
o  
n  
s

