

Leaders Care For Us

Lesson Objectives

- The children will name leaders in their church.
- The children will state that the leaders in Acts helped the widows in the church.
- The children will help those who are in need around them.

Lesson Text

Acts 6:1-5

Scripture Memory Verse

Remember your leaders, imitate their faith.

Hebrews 13:7

Lesson Plan

Greeting and Registration

Preclass Activity: God's Army

Welcome and Singing

Centers:

Bible Story: Leaders Teach Us

Life Application: A Helping Hand

Craft: Serving Apron

NOTE: Be sure to allow sufficient time for a snack.

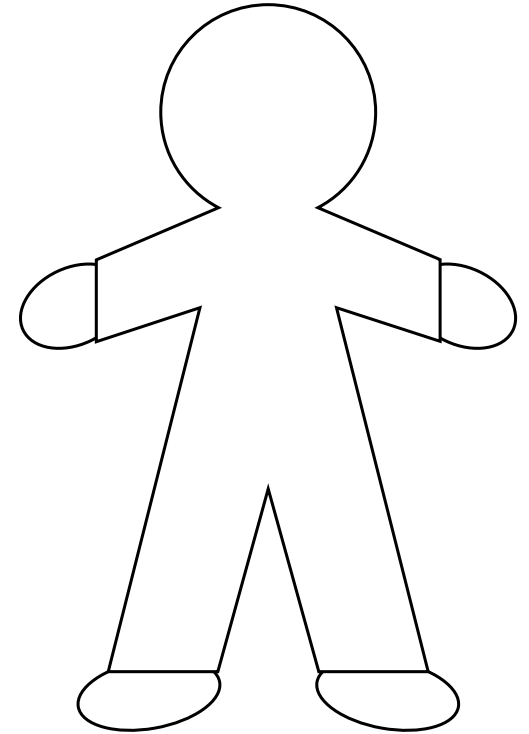

Leaders Care for Us

God's Army

This activity will encourage the children to think about being a follower in God's army.

Materials

For each child:

- glue stick
- crayons or markers

For the teacher:

- 1 large piece of poster board, 16" x 20"
- blue construction paper, several pieces
- gray construction paper, 1 piece
- scissors
- marker

Reproducible Pages:

- Page A, 1 copy for the teacher

Preparation

1. Cut out the stencils from the copy of Reproducible Page A.
2. Trace and cut out the following figures:
 - A. Trace and cut out one child figure from blue construction paper for each child.
 - B. Trace and cut out three leader figures from blue construction paper.
 - C. Trace and cut out one helmet for each child from gray construction paper.
3. Glue the three leader figures onto one side of the poster board.

Instructions

1. Give each child a child figure to color.
2. Have each child glue a helmet onto the figure.
3. Have the children put their names on the front of their figures.
4. Have the children glue their figures next to one another on the poster board. Be sure their names can be read.
5. Give the poster board to the Bible story teacher.

Conclusion

Explain to the children that the church is like God's army. We are all soldiers in God's army. Just like in the military army, God has given us leaders to follow. Our leaders help to take care of us.

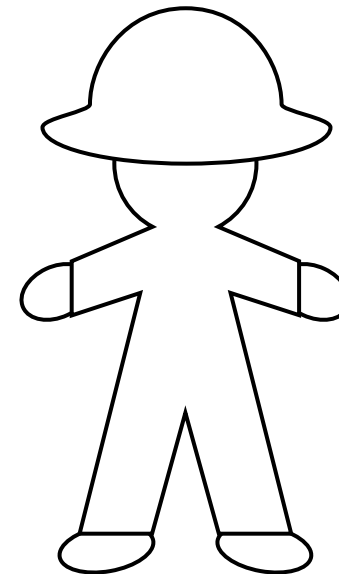

Leaders Care for Us

Leaders Teach Us

The children will learn that God gives us leaders. We are also leaders to the people around us.

Lesson Text

Acts 6:1-5

Materials

For the teacher:

- poster board from the Preclass Activity
- brown construction paper, 1 piece
- black construction paper, 1 piece
- scissors
- marker

Reproducible Pages:

- Page B, 1 copy for the teacher

Preparation

1. Cut out the bread and Bible stencils from the copy of Reproducible Page B.
2. Trace and cut out one loaf of bread for each child from brown construction paper.
3. Trace and cut out one Bible for each child from black construction paper.

Instructions

We have been learning that God gives us leaders. The Bible story in Acts 6 is about how some of the people were not getting any food. Do you remember who the hungry people were? (widows) So the leaders appointed some more leaders to help make sure that everyone got food. We have many different kinds of leaders in our church. (Talk about different roles of leaders; evangelists – teach the Bible, help people spiritually; teen leaders – help the teens to be close to God; administrators – help the money to be spent the right way; children’s ministry leaders – help the children to learn.)

Show the children the poster that they made in the Preclass Activity. *This is a picture of you and some leaders. Why do you have helmets on? Because you are soldiers. You are part of God’s army! Wow! That’s a powerful army to be a part of. It looks like you have some very strong leaders. These leaders don’t have any names on them. What are the leaders’ names in our church? (Help the children with the leaders’ names and write them on the figures on the poster board.)*

What are some things that leaders help us do? Take responses. What happened in Acts when the widows were hungry? Yes, the leaders made sure they got food and that they were taken care of.

If you saw someone who needed food what would you do? Yes, you would give them some food just like the leaders did. Give each child a loaf of bread to glue onto one hand of their figure.

What if you saw that one of your friends needed to know about God? What would you do? Yes, you could give them a Bible and teach them about God. Give each child a paper Bible to glue onto the other hand of their figure.

By helping people around you who have needs, you’re being a leader too. That makes God very happy. He wants us to learn from our leaders and do what they do. Everyone in God’s army should lead by helping the people around them.

Conclusion

Let’s pray for our leaders. They need us to pray for them so that they can be strong and help God’s church. Say a prayer for the leaders in your church.

Teacher Tips

- Be sure to talk about the leaders in your congregation so the children can become familiar with them.

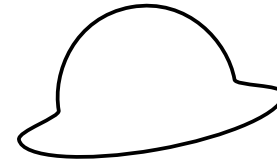

Leaders Care for Us

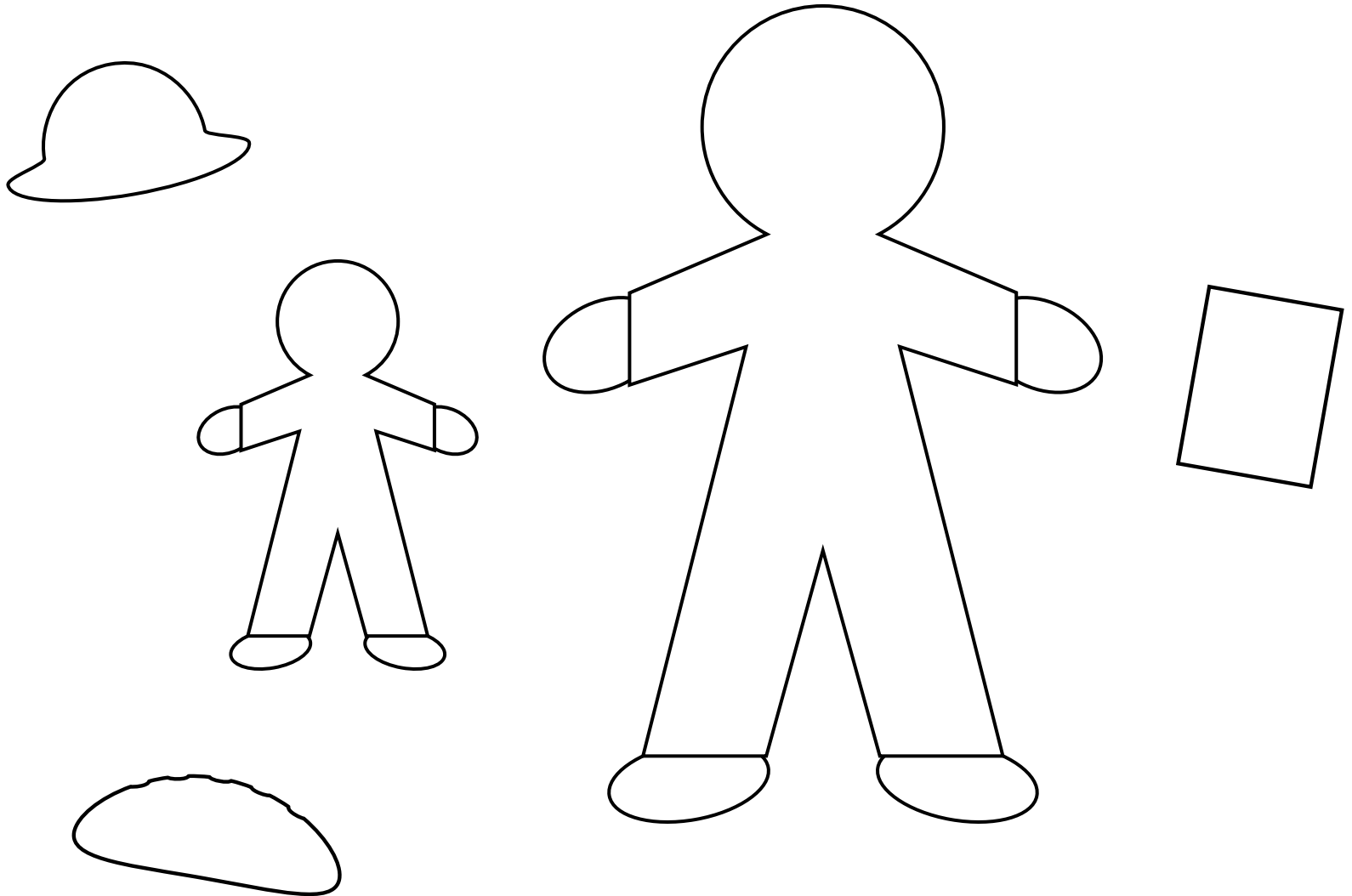



A Helping Hand

The children will choose people to help.

Scripture Memory Verse

Remember your leaders, imitate their faith.

Hebrews 13:7

Materials

For each child:

- crayons

For the teacher:

- construction paper
- scissors
- marker
- stickers to decorate card (optional)

Reproducible Pages

- Page C, 1 copy for the teacher

Preparation

1. Cut out the hand stencil from the copy of Reproducible Page C.
2. Trace and cut out one hand for each child from construction paper.
3. Write on each hand the following, see Figure A:
 - A. Across the side of the hand write "A Helping Hand."
 - B. Along the bottom of the hand write "Helper" with a line after it.
 - C. Below "Helper" write "To" with a line after it.
 - D. Below "To" write "Do" with two lines after it.
4. Make a model following the instructions.

Instructions

1. Remind the children that they are learning about leaders serving us and about us serving each other. Show them the model and explain whom you have chosen to serve and how you are going to serve them.

2. Ask the children to name different ways they can help someone they know (e.g., carrying bags from the store, putting groceries away, helping to set the table, helping to serve snacks, helping to clear the table, calling someone who is sick, helping a teacher pass out papers).
3. Ask each child to think of one person that they would like to help (e.g., Mom, Dad, brother, sister, teacher, or a friend).
4. Give each child a "hand" and have them color the side with no writing on it.
5. As they are coloring, have each child fill in their name next to the word "Helper."
6. Ask each child who they would like to serve and how they will serve them. Write their responses next to the words "To" and "Do."

Scripture Memory Activity

Our leaders help us to meet our needs and they teach us to help one another.

Ask a child to recite the memory verse. Ask the other children if he got the verse right. If not, have another child give him a hint. Have the group continue to help the child until he gets it right.

Encourage the group for working together and helping each other.

Conclusion

Choose a child to say a prayer and thank God for giving us leaders.

Explain to the children that their teachers at school and their child care providers are leaders that God has given them. They can invite these people to come to church with them.

Teacher Tips

- Be prepared to give the children suggestions of how they can serve someone.

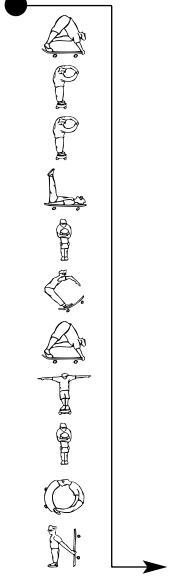

Leaders Care for Us

A Helping Hand

Helper _____

To _____

Do _____

Figure A



Leaders Care for Us

Serving Apron

The children will make aprons reminding them that they should serve and help others.

Materials

For each child:

- 1 large brown paper bag
- crayons or markers
- glue stick

For the teacher:

- scissors
- hole punch
- yarn or string
- other decorative materials (optional)

Reproducible Pages:

- Page D, 1 copy for every 2 children

Preparation

1. Cut out the signs from the copies of Reproducible Page D.
2. Prepare a paper bag for each child as follows:
 - A. Cut off the bottom of the bag, as shown in Figure A.
 - B. Cut a slit along the back of the paper bag. The back usually has a vertical seam. See Figure B.
3. Prepare an apron for each child, see Figure C, as follows:
 - A. Place the bag flat on the work surface.
 - B. Trace and cut an apron shape from the bag.
 - C. Punch four holes in the "apron."
4. Cut four, 12" pieces of yarn for each child.
5. Tie each piece of yarn to the punched holes in the aprons.
6. Make a model of the craft following the instructions.

Instructions

1. Introduce the craft as follows: Explain that leaders serve and help others, and that we should serve and help others, too! Show the children your model. Explain that an apron covers your clothes when you work so that you don't get dirty. You can wear it while you're making food, painting a picture or making a craft.
2. Give each child an apron. Have the children color the apron.
3. Trace each child's hands on the front of their apron with a crayon.
4. Give each child a sign to glue onto their apron above their traced hands.

Conclusion

Have the children share different ways that they can serve using their aprons.

Teacher Tips

- Bring in other decorative materials for the children to glue on their aprons such as fabric, stickers, ribbon, glitter, etc.
- Place hole reinforcements over the punched holes to make the apron last longer.

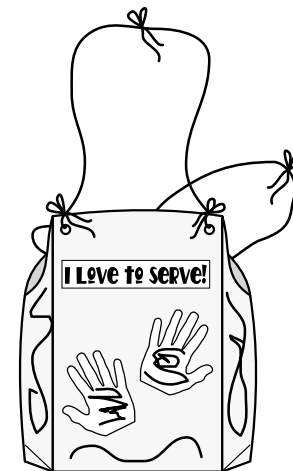

Leaders Care For Us

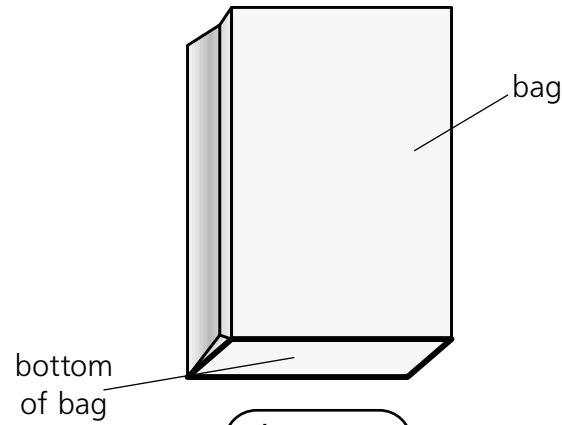

Figure A

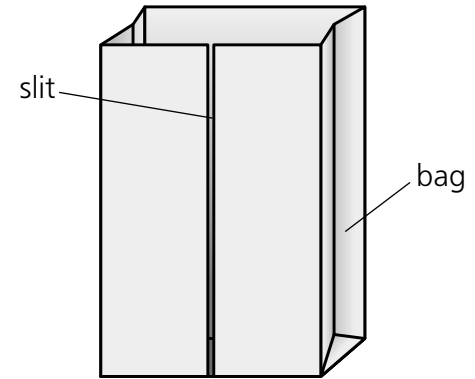

Figure B

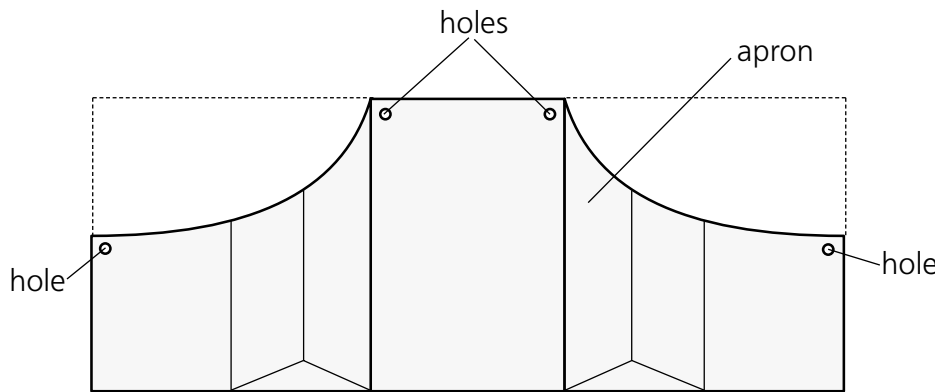
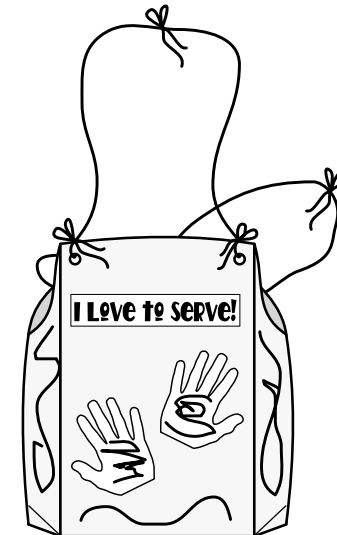

Figure C



Finished Craft





Pre class



Lesson Objectives

- The children will name leaders in their church.
- The children will state that the leaders in Acts helped the widows in the church.
- The children will help those who are in need around them.

Lesson Text

Acts 6:1-5

Scripture Memory Verse

Remember your leaders, imitate their faith.

Hebrews 13:7

Lesson Plan

Greeting and Registration

Preclass Activity: Giving Hands

Welcome and Singing

Centers:

Game: Serve One Another

Craft: We Care

Life Application: A Helping Hand

NOTE: Be sure to allow sufficient time for a snack.

Giving Hands

The children will practice being giving.

Materials

For the teacher:

- box from the craft teacher
- canned goods from your home
- small table
- play cash register
- play money
- marker
- glue or tape
- poster board

Preparation

1. Make a sign out of the poster board that says "The Sharing Store."
2. Before the children arrive set up the store area with the table, cash register, food, sign and box.

Instructions

1. Explain to the children that they are going to play store. But that the things they are going to buy won't be for them but for people in need. Remind them of the Bible story where the leaders in the book of Acts took care of the needs of the widows.
2. Have the children come to your store and buy things to give to the needy.
3. Choose different children to be the cashier and the shoppers.
4. Talk with the children about what kinds of food they can make with the things that they buy.
5. Have the children put the food in the box.
6. Give the box back to the craft teacher.

Teacher Tips

- If you don't have play money or a play cash register they can be made with paper and a small box.
- Have the children help you make play money.

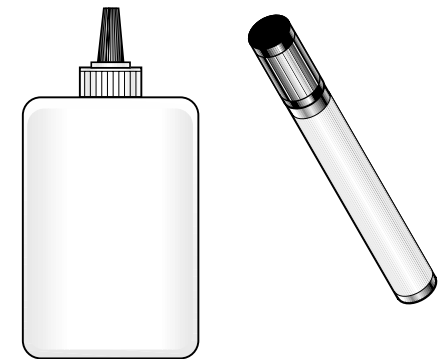



Serve One Another

The children will listen to the leader and imitate their actions.

Materials

For the teacher:

- a piece of paper
- pen



Preparation

1. Learn the tune for "This Is the Way We Wash Our Clothes" and make a list of motions for the children to imitate. Here are some suggestions:
 - This is the way we pick up toys
 - This is the way we set the table
 - This is the way we rake the leaves
 - This is the way we call a friend
 - This is the way we send a card
 - This is the way we pray each day
 - This is the way we obey mom



Instructions

1. Have the children stand in a circle with enough room between them to allow for some movement.
2. Remind the children that they are learning about following their leaders. Tell them that following leaders also means imitating them, by doing what they do.
3. Explain that you are going to sing a song and do some motions and that the children are to imitate you.
4. Sing the first line of the song and do the motion that you choose.
5. Continue with more motions from the list that you made.
6. As the children catch on to the idea, ask for a volunteer to lead with their own idea.

Teacher Tips

- Bring in any props that will go along with your ideas. The children can pass one prop at a time around the circle as they sing.

CRAFT



Leaders Care For Us

We Care

The children will prepare boxes to be used to collect items for needy families in their area.

Materials

For each child:

- glue stick
- 1 box, copier paper size
- crayons

For the teacher:

- Bible
- black marker
- wrapping paper
- magazine with pictures of food, people, toys and clothing
- scissors
- stickers
- other decorative items (optional)

Reproducible Pages:

- Page E, 1 copy for each child
- Page F, 1 copy for each child

Preparation

1. Cut out the signs from the copies of Reproducible Page E.
2. Cut out ten magazine pictures for each child.
3. Cut the wrapping paper into small squares. Cut ten squares for each child.
4. Prepare the parent letters as follows:
 - A. Cut out the parent letters from the copies of Reproducible Page F.
 - B. Investigate and make a list of the names of different organizations in your area that would accept donated items for needy families, e.g., soup kitchens, food pantries, homeless shelters, etc.
 - C. Write down the names of the organizations in the appropriate column on the parent letters.
 - D. Make a model box following the instructions. NOTE: The Preclass Activity teacher will need to use this box.

Instructions

1. Remind the children of the biblical account in Acts 6 where the leaders helped the widows who weren't getting enough food. Explain that there are people today who need food or clothing. *Today we will make a box so that we can collect food, clothing or extra toys to give to people who need them.* Show the children the canned goods from the Preclass Activity.
2. Have the children decorate the outsides of their boxes as follows:
 - A. Have the children glue the wrapping paper squares and the magazine pictures to their boxes.
 - B. Give each child a sign and have them glue it to the side of the box.
 - C. Have the children color their boxes with crayons.
3. Read the parent letter to the children, and then give each child a copy of the letter to put inside their boxes.
4. Help the children write their names on their boxes.

Conclusion

Talk with the children about how people are going to be very happy when they receive this box full of things that they need. Ask the children how they would feel if someone gave them food when they had none.

Remind the children that they are being leaders by helping people.

Teacher Tips

- Choose other decorative items that the children can glue on their boxes.



supplement

CRAFT

Leaders Care For Us

The Church

Lesson 5



Finished Craft



Fall 2

© 1999 by Discipleship Publications International

The Church 10-5-12



A Helping Hand

The children will choose people they can help.

Scripture Memory Verse

Remember your leaders, imitate their faith.
Hebrews 13:7

Materials

For each child:

- crayons

For the teacher:

- construction paper
- scissors
- marker
- stickers to decorate card (optional)

Reproducible Pages

- Page C, 1 copy for the teacher

Preparation

1. Cut out the hand stencil from the copy of Reproducible Page C.
2. Trace and cut out one hand for each child from construction paper.
3. Write on each hand the following, see Figure A:
 - A. Across the side of the hand write "A Helping Hand."
 - B. Along the bottom of the hand write "Helper" with a line after it.
 - C. Below "Helper" write "To" with a line after it.
 - D. Below "To" write "Do" with two lines after it.
4. Make a model following the instructions.

Instructions

1. Remind the children that they are learning about leaders serving us and about us serving each other. Show them the model and explain whom you have chosen to serve and how you are going to serve them.

2. Ask the children to name different ways they can help someone they know (e.g., carrying bags from the store, putting groceries away, helping to set the table, helping to serve snacks, helping to clear the table, calling someone who is sick, helping a teacher pass out papers).
3. Ask each child to think of one person that they would like to help (e.g., Mom, Dad, brother, sister, teacher, or a friend).
4. Give each child a "hand" and have them color the side with no writing on it.
5. As they are coloring, have each child fill in their name next to the word "Helper."
6. Ask each child who they would like to serve and how they will serve them. Write their responses next to the words "To" and "Do."

Scripture Memory Activity

Our leaders help us to meet our needs and they teach us to help each other.

Ask a child to recite the memory verse. Ask the other children if he got the verse right. If not, have another child give him a hint. Have the group continue to help the child until he gets it right.

Encourage the group for working together and helping each other.

Conclusion

Choose a child to say a prayer and thank God for giving us leaders.

Explain to the children that their teachers at school and their child care providers are leaders that God has given them. They can invite these people to come to church with them.

Teacher Tips

- Be prepared to give the children suggestions how they can serve someone.



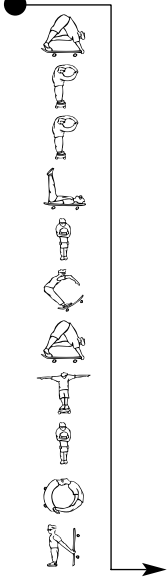
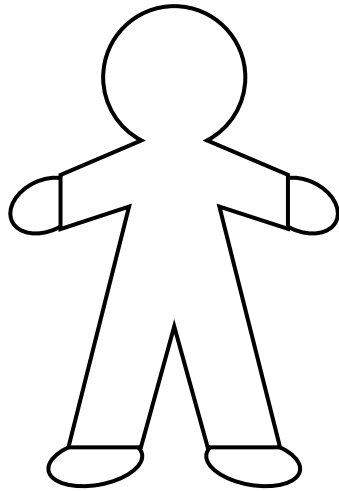

Figure A



Core/Preclass Activity
1 copy for the teacher

The Church
Lesson 5



child stencil

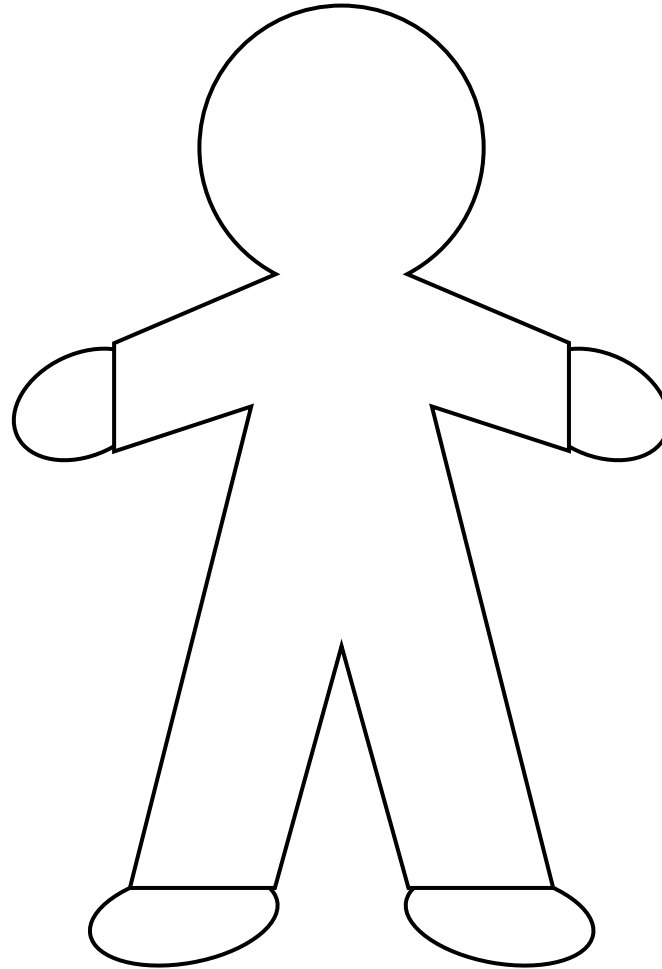

leader stencil

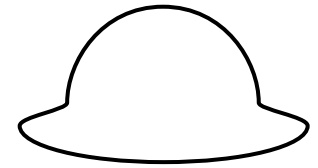

helmet stencil

Core/Bible Story

1 copy for the teacher

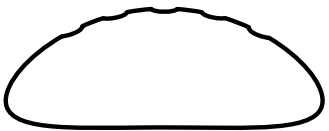
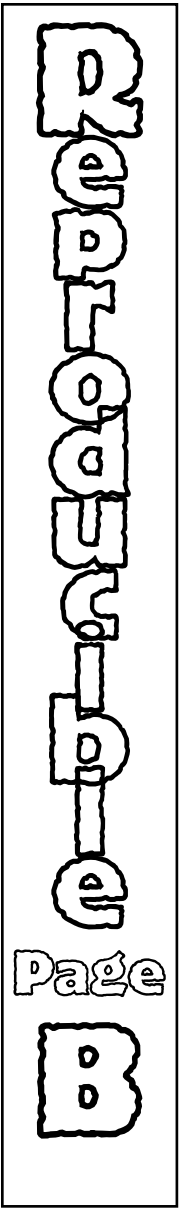

bread stencil

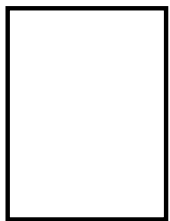

Bible stencil



Core and Supplement/Life Application
1 copy for the teacher

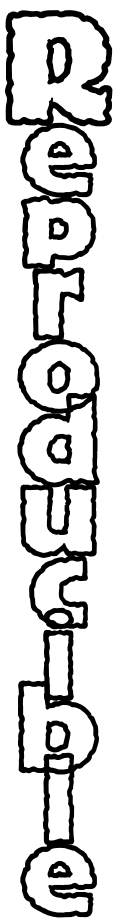

 Page



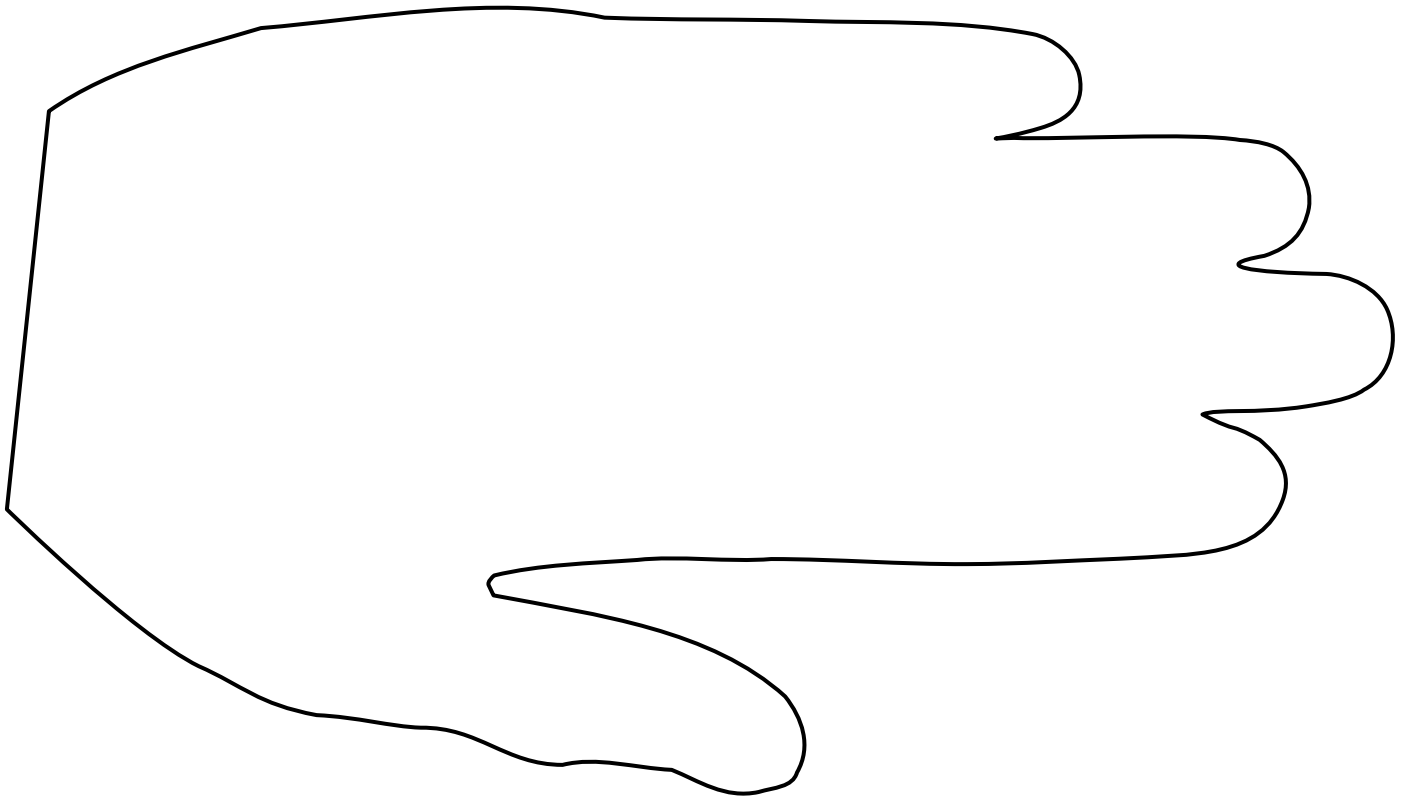

hand stencil



Core/Craft

1 copy for every two children

Discipleship

Page

D

I Love to serve!

I Love to serve!

signs



Supplement/Craft

1 copy for each child

Preparation

Page

5

**MY
Family
CARES**



Supplement/Craft

1 copy for each child

Page
F



Dear Parent,

The children in our class are learning about sharing what they have with people who are in need. Your child has decorated this box in hope that you, as a family, can fill it with things that a needy family might be able to use.

Below is a list of recommended items and a list of organizations in the area that would welcome such donations.

Recommended Items

- foods: canned foods, pasta
- nonfood items: toilet paper, toothpaste, diapers
- clothing
- toys

Recommended Organizations

Thank you for your help and concern for those who are in need,

Your child's teachers

