

Ezra and Nehemiah

Lesson Objectives

- The students will state that the temple and the wall of Jerusalem were restored.
- The students will describe one way that Nehemiah helped the people reach their goals.
- The students will identify one way that they can overcome discouragement.

Lesson Text

Ezra 1-10
Nehemiah 1-13

Scripture Memory Verse

Perseverance must finish its work so that you may be mature and complete, not lacking anything.

James 1:4

Lesson Plan

Greeting and Registration

Preclass Activity: Jerusalem Jumble

Welcome and Singing

Centers:

Bible Story: Building Up the Kingdom

Craft: On the Wall

Scripture Memory: Finish the Work

NOTE: Allow time for a snack

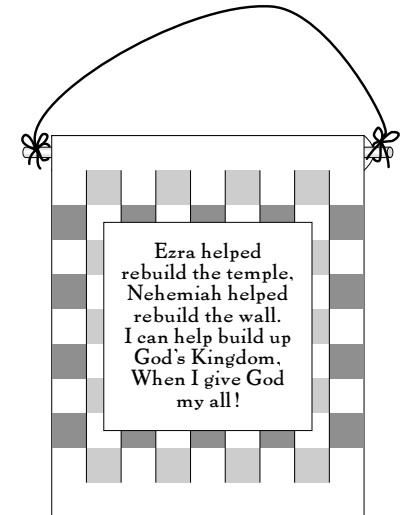

P
R
E
•
C
L
A
S
S

Ezra and Nehemiah

Jerusalem Jumble

The students will preview this week's lesson as they complete this word scramble.

Materials

For each student:

- pencil
- colored construction paper, 9" x 12"
- scissors
- ruler

Reproducible Pages:

- Page A, 1 copy for each student

Preparation

Complete the activity on your copy of Reproducible Page A.

Instructions

1. Greet the students as they arrive. Tell them that in today's lesson they are going to learn about two men who helped to rebuild and restore God's temple and Jerusalem's wall. Explain that this activity will introduce them to key words and ideas in this week's lesson.
2. Distribute the copies of Reproducible Page A and the pencils.
3. Encourage the students to work together and to use their Bibles.
4. Circulate among the students to offer help.
5. For students who finish early, give them scissors, construction paper and rulers. Have them cut out one inch strips (1" x 9") to be used later for the craft. Show them an example of how to do it. (You can prepare the strips for cutting by drawing lines one inch apart on the construction paper.)

Teacher Tips

- Visit your library to obtain pictures of ancient Jerusalem and the temple, as well as pictures of the city today. Display these pictures for the students to see.
- Invite disciples who have visited Jerusalem to come and talk to the students about their visit.

Jerusalem Jumble

The following words are very important to today's lesson.
Can you figure them out? If you need help, look up the verse that contains the word.

ZARE (EZRA 7:1)	<u>EZRA</u>	NEEMHAIH (NEHEMIAH 1:1)	<u>NEHEMIAH</u>
SURCY (EZRA 1:1)	<u>CYRUS</u>	INNAAH (NEHEMIAH 1:2)	<u>HANANI</u>
SERPJA (EZRA 1:1)	<u>PERSIA</u>	MENRANT (NEHEMIAH 1:2)	<u>REMNANT</u>
BLUID (EZRA 1:2)	<u>BUILD</u>	LEXIE (NEHEMIAH 1:3)	<u>EXILE</u>
PETLEM (EZRA 1:2)	<u>TEMPLE</u>	MELASUREJ (NEHEMIAH 1:3)	<u>JERUSALEM</u>
RUSVIVROS (EZRA 1:4)	<u>SURVIVORS</u>	GRACEDIS (NEHEMIAH 1:3)	<u>DISGRACE</u>
TIVITPACY (EZRA 9:7)	<u>CAPTIVITY</u>	AARRXXEETS (NEHEMIAH 2:1)	<u>ARTAXERXES</u>

Ezra and Nehemiah

Building Up the Kingdom

The students will learn about two faithful men who helped rebuild God's temple and Jerusalem's wall.

Materials

For the teacher:

- pictures of a city in ruins (from natural disaster or war)
- 1 piece of parchment paper
- 1 piece of ribbon
- 1 pair of glasses
- 1 toy sword

NOTE: If parchment paper is not available, use brown or tan paper instead.

Preparation

1. Roll the piece of parchment paper and tie it with ribbon. This will be Ezra's "scroll" in the Bible Story.
2. Practice introducing and leading this activity with the props and with great enthusiasm.

Introducing the Bible Story

Open your Bible to the books of Ezra and Nehemiah. Show the students that these two books are just before Esther, the book they learned about last week. Explain that the events of today's lesson will conclude this unit about the exile and return from captivity.

Ask the students to close their eyes and try to imagine the following situation: *You are on your way home from school when suddenly you see some soldiers outside your house. These are not regular soldiers. They look different and they speak a different language. They seem angry at your parents. They want all of you to get into their truck. They are going to take you away to their country. Your mother sees you and calls for you to come quickly. You are all together in a dark space being taken off to a strange place. You don't know how long you will be gone or when you will return.*

Tell the students to open their eyes. Ask them what they might feel in this situation. Explain that what you just described actually happened to the people of Israel and Judah. Because of their sins, the people were taken captive—prisoners—by foreign kings. The king of Assyria and the king of Babylon were kings who took God's people into captivity for many years. This was also called the "exile" of

God's people. In fact, many of the people taken captive died and it was their children who were finally released years later. Pass around the disaster pictures for them to see and ask the students the following questions:

- *How would you feel if you were released from captivity and returned to your home years later to find it completely destroyed?*
- *How would you feel if you returned to your neighborhood only to find out that all of your neighbors had been carried off to different places?*
- *How would you feel if you had been in exile or separated from your own family and best friends for many years?*

Help the students to understand that this is what really happened to the Israelites. They were taken captive, separated from friends and family, and later returned to find their city and temple in ruins. Explain that in this story, they will learn about two men who were determined to help them rebuild their temple and city so they could give glory to God once again.

God's Power Tools

Tell the students that you will show them three "tools" that Ezra and Nehemiah used to help rebuild God's city. Hold up the scroll and explain that it stands for the word of God that Ezra brought. *Ezra was a scribe and a priest. His ancestor was Aaron, Moses' brother. He was sent by his king to Jerusalem to help the people who were there. After Cyrus king of Persia let the first captives return to Jerusalem, they started to rebuild the temple. Then their enemies forced them to stop their work. Ezra came to help them get started again. He brought supplies and riches for the Lord's temple, and he brought wisdom and knowledge of God's law to teach the people how to love and worship God again.*

Ask the students what they think would happen if they were taken to a place that didn't have any Bible for a long time. *What would happen if people wanted to serve God but did not know how? Why is the Bible an important tool to help up love and worship God? Why do we need people to teach us?*

Nehemiah was a Hebrew who had been taken captive into Babylon. He was the cup-bearer to the king, which meant that the



3rd and 4th Grades

Ezra and Nehemiah

king trusted him with his life. (If someone tried to poison the king, the cupbearer would find out first!)

Nehemiah learned from a close friend named Hanani that Jerusalem and its walls were in ruin and disgrace. He cried out to God and prayed. Then he went to the king who agreed to send him back to help his brothers rebuild Jerusalem.

Take out the glasses. Tell the students to listen as you read the Bible and think about how Nehemiah used his eyes as a tool for God:

I went to Jerusalem, and after staying there three days I set out during the night with a few men. I had not told anyone what my God had put in my heart to do for Jerusalem. There were no mounts with me except the one I was riding on.

By night I went out through the Valley Gate toward the Jackal Well and the Dung Gate, examining the walls of Jerusalem, which had been broken down, and its gates, which had been destroyed by fire. Then I moved on toward the Fountain Gate and the King's Pool, but there was not enough room for my mount to get through; so I went up the valley by night, examining the wall. Finally, I turned back and reentered through the Valley Gate. (Nehemiah 2:11-15)

Nehemiah used his eyes to see the needs, and then he helped the people to see what they could do to help. He put entire families together along the wall to do the work. He helped the people stay focused on their special jobs as everyone worked together.

Take out the sword. *There were many enemies who tried to stop their work. People threatened them, made fun of them and promised to kill them. Not only did Nehemiah help the people focus on their work, he helped them focus on God.*

After I looked things over, I stood up and said to the nobles, the officials and the rest of the people, "Don't be afraid of them. Remember the Lord, who is great and awesome, and fight for your brothers, your sons and your daughters, your wives and your homes." (Nehemiah 4:14)

Nehemiah helped the people to remember that God was their power and protection. He used his sword to point them to God. Ultimately the people finished the wall and the enemies of God were put to shame. Briefly review each of the three tools from today's lesson.

Sharing with Others

Do you remember what we imagined at the beginning of our lesson? Can you think of anyone who is feeling sad or discouraged? What do you think God would want you to say to your friend? How would Nehemiah help someone rebuild their faith in God? Close with a prayer for the students to build up God's kingdom the way Nehemiah did.

Teacher Tips

- If you don't have a toy sword, make one by cutting a cardboard strip and wrapping it in aluminum. Write the words "God is our defender" on the sword.
- If your class schedule permits, you may want to blindfold the students for the introduction to Bible Story.

C

R

A

F

T

Ezra and Nehemiah

On the Wall

The students will make a craft to remind them that God helped his people to rebuild the wall of Jerusalem.

Materials

For each student:

- 1 piece of black construction paper, 9" x 12"
- 10 strips of colored construction paper, 1" x 9"
- 1 piece of yarn, 20"
- 1 wooden dowel, 12"
- glue stick
- crayons or markers

For the teacher:

- scissors
- invisible tape

Reproducible Pages:

- Page B, 1 copy for each student

Preparation

1. Make arrangements with the Preclass teacher to have the students help precut the colored construction paper during the Preclass.
2. For each student, prepare the black construction paper as follows: Fold each piece in half, then cut four-inch slits one inch apart beginning at the fold. Leave two inches at the top. See Figure A.
3. Unfold the black paper. At one end, fold down about one inch from the top and tape securely, as shown in Figure B. The dowel rod will be placed through this flap.
4. For each student, cut out the poem from the copies of Reproducible Page B.
5. Make a sample craft to show the students.

Instructions

1. Introduce today's activity: *In today's lesson, you are learning about Ezra and Nehemiah. These two men loved God and helped to rebuild and restore God's temple and the wall of Jerusalem. They both worked very hard and inspired the people to work together and persevere so that the work would be finished. God still wants us to work together and persevere so that his work will continue to be done. In today's activity, you will*

make a special wall hanging. It will remind you of these two men and how God wants you to learn from them today.

2. Show the students your sample craft. Explain that a wall hanging is like a picture and is for decorating a wall. Read the poem on your craft to the students.
3. Distribute the black construction paper that you prepared and the color strips. Show the students how to weave the first strip over, under, over, under, etc. Then have them weave the second strip in the opposite order: under, over, under, over, etc., as shown in Figure C. Have them do this until they have filled their black construction papers.
4. As the students are weaving their papers, circulate among them to insert the wooden dowels in the flaps you prepared. This should be the top of the wall hanging, as shown in Figure D.
5. When the students have finished weaving, distribute their copies of the poem and tell them to glue these onto their papers. They can place it anyway they like.
6. Distribute the yarn and help the students to tie it to both ends of the dowel, making a hanger. See Figure E. If time permits, have the students color or decorate their wall hangings.

Conclusion

Explain that the wall of Jerusalem was not like a wall in their house. It was a huge wall that protected the city. It took a lot of hard work for the people to rebuild it—but they knew that the wall would protect them from their enemies. Encourage the students to hang their crafts in places where they can see them and remember today's story. Close with a prayer for the students to have hearts to help God's people like Nehemiah and Ezra.

Teacher Tips

- Bring in additional decorative items such as glitter or other materials for the students to use.



3rd and 4th Grades

Ezra and Nehemiah

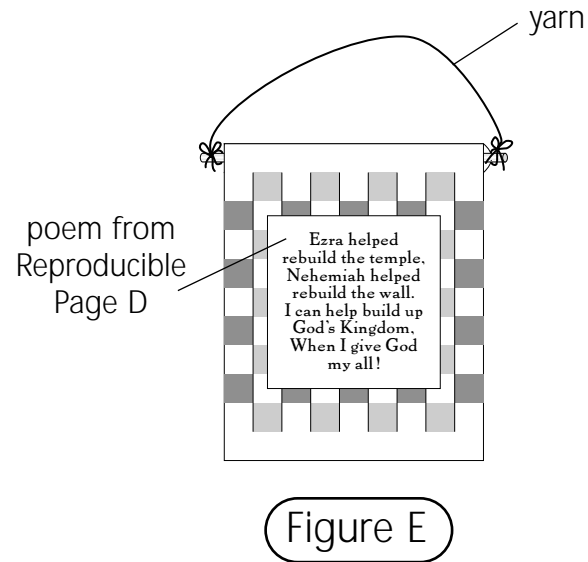
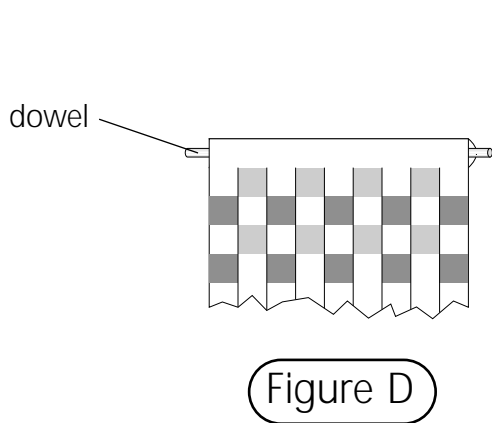
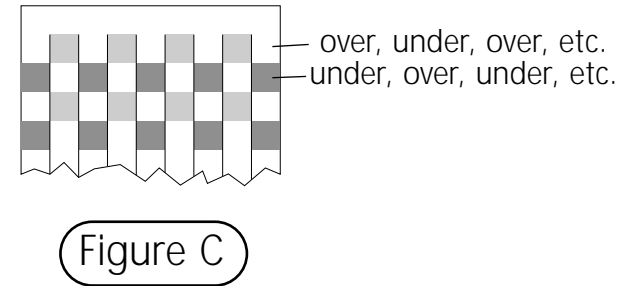
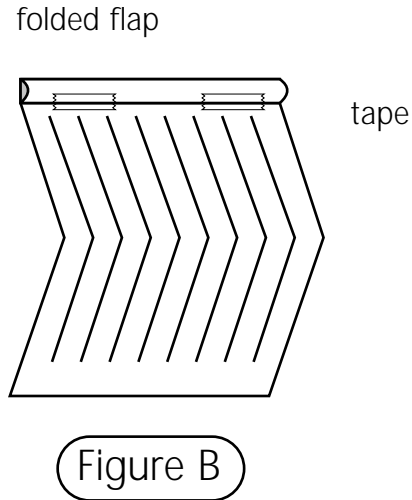
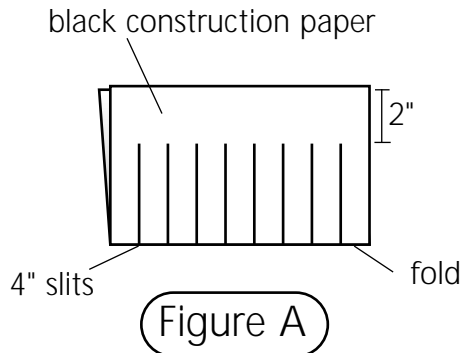

Ezra and Nehemiah

Finish the Work

The students will learn and memorize today's Scripture Memory Verse as they consider the importance of persevering and finishing God's work.

Scripture Memory Verse

Perseverance must finish its work so that you may be mature and complete, not lacking anything.

James 1:4

Materials

For the teacher:

- scissors
- 1 piece of black construction paper, 9" x 12"

Reproducible Pages:

- Page C, 1 copy for the teacher

Preparation

1. Cut out the sixteen word blocks from your copy of Reproducible Page C.
2. Practice leading this activity.

Instructions

1. Introduce today's activity: *In today's lesson, you are learning about Ezra and Nehemiah. These two men loved God and helped to rebuild and restore God's temple and the wall of Jerusalem. They both worked very hard and inspired people to work together and persevere so that the work would be finished. God still wants us to work together and persevere so that his work will be done. In today's activity, you will learn an important verse that teaches us to persevere.*
2. Show the students the Scripture Memory Verse on the back of this Lesson Card. Say it to the students once as they listen. Ask them to say it with you three times. Ask the girls to say it, then ask the boys to say it. Ask for pairs of students to say it together. Ask for volunteers to say it alone.

3. Put the black construction paper flat on a table or floor. Place the words in order onto the black paper. Show the students the sixteen pieces of paper that form today's verse. Point out that the reference is screened behind the words.
4. Distribute the words among the students and have them place them in the correct order.
5. Collect the words, shuffle them and repeat Step 4.
6. Divide the students into two groups. Let each group take turns putting the words in order from memory.
7. Remove one word from the set and have the students tell you what word is missing.

Conclusion

Explain that perseverance means to be determined to finish something no matter what. Tell them that Nehemiah and the people persevered to finish the wall even though they did not sleep, and in spite of their enemies threatening their families. Ask the students to think of something that they have to do even though it is hard at times. Remind them that God uses these situations to make us more complete and able to help others. Close with a prayer for the students to see how perseverance can help them to please God.

Teacher Tips

- Reproducing Page C on heavy paper and laminating will provide a sturdy material for this activity.

Perseverance	must	finish	its
work	so	that	you
may	be	mature	and
complete,	not	lacking	anything.

SC
RI
PT
U
RE
M
E
M
O
R
Y

Perseverance must finish
its work so that you may
be mature and complete,
not lacking anything.

James 1:4

Lesson Objectives

- The students will state that the temple and the wall of Jerusalem were restored.
- The students will describe one way that Nehemiah helped the people reach their goals.
- The students will identify one way that they can overcome discouragement.

Lesson Text

Ezra 1-10
Nehemiah 1-13

Scripture Memory Verse

Perseverance must finish its work so that you may be mature and complete, not lacking anything.

James 1:4

Lesson Plan

Greeting and Registration

Preclass Activity: Wall of Fame

Welcome and Singing

Centers:

Life Application: Willing Volunteers

Game: Wall Hangings

Bible Skills: Sword Drill

NOTE: Allow time for a snack.

Wall of Fame

The students will review this week's lesson as they illustrate a Wall of Fame.

Materials

For each student:

- 1 index card, 3" x 5"
- brightly colored markers

For the teacher:

- 1 piece of banner paper, 5' for each group of five students

Reproducible Pages:

- Page D, 1 copy for each student

Preparation

Begin this activity on one piece of banner paper to show the students.

Instructions

1. Greet the students as they arrive. Tell them that they will be reviewing key words from this week's Bible Story as they build a wall together.
2. Divide students into groups of five as they arrive, and assign them to a piece of banner paper.
3. Distribute the copies of Reproducible Page D, the index cards and markers. Tell the students to use their index cards as their stencil to make bricks in the wall. They will trace their index cards onto the banner paper and then write one word inside each "brick," using the list from their copies of Reproducible Page D. Each student should try to do as many of the words on the list as possible.

4. When the students have finished writing their words on the paper, they can trace bricks in any blank space and decorate them.

Teacher Tips

- Mount the banners where the students and parents can see them.

Willing Volunteers

The students will review this week's Bible Story as they think of ways they can overcome discouragement in their lives.

Materials

For the teacher:

- scroll (roll parchment paper and secure it with a ribbon)
- eyeglasses
- sword

Preparation

1. Practice leading this activity with excitement about what they will be learning.
2. If possible, obtain the Bible Story Lesson Card to review the "Building Up the Kingdom" Core lesson.

Reviewing the Bible Story

Open your Bible to the books of Ezra and Nehemiah. *This week, you learned about Ezra and Nehemiah. These men both spent many years helping God's people to restore Jerusalem which had been left in ruins by the captivity. They helped God's people who had been in exile to worship God again. The people who came back to rebuild the temple and the wall faced a lot of persecution from the enemies of God's people.*

God's enemy is the devil, or Satan. Satan hates God and he also hates God's people. Satan does not want people to worship God or do anything that would make God happy. That is why he is very good at discouragement. He will try to make people do bad things and will arrange situations that discourage God's people. In the lesson this week, you learned about some special and powerful tools that Nehemiah and Ezra used to help the people overcome discouragement and to reach their goals.

Life Application

Hold out the scroll. *Ezra was the priest who came from Babylon to Jerusalem to help the people learn how to worship God again. He was very knowledgeable about God's law. He helped the people overcome their discouraging fears by teaching them how to obey God's laws.*

- *You can use the Bible like Ezra did to help people overcome discouragement. Can you think of someone right now who is discouraged because they don't understand God? (Take responses.)*
Hold out the glasses. *Nehemiah was the cupbearer to the king who left the palace as soon as he heard the terrible condition of Jerusalem. The first thing he did was travel around the city and take a good look at the trouble. He helped the people overcome their discouragement by telling them how the wall could be repaired and showing them how to do the work.*
- *You can use your eyes like Nehemiah did to see the needs of people around you. What are some needs you see right now? (Take responses.)*
Hold out the sword. *Not only did Nehemiah help the people focus on their work, he also helped them overcome their discouragement by looking to God. Nehemiah was always reminding people that God was in charge and would protect them and their families.*
- *You can be like Nehemiah and help people focus on God. Can you think of someone right now who is too discouraged to see what God is doing? (Take responses.)*

Conclusion

Remind the students that God allowed his people to be in captivity so that they would understand how important it is to obey his laws. By bringing them back to Jerusalem, he was giving them another chance to worship him. Ask the students to name one way that they will overcome discouragement this week, as they consider the three tools they learned about today. Close with a prayer for the students to have hearts to build up God's kingdom.

Teacher Tips

- Establish a "no name" rule during discussions. The students should feel free to share about themselves but not to name another student in the group. Talk with the students about how to deal with their situations by using the Bible, godly advice and each other.



3rd and 4th Grades



Wall Hangings

The students will review key concepts from this week's lesson as they play hangman.

Materials

For the teacher:

- large erasable writing surface or pad of paper
- scrap paper
- pencils

Preparation

1. Make sure that you have the appropriate writing surface and instruments for this activity. Use the hangman gallows on the back of this Lesson Card as a model for the one you will be making.
2. Practice playing this game at home.

Instructions

1. Introduce today's activity: *In this week's lesson, you learned about Ezra and Nehemiah. These two men were devoted to God. They both spent many years leading God's people during the rebuilding and restoring of the temple and wall in Jerusalem. These men faced great persecution from the enemies of God's people. At times, Nehemiah had to work all night and all day holding his weapon. Both men give us great examples of perseverance for finishing God's work. In our game today, we will review some important people and events from the Bible Story, as you try and guess the words.*
2. Divide the students into two teams. Make sure that those who did not hear the Bible Story are divided equally among the teams.
3. Show them the hangman "gallows" that you prepared. Underneath, write the same number of spaces as the number of letters in the first word. For example, for "Persia" write six spaces. See Figure A on the back of this Lesson Card. The object of the game is to guess the word before all the parts of the hangman are drawn. For each incorrect letter guessed, you draw one part of the hangman (the head; body; two legs; two arms). If the students have not guessed correctly after the six guesses, then the round is over. Make sure to write each incorrect letter guessed below the hangman so that the students do not repeat the wrong guess. See Figure B.



4. Let the teams take turns guessing a word. If the playing team does not successfully guess their word, then the round is over. The other team may have one chance to guess. If they are correct, they earn one bonus point. A playing team earns three points for each word guessed correctly.
5. After a word has been guessed or revealed, you may ask a bonus question, located on the back of this Lesson Card, to both teams. The teams should write their answers first and then read them to you. Both teams can earn two bonus points for correctly answering a bonus question.
6. Play as many rounds as time permits. Total the points and encourage both teams for their efforts.

Conclusion

Ask the students to say one thing that helped Nehemiah or Ezra to persevere. Encourage the students to think of ways that they can persevere to help their friends or family do the right thing for God. Close with a prayer for the students to love God and want to finish his work.

Teacher Tips

- If you are not familiar with the game of hangman, ask someone to help you.

G
A
M
E

Wall Hangings

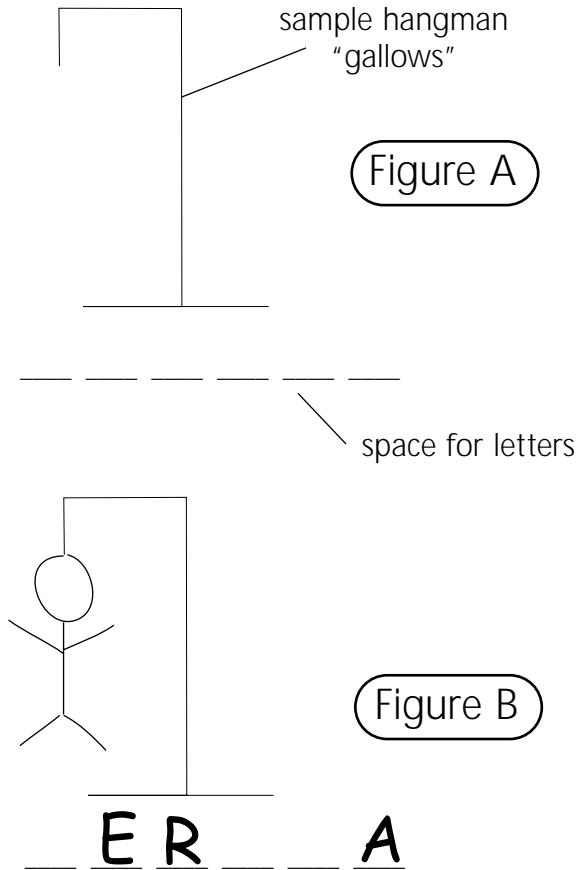

Example: Wrong guesses: l,m,b,c,f,k
(correct answer: Persia)

Word List

Ezra

Nehemiah

Jerusalem

exile

survivors

temple

persevere

rebuild

Bonus Questions & Answers

Who was Ezra?

He helped rebuild the temple and teach people how to worship.

Who was Nehemiah?

He rebuilt the wall of Jerusalem.

What happened to the city of Jerusalem during captivity?

The walls and gates were ruined.

What was the "exile"?

It is when God's people were taken into captivity by foreign kings.

Who were the survivors?

The people who were still living after the captivity.

What happened to the temple during the captivity?

It was in ruins.

What does persevere mean?

Don't give up; finish the work no matter what.

What did God's people need to rebuild?

The temple and the wall



3rd and 4th Grades

Sword Drill

The students will review the books of Esther, Nehemiah and Ezra as they participate in a Sword Drill.

Materials

For the teacher:

- timer or watch with a second hand
- pencil and paper

Preparation

Practice leading this activity with great excitement and enthusiasm.

Instructions

1. Introduce today's activity: *In this week's lesson, you learned about Ezra and Nehemiah. These two men were devoted to God. They both helped lead God's people to rebuild the temple, the city wall and their faith. These men faced great persecution from the enemies of God's people. At times, Nehemiah had to work all night and all day holding his weapon. We can learn about these men and about Esther in the Old Testament books named after them. In today's activity, you will test your skills at finding chapters and verses from these books.*
2. Make sure that each student has a Bible. Have new or visiting students pair up with students who have a Bible and can help them.
3. Have the students sit in a circle. Have them close their Bibles in front of them. Remind them that this is a drill to see how quickly they can locate books, chapters and verses in the Bible. Explain that the focus of this drill will be on the books of Ezra, Nehemiah and Esther.
4. Using the chart on the back of this Lesson Card, do the first one together without timing them. Tell the students that you will prepare them by saying, "Ready" followed by the reference, which you will say twice. Then you will say "Draw Swords" and the students may open their Bibles and look for the reference you have named. A student who needs a reference repeated may raise his hand. A reference may only be repeated once for each student.

5. After a student locates the reference, he should place his finger on it and raise his other hand to signal he is done. Note the time of the first three students to raise their hands. Wait until all the students are finished and have them read the verse together as a group. Have the students close their Bibles before they begin the next round.
6. Do this for each reference on the chart, noting the first three students' times as they finish.

NOTE: For a more challenging version, you may ask the references in a different order than the one provided for you on the back of this Lesson Card. Do this only with students who are confident in their Bible abilities and who will welcome the additional challenge.

Conclusion

Encourage the students for their participation. Remind them that they are now able to find three of the most inspiring books in the Bible quickly and efficiently. Encourage the students to make up a Sword Drill to do with friends, parents, or older brothers and sisters. Close with a prayer for the students to use God's word to build their faith in God.

Teacher Tips

- Consider hosting a tournament Sword Drill in which students will compete in a series of rounds ending with a finalist. Arrange to have the winning and runner-up students recognized.

Sword Drill

Sample exercise:

The students begin with their Bibles closed in front of them.
You say: *Ready. Ezra 1:1. Ezra 1:1. Draw Swords!*
The students open their Bibles and find the scripture reference.

1.	<i>Ready.</i>	<i>Ezra 3:11</i>	<i>Ezra 3:11</i>	<i>Draw Swords!</i>
2.	<i>Ready.</i>	<i>Ezra 4:24</i>	<i>Ezra 4:24</i>	<i>Draw Swords!</i>
3.	<i>Ready.</i>	<i>Ezra 7:6</i>	<i>Ezra 7:6</i>	<i>Draw Swords!</i>
4.	<i>Ready.</i>	<i>Nehemiah 1:3</i>	<i>Nehemiah 1:3</i>	<i>Draw Swords!</i>
5.	<i>Ready.</i>	<i>Nehemiah 2:17</i>	<i>Nehemiah 2:17</i>	<i>Draw Swords!</i>
6.	<i>Ready.</i>	<i>Nehemiah 4:14</i>	<i>Nehemiah 4:14</i>	<i>Draw Swords!</i>
7.	<i>Ready.</i>	<i>Esther 2:18</i>	<i>Esther 2:18</i>	<i>Draw Swords!</i>
8.	<i>Ready.</i>	<i>Esther 4:16</i>	<i>Esther 4:16</i>	<i>Draw Swords!</i>
9.	<i>Ready.</i>	<i>Esther 8:16</i>	<i>Esther 8:16</i>	<i>Draw Swords!</i>



Jerusalem Jumble

The following words are very important to today's lesson.
Can you figure them out? If you need help, look up the verse that contains the word.

ZARE (EZRA 7:1) _____	NEEMHAIH (NEHEMIAH 1:1) _____
SURCY (EZRA 1:1) _____	INNAAH (NEHEMIAH 1:2) _____
SERPIA (EZRA 1:1) _____	MENRANT (NEHEMIAH 1:2) _____
BLUID (EZRA 1:2) _____	LEXIE (NEHEMIAH 1:3) _____
PETLEM (EZRA 1:2) _____	MELASUREJ (NEHEMIAH 1:3) _____
RUSVIVROS (EZRA 1:4) _____	GRACEDIS (NEHEMIAH 1:3) _____
TIVITPACY (EZRA 9:7) _____	AARRXXEETS (NEHEMIAH 2:1) _____

EZRA HELPED REBUILD THE
TEMPLE,
NEHEMIAH HELPED REBUILD
THE WALL.
I CAN HELP BUILD UP GOD'S
KINGDOM,
WHEN I GIVE GOD MY ALL!

Core/Scripture Memory

1 copy for the teacher (Optional - heavy paper)

Perseverance	must	finish	its
work	so	that	you
may	be	mature	and
complete,	not	lacking	anything.



This page intentionally left blank

Wall of Fame

build Hanani survivors disgrace wall temple Ezra Nehemiah King Cyrus Persia King Artaxerxes Jerusalem

Ezra Nehemiah King Cyrus Persia King Artaxerxes Jerusalem captivity exile remnant

Ezra

Nehemiah

King Cyrus

Persia

King Artaxerxes

Jerusalem

captivity

exile

remnant

build

Hanani

survivors

disgrace

wall

temple

captivity exile remnant build Hanani survivors disgrace wall temple Ezra Nehemiah

King Cyrus Persia King Artaxerxes Jerusalem captivity exile remnant build Hanani survivors disgrace wall