

Abraham and Lot

Lesson Objectives

- The students will compare and contrast choices that Abraham and Lot made.
- The students will identify two choices that Lot made that hurt his family.
- The students will use the Bible to make good choices.

Lesson Text

Genesis 12-14, 18-19

Scripture Memory Verse

The world and its desires pass away, but the man who does the will of God lives forever.

1 John 2:17

Lesson Plan

Greeting and Registration

Preclass Activity: Story Cups

Welcome and Singing

Centers:

Bible Story: Great Choices

Craft: What in the World?

Scripture Memory: Filtered Vision

NOTE: Allow time for a snack.



Abraham and Lot

Story Cups

The students will preview today's lesson by making story figures for use during the Bible Story.

Materials

For each student:

- scissors
- 1 glue stick or invisible tape
- 5 craft sticks or straws
- 1 large paper cup (not styrofoam)
- crayons or colored pencils

Reproducible Pages:

- Page A, 1 copy for each student

Preparation

Make a set of story figures as models from your copy of Page A to show the students.

Instructions

1. As the students arrive, show them your sample set of story figures and tell them that they will use story figures during today's Bible Story.
2. Distribute copies of Page A, scissors, glue sticks, craft sticks, paper cups, and crayons to the students.
3. Have them cut out the five story figures from their copies of Page A and glue each one to a craft stick.
4. Have the students write their names on their cups and on the backs of each story figure. Then have them place their figures in their cups.
5. If time permits, have the students color their story figures.
6. Collect the students' cups and give them to the Bible Story teacher for use in the Bible Story Center.

Teacher Tips

- Prepare for latecomers by allowing some students to make a second set of figures.



Abraham and Lot

Great Choices

The students will compare and contrast characteristics of Abraham and Lot and consider the results of their choices.

Materials

For each student:

- 1 set of story figures from the preclass activity

For the teacher:

- 1 set of story figures (model from the preclass activity)

Preparation

1. Read the passages in Genesis indicated below for a better understanding of the events of the story.
2. Practice telling the story using the story figures.

The Journey Together (Genesis 12:1-5)

Tell the students to hold up their puppets when you do and follow the story as you tell it. Have your Bible open and hold up the Abraham puppet, saying: *Let's take out Abraham and begin our journey in Genesis 12. God told Abraham to leave his country and to go to a new land. At that time, Abraham was considered quite wealthy. He and his wife owned many things. They had animals, tents, and servants. When Abraham left Haran for the new land, he took all his possessions and his nephew with him. His nephew's name was Lot. Hold up the Lot puppet. Lot also had many possessions. Together, they all left to go to the new land. Place the two figures side by side as if they are walking together.*

Going Separate Ways (Genesis 13:5-18)

After they had been traveling for some time, Abraham and Lot began to have a problem. They realized that they both had so many animals and so many servants that there really wasn't room enough for everyone to be happy. Some of the herdsman who took care of the animals began to argue. Abraham knew that this was not good. He did not want fighting in the family. Hold the puppets face to face as if they are talking. He spoke to Lot and they decided to go separate ways. Abraham told Lot that he could choose to go wherever he wanted and Abraham would go the other way. The Bible says, "Lot looked up and saw that the whole plain of the Jordan

was well-watered, like the garden of the LORD...So Lot chose for himself the whole plain of the Jordan and set out toward the east." Move the puppets apart as if they are walking in separate directions. Abraham then went the other way toward Canaan. He let Lot choose first, and Lot chose the land that looked good. After Lot was gone, God spoke to Abraham. He told him, "Lift up your eyes from where you are and look north and south, east and west. All the land you see I will give to you and your offspring forever. I will make your offspring like the dust of the earth...Go, walk through the length and breadth of the land, for I am giving it to you." And Abraham built an altar to worship the Lord.

Big Problems for Lot (Genesis 14:11-16)

Lot moved to a land called Sodom. Hold up the Lot puppet alone. The people who lived in Sodom were sinful and did terrible and wicked things against God. One time, some wicked kings came from another land to attack the people of Sodom. Hold up the Enemies puppets as if they are marching toward Lot. They attacked Sodom, taking food and supplies and prisoners. They kidnapped Lot and all his possessions! Put the Lot puppet down. A messenger heard about this and ran to tell Abraham. Abraham had people from his household who agreed to help him rescue Lot. Show Abraham marching toward the Enemies. He and his men attacked the enemies and rescued Lot. Hold up the Lot puppet. Lot returned to his home safely.

Blessing for Abraham (Genesis 14:17-24)

Hold up the Abraham puppet. As Abraham was going home, he was met by a two kings. One of the kings was also a priest. Hold up the Two Kings puppet. His name was Melchizedek (Mel kiz a dek). Can you all say Melchizedek? He blessed Abraham and told him that God had truly helped him to rescue Lot. After Abraham received the blessing, he gave Melchizedek a great gift. Then the other king wanted to give Abraham a gift for rescuing Lot, but Abraham refused to accept anything. He wanted that king to know that it was God who made him successful, and not any man—not even a king!



Abraham and Lot

More Trouble for Lot (Genesis 18:1-33, 19:1-29)

Hold up the Abraham puppet. *When Abraham was ninety-nine years old, some angels came to visit him.* Hold up the Angels puppet. *They told him that God was planning to destroy Sodom and Gomorrah because of their sin. Abraham asked if they would destroy Sodom even if there were some righteous people still there. God said that if he could find ten righteous people, he would not destroy the city.*

Put down the Abraham puppet. Hold up the Angels puppet. *The two angels went to Sodom, where they met Lot.* Hold up the Lot puppet. *Lot invited them to stay at his house. After they arrived at Lot's house, some neighbors started banging on the door.* Hold up the Enemies puppet. *They demanded that the visitors come outside. These neighbors wanted to do something wicked to them. Lot was very upset and told the people that they should not do such a wicked thing. He told them that they could take his daughters instead. The neighbors were angry and started to break down the door, but the angels stopped them by causing them to become blind. The angels told Lot and his family to leave the city at once because God was going to destroy it. They told Lot to run to the mountains. He asked if they could run to a small town outside of the city instead, and the angels agreed. The angels told them to run as fast as they could and not to look back. As Lot and his family were running away, Lot's wife looked back—and she turned into a pillar of salt. Lot and his daughters made it to the town and lived in a cave. God completely destroyed the cities of Sodom and Gomorrah.*

Story Review

Use the following questions to help students think about the results of Abraham and Lot's choices:

Holding the Abraham puppet, ask:

- *What are some choices that Abraham made in the story? (going to a new land, separating from Lot, giving Lot the first choice of land, rescuing Lot, refusing to accept the king's gift)*

Holding the Lot puppet, ask:

- *What are some choices that Lot made in the story? (to take the land that looked good, to live near a wicked city, to protect his visitors, and to offer his daughters to the wicked people)*

Holding the Abraham puppet, ask:

- *What happened to Abraham after he let Lot have the first choice of the land? (God blessed him and told him that his children would inherit all of the land around him.)*

Holding the Lot and Enemies puppets, ask:

- *What happened to Lot after he moved to the land near Sodom? (He was kidnapped and taken prisoner by wicked kings.)*

Holding the Abraham and Two Kings puppets, ask:

- *What happened to Abraham after he rescued Lot? (The priest and the king came to bless him and to thank him.)*

Holding the Lot and Angel puppets, ask:

- *What happened to Lot after he returned to his home? (His neighbors tried to attack his visitors and hurt his family.)*

Holding the Abraham and Lot puppets, ask each student one at a time:

- *Who do you think made the best choices? Why?*

Sharing with Others

Abraham made faithful choices and he was blessed. We can make faithful choices too! Let's all decide that we are going to share our faith with someone this week. Let's pray about sharing with someone who has to make an important decision. We can tell this person about Abraham and the way he used his faith to make his choices.

Close with a prayer.

Teacher Tips

- Practice telling the story several times before presenting it to the students.

C

R

A

F

T

Abraham and Lot

What in the World?

The students will think about some things that they value and consider how they can use them to do God's will.

Materials

For each student:

- magazine pictures of games, toys, movies, sports, food, computers, etc.
- 1 glue stick
- 1 piece of construction paper
- thin markers or colored pens

Reproducible Pages:

- Page B, 1 copy for each student

Preparation

1. Prepare a model to show the students.
2. Cut out enough magazine pictures for each student to choose one.
3. Cut out Figures One and Two from the students' copies of Page B prior to class.

Instructions

1. Introduce the craft by saying: *Today you are going to make a craft that will remind you to do what God wants you to do—just like Abraham did! Show students your model. The memory verse tells us that the world and its desires will pass away, but the man who does the will of God will live forever. That means that the world and the things that we like to do—watching television, eating food, playing games—will one day be gone, but we will live forever if we do God's will. Doing God's will means doing what God wants, not just what we want. How do we know what God wants us to do? (by reading the Bible, asking a disciple) Look at my picture. Here is a picture of something that I like to do. I have glued it in the middle of the picture of the world. It is something "in the world" that I like. I want to do God's will with it, so at the bottom of the page I have written one way that I can use it to do God's will. Share what you have written in the Big Idea box.*

2. Distribute the precut figures from the students' copies of Page B, the construction paper, markers, magazine pictures, and glue sticks.
3. Have the students fold the pieces of construction paper width-wise. See Figure A.
4. Tell the students to each choose one picture of something that they like to do and glue it to the "world" in the space indicated. See Figure B.
5. In each Big Idea box, have the students write their ideas for how to do God's will with the items in the pictures they have chosen. Be sure that they write their names on their projects.
6. Have the students glue the "world" onto one side of their construction papers and the Big Idea box onto the other. See Figure C.

Conclusion

Go around in a circle and have the students share what they chose and how they will use their choices to do God's will. Share from your own life about a way in which you have used your possessions to do God's will. Close with a prayer asking God to help them make good choices.

Teacher Tips

- Make sure to cut out more than enough pictures for the students to choose from.

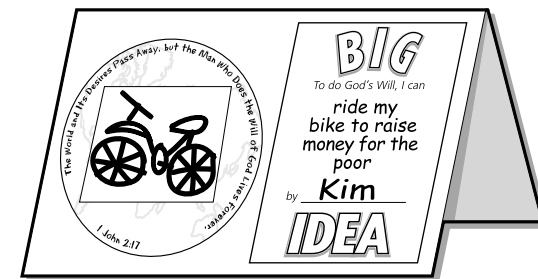

3rd and 4th Grades

Abraham and Lot

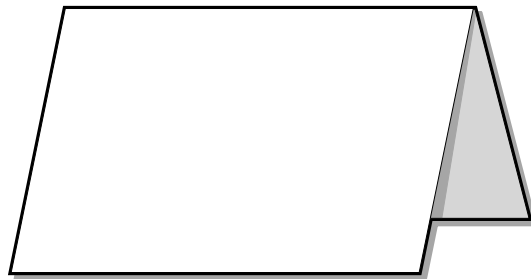

Figure A



Figure B

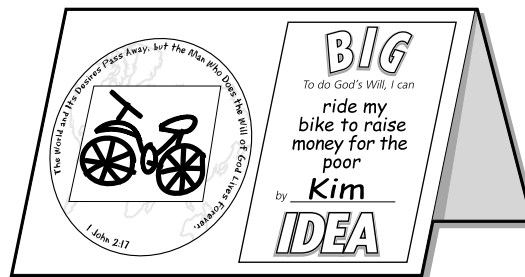

Figure C

Abraham and Lot

Filtered Vision

The students will uncover the hidden memory verse as they consider the effects of distractions that obscure the truth in their lives.

Scripture Memory Verse

The world and its desires pass away, but the man who does the will of God lives forever.

1 John 2:17

Materials

For each student:

- red marker
- green highlighter
- 1 piece of cardboard, 8" x 11"
- 1 piece of red cellophane, 6" x 9"
- 1 piece of white, lined paper
- pencil

For the teacher:

- scissors
- invisible tape

Reproducible Pages:

- Page C, 1 copy for each pair of students

Preparation

1. Make a cardboard frame for each student by cutting out the inside of the cardboard, leaving a 2" frame. See Figure A.
2. Tape the red cellophane to the inside of the frame. See Figure B.
3. Using the green highlighter, fill in the words on the copies of Page C for each student.
4. Using a red marker, draw over the words with lines and shapes to obscure the verse on the pages. See Figure C.
5. Be sure that the red cellophane effectively "filters" the red marks so that the verse is visible. You may need to try different markers until you find the right shade of red.

Instructions

1. Introduce the memory verse by saying: *Today's memory verse helps us to think about how to make decisions to do God's will. We learned in our Bible Story that Abraham was a man who wanted to do God's will. He had to make many choices in his*

life, and the Bible says that he was blessed for making decisions that pleased God.

2. Show the students your copy of Page C with the obscured verse written on it. Ask them if they can see the words. Place Page C under the cellophane viewer and show it to them again. Ask the question again. Have the students read the verse with you.
3. Have the students work in pairs. Distribute the copies of Page C that you prepared to each pair of students. Ask them to try to find the words to the verse.
4. Distribute the viewers and let them find the words. Tell them to say the verse three times to each other.
5. Have each student write the verse on the lined paper three times.

Conclusion

Tell the students that the words on the pages were hidden by red marks. The marks made it difficult to see the verse. Tell them that sometimes there are distractions in our lives that have the same effect. Give the following example: *We know that we should read our Bibles, but other things get in the way. They are called distractions. Have you ever wanted to watch television more than go to church? Have you ever wanted to play a computer game more than pray to God? Televisions and computers are not bad, but they can distract us and keep us from doing the things that please God. They can be like the red marks on the papers and keep us from seeing that God wants to spend time with us. Who can think of some other distractions? Take responses. End the discussion with a prayer for the students to love God more than anything else in the world.*

Teacher Tips

- Red cellophane can be purchased at most craft supply stores and in some grocery stores during holiday seasons.

Abraham and Lot

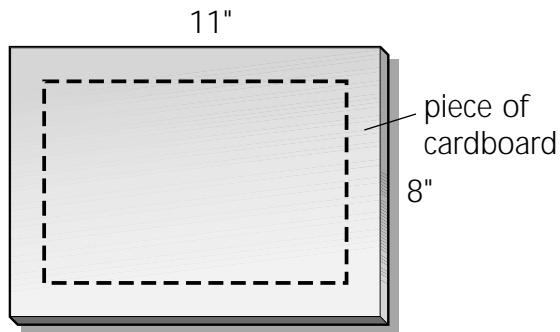

Figure A

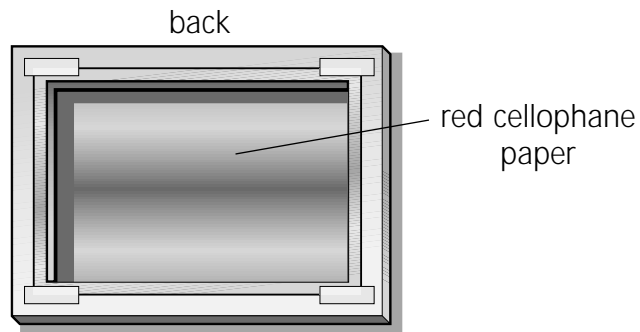
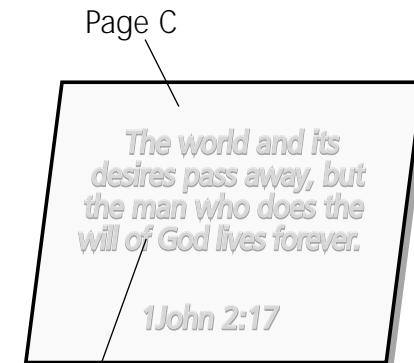
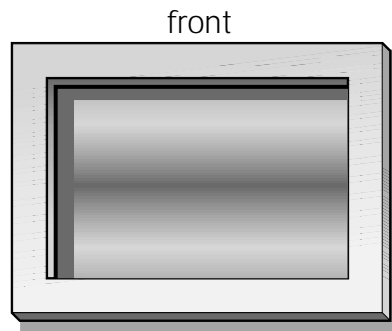
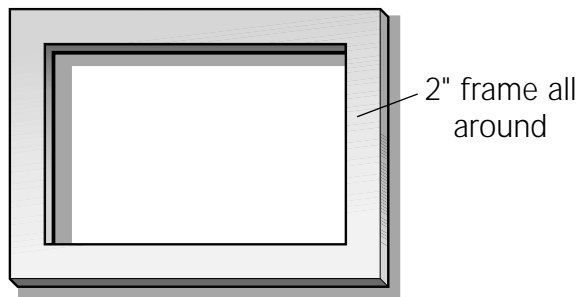
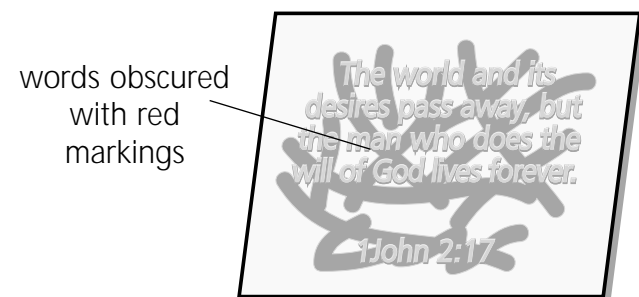

Figure B



words written in green highlighter

Figure C



Lesson Objectives

- The students will compare and contrast choices that Abraham and Lot made.
- The students will identify two choices that Lot made that hurt his family.
- The students will use the Bible to make good choices.

Lesson Text

Genesis 12-14, 18-19

Scripture Memory Verse

The world and its desires pass away, but the man who does the will of God lives forever.

1 John 2:17

Lesson Plan

Greeting and Registration

Preclass Activity: Just the Facts

Welcome and Singing

Centers:

Life Application: Father Knows Best

Game: Decision Point

Bible Skills: What Do You Know?

NOTE: Allow time for a snack.

Just the Facts

Circle the statements below that are true. Put a line through the statements that are false.

Example:
Abraham was a poor man with no animals, tents or servants. (Genesis 12:1)
Abraham took his nephew with him to go to the new land. (Genesis 13:5-11)

1. Abraham's nephew's name was Spot. (Genesis 12:5)
2. Lot also had many possessions of his own. (Genesis 13:5)
3. Abraham and Lot had to go in different directions. (Genesis 13:9)
4. Abraham did not want fighting in the family. (Genesis 13:8)
5. Abraham chose the land that he wanted first and gave the leftovers to Lot. (Genesis 13:9)
6. God blessed Abraham for letting Lot choose first. (Genesis 13:14-17)
7. Lot lived near a city where the people were wicked and sinned against God. (Genesis 13:12)
8. Some enemies came and attacked Abraham in his home. (Genesis 14:11-12)
9. Abraham and his neighbors came and rescued Lot. (Genesis 14:13-16)
10. A king and a priest wanted to thank Abraham for rescuing Lot. (Genesis 14:17-18)
11. The priest's name was Melchizedek. (Genesis 14:18)
12. Five angels stayed at Lot's house. (Genesis 19:1-3)

13. Lot's neighbors were very kind to Lot's visitors. (Genesis 19:9)
14. The angels made the neighbors sleepy. (Genesis 19:11)
15. Lot and his family escaped to a small town. (Genesis 19:20,23)
16. Lot's daughter looked back and was turned into a pillar of salt. (Genesis 19:24)
17. God completely destroyed Sodom and Gomorrah. (Genesis 19:28,29)

Write the correct answers to the false statements in the box below.

Example: Hordhan was very wealthy.

P
R
E
•
C
L
A
S
S

Just the Facts

Students will review important ideas from this week's Bible Story.

Materials

For each student:

- pencil
- Bible

Reproducible Pages:

- Page D, 1 copy for each student

Preparation

Complete your copy of Page D prior to class.

Instructions

1. Distribute copies of Page D and pencils to the students as they arrive.
2. Have the students work together and use their Bibles.
3. Encourage the students who have not heard the Bible Story to work with those who did.
4. Circulate among them to offer assistance.
5. When they are finished, the students can check their work with your answer key.

Answer Key

(1.)F (2.)T (3.)T (4.)T (5.)F (6.)T (7.)T
(8.)F (9.)T (10.)T (11.)T (12.)F (13.)F
(14.)F (15.)T (16.)F (17.)T

Teacher Tips

- Know your students! Be prepared to help those who have trouble finding passages in the Bible.



3rd and 4th Grades

L i f e A p p l i c a t i o n

Father Knows Best

The students will use their Bibles to help them make good decisions about their daily activities.

Materials

For each student:

- pencil
- Bible

For the teacher:

- large writing surface

Reproducible Pages:

- Page E, 1 copy for each student

Preparation

1. On the large writing surface, prepare a chart with four columns, labeled: Money, Friends, Parents, Talking. You will use it to record the students' answers.
2. Have the following passages marked in your Bible in advance: 1 Timothy 6:18, Proverbs 17:17, Ephesians 6:1, 1 Corinthians 13:5.

Reviewing the Bible Story

Introduce the activity by saying: *This week we learned about Abraham and Lot and the decisions they made. We saw that they had very different lives because of those decisions. Abraham was blessed by God for his decisions, while Lot had many sad things happen to him and his family because of his decisions. Today we are going to read the Bible to learn how we can make good decisions for our lives.*

Reading the Bible Together

Show the students your chart. Tell them that they are going to see what God says about money, friends, parents and talking. These are four areas in their lives in which they make choices every day. Give them the following example, saying: *You choose to spend money. You choose how you will treat your friends. You choose how you will treat your parents. You choose how you will talk and to whom you will talk. Today we want to find out: How does God want you to use your money? How does God want you to treat your friends and your parents? How does God want you to talk to people?*

Point to the Money Column. Tell the students to turn to

1 Timothy 6:18. Read the verse aloud. Ask them: *How does God want you to spend your money?* Write their responses on the chart.

Point to the Friends Column. Have the students turn to Proverbs 17:17. Read it aloud. Ask them: *How does God want you to treat your friends?* Record their responses on the chart. Some of the students may not know what the word "adversity" means. Explain that it is when something bad happens. An additional point from the verse that you will want to explain is that God wants us to be great friends with our brothers and sisters, too!

Point to the Parents Column. Have the students turn to Ephesians 6:1. Read it aloud. Ask them: *How does God want you to treat your parents?* Record their responses.

Point to the Talking Column. Have the students turn to 1 Corinthians 13:5. Read it aloud. Ask them: *How does God want you to talk to people?* Record their responses.

Life Application

Distribute copies of Page E to the students. Have them fill in the chart with ways to do God's will in each area. Circulate among them to offer help with spelling and questions.

Conclusion

Have the students each tell the group how they will choose God's will in one of the four areas discussed. Close with a prayer for everyone to make godly decisions.

Teacher Tips

- Students who do not complete the activity can finish it at the end of class or at home.

	Money	Friends	Parents	Talking
God Says				
	1 Timothy 6:18	Proverbs 17:17	Ephesians 6:1	1 Corinthians 13:5



3rd and 4th Grades



Decision Point

The students will review the events from this week's Bible Story as they consider the effects of good and bad decisions.

Materials

For the teacher:

- 10 index cards, 3" x 5"
- 1 thin, black felt-tip pen
- 2 game tokens
- 1 die, from a pair of dice
- game board on opposite side of this card

Preparation

1. Cut each card in half to make twenty 2½" x 3" cards, then divide the cards into one set of seven and one set of thirteen.
2. On the set of seven, write: Decision Point. On the set of thirteen, write: Challenge.
3. On the opposite side of each Decision Point card write one of the following statements:
 - You decide to allow Lot to have the first choice. Advance one space.
 - You decide to live near Sodom, where people are sinning against God. Spend one night in Lot's tent. Lose a turn.
 - God blesses your decision to allow Lot to choose first. Advance one space.
 - You decide to rescue Lot from the wicked kings. Advance one space.
 - God blesses your decision to honor him. Advance one space.
 - You decide to protect your visitors instead of your family. Spend one night in Lot's tent. Lose a turn.
 - You decide to run to a small town instead of the mountains. Go back two spaces.
4. On the opposite side of each Challenge card write one of the following questions, without the answers:
 - True/False: Lot had many possessions of his own. (T)
 - True/False: Abraham did not want fighting in the family. (T)
 - True/False: Lot lived near a city where the people were wicked and sinned against God. (T)
 - True/False: Abraham had people in his household who helped him. (T)



- True/False: Two kings wanted to thank Abraham for rescuing Lot. (T)
 - True/False: One of the kings was also a priest named Melchizedek. (T)
 - True/False: Five angels stayed at Lot's house. (F)
 - True/False: Lot's neighbors were very kind to Lot's visitors. (F)
 - True/False: The angels made Lot's neighbors sleepy. (F)
 - True/False: Lot and his family escaped to a small town. (T)
 - True/False: Lot's daughter looked back and was turned into a pillar of salt. (F)
 - True/False: God completely destroyed Sodom and Gomorrah. (T)
5. Choose a game piece for each team.

Instructions

1. Explain to the students that today's game will help them to understand the results of good and bad decisions and will test their knowledge of the Bible Story.
2. Divide the students into two teams and assign a game piece to each team. Place each game piece on a different starting space.
3. Choose the team that will begin. The object of the game is to be the first team to enter Abraham's tent.
4. A player from the first team rolls the die and advances that many spaces. If the player lands on a "D" space, he is to choose a Decision Point card and follow the direction given. Then the card is to be placed at the bottom of the pile. If he lands on a "C" space, he is to choose a Challenge card and answer the question. Team members may discuss an answer, but only the player may give the final answer. If he answers correctly, the team may advance one space. Then the Challenge card is to be placed at the bottom of the pile.
6. Play continues until a team rolls the exact number to enter the door of Abraham's tent.

Teacher Tips

- Be sure to practice playing the game at home prior to class.



G
A
M
E

ROLL 3 OR 5 TO START

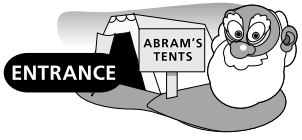
ENTRANCE 

DECISION POINT
i
DECISION POINT

DECISION POINT
D
DECISION POINT

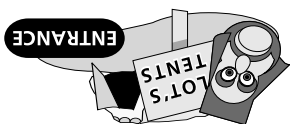
ENTRANCE 

ROLL 3 OR 5 TO START

GENERATION next

The board game is a maze of footprints. The starting area at the top left has a row of footprints: three white, one black with a question mark, three white, and one black with a question mark. The ending area at the top right has three white footprints followed by a black footprint with a 'D'. The starting area at the bottom right has a row of footprints: three white, one black with a question mark, three white, one black with a 'D', three white, and one black with a question mark. The ending area at the bottom left has three white footprints, one black with a question mark, three white, and one black with a question mark. The maze contains various combinations of white and black footprints, some with question marks or 'D's. Two large 'DECISION POINT' cards are placed on the board. The left card has a large white 'i' on a black background. The right card has a large white 'D' on a grey background. Two curved arrows point from a central black footprint with a white 'D' to two adjacent white footprints.

What Do You Know?

The students will test their knowledge of the Old Testament books of the Bible.

Materials

For each student:

- pencil
- Bible

Reproducible Pages:

- Page F, 1 copy for each student

Preparation

Complete the quiz on your copy of Page F prior to class.

Instructions

1. Explain to the students that they will have a review quiz of the books of the Old Testament. The purpose of the quiz is to help them see how well they still know the order of the books.
NOTE: Allow students who are new or who were absent during Unit 1 to complete the quiz using Bibles. They should be seated separately from those taking the quiz without Bibles.
2. Give the students five minutes to study their Bibles and review for the quiz.
3. Tell the students that they will have ten minutes to complete the quiz. After ten minutes, they will exchange papers and see how they did.
4. Distribute the quizzes and pencils. Be sure that students are working independently. They may not look at each other's papers.
5. Keep the time. After ten minutes, tell the students to put down their pencils. Have them exchange their papers with one another.
6. Go around the circle and let students take turns giving answers. You give the final correct answer.
NOTE: Do not allow students to make fun of those who do not do well.

Conclusion

Ask the students if they are doing their best to spend time reading the Bible every day. Encourage them to ask their parents or friends to quiz them on the Old Testament books once a week for fun. Close with a prayer for them to be great Bible students.

Teacher Tips

- Make extra copies of the quiz to be used as an additional preclass activity or optional homework for students who want extra challenge.

Old Testament Books of the Bible Quiz

Answer Key

Multiple Choice

- How many books are in the Old Testament?
b.) thirty-nine
- What is the first book of the Old Testament?
b.) Genesis
- Which book is not in the Old Testament?
c.) Revelation
- Fill in the blank: Genesis, Exodus, Leviticus, Numbers, _____
a.) Deuteronomy
- Fill in the blank: Joshua, _____, Ruth
b.) Judges

Matching Questions

- | | |
|---|---------|
| 1. What is the book before Hosea? | Daniel |
| 2. The last book of the Old Testament is? | Malachi |
| 3. What is the book after Deuteronomy? | Joshua |
| 4. Which book is after 1 Kings? | 2 Kings |
| 5. Which book is before Psalms? | Job |

Put Them in Order

Genesis	1 Kings	Ecclesiastes	Obadiah
Exodus	2 Kings	Song of Songs	Jonah
Leviticus	1 Chronicles	Isaiah	Micah
Numbers	2 Chronicles	Jeremiah	Nahum
Deuteronomy	Ezra	Lamentations	Habakkuk
Joshua	Nehemiah	Ezekiel	Zephaniah
Judges	Esther	Daniel	Haggai
Ruth	Job	Hosea	Zechariah
1 Samuel	Psalms	Joel	Malachi
2 Samuel	Proverbs	Amos	

Core/Preclass
1 copy for each student

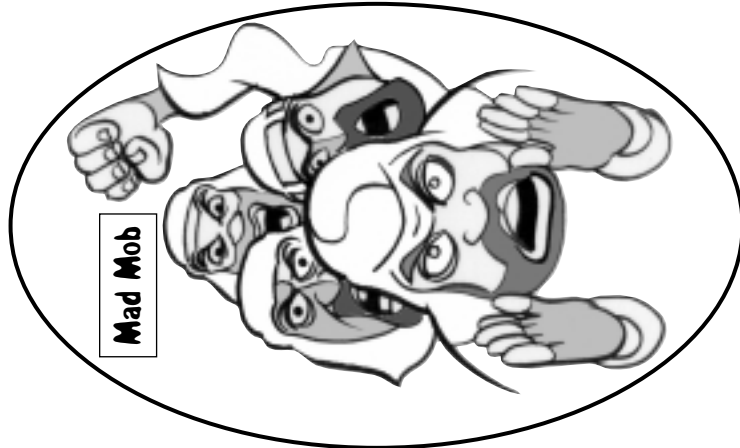
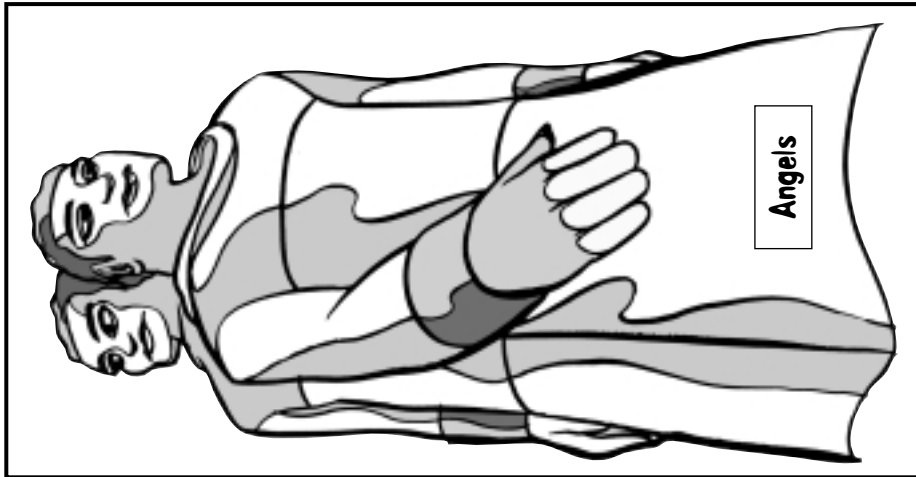
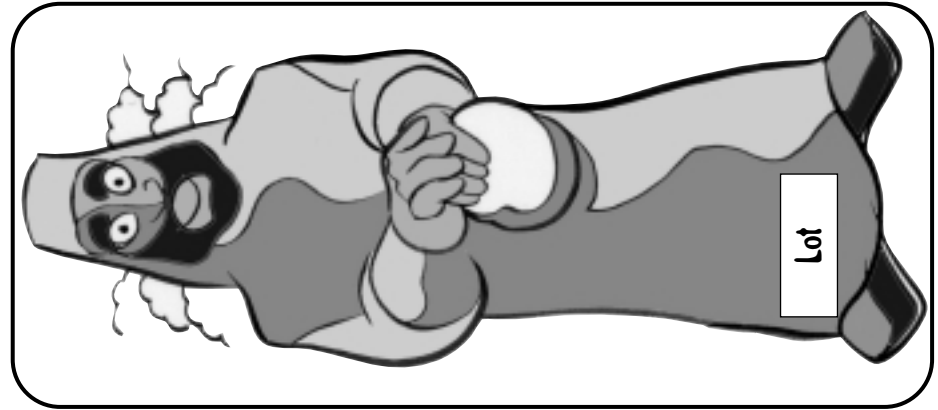
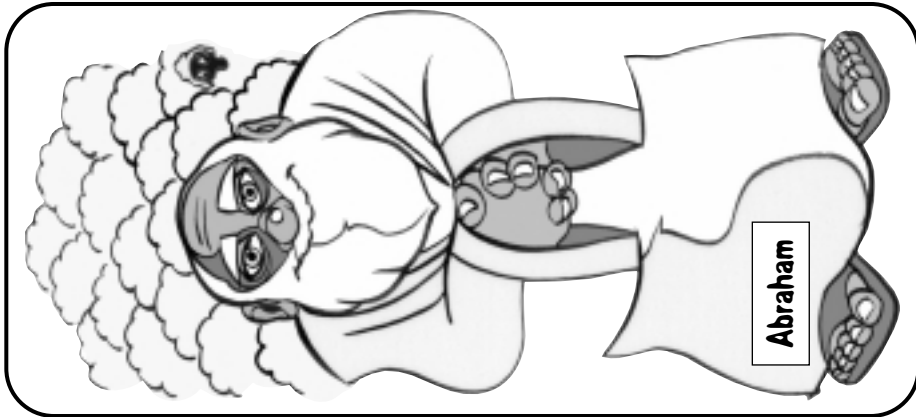

Core/Craft
1 copy for each student



Figure 1

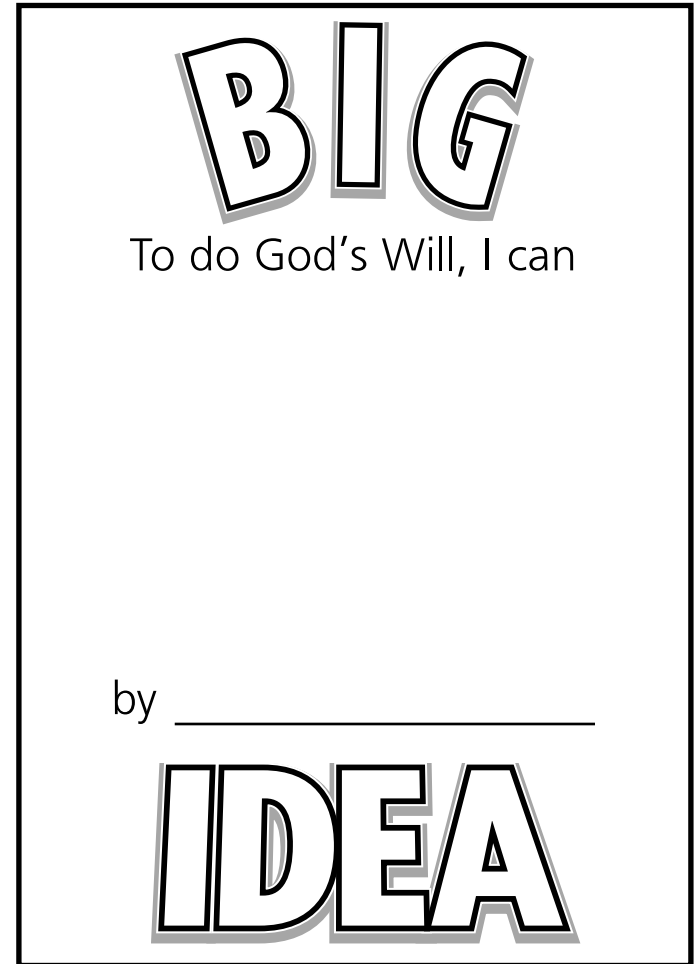

Figure 2

The world and its
desires pass away, but
the man who does the
will of God lives forever.

1 John 2:17

This page intentionally left blank



Supplement/Preclass

1 copy for each student

Just the Facts

Circle the statements below that are true. Put a line through the statements that are false.

Example:

~~Abraham was a poor man with no animals, tents or servants.
(Genesis 13:2)~~

Abraham took his nephew with him to go to the new land.
(Genesis 13:5-11)

1. Abraham's nephew's name was Spot. (Genesis 12:5)
2. Lot also had many possessions of his own. (Genesis 13:5)
3. Abraham and Lot had to go in different directions. (Genesis 13:9)
4. Abraham did not want fighting in the family. (Genesis 13:8)
5. Abraham chose the land that he wanted first and gave the left-overs to Lot. (Genesis 13:9)
6. God blessed Abraham for letting Lot choose first. (Genesis 13:14-17)
7. Lot lived near a city where the people were wicked and sinned against God. (Genesis 13:13)
8. Some enemies came and attacked Abraham in his home. (Genesis 14:11-12)
9. Abraham and his neighbors came and rescued Lot. (Genesis 14:13-16)
10. A king and a priest wanted to thank Abraham for rescuing Lot. (Genesis 14:17-18)
11. The priest's name was Melchizedek. (Genesis 14:18)
12. Five angels stayed at Lot's house. (Genesis 19:1-3)

13. Lot's neighbors were very kind to Lot's visitors. (Genesis 19:9)
14. The angels made the neighbors sleepy. (Genesis 19:11)
15. Lot and his family escaped to a small town. (Genesis 19:20,23)
16. Lot's daughter looked back and was turned into a pillar of salt. (Genesis 19:26)
17. God completely destroyed Sodom and Gomorrah. (Genesis 19:28-29)

Write the correct answers to the false statements in the box below:

Example: *Abraham was very wealthy.*

Supplement/Life Application

1 copy for each student

	Money	Friends	Parents	Talking
I will choose God's will...				



3rd and 4th Grades

Answer the following questions about the books of the Bible:

Multiple Choice

Circle the correct answer:

- How many books are in the Old Testament? a.) one hundred
b.) thirty-nine c.) five d.) three hundred and ninety
- What is the first book of the Old Testament?
a.) John b.) Genesis c.) Malachi d.) 1 Kings
- Which book is not in the Old Testament?
a.) Exodus b.) Jonah c.) Revelation d.) Psalms
- Fill in the blank: Genesis, Exodus, Leviticus, Numbers, _____
a.) Deuteronomy b.) David c.) Letters d.) 2 Numbers
- Fill in the blank: Joshua, _____, Ruth
a.) 2 Joshua b.) Judges c.) Moses d.) Romans

Matching Questions

Draw a line to the correct answer:

- | | |
|---|---------|
| 1. What is the book before Hosea? | Malachi |
| 2. The last book of the Old Testament is? | Job |
| 3. What is the book after Deuteronomy? | Joshua |
| 4. Which book is after 1 Kings? | Daniel |
| 5. Which book is before Psalms? | 2 Kings |

Put Them in Order

Below are all of the books in the Old Testament. On the back of this paper, write them in the correct order.

- | | | | |
|--------------|---------------|--------------|-----------|
| Genesis | 2 Chronicles | Daniel | Exodus |
| Ezra | Hosea | Leviticus | Nehemiah |
| Joel | Numbers | Esther | Amos |
| Deuteronomy | Job | Obadiah | Joshua |
| Psalms | Jonah | Judges | Proverbs |
| Micah | Ruth | Ecclesiastes | Nahum |
| 1 Samuel | Song of Songs | Habakkuk | 2 Samuel |
| Isaiah | Zephaniah | 1 Kings | Jeremiah |
| Haggai | 2 Kings | Lamentations | Zechariah |
| 1 Chronicles | Ezekiel | Malachi | |