

Jonah Obeyes

More Heroes of Old
Lesson 2

Lesson Objectives

- The children will thank God for helping them to do what is right.
- The children will state that they can make God happy by repenting if they're doing something wrong.
- The children will draw a picture of one thing that they can do to obey God.

Lesson Text

Jonah 3

Scripture Memory Verse

The Lord provided a great fish to swallow Jonah.

Jonah 1:17

Lesson Plan

Greeting and Registration

Preclass Activities: Fish Book-1

Welcome and Singing

Centers:

Bible Story: Jonah Learns To Obey

Life Application: God Directs My Footsteps

Craft: Fish Book-2

NOTE: Be sure to allow sufficient time for a snack.

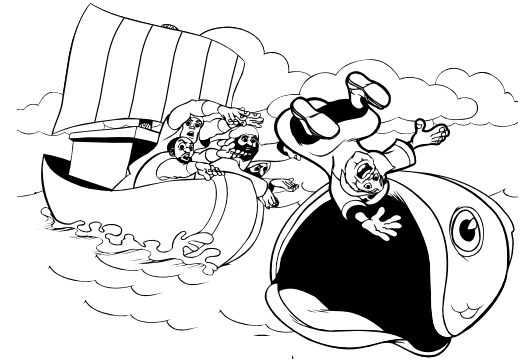

Pre
class

A
C
O
F
F
I
V
I
T
E
S

Jonah Obeys

Fish Book-1

The children will decorate their book covers for the craft.

Materials

For each child:

- glue stick
- stars, shapes, bows and other decorative items
- markers
- poster board, 11" x 17"

For the teacher:

- scissors
- glue
- clear contact paper or laminate, optional

Reproducible Pages:

- Page A, 1 copy for the teacher

Preparation

1. Cut out the fish stencil from the copy of Reproducible Page A.
2. Trace and cut out two fish shapes for each child from poster board.
3. Punch two holes in the tail of each fish shape.
4. On half of the fish shapes write the memory verse "The Lord provided a great fish to swallow Jonah. Jonah 1:17"

Instructions

1. Give each child two fish shapes to color and decorate. One of the shapes should have the memory verse on it.
2. Have the children put their names on their fish shapes.
3. Give the fish shapes to the Craft Center teacher.

Conclusion

As the children work have them tell the story of Jonah.

Teacher Tips

When the children finish decorating, collect the fish shapes and laminate each one with clear contact paper

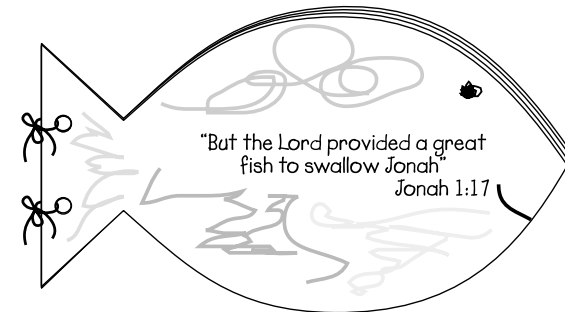

Jonah Obey's

Jonah Learns to Obey

The children will hear how Jonah learned to obey God and how he helped Nineveh to repent.

Lesson Text

Jonah 3

Materials

For the teacher:

- Bible
- adult shoe box
- 2 paper towel tubes
- utility knife
- pencil
- newsprint
- tape

Reproducible Pages:

- Page B, 1 copy for the teacher
- Page C, 1 copy for the teacher
- Page D, 1 copy for the teacher

Preparation

1. Make the "Old Testament television" box as follows: See Figure A.
 - A. Remove and discard the lid of the shoe box.
 - B. Place the shoe box on its side.
 - C. Trace two circles onto one side of the shoe box using the end of a paper towel tube as a stencil.
 - D. Cut out the two circles with a utility knife.
2. Make the television images as follows:
 - A. Cut out and color the pictures from the copies of Reproducible Pages B, C and D.
 - B. Cut a piece of newsprint 8" x 35".
 - C. Glue the pictures onto the newsprint leaving two inches on each end. See Figure B.

3. Assemble the television as follows:
 - A. Place a paper towel tube in each hole in the side of the shoe box.
 - B. Tape the end of the newsprint with picture three onto the right paper towel tube. See Figure C.
 - C. Turn the right tube, rolling the paper until picture one is showing.
 - D. Tape the end of the newsprint with picture one onto the left paper towel tube. See Figure D.
4. Practice rolling the tubes to make the pictures change as you tell the story.

Instructions

Open the Bible to the book of Jonah. *Last week, we learned about a man named Jonah. God told Jonah to go to the city of Nineveh to tell the people to stop doing bad things. Do you remember what Jonah did? Have the children volunteer answers. That's right! Jonah ran away from God! Maybe he was afraid to do what God told him to do. Can you tell me how God helped Jonah to obey him? Have the children volunteer answers. Great Job! God sent a very big fish to swallow Jonah. (Jonah 1:1-3, 17)*

Show the children the first picture in the television

Now that we know that Jonah learned to obey, let's see what he did next. God came to Jonah a second time and said, "Jonah, I want you to go to Nineveh and tell the people I am very sad because they are doing bad things. Tell them I love them but, if they don't obey me, I will have to punish them. (Jonah 3:1-2)

Show the children the second picture in the television.

This time Jonah obeyed God and went to the city of Nineveh. Jonah told the people what God told him to say. He said, "God is very sad with you because you are doing bad things. Stop doing the wrong things and start obeying God. (John 3:3-4) It makes God very sad when you don't obey him.

Jonah Obey's

Show the children the third picture in the television.

When the King of Nineveh heard that God was sad, he took off his royal robe and put on sackcloth! He even sat in the dust. The King sent a message to all the people in Nineveh. Even the animals had to obey the King's command. The King said, "No people or animals are to eat any food. Everyone must pray to God and tell God they are sorry. Everyone must stop doing the wrong things and obey God! Maybe God will forgive us and not punish us." (Jonah 3:6-9) Do you think the people obeyed God? (Yes) What do you think God did? That's right! God saw that the people were sorry. He loved them very much and he forgave them. God did not punish the people because they obeyed him. (Jonah 3:10)

Conclusion

Ask the children the following questions to review the story:

- What did God want Jonah to do? (Tell the Ninevites to stop doing bad things and obey God.)
- What did Jonah do? (Jonah obeyed God; he went to the Ninevites and told them what God said.)
- What happened when Jonah talked to the Ninevites? (They stopped doing the wrong things and began to obey God.)
- What did the Ninevites do to show God they were sorry? (They did not eat; put on sackcloth; prayed and told God they were sorry.)

- What did God do? (When God heard their prayers he was happy and forgave them.)
- How do you think the Ninevites felt? (They were sorry for hurting God and excited to change and make God happy.)
- What can you do when you do something wrong? (say, "I'm sorry", pray to God, stop doing the wrong things and do the right things)

Teacher Tips

Cover the outside of the shoe box with construction paper so that it looks more like a television set.

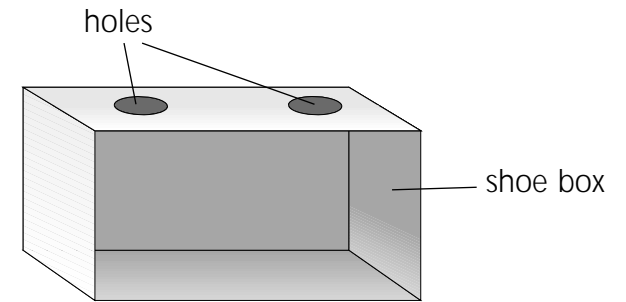

Figure A

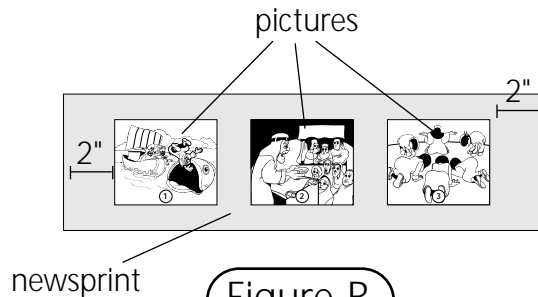

Figure B

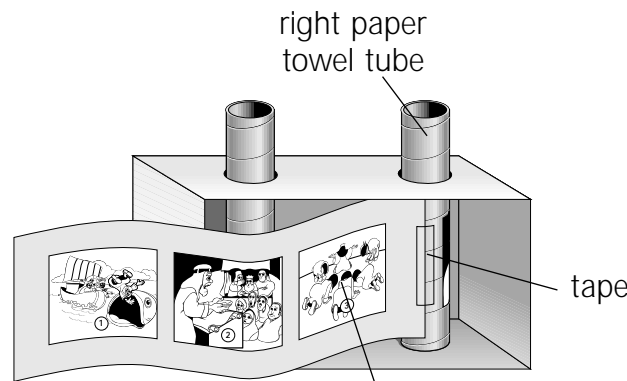

Figure C

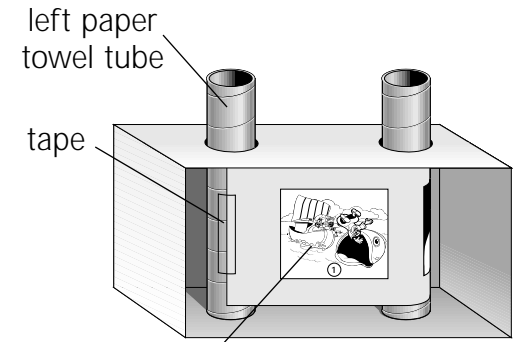

Figure D



Jonah Obeys

God Directs My Footsteps

The children will participate in making a mural to illustrate that God directs us and helps us just as he helped Jonah.

Scripture Memory Verse

The Lord provided a great fish to swallow Jonah.
Jonah 1:17

Materials

For each child:

- crayons and markers

For the teacher:

- 1 piece of poster board, 8½" x 11"
- butcher paper, 4'
- scissors
- brown paper bags or brown construction paper

Preparation

1. Trace your foot onto the poster board and cut it out to make a stencil.
2. Trace and cut out one footprint for each child from the brown paper bags. Make both left and right footprints.
3. Write the word "Heaven" at the top right hand corner of the butcher paper and draw clouds around the word.
4. Draw a path from the lower left corner of the butcher paper winding up to "Heaven." Draw flowers along the path.

Instructions

1. Ask the children how God helped Jonah to be obedient. (creating a big storm, having a big fish swallow him) *God wants to help all of us. Sometimes we need different kinds of help. Jonah wasn't listening to God so God did something very different. Did it help Jonah to pay attention? (yes) God wants us all to go to heaven and be with him. If we obey him, we will always be on the right path.*
2. Show the children the path that leads up to heaven.

3. Ask the children to name some things God tells us to do? (pray, share, be loving, help others, be kind, be happy) Write the list of things that they say along the path.
4. Give each child a footprint and have him draw a picture of himself doing something that God instructs us to do.
5. Have the children glue their footprints onto the path next to the words that correspond with their picture.

Scripture Memory Activity

Work with the children as a group and create hand and body movements to act out the memory verse. Have the children practice it and act it out for the group.

Conclusion

We probably will never be swallowed by a big fish when we are disobedient. But God does want us to obey him and the people he puts in our lives to help us do what is right. God is very kind and he wants us all to be with him in heaven, that is why he gives us our parents and teachers to help us to learn right from wrong.

God can use you to help your friends learn also. You can tell them the story about Jonah and you can help them to do what is right when you are with them.

Choose a child to say a prayer and thank God for always teaching us how to obey.

Teacher Tips

Glue sand onto the path to make it look more realistic.



Jonah Obeys

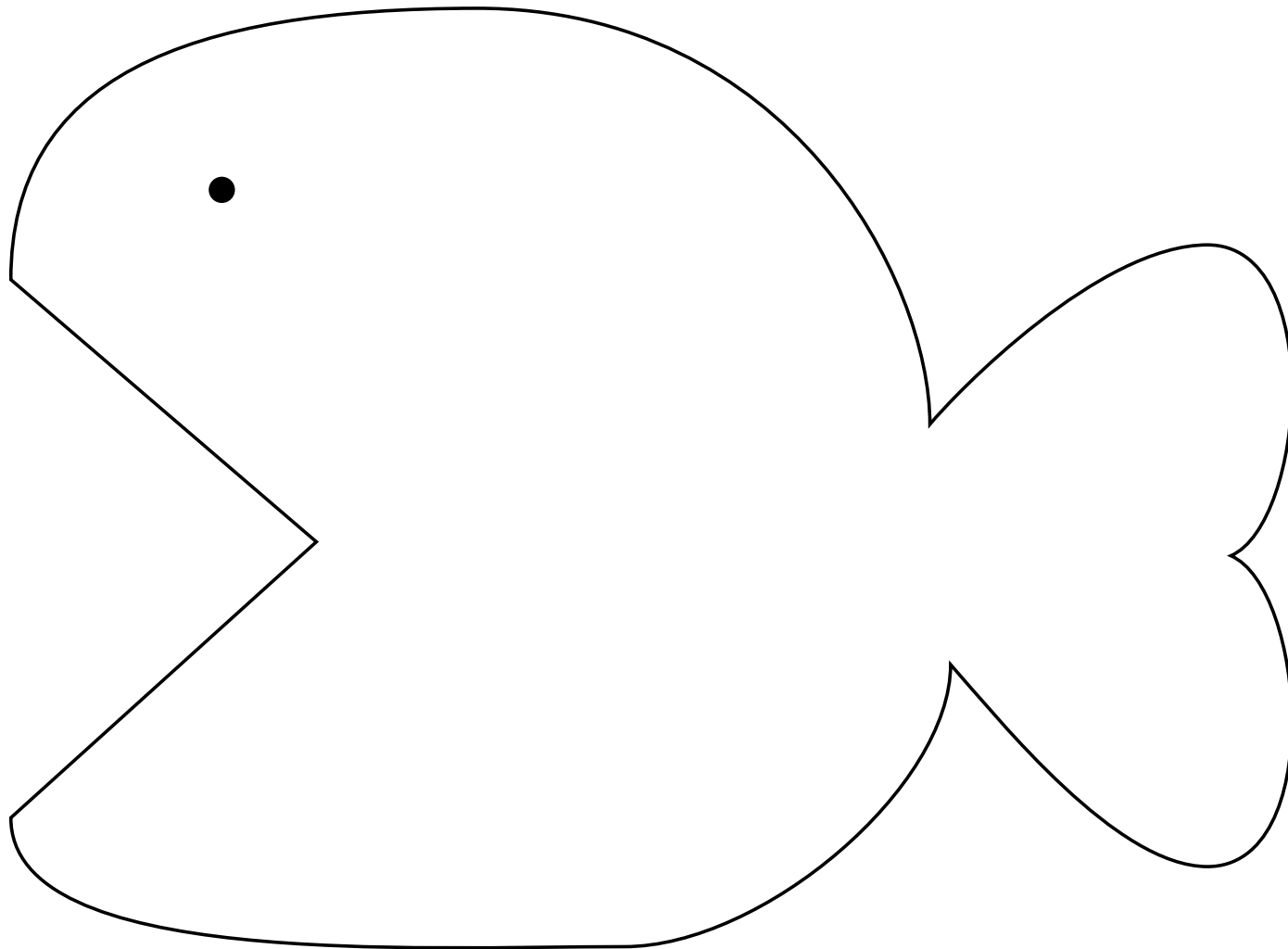

Jonah Obeys

Fish Book-2

The children will create a book of their drawings recounting the story of Jonah.

Materials

For each child:

- book covers from the Preclass Activity
- 4 pieces of white paper
- crayons/markers

For the teacher:

- yarn
- scissors
- marker

Reproducible Pages:

- Page A, 1 copy for the teacher

Preparation

1. Cut out the fish stencil from the copy of Reproducible Page A.
2. Trace and cut out four fish for each child from white paper.
3. Punch two holes in the tail of each fish where indicated on the stencil.
4. Cut two 6" pieces of yarn for each child.
5. Make a model of the craft following the instructions.

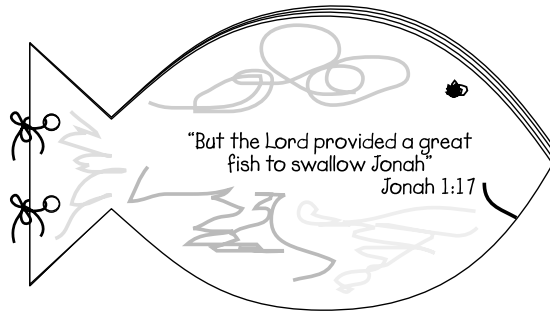

Instructions

1. Give each child the cover to their book from the Preclass Activity and four white fish pages.
2. Have the children stack their pages in between their book covers.
3. Give each child two pieces of yarn and help them thread each piece through a hole in the fish's tail.
4. Loosely tie each piece of yarn.
5. Ask the children to tell you the story of Jonah.
6. Stop the children at four distinct points and have them draw a picture of what they have just recounted on the next page of their books. Here are four examples of pictures that they could draw:
 - Jonah running away to a ship.
 - Jonah inside the fish.
 - Jonah being spit up onto the shore by the fish.
 - Jonah preaching to the Ninevites.

Conclusion

Have the children "read" their stories to each other or to their friends.

Teacher Tips

- Some children may not want to draw because they think they "can't do it." Encourage them to try their best and then encourage them for the work they do.
- Make your drawings simple so those who wish to do so may copy them.
- A child may be sensitive about another child "copying" their ideas for drawing or coloring. Encourage them to share their creativity, as it is a gift to them from God.

CRAFT

Jonah Obeys

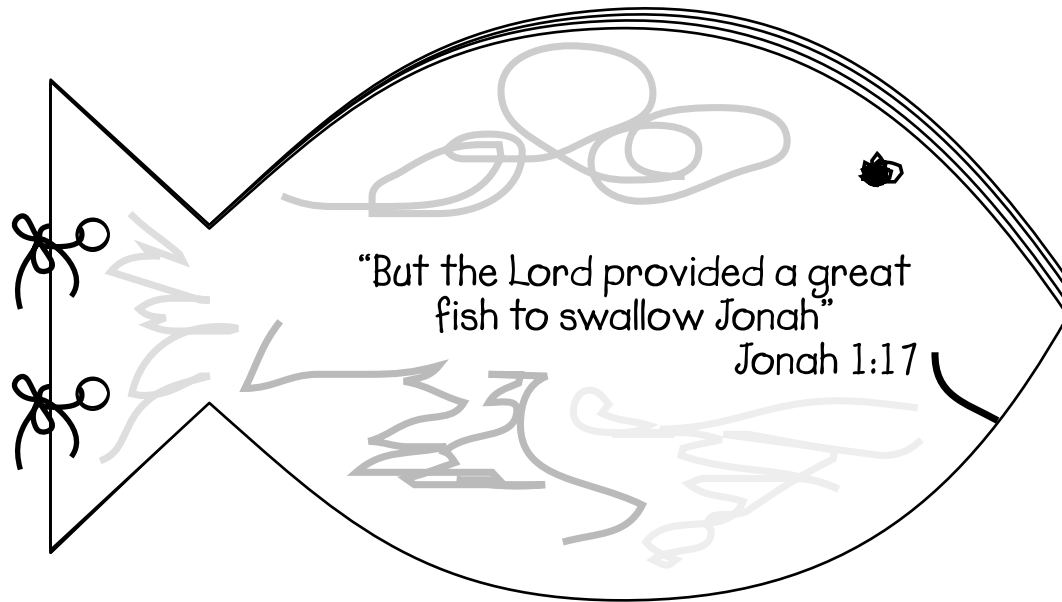

Finished Craft





Pre class



Jonah Obeys

More Heroes of Old

Lesson 2

Lesson Objectives

- The children will thank God for helping them to do what is right.
- The children will state that they can make God happy by repenting if they're doing something wrong.
- The children will draw a picture of one thing that they can do to obey God.

Lesson Text

Jonah 3

Scripture Memory Verse

The Lord provided a great fish to swallow Jonah.

Jonah 1:17

Hide and Seek Containers

The children will make props to be used in the Game Center.

Materials

For each child:

- glue stick

For the teacher:

- 3 large cardboard boxes or dark colored containers (big enough to hide a 4 or 5 year old)
- stickers
- sharp knife
- tissue paper
- construction paper
- scissors
- masking tape or glue

Preparation

1. Cut off both ends of each of the boxes.
2. Cut various shapes from construction paper.
3. Cut the tissue paper into strips.

Instructions

1. Have the children decorate the outsides of the boxes by gluing on the construction paper shapes and tissue paper strips.
2. Give the containers to the Game Center teacher.

Conclusion

Tell the children that the boxes will be used in the Game Center.

Teacher Tips

- Use a plastic container or storage bin.
- If using plastic containers, dark colors will work best as sometimes light colored plastic is transparent.

Lesson Plan

Greeting and Registration

Preclass Activities: Hide and Seek Containers

Welcome and Singing

Centers:

Game: Hide and Seek

Craft: God Leads Me

Life Application: God Directs My Footsteps

NOTE: Be sure to allow sufficient time for a snack.



Hide and Seek

In this game the children will be reminded of the story of Jonah and that we can not hide from God.

Materials

For the teacher:

- 3 boxes from the Preclass Activity

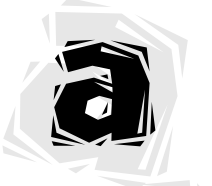

Preparation

Familiarize yourself with the game.



Instructions

1. In our Bible story this week we're learning about Jonah. In the beginning of the story Jonah tried to hide from God. Where did he try to hide? (in a boat) Did God know where he was? (yes) God always knows where we are and what we are doing.
2. Introduce the game to the children. Explain that there are three containers and that a child will hide in one of them while the other children hide their eyes. Then they will try to guess which container the child is in.
3. Choose a child to hide.
4. Have the children hide their eyes while you help a child hide in or under a container.
5. Have the children uncover their eyes and take turns guessing which container the child is hiding in.
6. Continue until all of the children who want to have had a turn to hide.



Conclusion

Sometimes it was hard to find the person who was hiding wasn't it? We didn't always get it on the first try. But did God know where the person was hiding? Yes, every time. God always knows where we are and what we are doing.

Teacher Tips

Do not compel a child to hide if they do not feel comfortable.

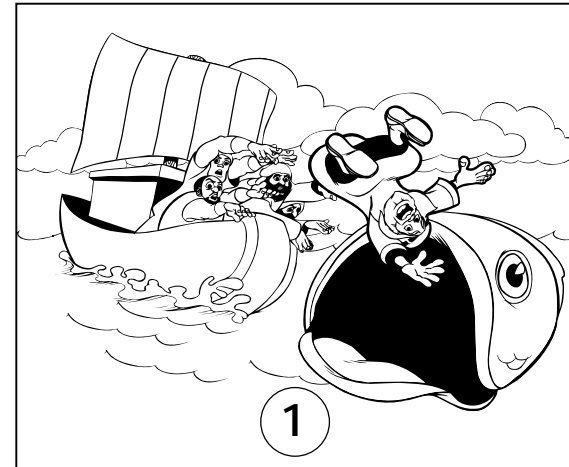



God Leads Me

Jonah walked wherever he needed to go. Today we often go where God wants us to in a car, e.g. to visit the sick, to church or Bible class, to visit a friend, to ask someone to church.

Materials

For each child:

- 1 piece of bright-colored cardstock or poster board, 8½" x 11"
- 2 brass fasteners
- glue

For the teacher:

- 3 pieces of black cardstock or posterboard
- glitter
- marker

Reproducible Pages:

- Page E, 1 copy for the teacher

Preparation

1. Cut out the car stencil and the wheel stencil from the copy of Reproducible Page F.
2. Trace and cut out one car for each child from bright-colored card stock.
3. Write "God leads me to help others." on each car.
4. Trace and cut out two wheels for each child from black cardstock.
5. Punch a hole in the center of each wheel and on the "x" of each car.

Jonah Obeys

More Heroes of Old

Lesson 2

Instructions

1. Talk to the children about Jonah walking to tell the people of Nineveh about God. *Today we don't always walk to different places to help people. Sometimes we ride in cars.*
2. Give each child a car and two wheels. Help the children attach the wheels with the brass fasteners.
3. Have each child decorate the car with markers and crayons.
4. Have each child place some glue and glitter for the headlight and tail light.

Conclusion

While working on the car the children can share about places they have gone to serve God such as: to visit the sick, to go to Bible class, to visit a friend, to invite someone to come to church.

Teacher Tips

Cut out the windows of the cars and have the children glue cellophane or plastic wrap on the cars as windows.

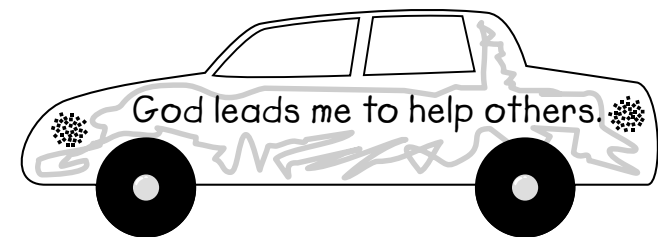

supplement

C
R
A
F
T

Jonah Obeys

More Heroes of Old

Lesson 2

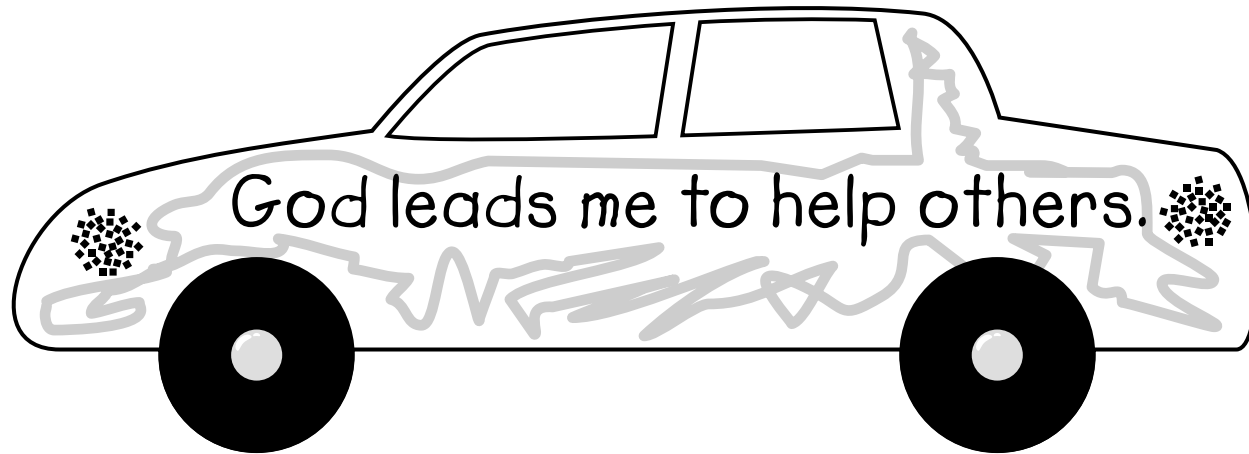

Finished Craft



God Directs My Footsteps

The children will participate in making a mural to illustrate that God directs us and helps us just like he helped Jonah.

Scripture Memory Verse

The Lord provided a great fish to swallow Jonah.
Jonah 1:17

Materials

For each child:

- crayons and markers

For the teacher:

- 1 piece of poster board, 8½" x 11"
- butcher paper, 4'
- scissors
- brown paper bags or brown construction paper

Preparation

1. Trace your foot onto the poster board and cut it out to make a stencil.
2. Trace and cut out one footprint for each child from the brown paper bags. Make both right and left footprints.
3. Write the word "Heaven" at the top right hand corner of the butcher paper and draw clouds around the word.
4. Draw a path from the lower left corner of the butcher paper winding up to "Heaven." Draw flowers along the path.

Instructions

1. Ask the children how God helped Jonah to be obedient. (creating a big storm, having a big fish swallow him) *God wants to help all of us. Sometimes we need different kinds of help. Jonah wasn't listening to God so God did something very different. Did it help Jonah to pay attention? (yes) God wants us all to go to heaven and be with him. If we obey him, we will always be on the right path.*
2. Show the children the path that leads up to heaven.

Jonah Obeys

More Heroes of Old

Lesson 2

3. Ask the children to name some things God tells us to do? (pray, share, be loving, help others, be kind, be happy) Write the list of things that they say along the path.
4. Give each child a footprint and have him draw a picture of himself doing something that God instructs us to do.
5. Have the children glue their footprints onto the path next to the words that correspond with their picture.

Scripture Memory Activity

Work with the children as a group and create hand and body movements to act out the memory verse. Have the children practice it and act it out for the group.

Conclusion

We probably will never be swallowed by a big fish when we are disobedient. But God does want us to obey him and the people He puts in our lives to help us do what is right. God is very kind and he wants us all to be with him in heaven, that is why he gives us our parents and teachers to help us to learn right from wrong.

God can use you to help your friends learn also. You can tell them the story about Jonah and you can help them to do what is right when you are with them.

Choose a child to say a prayer and thank God for always teaching us how to obey.

Teacher Tips

Glue sand onto the path to make it look more realistic.



Jonah Obays

More Heroes of Old

Lesson 2

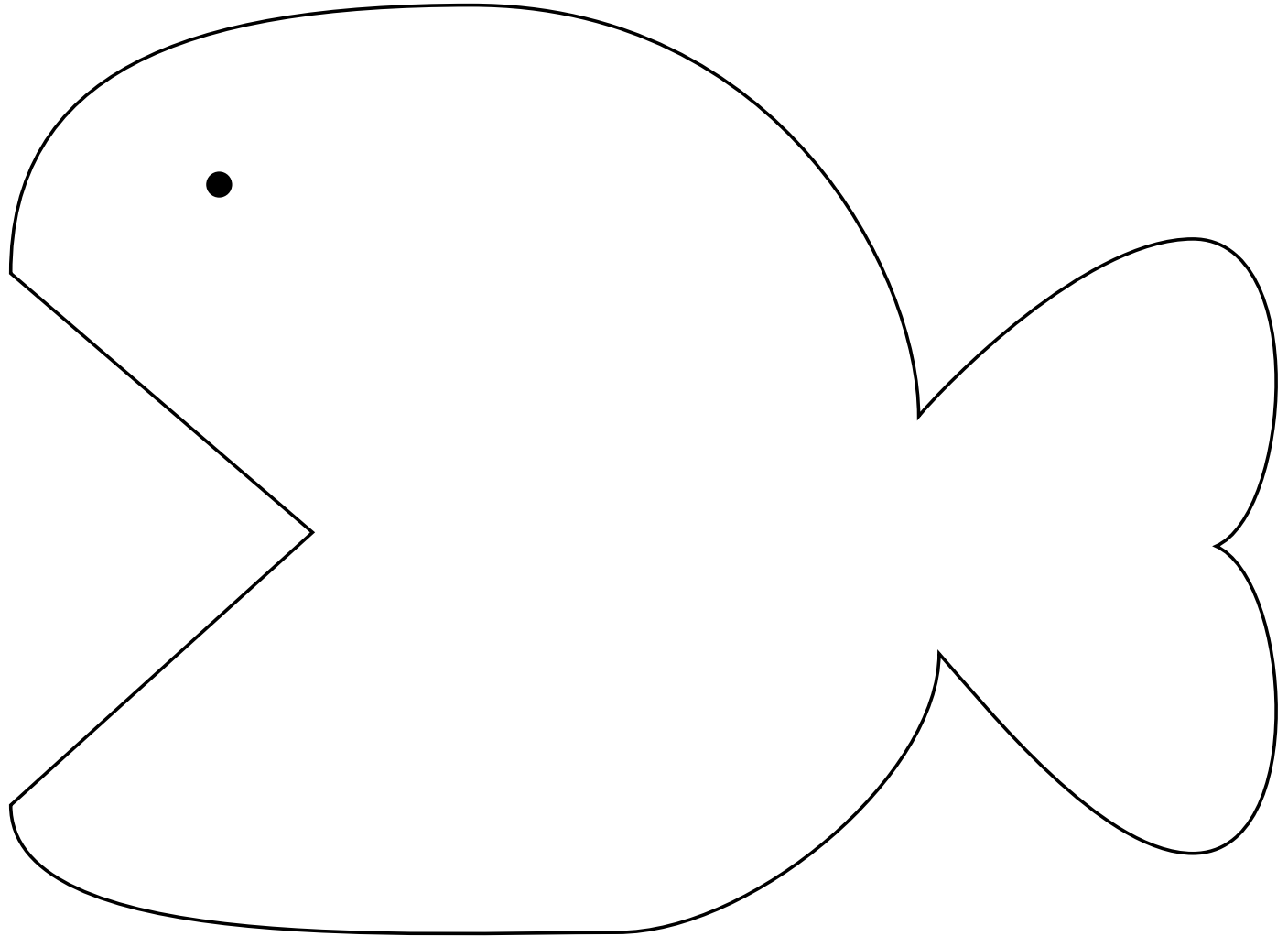

Core/Preclass and Core/Craft

1 copy for the teacher

Read-Observe-Write

Page

A

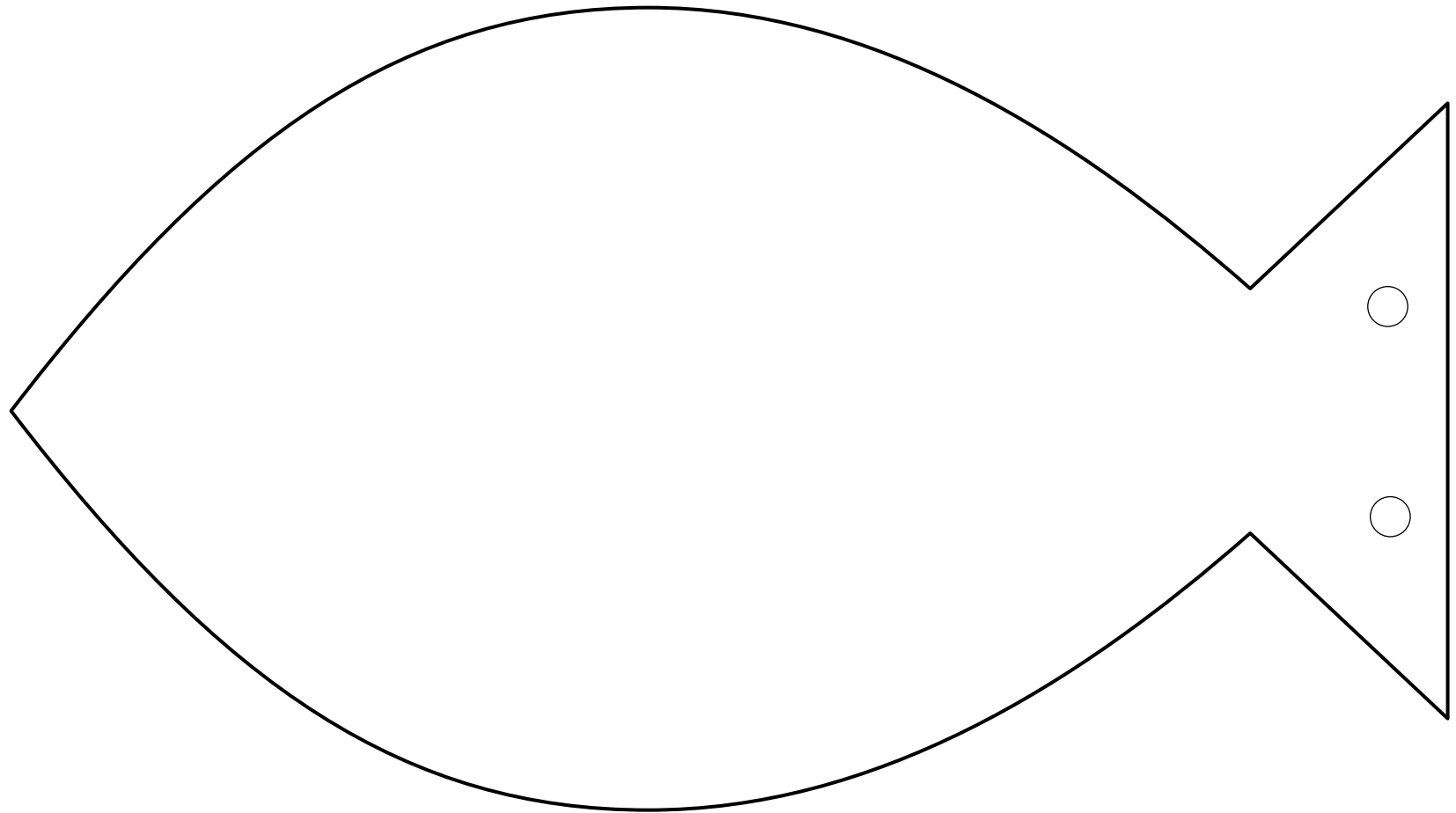

fish stencil



Core/Bible Story
1 copy for the teacher

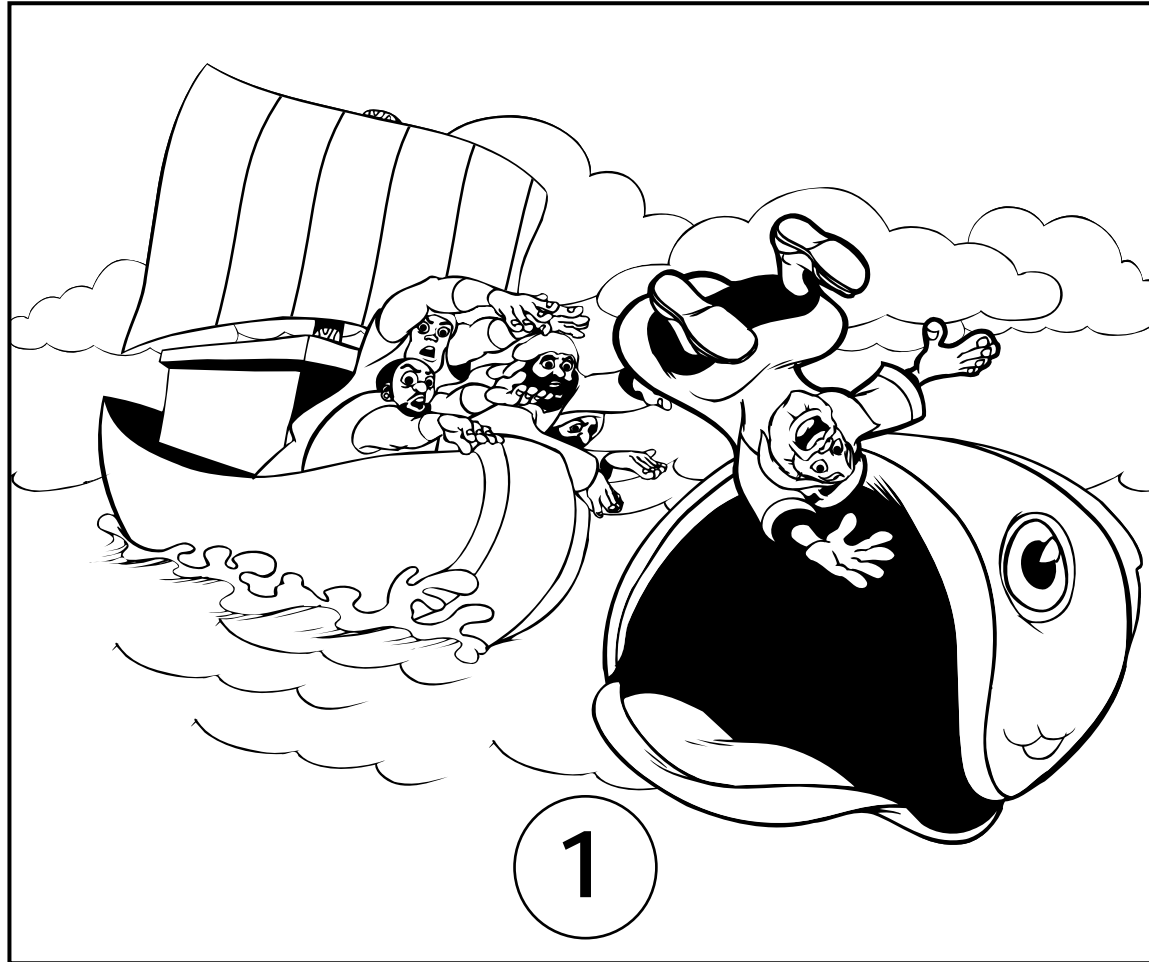

Core/Bible Story
1 copy for the teacher



Core/Bible Story

1 copy for the teacher

READ-OBEDIENCE

Page

D

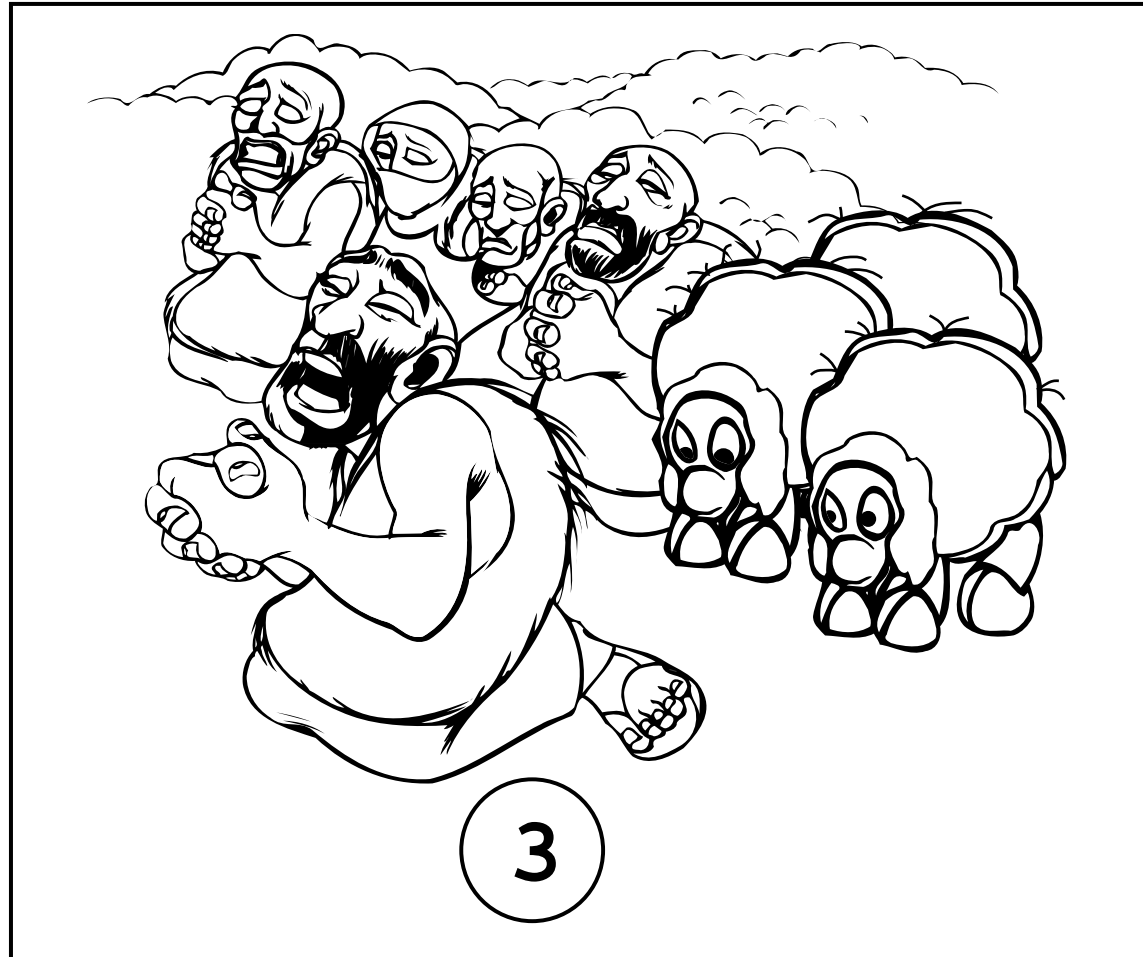

Supplement/Craft

1 copy for the teacher

W
E
B
E
E
O
T
H
E
R

Page

E

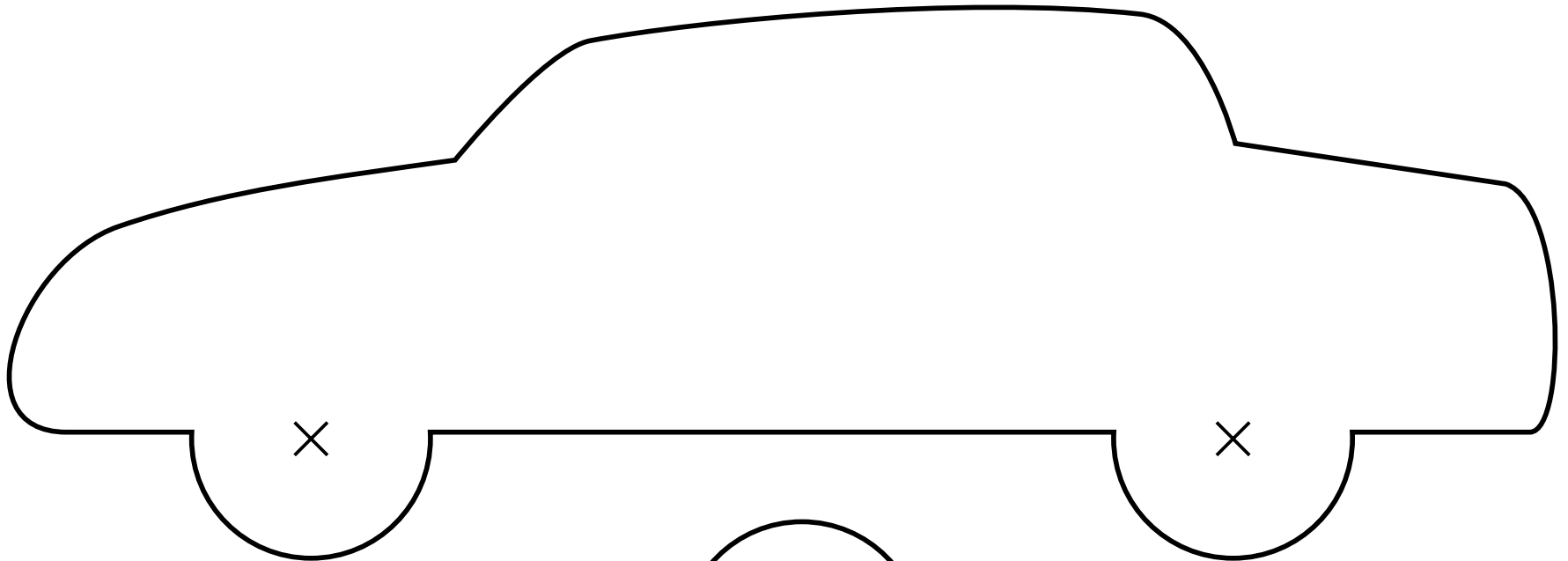

car stencil

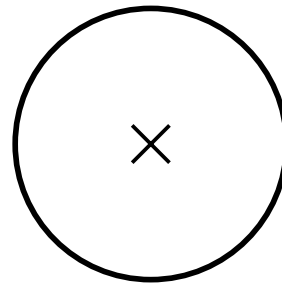

wheel stencil