

He Shared His Lunch

Lesson Objectives

- The children will state that Jesus fed five thousand people with five loaves and two fish.
- The children will learn positive things about sharing.
- The children will select something that they would like to share.

Lesson Text

John 6:1-15

Scripture Memory Verse

This amazed everyone and they praised God saying, "We have never seen anything like this!"

Mark 2:12

Lesson Plan

Greeting and Registration

Preclass Activity: Mural of Five Thousand

Welcome and Singing

Centers:

Bible Story: Jesus Feeds Five Thousand

Life Application: To Share or Not to Share

Craft: The Shared Fish

NOTE: Be sure to allow sufficient time for a snack.



Pre
class



He Shared His Lunch

Giving
Lesson 1

Mural of Five Thousand

The children will create a mural that will be used in the Bible story.

Materials

For each child:

- plain white paper
- scissors
- markers or crayons
- glue stick

For the teacher:

- magazines
- scissors
- newsprint or poster board
- tape

Preparation

1. Cut out pictures of "crowds" from magazines (use happy people vs. scary or sad people). Cut several pictures for each child.
2. Tape the newsprint onto the wall where the children will work or place it on a large flat surface.

Instructions

1. Tell the children, *Our story today is about a crowd of five thousand people who followed Jesus. Can you imagine five thousand people? What is the biggest crowd of people you have ever seen? Suggest a parade, a circus, a market or a large church service. That's about how many people there were with Jesus! Let's make a picture that has a lot of people, maybe even five thousand people in it! Then, we can use it for the Bible story.*
2. Have the children select magazine pictures of people to glue onto the newsprint.
3. Have each child draw a picture of themselves on white paper. Have them cut out the picture and glue it to the mural.
4. Have the children sign their name in the area of the mural where they worked.
5. Give the mural to the Bible story teacher.

Teacher Tips

- If children finish early have them add more details to the mural (sky, clouds, trees, etc.)
- Be sure to emphasize the fact that five thousand is a lot of people.



He Shared His Lunch

Jesus Feeds Five Thousand

The children will hear the story of Jesus feeding the five thousand with a young boy's small amount food.

Lesson Text

John 6:1-15

Materials

For the teacher:

- a blanket for everyone to sit on
- the mural from the Preclass Activity
- a picnic basket
- a napkin (paper or cloth)
- 5 small bread rolls
- a package of fish shaped crackers
- a few pieces of bread, broken into small pieces
- 2 pieces of construction paper
- scissors
- crayons or markers

Reproducible Pages:

- Page A, 1 copy for the teacher

Preparation

1. Cut out two large fish shapes from construction paper.
2. Place several fish shaped crackers and broken pieces of bread in the bottom of the picnic basket.
3. Cover the basket with a napkin and place the five bread rolls and the two paper fish shapes on top of the napkin.
4. Cut out and color the picture of Jesus from the copy of Reproducible Page A.
5. Tape the mural to a wall or table in the Bible Story area.

Instructions

Have the children help you spread the blanket on the floor near the mural. *Let's pretend that we are on a mountainside with all of these people in the mural.*

Give the basket to a child in the group and tell the child to hold onto it but not to open it.

Open your Bible to John 6 and begin to tell the story. *The Bible says that a crowd of five thousand people followed Jesus when he*

went up on a mountainside. Point to the mural. Place the picture of Jesus on the mural.

When Jesus sat down with his disciples, he looked and saw that people were following him. It was close to dinnertime and the people were getting very hungry. Jesus knew that the people were hungry and he wanted to help them. This is what Jesus said to Philip: When Jesus looked up and saw a great crowd coming toward him, he said to Philip, "Where shall we buy bread for these people to eat?" Philip answered him, "Eight months' wages would not buy enough bread for each one to have a bite!" (John 6:5,7)

Philip knew they didn't have enough money to buy food for all of the people that were there! Andrew, a friend of Jesus, wanted to help. He said to Jesus, "Here is a boy with five small barley loaves and two small fish, but how far will they go among so many?" (John 6:8-9)

Say to the child with the basket: *Come here little boy. Will you share your lunch with us and all of these people?* Instruct the child to answer yes. *What do you have in your basket to share with everyone?* Help the child to take out the two fish and the 5 small loaves.

Say to the children: *Look we have one, two, three, four, five loaves of bread and one, two fish. Thank you so much for sharing your lunch with us! Point to the mural. There must be five thousand people here! Will this be enough food to feed all these people? (No) Let's find out what Jesus did when he didn't have enough food for everyone.*

Jesus said, "Have the people sit down." There was plenty of grass in that place, and the men sat down, about five thousand of them. Jesus then took the loaves, gave thanks, and distributed to those who were seated as much as they wanted. He did the same with the fish. (John 6:10-11)

Explain to the children: *After Jesus thanked God for the food, the disciples started serving the food to all of the people. They kept giving out more and more and more food until everyone was full! Do you know how that happened? God made five loaves and two fish feed all five thousand people that were there. He made a miracle!*

Let's pretend that we are with Jesus. First, Jesus told them to sit down. Let's all sit down. Then, Jesus took the food and gave thanks, so what should we do? Let's give thanks for the food just like Jesus did.



He Shared His Lunch

While you are praying, remove the napkin from the basket to uncover the fish shaped crackers and bread. *What happened after Jesus gave thanks? (When they served the food there was enough for everybody!) Let the children look at all of the food in the basket. Look! We have enough food for everyone now! Let's share the food in the basket just like Jesus did. Isn't that amazing that all five thousand people were able to have as much food as they wanted and it never ran out?*

NOTE: Save the mural for the Unit 7 Lesson 2, Bible Story.

Conclusion

While the children are eating the fish crackers, encourage them to describe the miracle that they just learned about. Ask them the following questions:

What was the miracle that Jesus did? (multiplied the food to feed all of the people that were following him)

Why did he feed the people? (they were hungry)

How many people did he feed? (five thousand)

Where did Jesus get the food? (a little boy shared his food)

Who shared in this story? (the little boy)

Because the little boy in this story decided to share his food, all of the people were able to eat! God loves it when we share.



Teacher Tips

- IMPORTANT: Be sure that none of the children have allergies to any of the snacks you may serve during this activity. Ask the parents at registration if their child has any food intolerance or food allergies.
- Be sure to practice telling the story, anticipating the children's participation.



To Share or Not to Share

This activity will help the children to see the good things that happen when we share.

Scripture Memory Verse

This amazed everyone and they praised God saying, "We have never seen anything like this!"

Mark 2:12

Materials

For each child:

- 1 small plastic bag

For the teacher:

- popcorn (about one cup for each child)
- a basket

Preparation

Fill one small bag of popcorn for each child.

Instructions

1. Place the bags of popcorn in the basket next to you where the children can see it.
2. Review the Bible story: *In our story today Jesus fed lots and lots of people with just two fish and five loaves of bread? A young boy gave Jesus his food so that it could be shared with the crowd. Because the young boy shared, everyone was able to eat. What would have happened if the boy did not share his food? (No one else would have had anything to eat!) When we share, it means that we let someone else use or have something that we have. What are some things that you could share with a friend? (toys, food, snacks, crayons.) That's right, all of us have something we can share. Can you see anything that I could share with all of you right now? The popcorn? But if I share all of my popcorn, I might not have any left for myself! Do you think the little boy worried about not having enough for himself?*
3. Give each child a bag of popcorn. *I like to share, it makes me happy. How do you feel when someone shares with you? How do you feel when you share with others? Do you feel happy, good, excited, important?*

4. Help the children to see the good that comes out of sharing. *Sharing makes other people happy, it makes us happy, and it makes God happy. Sometimes it is hard to share. Can you think of some things that might be hard to share? (a favorite toy, the last cookie, sharing our Mommy with our new baby brother or sister) Help them to identify how they feel when someone shares with them. Talk about how we feel when someone does not share with us. Tell them that they can bring their popcorn home and share it with their family.*

Scripture Memory Activity

Divide the children into two groups, both groups facing the mural of the five thousand.

Walk up to the mural with the basket in your hand and say: *It's a miracle! Jesus just fed that whole crowd of five thousand people with only a small amount of food.*

Have one group say: *"This amazed everyone and they praised God saying..."*

Have the other group say: *"We have never seen anything like this."*

Repeat the scripture a few times then have the groups switch verses and repeat the scripture a few more times.

Conclusion

Ask the children: *What are some good things that happen when we share with someone? (It makes them happy, they may become a friend) How does it make you feel to share with someone? How does it make you feel when someone shares with you? God also wants us to share what we are learning in the Bible with others. Who can tell us what they learned from the Bible today? Who else can you share that with?*

Say a prayer and ask God to help you and the children to be great at sharing.

Teacher Tips

- Pretzels, potato chips, mini cookies or crackers may be used in place of popcorn.
- Use zip lock bags or ties to avoid spills.
- Bring extra snacks and have the children share with the other teachers in the class.



He Shared His Lunch

This amazed everyone and they praised God saying,
“We have never seen anything like this!”

Mark 2:12



He Shared His Lunch

The Shared Fish

The children will make a fish to remind them of the fish the little boy shared with Jesus.

Materials

For each child:

- one paper lunch bag
- glue
- crayons and markers

For the teacher:

- scissors
- construction paper
- yarn
- newspaper
- hole punch
- marker
- tissue paper (optional)

Reproducible Pages:

- Page B, 1 copy for the teacher
- Page C, 1 copy for every four children

Preparation

1. Cut out the eye, mouth and fin stencils from the copy of Reproducible Page B.
2. Prepare the following fish parts for each child. See Figure A.
 - A. Trace and cut out two fins, two eyes and one mouth from construction paper for each child.
 - B. Using a black marker draw a large circle in the center of each of the eyes.
 - C. Using a black marker draw a small oval in the center of each mouth.
3. Cut out the text boxes from the copies of Reproducible Page C.
4. Cut two, 8" pieces of yarn for each child.
5. Tear the newspaper into strips.

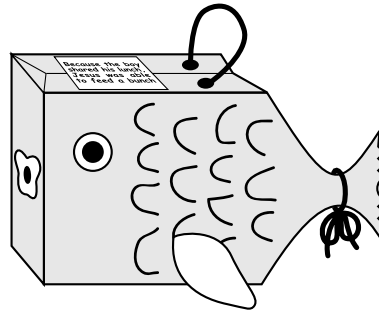

6. Punch two holes through each paper bag as follows:
 - A. Lay each bag on its side.
 - B. Using your finger, push the bag from the inside so that the side crease bulges outward.
 - C. Pinch and hold the side crease in the fingers of your other hand, and then punch a hole approximately 1/2" from the side crease.
 - D. The paper bag should now have two holes, one on either side of the crease, as shown in Figure B.
7. Make a model of the craft following the instructions.

Instructions

1. Introduce the craft as follows: *The Bible story today is about a boy who shared his food with Jesus and his friends. Because the boy shared, Jesus was able to feed a crowd of five thousand people! One of the foods that the boy shared was fish. Today for our craft we will make a fish like this! Show the children your model of the craft.*
2. Give the children each a paper bag and have them color their bags with crayons and markers.
3. Have each child glue a text box onto the side of the paper bag with the punched holes. See Figure C.
4. Have the children decorate their fish as shown in Figure D:
 - A. Have the children glue an eye and a fin onto the front and back of their bags.
 - B. Have the children glue the mouth to the bottom of the bag.
5. Have the children stuff the newspaper strips into the bag.
6. Help the children tie the string to finish their fish as follows. See Figure E.
 - A. Help them tie the bag near the opening with a piece of yarn.
 - B. Fan out the end of the paper bag so it looks like a tail.
 - C. Thread a piece of yarn through the two holes in the top of the fish. Tie the ends of the yarn together making a holder.

Conclusion

You can hang this fish in your room to remind you of the boy who shared his food. What happened when he shared his fish with Jesus? Jesus was able to feed five thousand people!

He Shared His Lunch

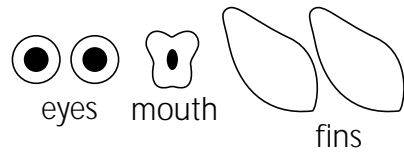

Figure A

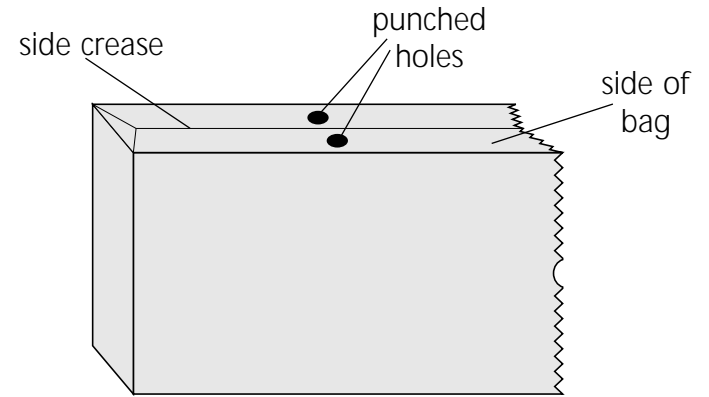

Figure B

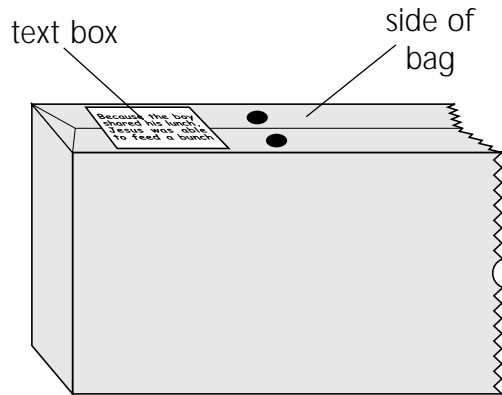

Figure C

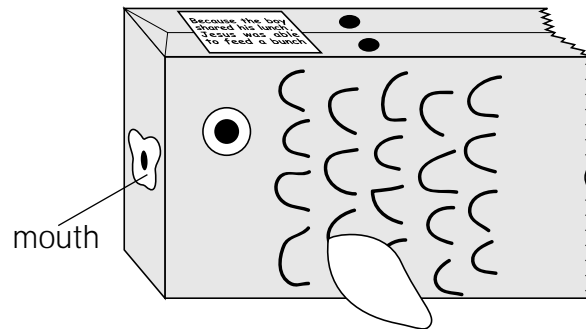

Figure D

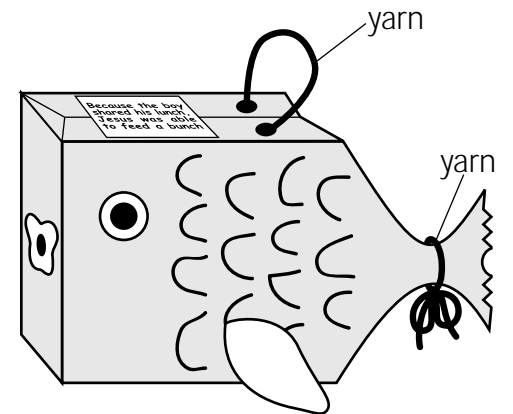

Figure E



He Shared His Lunch

Lesson Objectives

- The children will state that Jesus fed five thousand people with five loaves and two fish.
- The children will learn positive things about sharing.
- The children will select something that they would like to share.

Lesson Text

John 6:1-15

Scripture Memory Verse

This amazed everyone and they praised God saying, We have never seen anything like this!"

Mark 2:12

Fill the Basket-1

The children will make props to be used in the Game center.

Materials

For each child:

- markers and crayons
- one piece of red construction paper

For the teacher:

- scissors
- gray construction paper
- brown construction paper
- white paper

Reproducible Pages:

- Page D, 1 copy for the teacher

Lesson Plan

Greeting and Registration

Preclass Activity: Fill the Basket-1

Welcome and Singing

Centers:

Game: Fill the Basket-2

Craft: The Sharing Basket

Life Application: To Share or Not to Share

NOTE: Be sure to allow sufficient time for a snack.

Preparation

1. Cut out the loaf and fish stencils from the copy of Reproducible Page D.
2. Trace and cut out two fish for each child from gray construction paper.
3. Trace and cut out five loaves for each child from brown construction paper.
4. Cut out one square, 5", for each child from white paper.
5. On each piece of red construction paper write, "I will share."

Instructions

1. Give each child five loaves of bread and two fish.
2. Have the children color the fish and loaves.
3. On the white paper, have each child draw something that they would like to share.
4. Have the children glue each picture to a piece of red construction paper.
5. Give the loaves and fish to the Game teacher.



Fill the Basket-2

The children will play a game that will remind them of the miracle of Jesus feeding the five thousand.

Materials

For the teacher:

- loaves and fish from the Preclass Activity
- two small baskets

Preparation

Place five loaves and two fish in each basket.

Instructions

1. Place the two baskets at the far end of the center area, a few feet apart from each other. Explain to the children that each basket represents the lunch of the boy who shared with Jesus.
2. Place the remaining loaves and fish in two piles, each pile about three feet to the side of each basket.
3. Divide the children into two groups.
4. Line each team up single file, ten feet from the baskets.
5. At your signal, the first child in each line must walk to his team's basket, pick up one item, and put it in the pile next to his basket.
6. The child then must tag the next player in line. Continue until all the food from the basket is gone.
7. When the basket is empty, the next person in line goes to the pile, takes one item, and returns it to the basket.
8. The child must tag the next person in line. Continue until all of the food from the pile is in the basket.
9. The first team to fill their basket wins.

Conclusion

Explain to the children that the basket of food at the beginning of the game represented the boy's lunch. Now, at the end of the game, it contains much more food. *That is just what happened when Jesus fed all the people. After everyone was fed, there were many baskets of food left over. When we pray to God, he will give us what we need, and sometimes he gives us even more than we need.*

Teacher Tips

As you explain the race, have the first child demonstrate the game as the other children watch.

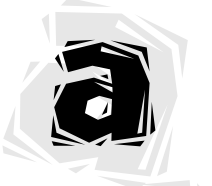
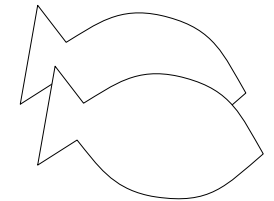
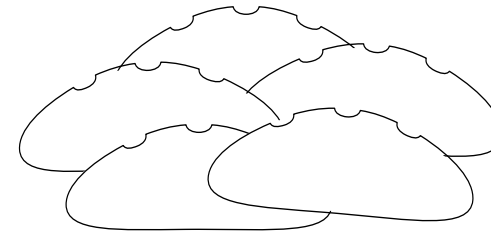



The Sharing Basket

The children will make a basket of bread and fish to remind them of the miracle of Jesus feeding the five thousand.

Materials

For each child:

- 1 small paper lunch bag
- crayons or markers
- glue stick

For the teacher:

- scissors
- tape
- old-fashioned oatmeal
- brown construction paper
- gray construction paper
- aluminum foil
- black marker
- stapler

Reproducible Pages:

- Page E, 1 copy for the teacher

Preparation

1. Prepare a "basket" for each child as follows:
 - A. Cut off the top half of each bag. See Figure A.
 - B. Cut a 8" x 2" strip from the left over top half of each bag to make a handle.
 - C. Tape a handle securely onto each basket. See Figure B.
 - D. Print "_____ shares!" on the side of each bag.
2. Prepare the fish and loaves as follows:
 - A. Cut out the loaf and fish stencils from the copies of Reproducible Page E.
 - B. Trace and cut out five loaves from brown construction paper for each child.
 - C. Trace and cut out two fish from gray construction paper for each child.
 - D. Cut out four 1/2" squares from aluminum foil for each child.
 - E. Place two fish, four aluminum foil squares and four loaves into a basket for each child.
3. Make a model of the craft following the instructions.

Instructions

1. Introduce the craft as follows: *Once Jesus helped a boy share his lunch with a large crowd of people. Show the children your basket. Take out the two fish and five loaves. Because the boy shared, five thousand people were able to eat! Today we are going to make a basket just like the boy's basket!*
2. Give each child a basket with the fish and loaves inside of it.
3. Have the children glue oatmeal to each loaf.
4. Give each child two fish.
5. Give each child four squares of aluminum foil. Have them glue these to both sides of their fish.
6. Have the children put their loaves and fish into their baskets.
7. Have the children write their names on their baskets in the space provided.
8. Have the children color their baskets.

Conclusion

Let the children take turns retelling the story of Jesus feeding the five thousand using their baskets.

Teacher Tips

Instead of paper strips for the handles try wide ribbon.

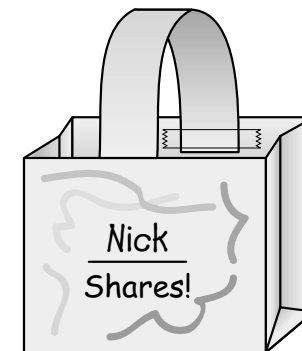
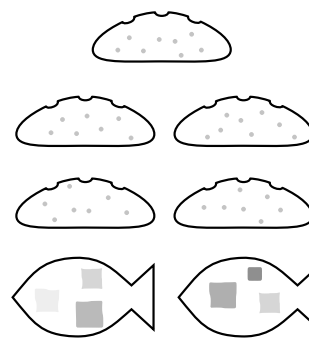

He Shared His Lunch

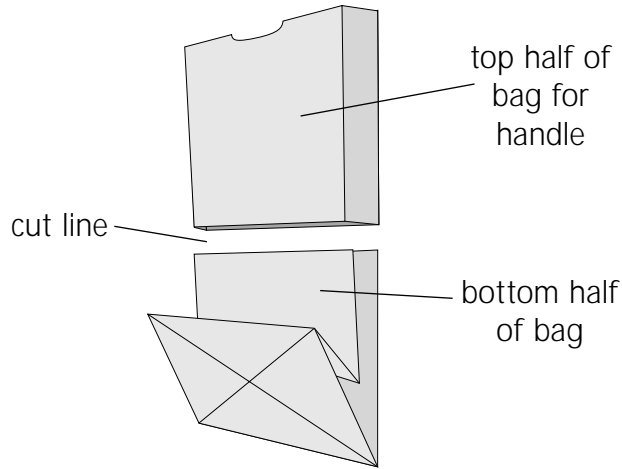

Figure A

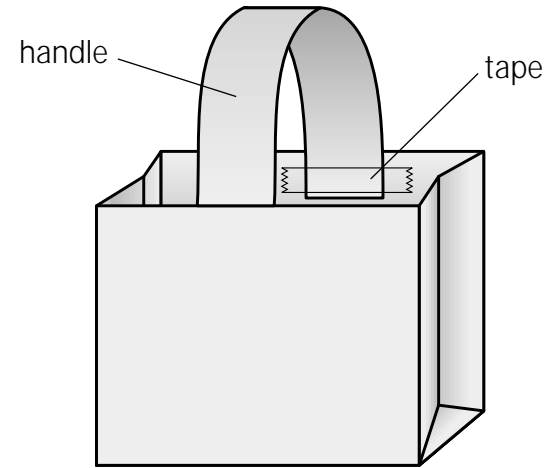
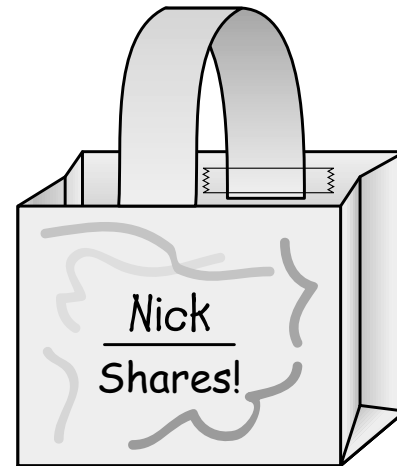
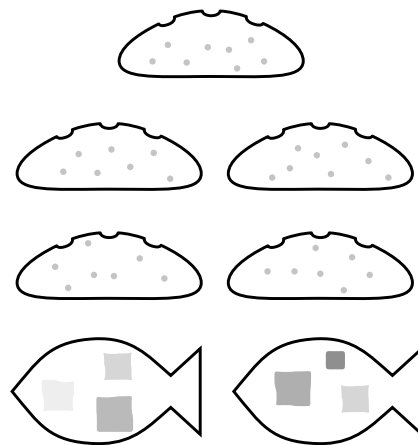

Figure B



Finished Craft

He Shared His Lunch

To Share or Not to Share

This activity will help the children to see the good things that happen when we share.

Scripture Memory Verse

This amazed everyone and they praised God saying, "We have never seen anything like this!"

Mark 2:12

Materials

For each child:

- 1 small plastic bag

For the teacher:

- popcorn (about one cup for each child)
- a basket

Preparation

Fill one small bag of popcorn for each child.

Instructions

1. Place the bags of popcorn in the basket next to you where the children can see it.
2. Review the Bible story: *In our story today Jesus fed lots and lots of people with just two fish and five loaves of bread? A young boy gave Jesus his food so that it could be shared with the crowd. Because the young boy shared, everyone was able to eat.*

What would have happened if the boy did not share his food? (No one else would have had anything to eat!) When we share, it means that we let someone else use or have something that we have. What are some things that you could share with a friend? (toys, food, snacks, crayons.) That's right, all of us have something we can share. Can you see anything that I could share with all of you right now? The popcorn? But if I share all of my popcorn, I might not have any left for myself! Do you think the little boy worried about not having enough for himself?

3. Give each child a bag of popcorn. *I like to share, it makes me happy. How do you feel when someone shares with you? How do you feel when you share with others? Do you feel happy, good, excited, important?*

4. Help the children to see the good that comes out of sharing. *Sharing makes other people happy, it makes us happy, and it makes God happy. Sometimes it is hard to share. Can you think of some things that might be hard to share? (a favorite toy, the last cookie, sharing our Mommy with our new baby brother or sister) Help them to identify how they feel when someone shares with them. Talk about how we feel when someone does not share with us. Tell them that they can bring their popcorn home and share it with their family.*

Scripture Memory Activity

Divide the children into two groups, both groups facing the mural of the five thousand.

Walk up to the mural with the basket in your hand and say: *It's a miracle! Jesus just fed that whole crowd of five thousand people with only a small amount of food.*

Have one group say: *"This amazed everyone and they praised God saying..."*

Have the other group say: *"We have never seen anything like this."*

Repeat the scripture a few times then have the groups switch verses and repeat the scripture a few more times.

Conclusion

Ask the children: *What are some good things that happen when we share with someone? (It makes them happy, they may become a friend) How does it make you feel to share with someone? How does it make you feel when someone shares with you? God also wants us to share what we are learning in the Bible with others. Who can tell us what they learned from the Bible today? Who else can you share that with?*

Say a prayer and ask God to help you and the children to be great at sharing.

Teacher Tips

- Pretzels, potato chips, mini cookies or crackers may be used in place of popcorn.
- Use zip lock bags or ties to avoid spills.
- Bring extra snacks and have the children share with the other teachers in the class.



He Shared His Lunch

This amazed everyone and they praised God saying,
“We have never seen anything like this!”

Mark 2:12



Core/Bible Story

1 copy for the teacher



Read Bible

Page

A



4 and 5 Year Olds

Core/Craft
1 copy for the teacher

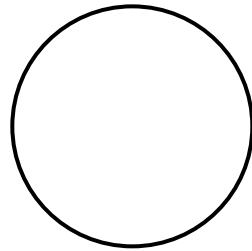

eye stencil

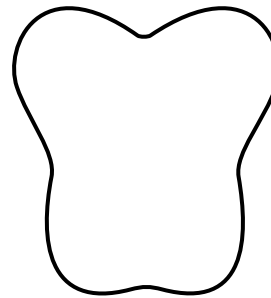

mouth stencil

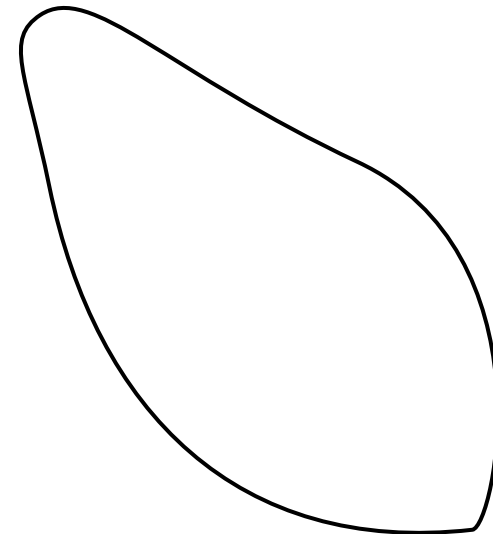

fin stencil

A-B-C-D-E-F-G-H-I-J-K-L-M-N-O-P-Q-R

Page

B



Core/Craft

1 copy for every four children

R
A
D
I
C
A
L
B
I
B
L
E
C

Page

C

Because the boy
shared his lunch,
Jesus was able
to feed a bunch.

Because the boy
shared his lunch,
Jesus was able
to feed a bunch.

text boxes

Because the boy
shared his lunch,
Jesus was able
to feed a bunch.

Because the boy
shared his lunch,
Jesus was able
to feed a bunch.



Supplement/Preclass

1 copy for the teacher

Discipleship

Page

D

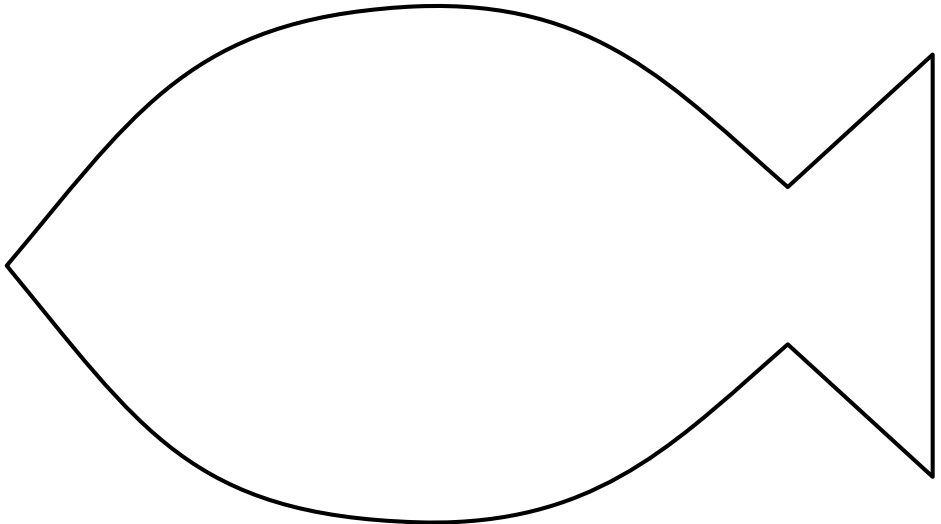

fish stencil

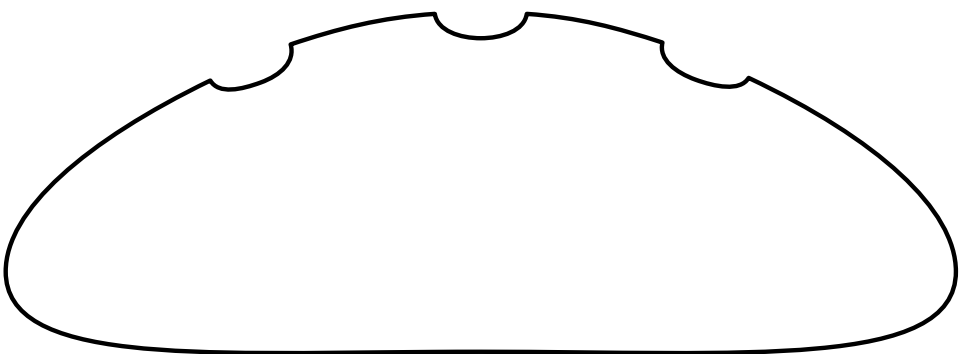

loaf stencil



Supplement/Craft

1 copy for the teacher

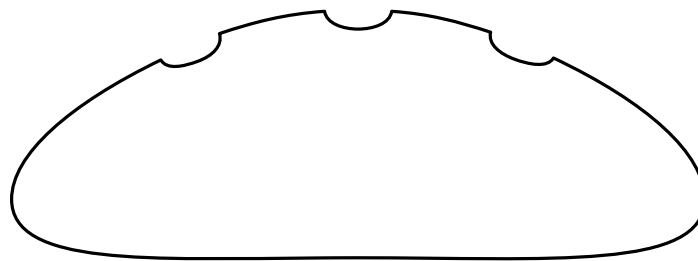

loaf stencil

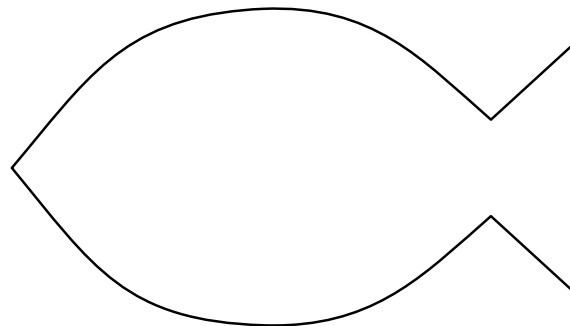

fish stencil

W
A
S
E
E
D
S
O
F
F
A
I
T
H

Page
E

