

I Am Thankful

Thankfulness
Lesson 3

Lesson Objectives

- When asked who had the coat of many colors, the children will answer "Joseph."
- The children will thank their parents for taking care of them.
- The children will thank God for taking care of them.

Bible Story Text

Genesis 37:2a, 3b

Bible Truth

Give thanks to God.
(Psalm 136:26)

Lesson Plan

Greeting and Registration

Preclass Activity: Preclass Centers

Welcome and Singing

Centers:

Bible Story: Joseph's Coat

Life Application: Lesli Gets a Present

Craft: Coat of Many Colors

NOTE: Be sure to allow sufficient time for a snack.



I Am Thankful

Preclass Centers

As the children arrive, guide them to a preclass center. Have no more than six children at each center.

Materials

Use the materials previously selected for this unit's preclass centers.

Preparation

1. Be sure to check the condition of the materials selected for this unit's preclass centers prior to set up. Replace any broken toys, or puzzles with missing pieces as necessary.
2. Set up the centers before the children come into the classroom.
3. Assign a teacher to each center and have the teachers stay in those centers until the singing begins.

Instructions

Guide the play in each center reinforcing the unit theme.

Teacher Tips

- **IMPORTANT:** Do not allow any small toys in the classroom. First check all toys for size. You can obtain a "safety cylinder" from a pediatrician. Any object that can fit into the cylinder is too small and could cause a child to choke.
- Be involved in the group play and offer guidance as needed.
- Wear comfortable clothes suitable for sitting on the floor.
- Smile! Be childlike in heart and alert in mind.

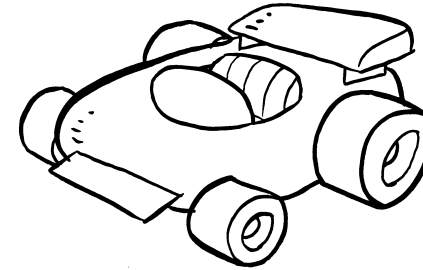
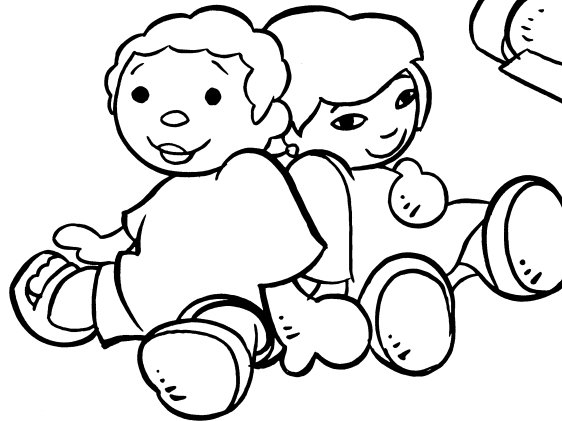
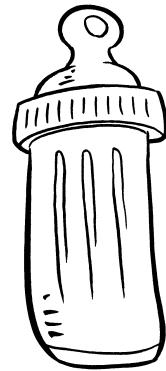

I Am Thankful

Joseph's Coat

The children will hear the story of Joseph's coat.

Bible Story Text

Genesis 37:2a, 3b

Materials

For the teacher:

- Bible
- felt board with a black background
- scissors
- markers
- tape
- clear contact paper or laminate
- construction paper, a different color for each child in the center

Reproducible Pages:

- Page A, 1 copy for the teacher
- Page B, 1 copy for the teacher

Preparation

1. If you do not have a felt board, one can be easily made with a piece of foam board, purchased at a craft, office or art supply store. Cut the board to approximately 11" x 17". Cover the board with a piece of black felt, overlapping the material with two-sided tape on the back.
2. Cut out, color and laminate the figures from the copies of Reproducible Pages A and B.
3. Roll a piece of tape to stick to the back of each figure.
4. Cut each piece of construction paper in half.
5. Familiarize yourself with the Bible Story. Practice telling the story using the flannel board figures.

A Present

Open the Bible to Genesis. *The Bible says there was once a daddy named Jacob. Put the Jacob figure on the felt board. He had a little boy named Joseph. Put the Joseph figure on the felt board. Joseph loved and obeyed his daddy. "Joseph, please go out and take care of the sheep," his daddy said. "OK, Daddy," said Joseph.*

Remove Jacob. Add the sheep, pond and grass to the felt board. *Joseph took the sheep to eat some grass. Move the sheep over to the grass. Then he took the sheep to a pond to get a drink. Move the*

sheep over to the pond. *Joseph knew it was time to go home. "Come on, sheep," he said. The sheep followed him home. Remove the grass and water. Make the sheep follow Joseph. Remove the sheep.*

Add Jacob to the felt board. *When Joseph got home, his daddy said, "Thank you, Joseph. You did a great job with the sheep. I have a present for you." Joseph was so excited! His daddy wanted to give him a present! Ask the children, Who likes to get presents? What do you think Joseph's daddy was going to give him? Let the children respond. Tell them their ideas would make great gifts. It was a beautiful new coat! (Genesis 37:3b) Add the coat onto the Joseph figure.*

Joseph's coat had many bright colors on it. He loved the bright colors! Hold the felt board close to the children and ask each child to point to a color. As the child points to a color, say: Do you know what color that is? That color is Red! Continue until each child has had a turn. Joseph loved his new coat. What do you think he said to his daddy? He said, "Thank you, Daddy! Thank you for my new coat."

Hold the felt board with Jacob, Joseph, and Joseph's new coat on it and sing "Joseph's Coat" from the Unit 12 Song Sheet.

NOTE: Save the felt board figures for the Unit 12 Lesson 4, Bible story.

Conclusion

Give each child a half of a piece of construction paper and put the matching halves on the floor in front of the children.

Let's pretend you want to make a coat the color that you are holding in your hand. Lydia, can you find the same color on the floor? Very good! Do you know what color that is? That color is yellow! Can everyone say "yellow"? Lydia can make a yellow coat. Repeat this with each of the children.

Show the felt board with the figures on it and sing Joseph's Coat one more time. Ask the children, *What do you say when someone gives you something? Right! You say, "Thank you!"*

Who had the coat of many colors? Yes, Joseph.

Teacher Tips

- Encourage the children as they try to name the colors. Many of them won't know all of their colors yet.
- Wear a colorful coat or sweater to class.

I Am Thankful

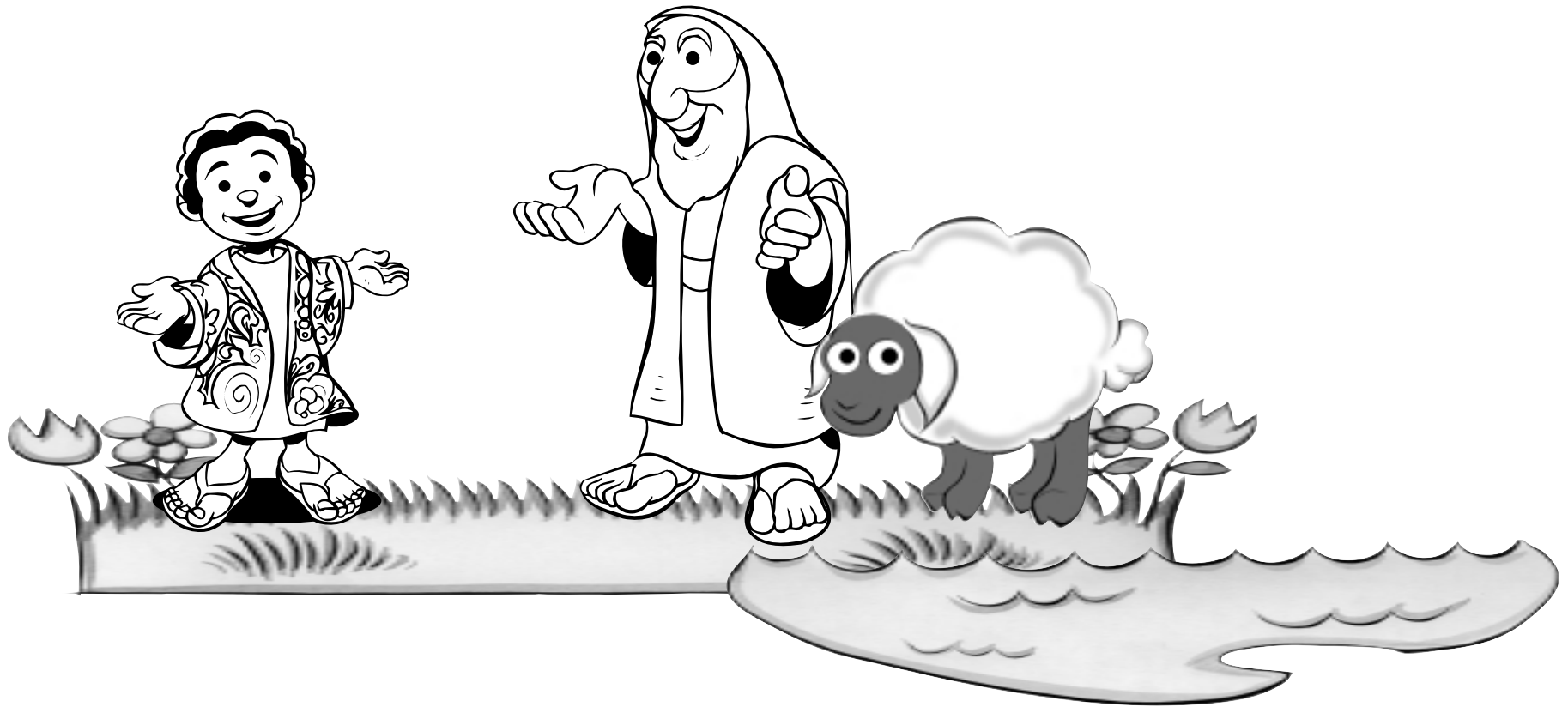

I Am Thankful

Lesli Gets a Present

The children will learn to be grateful for presents of clothing or gifts even if they are not toys.

Bible Truth

Give thanks to God.
(Psalm 136:26)

Materials

For the teacher:

- markers
- tape
- scissors
- felt board

Reproducible Pages:

- Page C, 1 copy for the teacher

Preparation

1. Cut out the figures from the copy of Reproducible Page C.
2. Familiarize yourself with the song and the story.

Instructions

Introduce the family figures and sing "My Own Loving Family" from the Unit 12 Song Sheet.

Put Lesli on the felt board.

Lesli woke up smiling. "Today is my birthday!" she said to herself. "Today is the best day of the year!"

Put Dad on the felt board.

Lesli ran down the stairs. Her daddy was just finishing reading his Bible. She ran to give him a hug. "Daddy, Daddy!" she said. "Do you know what today is?"

"Let me think now. Could it be somebody's birthday?" "Yes!" said Lesli. "It is my birthday!" I get to have cake; blow out my candles; and I get presents. And the presents are the best part!"

Just then the doorbell rang. It was Grandma and Grandpa!

Put Grandma and Grandpa and Mom on the felt board.

They had a big present wrapped in pretty paper with a shiny bow. "Is it for me?" she asked.

"Yes," said Grandpa, handing Lesli the present.

Lesli sat down on the floor to open her present. Lesli wondered what the present could be. Could it be a new baby doll? Could it be a new coloring book and crayons? Could it be a new stuffed animal? She ripped off the paper and opened the box. "Oh," said Lesli, looking sad, as she held up her present—"a sweater."

"How pretty!" said Mommy. "That was just what Lesli needed." "Lesli, what do you say?" But Lesli didn't say anything. The room got very quiet.

Take Grandma and Grandpa off of the felt board.

Grandma and Grandpa went into the other room and Daddy and Mommy sat down with Lesli. "Lesli," said Daddy, "You did not say thank you to Grandma and Grandpa. Grandma went shopping and picked out that sweater especially for you. Then she wrapped it up so pretty, so you would feel special."

Lesli started to cry. "But I wanted a new doll or a new coloring book or a new stuffed animal," she said. "I didn't want a sweater."

"Lesli," said Daddy, "you need to be grateful. When someone gives you a present, it is because they love you. You need to say 'thank you' and give them a big hug, even if the present is not a toy." Then Daddy opened his Bible and read to her about Joseph in the Bible, Joseph's daddy gave him a coat for a present. Joseph was very grateful and said thank you.

"Now," said Daddy, "what do you need to say to Grandma and Grandpa?"

"I need to hug them and tell them I am sorry and thank them for my new sweater," said Lesli. "That's right," said Daddy and Mommy, smiling.

Put Grandma and Grandpa on the felt board.

"Grandma, Grandpa," said Lesli, "I am sorry. Thank you for my new sweater."

Grandma and Grandpa hugged her. "We forgive you. Let's go and try on the new sweater and see if it fits." said Grandma.

"OK," said Lesli. Lesli tried it on and went to look in the mirror. It looked pretty! She ran back to Grandma. "Thank you, Grandma," she said, hugging her. "I really like it! And you picked my favorite color!"

NOTE: Save the felt board figures for the Unit 12 Lesson 4, Life Application.

I Am Thankful

Bible Truth Activity

God wants us to be thankful for him and for the people he gives us in our families. Who remembers our Bible Truth? "Give thanks to God." Repeat the Bible Truth a few times with the children.

Conclusion

Joseph was grateful when his daddy gave him a coat. We need to be grateful when people give us things too. Did Lesli learn to be grateful? Yes she did.

When we are thankful, it makes God happy and it shows we love him.

Teacher Tips

If you have saved the family figures from previous lessons then you will only need to make grandpa and the present.



C
r
a
f
t

I Am Thankful

Coat of Many Colors

The children will make a coat of many colors to remind them of Joseph's coat.

Materials

For each child:

- 1 brown paper grocery bag
- 1 glue stick
- crayons

For the teacher:

- colored construction paper
- scissors

Preparation

1. Cut the construction paper into 5" squares. Cut ten squares for each child.
2. Prepare a "coat" for each child as shown in Figure A:
 - A. Turn the bag upside down and cut a hole for the head and neck.
 - B. Cut an opening down the front of the bag.
 - C. On each side of the bag, cut two round holes for the arms.
3. Make a model of the craft following the instructions.

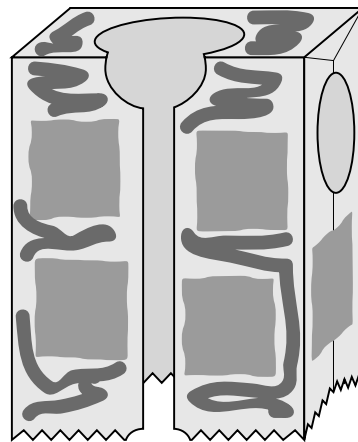

Instructions

1. Show the children the model of the coat. *Our Bible story today teaches us that Joseph's daddy gave him a present. What did Joseph's daddy give him? He gave him a coat of many colors. Today you get to make your own coat of many colors just like Joseph's coat!*
2. Give each child a coat.
3. Give the children each ten colored squares, and then have them glue the squares to the bag. See Figure B.
4. Give the children crayons to color their paper bags.
5. Help the children to put on their coats.

Conclusion

Give the children compliments on their coats. *You have all made such beautiful coats. Joseph had a beautiful coat of many colors too. Joseph loved the coat his father gave him. Who gives us coats, clothing, food, families and everything that we need? That's right, God does.*

Let the children say a short prayer thanking God for their beautiful coats and for the many things that he gives us.

Teacher Tips

- Crepe paper can be used instead of construction paper.
- Consider using additional materials to decorate the coats, such as stickers, yarn, sequins, etc.
- Use pinking shears to cut more decorative squares.

craft

I Am Thankful

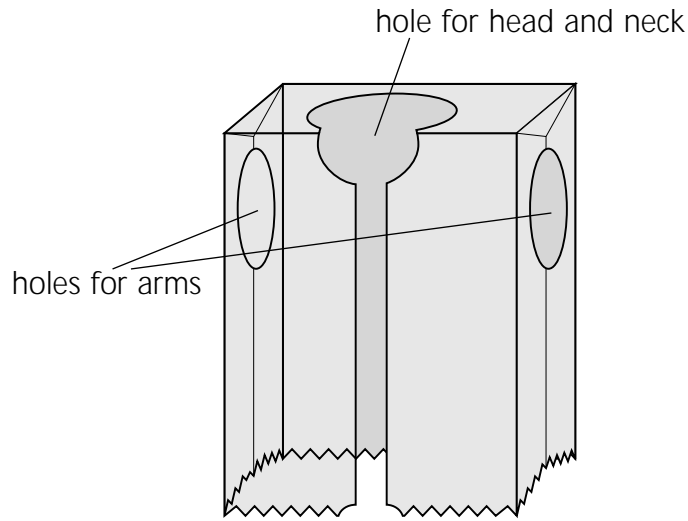

Figure A

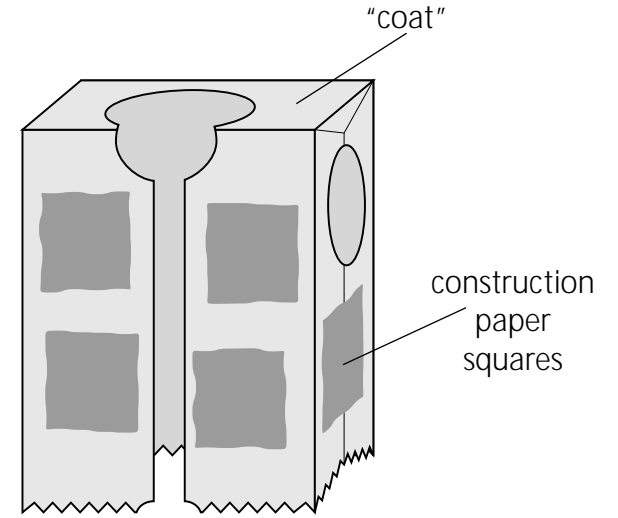
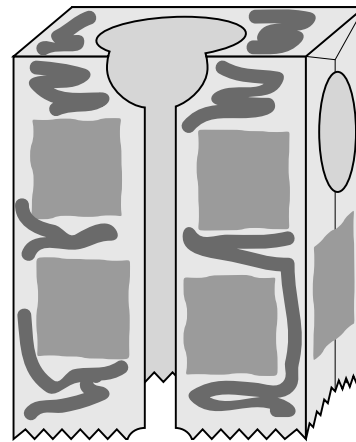

Figure B



Finished Craft





Lesson Objectives

- When asked who had the coat of many colors, the children will answer "Joseph."
- The children will thank their parents for taking care of them.
- The children will thank God for taking care of them.

Bible Story Text

Genesis 37:2a, 3b

Bible Truth

Give thanks to God.
(Psalm 136:26)

Preclass Centers

As the children arrive, guide them to a pre-class center. Have no more than six children at each center.

Materials

Use the materials previously selected for this unit's preclass centers.

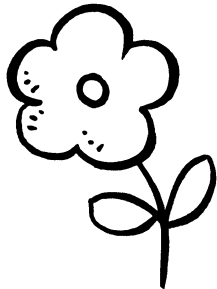

Preparation

1. Be sure to check the condition of the materials selected for this unit's preclass centers prior to set up. Replace any broken toys, or puzzles with missing pieces as necessary.
2. Set up the centers before the children come into the classroom.
3. Assign a teacher to each center and have the teachers stay in those centers until the singing begins.

Instructions

Guide the play in each center reinforcing the unit theme.

I Am Thankful

Thankfulness

Lesson 3

Lesson Plan

Greeting and Registration

Preclass Activity: Preclass Centers

Welcome and Singing

Centers:

Life Application: I Take Care of My Clothes

Bible Story: Joseph's Coat

Craft: Coat Frame

NOTE: Be sure to allow sufficient time for a snack.

Teacher Tips

- **IMPORTANT:** Do not allow any small toys in the classroom. First check all toys for size. You can obtain a "safety cylinder" from a pediatrician. Any object that can fit into the cylinder is too small and could cause a child to choke.
- Be involved in the group play and offer guidance as needed.
- Wear comfortable clothes suitable for sitting on the floor.
- Smile! Be childlike in heart and alert in mind.



I Take Care of My Clothes

The children will role play different activities that teach them how to take care of their clothes.

Bible Truth

Give thanks to God.
(Psalm 136:26)

Materials

For the teacher:

- laundry basket
- assorted clean clothes that can be divided into two distinct groups, boy's clothes and girl's clothes
- 5 pairs of socks, each pair distinct from the others
- Bible

Preparation

1. Familiarize yourself with the song and activity.
2. Spread the clothes on the floor before class.

Instructions

Today we are going to learn to take care of our clothes and to be thankful for them. Are we supposed to throw our clothes on the floor? No! We are supposed to pick them up and put them in the laundry basket when they are dirty.

Point to the clothes on the floor. *Who will help me pick up the clothes?* Have the children pick up the clothes and put them into the laundry basket. As they pick up the clothes sing verse one of "Thank You God for Clothes" from the Unit 12 Song Sheet.

Now let's pretend the clothes are washing in the washing machine. Make washing machine noises. *Now let's pretend the clothes are drying in the dryer.* Make drying motions with your hands.

Now the clothes are finished washing and drying. We need to separate and fold the clothes. First, let's separate the boys' clothes from the girls' clothes and make two piles. Let each child take an item of clothing from the basket and put the item into the appropriate pile. Continue until all the clothes are separated into two piles.

I Am Thankful

Sing verse two of "Thank You God for Clothes."

Now let's fold the clothes. Let each child fold an item and stack it in the basket. Assist them as needed. Sing verse three of "Thank You God for Clothes" while they are folding the clothes.

We have one more job to do. We need to match the socks! Put the socks on the floor and let each child have a turn finding a matching pair. Assist younger ones as needed. As the children work sing verse four of "Thank You God for Clothes."

Bible Truth Activity

God gives us beautiful clothes to wear. Open the Bible. *The Bible says, "Give thanks to God." Let's all say that together. Give thanks to God.*

Conclusion

Let's say a prayer to give thanks to God. Dear God, thank you for giving us clothes to wear. Help us to be thankful and to take care of our clothes. In Jesus' name we pray. Amen.

When we are thankful it makes God happy and helps people to see that God loves them.

Teacher Tips

- Make the two piles of clothes as distinct as possible for sorting.
- Make each pair of socks as distinct as possible for sorting (size, color, etc.).
- Children will not be able to fold and stack clothes neatly. Some will require assistance. Others will have a "do it myself" attitude. Allow them to fold the clothes and place them into the basket as neatly as they are able.

Joseph's Coat

The children will hear the story of Joseph's coat.

Bible Story Text

Genesis 37:2a, 3b

Materials

For the teacher:

- Bible
- felt board with a black background
- scissors
- markers
- tape
- clear contact paper or laminate
- construction paper, a different color for each child in the center

Reproducible Pages:

- Page A, 1 copy for the teacher
- Page B, 1 copy for the teacher

Preparation

1. If you do not have a felt board, one can be easily made with a piece of foam board, purchased at a craft, office or art supply store. Cut the board to approximately 11" x 17". Cover the board with a piece of black felt, overlapping the material with two-sided tape on the back.
2. Cut out, color and laminate the figures from the copies of Reproducible Pages A and B.
3. Roll a piece of tape to stick to the back of each figure.
4. Cut each piece of construction paper in half.
5. Familiarize yourself with the Bible Story. Practice telling the story using the flannel board figures.

A Present

Open the Bible to Genesis. *The Bible says there was once a daddy named Jacob. Put the Jacob figure on the felt board. He had a little boy named Joseph. Put the Joseph figure on the felt board. Joseph loved and obeyed his daddy. "Joseph, please go out and take care of the sheep," his daddy said. "OK, Daddy," said Joseph.*

Remove Jacob. Add the sheep, pond and grass to the felt board. *Joseph took the sheep to eat some grass. Move the sheep over to the grass. Then he took the sheep to a pond to get a drink. Move the*

I Am Thankful

Thankfulness

Lesson 3

sheep over to the pond. *Joseph knew it was time to go home. "Come on, sheep," he said. The sheep followed him home. Remove the grass and water. Make the sheep follow Joseph. Remove the sheep.*

Add Jacob to the felt board. *When Joseph got home, his daddy said, "Thank you, Joseph. You did a great job with the sheep. I have a present for you." Joseph was so excited! His daddy wanted to give him a present! Ask the children, Who likes to get presents? What do you think Joseph's daddy was going to give him? Let the children respond. Tell them their ideas would make great gifts. It was a beautiful new coat! (Genesis 37:3b) Add the coat onto the Joseph figure.*

Joseph's coat had many bright colors on it. He loved the bright colors! Hold the felt board close to the children and ask each child to point to a color. As the child points to a color, say: Do you know what color that is? That color is Red! Continue until each child has had a turn. Joseph loved his new coat. What do you think he said to his daddy? He said, "Thank you, Daddy! Thank you for my new coat."

Hold the felt board with Jacob, Joseph, and Joseph's new coat on it and sing "Joseph's Coat" from the Unit 12 Song Sheet.

NOTE: Save the felt board figures for the Unit 12 Lesson 4, Bible story.

Conclusion

Give each child a half of a piece of construction paper and put the matching halves on the floor in front of the children.

Let's pretend you want to make a coat the color that you are holding in your hand. Lydia, can you find the same color on the floor? Very good! Do you know what color that is? That color is yellow! Can everyone say "yellow"? Lydia can make a yellow coat. Repeat this with each of the children.

Show the felt board with the figures on it and sing Joseph's Coat one more time. Ask the children, *What do you say when someone gives you something? Right! You say, "Thank you!"*

Who had the coat of many colors? Yes, Joseph.

Teacher Tips

- Encourage the children as they try to name the colors. Many of them won't know all of their colors yet.
- Wear a colorful coat or sweater to class.

B
i
b
e
s
t
o
r
y

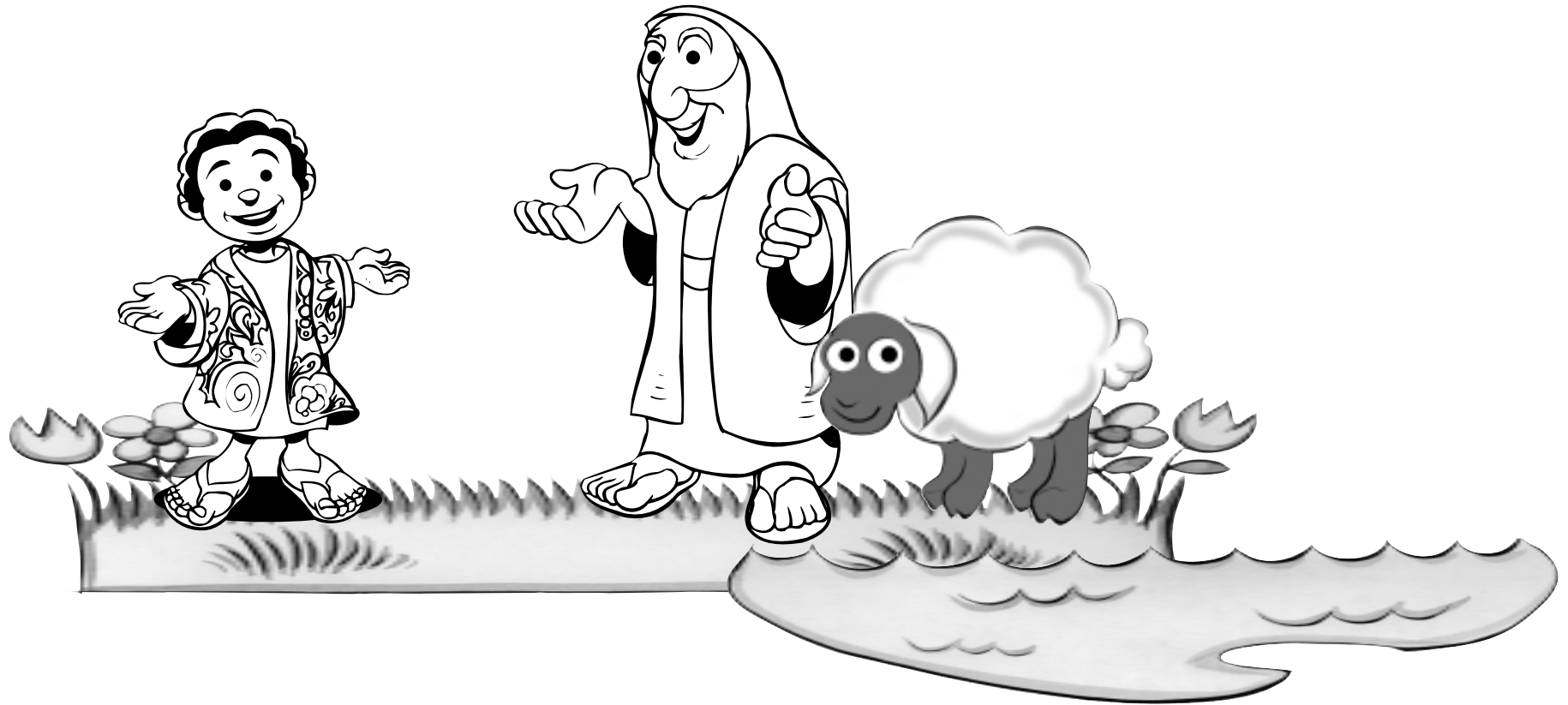

Coat Frame

The children will make special paintings of colorful coats.

Materials

For each child:

- 1 piece of white paper
- 1 piece of black construction paper
- T-shirt or smock

For the teacher:

- scissors
- black construction paper for “coats”
- pencil
- white crayon or gold/silver marker
- newspapers
- 3 colors of tempera paint, primary colors
- 3 paint brushes, 3”
- 3 shallow bowls
- plastic wrap
- wet paper towels
- clear tape

Reproducible Pages:

- Page D, 1 copy for each child

Preparation

1. Cut out the coat stencil and the scripture text box from the copies of Reproducible Page D.
2. Make a cutout of a coat on black construction paper for each child as follows:
 - A. Fold the black construction paper in half lengthwise.
 - B. Align the straight edge of the coat stencil with the fold of the paper and then trace the stencil with a pencil.
 - C. Cut out the “coat” from the paper as shown in Figure A.
IMPORTANT: Be sure to cut carefully along the line you traced.
 - D. Discard the coat and unfold the paper. See Figure B.
3. Glue the scripture text box on the top of each paper. See Figure C.
4. Make a model of the craft following the instructions.

Instructions

1. Prior to class set up a “paint station” as follows:
 - A. Place newspapers on your work surface to protect it against spills.

I Am Thankful

Thankfulness

Lesson 3

2. Show the model of the craft to the children. Hold the craft so the black paper is not showing and say: *What do you see? Yes, I see many pretty colors: yellow, red and blue.* Turn the black page over so that the children can see the coat. *Now what do you see? Yes, a coat! It looks like Joseph's coat of many colors.* Turn the page over and then back again a few times, so they can see the coat disappear and then appear. *Today you can make a painting and a coat too!*
3. Give each child a piece of white paper. Print each child's name on the paper before the child begins.
4. Help the children make paintings as follows:
 - A. Have the children, one at a time, paint one stripe of each color across their papers. See Figure D.
 - B. Place a large piece of plastic wrap on top of each child's painting.
 - C. Have each child gently tap and push the plastic around the paper to blend the colors of the painting.
 - D. Help each child to pull off the plastic wrap, and then discard it.
 - E. Help each child to clean up using the wet paper towels.
 - F. Place the paintings aside to dry.
5. Give the children each a piece of black construction paper. Help them tape the back of their paintings to the back of their black construction paper. See Figure E. NOTE: Have them tape the top edge only.
6. Using a white crayon, write the children's names on the front of their finished crafts.

Conclusion

Talk about how beautiful the colors are on the painting. Say, *I'm so grateful for the colors God gave us.*

Turn down the black page showing them the coat of many colors. *Joseph was thankful to God, too, for the beautiful coat his father gave him.*

Teacher Tips

- Ask the other teachers for help during this activity.
- Make sure the paint doesn't get too thick on the brushes or the paintings or they will take too long to dry.

C
r
a
f
t

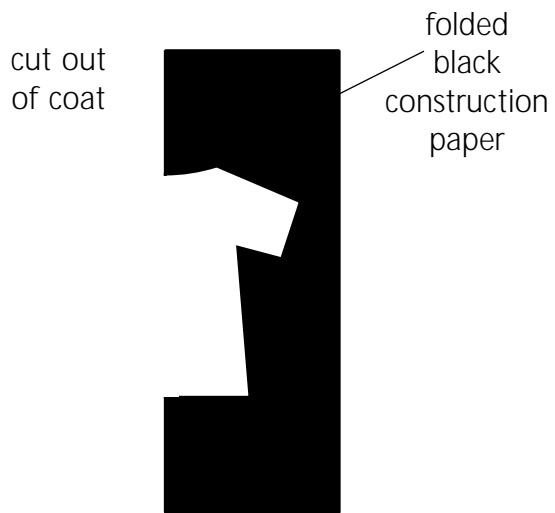

Figure A

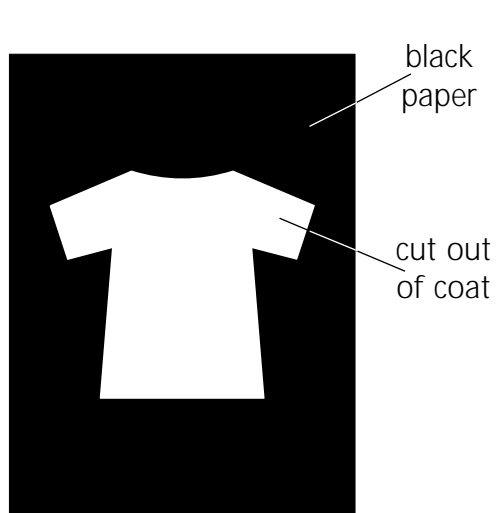

Figure B

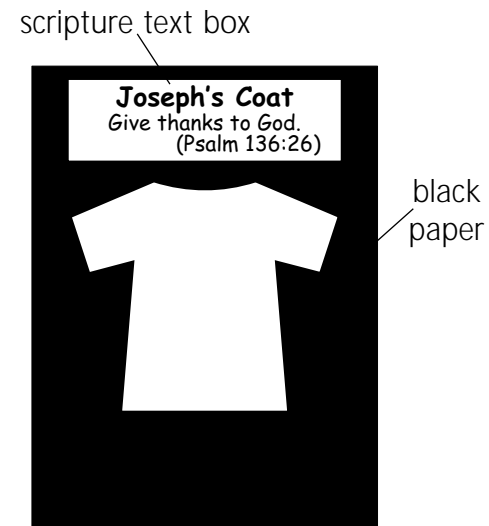

Figure C

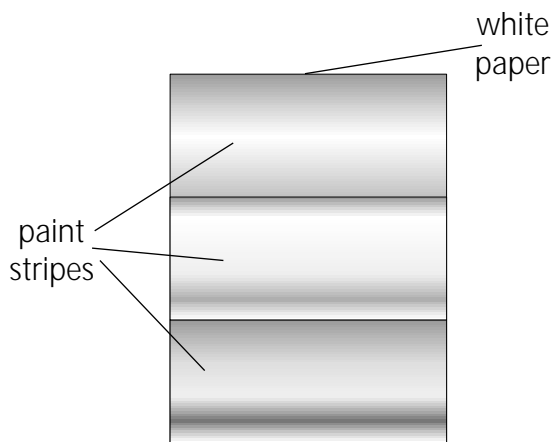

Figure D

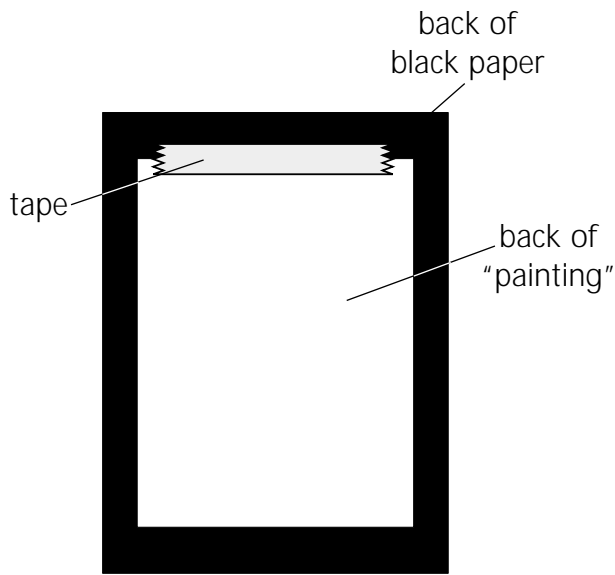
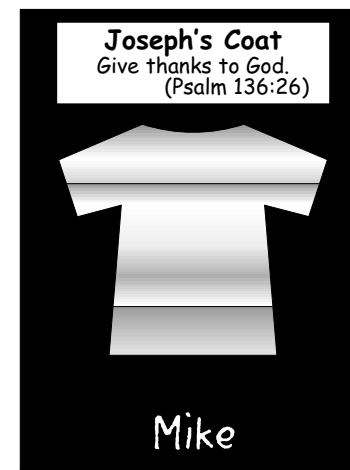

Figure E



Finished Craft





Joseph



Joseph's coat
of many colors



Jacob





B
R
E
P
A
R
E
T
H
Y
O
U
R
H
E
A
R
T

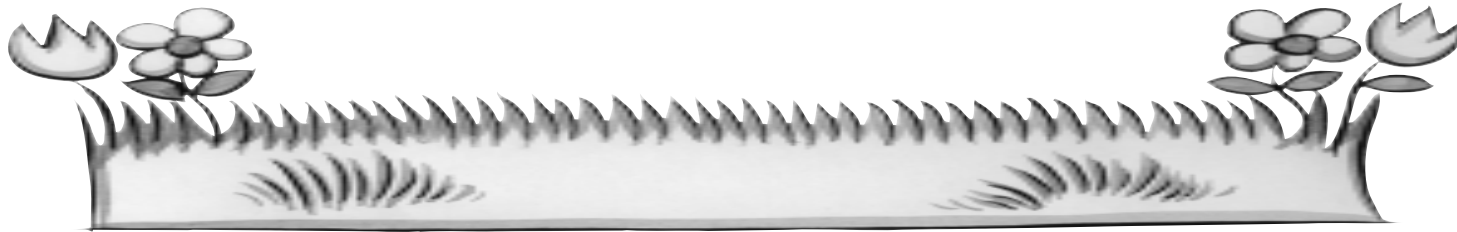

grass



pond



sheep





R
e
p
r
o
d
u
c
e
d
i
n
g

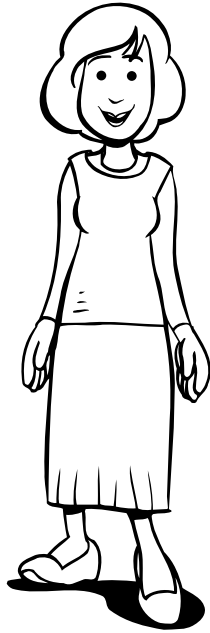

Mom

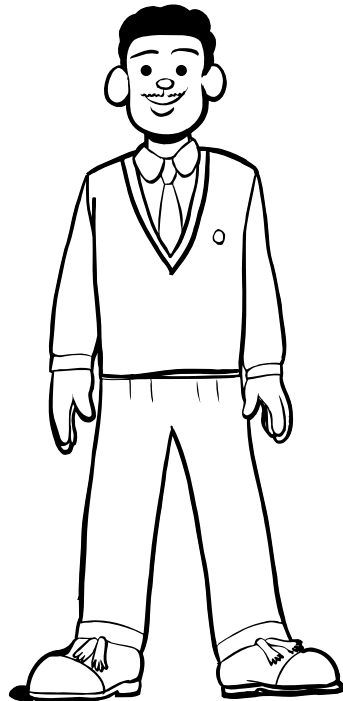

Dad



Grandma

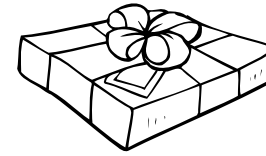

Present

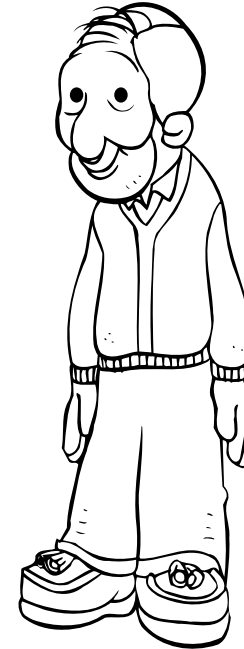

Grandpa



Lesli





R
e
p
r
o
d
u
c
i
o
n
e

Joseph's Coat
Give thanks to God.
(Psalm 136:26)

scripture text box

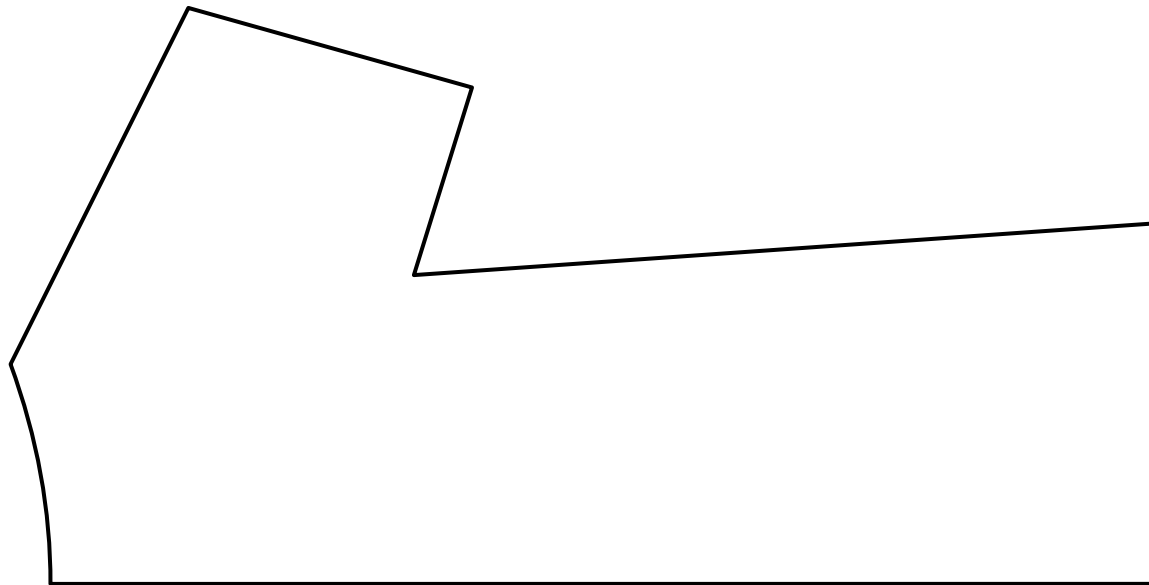

coat stencil

