

# Samuel

## Lesson Objectives

- The children will watch a puppet presentation of young Samuel.
- The children will tell that Samuel listened to God.
- The children will tell one way that they can listen to God.

## Lesson Text

1 Samuel 1-3

## Scripture Memory Verse

The LORD came and stood there, calling as at the other times, "Samuel! Samuel!"

Then Samuel said, "Speak, for your servant is listening."

*1 Samuel 3:10*

## Lesson Plan

Greeting and Registration

Preclass Activity: Search and Scramble

Welcome and Singing

Centers:

Bible Story: Samuel! Samuel!

Craft: When God Calls

Scripture Memory: Listen Up!

NOTE: Allow time for a snack.

## God's Young Heroes Lesson 1

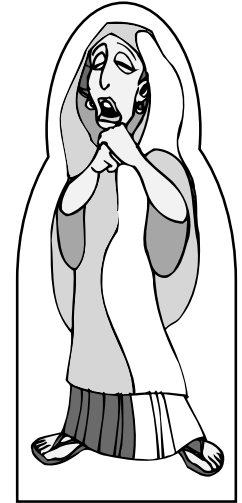

# Samuel

## Search and Scramble

The children will preview key words and ideas from today's lesson about young Samuel.

### Materials

For each child:

- pencil
- crayons or markers

Reproducible Pages:

- Page A, 1 copy for each child

### Preparation

Complete the activity on your copy of Reproducible Page A.

### Instructions

1. Greet the children as they arrive. Tell them that they will be learning about some children who were heroes in the Bible. Explain that today's lesson is about Samuel.
2. Distribute the copies of Reproducible Page A, pencils and crayons. Tell the children that there are words from today's Bible Story hidden in the word search. Then the same words are mixed-up and with letters missing. Encourage them to use the words at the bottom of the page to help them.
3. Help the children find a partner for this activity. Be careful to pair young or struggling readers with confident ones.
4. Circulate among the children to offer help and encouragement. Have the children check their answers with your answer key.

### Teacher Tips

- Be familiar with this week's Bible Story to talk with the children about the significance of the words in this activity.

### Search and Scramble

#### Write it right!

Write each word in the space:

HANNAH HANNAH  
CRY CRY  
PRAY PRAY  
BABY BABY  
SAMUEL SAMUEL  
HAPPY HAPPY

#### What's Missing?

Fill in the missing letters:

HA N N A H  
S A M U E L  
P R A Y  
C R Y  
B A B Y  
H A P P Y

#### Word Search

Circle the words from today's story:

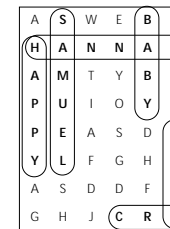

#### A Big Mix-Up

Can you put the letters in the correct order?

Example: NAHHAN HANNAH  
RYC CRY HYPPA HAPPY  
BYBA BABY RAYP PRAY  
AMUELS SAMUEL

Answer Box  
HANNAH      CRY      HAPPY  
BABY      PRAY      SAMUEL

#### Picture This!

On the back of this page, color a picture of a woman praying to God.

B

# Samuel

S

## Samuel! Samuel!

The children will watch a puppet presentation of today's Bible Story about young Samuel.

I

### Materials

For the teacher:

- 3 large craft sticks
- scissors
- tape
- crayons or markers
- 1 bed sheet or blanket
- 1 piece of construction paper, 9" x 12"

B

Reproducible Pages:

- Page B, 1 copy for the teacher (on heavy paper)

O

### Preparation

1. Cut out the puppet figures from your copy of Reproducible Page B.
2. Color and decorate the puppet figures. Tape each puppet to a craft stick.
3. Write neatly in large letters on the construction paper: SHILOH.
4. Practice telling the story using the props and puppets.
5. Before the Bible Story, drape the sheet over a table or chairs for a puppet stage. Place the "Shiloh" sign under the puppet stage.

L

### Introducing the Bible Story

Open your Bible to 1 Samuel chapter 1. *Today's Bible Story comes from the Old Testament book of 1 Samuel. You are going to learn about a young boy named Samuel who was a hero for God's people. Samuel came from a family that loved God and God had a great plan for Samuel's life.*

Show the children the puppets you prepared and introduce the characters:

- **YOUNG SAMUEL:** *His mother's name was Hannah and his father's name was Elkanah. As a young boy, Samuel grew up in the house of the Lord where he learned to serve God. God spoke to Samuel and Samuel listened and obeyed God.*

R

E

Y

- **HANNAH:** *She was Samuel's mother. Before Samuel was born, she was very sad because she had no children. She cried and prayed to God. She made a vow—or a promise—to God, saying that if she had a son, she would make sure that he served God for his entire life. She was a woman with amazing faith! Hannah's husband was called Elkanah. He loved God very much and he led his family to worship God. He also loved Hannah very much. He knew she was sad that she had no children.*
- **ELI:** *He was the priest—or leader of God's people—in Israel. He saw that Hannah was crying. He did not realize that she was praying. He thought she was drunk! But when she told him why she was praying to God, he blessed her.*

### Presenting the Bible Story: Shiloh Theater

Seat the children around the stage area. Tell them to listen carefully to the story of Samuel as you present the following puppet performance. Tell them that they will help you by making some important sounds for this story.

#### Scene 1: Shiloh

**NARRATOR:** *Every year Hannah and her husband Elkanah would travel from their home in Ramah to the Lord's temple in Shiloh. Ask the children to make the sound of feet walking. They went to worship God and make sacrifices to him. This time, Hannah was in the temple praying to God for a child. She was very sad because she had no children. Hannah cried and prayed to God. Eli the priest saw her praying and he thought she was drunk.*

**HANNAH:** *Oh, Lord Almighty, please remember me. I promise that if you will give me a son, I will give him to you all the days of his life.*

**ELI:** *Hannah is moving her mouth but not saying anything. Hannah, when will you stop getting drunk? Get rid of your wine.*

**HANNAH:** *I'm not drunk. I am very sad. I haven't been drinking but crying out to God in my prayer for a son. Have the children make the sound of a person crying. Please don't think that I am a wicked woman. It is only my great sadness that I don't have my own child.*



# Samuel

Eli: *Go home in peace. May the God of Israel give you a child.*

NARRATOR: *God answered Hannah's prayers and gave her a son.*

*They named him Samuel, which means, "Because I asked the Lord for him." When Samuel was a child, about 3 years old, she brought him to the Lord's temple in Shiloh to be Eli's helper and to grow up serving God. After Samuel had been with Eli for several years, God spoke to Samuel in the middle of the night.*

## Scene 2: Shiloh

NARRATOR: *Young Samuel was asleep in his bed. Eli was asleep in his bed. Have the children make the sound of a person sleeping. Samuel was awakened by a voice calling his name. Samuel got up and went to Eli's bed, and woke him. Samuel thought that Eli had called him. Have the children make the sound of feet walking.*

SAMUEL: *Here I am, you called me.*

Eli: *I didn't call you. Go back and lie down. Have the children make the sound of feet walking.*

NARRATOR: *Samuel went back and lay down. He heard the voice again saying, "Samuel, Samuel." Again Samuel got up and went to Eli. Have the children make the sound of feet walking.*

SAMUEL: *Here I am, you called me.*

Eli: *Samuel, I didn't call you. Now go back and lie down. Have the children make the sound of feet walking.*

NARRATOR: *Samuel returned to his bed. Again he heard the voice saying, "Samuel, Samuel." Once again, Samuel got up and went to Eli. Have the children make the sound of feet walking.*

SAMUEL: *Here I am, you called me.*

Eli: *Samuel, I know it was God who was calling you. Go back and lie down. If he calls again to you, say, "Speak, for your servant is listening."*

NARRATOR: *Samuel returned to his bed and again he heard the Lord calling him, "Samuel, Samuel."*

SAMUEL: *Speak, for your servant is listening.*

NARRATOR: *As Samuel grew older, God continued to speak to him and Samuel always listened. When he grew up, Samuel became a great judge, priest, and prophet. God was able to speak to his people through Samuel because Samuel obeyed God.*

## Alternate Idea: Mini-Shiloh Theatre

Take a box and turn it over so that the bottom is facing up. Cut long slits along the top. Cover the sides of the box with wrapping or construction paper. Label the side facing the children, "Shiloh." Place the puppet figures in the slits and move them back and forth from under the box as you tell the story.

## Share and Tell

Have the children sit in a circle. *God had a plan for Samuel before he was born. When his mother Hannah wanted a son, she cried and prayed to God. God answered Hannah's prayers and blessed her with a son. She gave him to God to help serve Eli in the temple. When God called Samuel, Samuel listened and obeyed. We can listen to God when someone reads the Bible to us, or when we go to the worship service of the church or to Bible Class. Ask the children how it makes them feel to know that God has a plan for their lives. Encourage them to tell the story of Samuel to their parents this week. Close with a prayer that the children will listen to God this week.*

## Teacher Tips

- Think of additional props for your puppet show such as small pillows or tissue boxes for beds, decorative items for the temple, etc.

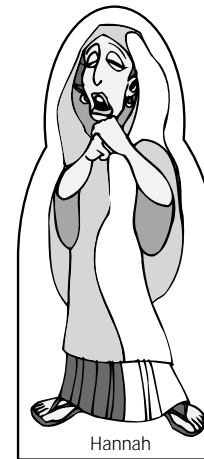

C



R



A



F



T



# Samuel

## When God Calls

The children will make a craft that will remind them that Samuel listened when God called him.

### Materials

For each child:

- 1 piece of black poster board, 2½" x 6"
- 1 pipe cleaner, 6"
- invisible or masking tape
- glue stick

For the teacher:

- scissors

Reproducible Pages:

- Page C, 1 copy for each child

### Preparation

1. Cut out the phone figures from the copies of Reproducible Page C.
2. On each piece of poster board, measure and draw a line two inches from the bottom, as shown in Figure A.
3. Make a sample craft to show the children.

### Instructions

1. Introduce today's activity: *In your Bible Story this week, you are learning about Samuel. Samuel's mother prayed to God for a son and promised that her son would serve God. When Samuel was a young child, he went to live in the house of the Lord. He learned to serve God there. When he was older, God spoke to Samuel at night and woke him up three times. Each time, Samuel listened to God's voice. Samuel grew up to become a great leader of God's people because he listened to God and obeyed. In your craft today, you will make a phone to remind you to listen to God when he calls.*
2. Distribute the poster board to the children. Show the children how to fold their poster board on the line that you prepared, as shown in Figure B.

3. Distribute the phone figures you prepared and glue sticks. Have the children place their poster board flat on their work surface and glue their phone figure onto the poster board, as shown in Figure C.
4. Distribute the pipe cleaners and tape. Help the children tape the pipe cleaner to the backs of their poster board so that it stands three inches above the top, as shown in Figure D.
5. Have the children write their names on their phones.

### Conclusion

Ask the children how they think they would feel if they heard God calling their name in the middle of the night the way Samuel did. Tell them that Samuel said, "Speak, for your servant is listening." Have the children hold their phones up to their ears and say together, "Speak, for your servant is listening." Tell the children that God does not call us on the telephone, but he does call us when we hear the words from the Bible. God calls us to listen and obey him. Each time you look at your phone, remember that God called Samuel to obey and he wants to call you too. Close with a prayer for the children to listen and obey God.

### Teacher Tips

- For a sturdier craft, give each child a piece of foam core (2½" x 6") instead of poster board and do not fold.
- If black poster board is not available, use cardboard or white poster board and have the children color it.

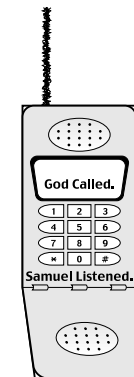

C  
•  
R  
•  
A  
•  
F  
•  
T  
•  
•  
•

# Samuel

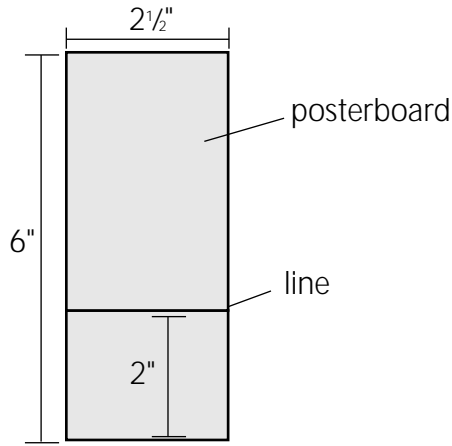

Figure A

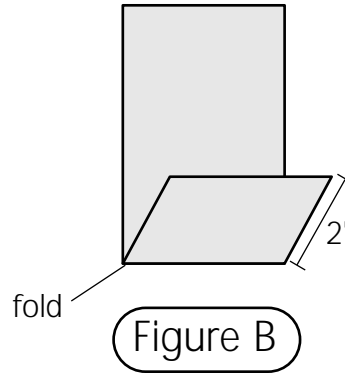

Figure B

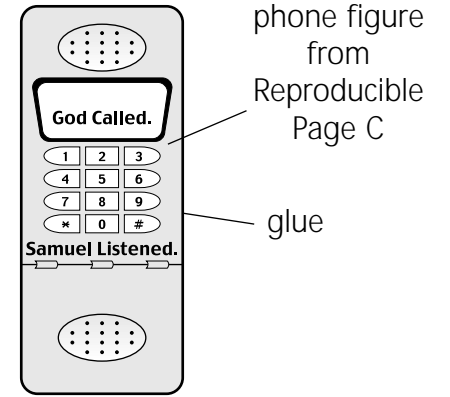

Figure C

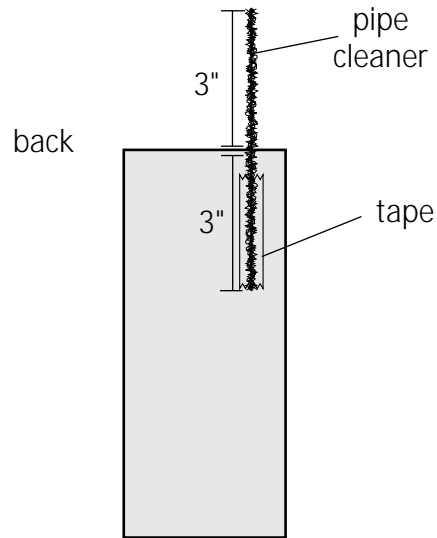
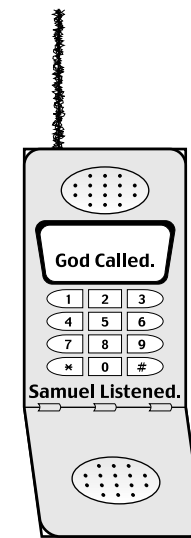

Figure D



Finished Craft



SCR  
IPT  
URE  
MEM  
ORY

# Samuel

## Listen Up!

The children will learn and memorize today's Scripture Memory Verse as they participate in this activity.

### Scripture Memory Verse

The LORD came and stood there, calling as at the other times, "Samuel! Samuel!"

Then Samuel said, "Speak, for your servant is listening."

1 Samuel 3:10

### Materials

For the teacher:

- 4 pieces of poster board, 9" x 12"
- marker

### Preparation

1. On a piece of poster board, write: "Lord" and on a second piece, write: "Samuel! Samuel!" On the third piece, draw a picture of a mouth, and on the fourth draw a picture of an ear.
2. Memorize today's Scripture Memory Verse.
3. Practice leading this activity using the posters.

### Instructions

1. Introduce today's activity: *In your Bible Story this week, you are learning about Samuel. Samuel's mother prayed to God for a son and promised that her son would serve God. When Samuel was a young child, he went to live in the house of the Lord. He learned to serve God there. When he was older, God spoke to Samuel at night and woke him up three times. Each time, Samuel listened to God's voice. Samuel grew up to become a great leader of God's people because he listened to God and obeyed. In your Scripture Memory Verse today, you will learn what God said to Samuel and what Samuel said to God.*
2. Show the children the Scripture Memory Verse on the back of this Lesson Card. Say it to the children three times as they follow along silently. Ask them to say the verse together with you three more times.
3. Ask the girls to say the verse with you, as the boys listen. Repeat this with the boys, as the girls listen.

4. Show the children the posters you prepared. Divide the children into two groups. Have them form two lines facing each other. Have one group stand up and say the first line of the verse, holding the first two posters. (The LORD came and stood there, calling as at the other times, "Samuel! Samuel!") Then have them sit down.
5. Next, have the second group stand and respond with the remainder of the verse, holding the other two posters. (Then Samuel said, "Speak, for your servant is listening.") Then have them sit down. Have all the children say the reference together. (1 Samuel 3:10)
6. Repeat Steps 4 and 5. Then have the children switch their lines and do it twice. With each turn, encourage the children to say the verse faster.
7. Ask for two volunteers to stand and say the entire verse and reference together by memory. Continue until all the children have had a chance.

### Conclusion

Tell the children to imagine how exciting it would be to have God call your name! Encourage them that God knows them each by name and wants to call them to listen and obey the way Samuel did. Encourage the children to tell their new verse with someone in their family today. Close with a prayer thanking God for God's plan for us to listen and obey.

### Teacher Tips

- You may also review the verse by leaving out some words and having the children call out the missing words.



# Samuel

SCR  
IPT  
URE  
MEM  
ORY

The LORD came and stood there,  
calling as at the other times,  
“Samuel! Samuel!”

Then Samuel said, “Speak, for  
your servant is listening.”

1 Samuel 3:10





## Lesson Objectives

- The children will watch a puppet presentation of young Samuel.
- The children will tell that Samuel listened to God.
- The children will tell one way they can listen to God.

## Lesson Text

1 Samuel 1-3

## Scripture Memory Verse

The LORD came and stood there, calling as at the other times, "Samuel! Samuel!"

Then Samuel said, "Speak, for your servant is listening."  
*1 Samuel 3:10*

## Lesson Plan

Greeting and Registration

Preclass Activity: Hannah's Hands

Welcome and Singing

Centers:

Life Application: Give Him Your Ears

Game: Capture the Flag

Bible Skills: What's in a Name?

NOTE: Allow time for a snack.



pre  
class

ACTIVITY

## Hannah's Hands

The children will make a craft that will review this week's lesson about young Samuel.

### Materials

*For each child:*

- crayons or markers
- glue sticks
- magazine picture of a baby

*For the teacher:*

- scissors

*Reproducible Pages:*

- Page D, 1 copy for each child

### Preparation

1. Cut out Hannah's Hands from the copies of Reproducible Page D.
2. Cut out magazine pictures of babies. Make sure you have enough so each child has one picture.
3. Make a sample to show the children.

### Instructions

1. Greet the children as they arrive. Remind them that they are learning about young Samuel. Tell the children that Samuel's mother cried out to God in prayer to have a baby, and God heard her prayer and gave her Samuel. Show the children the craft you prepared.

2. Distribute the Hannah's Hands that you prepared, crayons, glue sticks and magazine pictures. Have the children fold the hands on the dotted line. Tell the children to color the hands.
3. When they are ready, have them glue the picture of a baby inside the hands as a reminder that Hannah prayed to God for her baby. Make sure they write their names on their crafts.

### Teacher Tips

- For large classes, ask teaching assistants or parents to help with the cutting preparation of this activity.

## Give Him Your Ears

The children will review this week's lesson as they think of ways that they can listen to God.

### Materials

*For the teacher:*

- 6 index cards, 3" x 5"
- glue stick
- scissors

*Reproducible Pages:*

- Page E, 1 copy for the teacher

### Preparation

1. Cut out the Ear Cards from your copy of Reproducible Page E and glue them to the index cards.
2. Practice leading this activity.

### Reviewing the Bible Story: Samuel Listened to God

Open your Bible to 1 Samuel chapter 1. *In your Bible Story this week, you learned about Samuel. Samuel's mother prayed to God for a son and promised that her son would serve God. When Samuel was a young child, his mother Hannah took him to live in the house of the Lord. He learned to serve God there. When he was older, God spoke to Samuel one night and woke him up! Samuel listened to God's voice. Samuel grew up to become a great leader of God's people because he listened to God and obeyed.*

Ask the children if they remember the Scripture Memory Verse. Let the children say the verse from memory and offer help and encouragement. (The LORD came and stood there, calling as at the other times, "Samuel! Samuel!" Then Samuel said, "Speak, for your servant is listening." 1 Samuel 3:10)

### Life Application: Give God Your Ears

Explain that God spoke to Samuel and Samuel listened and obeyed. Today, God does not speak to us the way he spoke to Samuel. The Bible says that God speaks to us today in different ways. Ask the children how they think that God speaks to us today. (Take responses.)

Show the children the Ear Cards that you prepared and read each one to the children. Shuffle them and distribute them to the children. Have them look at their cards. Go around in a circle and have them say "God speaks to me through \_\_\_\_\_," completing the blank with the words on their cards.

Collect the cards, then shuffle and distribute them again. Go around the circle a second time, having the children say: "I will listen to \_\_\_\_\_," the same way as before. Collect the cards, then shuffle and distribute them again. Go around the circle a third time, having the children repeat this activity with their new cards.

For the final round, collect the cards, shuffle, and distribute them again. Go around the circle for the last time, repeating this activity with their last set of cards.

Collect the cards and hold them up one at a time. Tell the children that God uses each of these to help the children know what is right and to help them do it.

### Conclusion

Ask the children to think about the people they listen to every day: friends? family? teachers? coaches? TV? radio? Ask them how they think it would help them if they listened to God every day. Encourage the children to think every day about listening to God. Close with a prayer in which the children all ask God to help them be good listeners.

### Teacher Tips

- Some children may question how God can speak through their unbelieving parents or teachers. Encourage them that God can speak to them through anyone as long as they are listening!

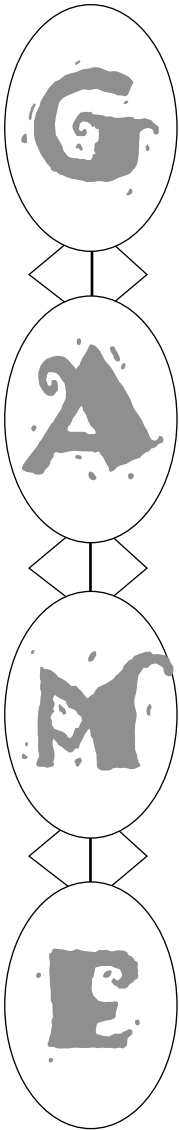

## Capture the Flag

The children will review important ideas from this week's lesson as they play this game.

### Materials

For each child:

- self-sticking name tag
- pencil

For the teacher:

- 1 fabric scrap, about 10" x 10"
- pencil and paper

### Preparation

Practice playing this game.

### Instructions

1. Introduce today's activity: *In your Bible Story this week, you learned about Samuel. Samuel's mother prayed to God for a son and promised that her son would serve God. When Samuel was a young child, he went to live in the house of the Lord. He learned to serve God there. When he was older, God spoke to Samuel at night and woke him up three times. Each time, Samuel listened to God's voice. Samuel grew up to become a great leader of God's people because he listened to God and obeyed. In our game today, you are going to hear some questions about this week's Bible Story and decide if the answer is "yes" or "no."*
2. Divide the children into two teams. Be careful to balance children who did not hear this week's Bible Story with those who did. One team will be the "YES" team and the other will be the "NO" team. Distribute the name tags and have the children write the names of their team on them.
3. Have the teams sit in two lines facing each other and about five feet apart. Place the fabric scrap on the floor an equal distance between the two teams. It is the flag in this game.

4. Tell the children that you will read questions about this week's Bible Story. If the answer is "Yes" then the YES team must try to be the first to capture the flag. If they succeed in capturing the flag first, they must be able to give the correct answer (yes) and they will receive two points. If a child on the NO team takes the flag first, they must give the correct answer (yes) and they receive one point.
5. Keep score for the children. The team with the most points at the end of the game wins.
6. If time permits, play a second round, and having the children switch teams.

### Flag Football Alternative

For outside play: Assign each team a color and each player his own flag. Line the teams about ten feet apart facing each other. After the question is asked, have the team with the correct answer try to capture flags from the other team. For example: if the answer to the question is "Yes" then the YES team has 30 seconds to try and steal flags from the NO team. Teams earn a point for each flag taken. Return the captured flag after each round. Play continues until all the questions have been asked.

### Conclusion

Have the children sit in a circle. Ask them what they liked best about this week's Bible Story on Samuel. Close with a prayer thanking God for Samuel and his family and their faith in God.

### Teacher Tips

- To save time, write Yes or No on the children's name tags ahead of time.

## Capture the Flag

Yes and No Questions

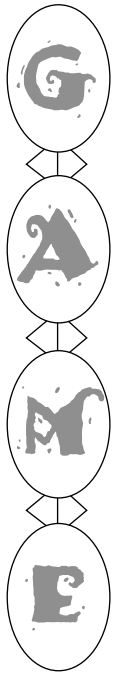

1. Hannah was sad because she had no children. (Yes)
2. Hannah's husband's name was Noah. (No)
3. Hannah and Elkanah went to the temple every year to worship God. (Yes)
4. Hannah cried and prayed to God to have a child. (Yes)
5. Hannah got drunk on wine. (No)
6. Hannah made a promise to God that her child would serve the Lord his whole life. (Yes)
7. A vow is a kind of animal. (No)
8. Eli the priest thought that Hannah was drunk. (Yes)
9. God gave Hannah a baby boy after she had prayed to God. (Yes)
10. Hannah named her child Elkanah. (No)
11. Hannah named her child Samuel. (Yes)
12. When Samuel was a young boy, Hannah took him to a baseball game. (No)
13. When Samuel was a young boy, Hannah took him to live with the priest in the house of the Lord. (Yes)
14. Samuel helped Eli the priest and learned to serve God. (Yes)
15. When Samuel was older, he ran away from home. (No)
16. When Samuel was older, he heard God calling his name. (Yes)
17. At first, Samuel did not realize that God was calling his name. (Yes)
18. Eli told Samuel that God was calling him. (Yes)
19. Samuel listened to God. (Yes)
20. Samuel obeyed God. (Yes)

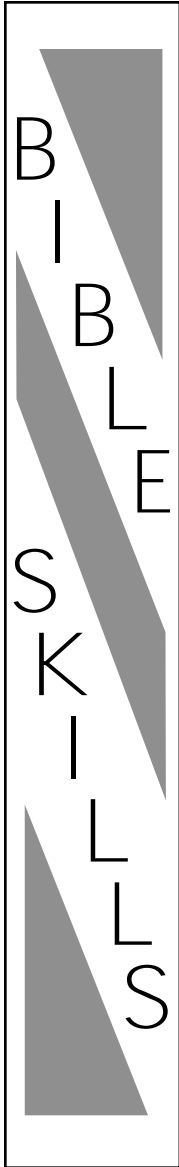

## What's in a Name?

The children will look up scriptures that define different names in the Bible.

### Materials

For each child:

- pencil

For the teacher:

- large writing surface

Reproducible Pages:

- Page F, 1 copy for each child

### Preparation

1. On the large writing surface, write: Genesis 25:24-26; Exodus 2:10; 1 Samuel 1:20.
2. Complete the activity on your copy of Reproducible Page F.

### Instructions

1. Introduce today's activity: *This week you are learning about Samuel. Samuel's mother was a woman of great faith. She prayed to God for a son and named him Samuel because it means, "I asked the Lord for him." Names can have very special meanings. In the Bible, there are several people whose names told a special story about them.*
2. Distribute the copies of Reproducible Page F and the pencils. Have the children find a partner to work with. Tell the children to look up the names on their pages and match them to their meanings in the other column.
3. Tell the children to turn their Bibles to Genesis 25:24-26. Tell them to find verse 25 and the words, "whole body was like a hairy garment" on their pages and draw a line from it to Esau. Then have them find verse 26 and the words "hand grasping Esau's heel" and draw a line from it to Jacob.

4. Tell the children to turn to the book of Exodus. Tell them to turn to chapter 2 and verse 10. Read the verse to the children. Tell them to find the words "I drew him out of the water" on their pages and draw a line from it to Moses.
5. Tell the children to turn to 1 Samuel 1:20. Tell them to find the words "I asked the Lord for him" on their pages and draw a line from it to Samuel.

### Conclusion

Ask the children if they know what their name means. Encourage the children that their names are very special just as they are very special. God called Samuel by his name. God knows each of the children's names and loves each one of them. Close with a prayer thanking God for his special love for each of us.

### Teacher Tips

- Bring in a book of names to help the children learn what their names mean.





# What's in a Name?

# Samuel

Name \_\_\_\_\_

Esau

I drew him out  
of the water.

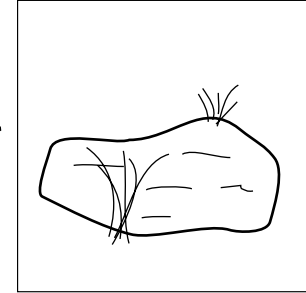

Jacob

hand grasping  
Esau's heel

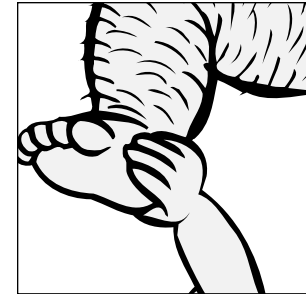

Moses

I asked the  
Lord



Samu

whole body  
was like a

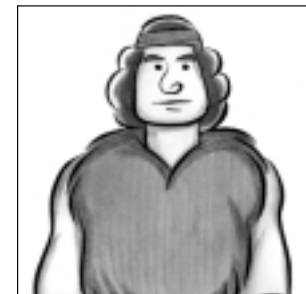

Core/Preclass  
1 copy for each child

## Search and Scramble

### Write it right!

Write each word in the space:

HANNAH HANNAH

CRY \_\_\_\_\_

PRAY \_\_\_\_\_

BABY \_\_\_\_\_

SAMUEL \_\_\_\_\_

HAPPY \_\_\_\_\_

### Word Search

Circle the words from today's story:

A	S	W	E	B	R
<u>H</u>	<u>A</u>	<u>N</u>	<u>N</u>	<u>A</u>	<u>H</u>
A	M	T	Y	B	U
P	U	I	O	Y	P
P	E	A	S	D	P
Y	L	F	G	H	R
A	S	D	D	F	A
G	H	J	C	R	Y

### What's Missing?

Fill in the missing letters:

HA \_\_\_ A H

S \_\_\_ M U \_\_\_ L

P R \_\_\_

C \_\_\_ Y

B \_\_\_ B \_\_\_

H A P \_\_\_

### A Big Mix-Up

Can you put the letters in the correct order?

Example: NAHHAN HANNAH

RYC \_\_\_\_\_ HYPPA \_\_\_\_\_

BYBA \_\_\_\_\_ RAYP \_\_\_\_\_

AMUELS \_\_\_\_\_

Answer Box		
HANNAH	CRY	HAPPY
BABY	PRAY	SAMUEL

### Picture This!

On the back of this page, color a picture of a woman praying to God.

R  
E  
P  
R  
O  
D  
U  
C  
I  
B  
L  
E

PAGE  
A



Core/Bible Story

1 copy for the teacher (on heavy paper)

R  
E  
P  
R  
O  
D  
U  
C  
I  
B  
L  
E  
P  
A  
G  
E  
B

PAGE

B

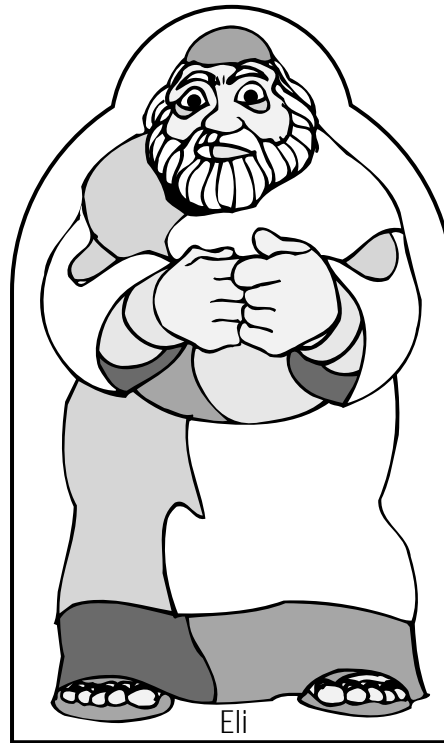
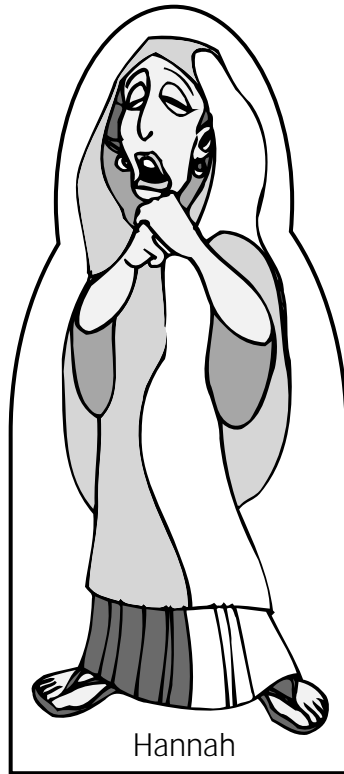



**Core/Craft**  
1 copy for each child

R  
E  
P  
R  
O  
D  
U  
C  
I  
B  
L  
E  
P  
A  
G  
E  
C

PAGE

C

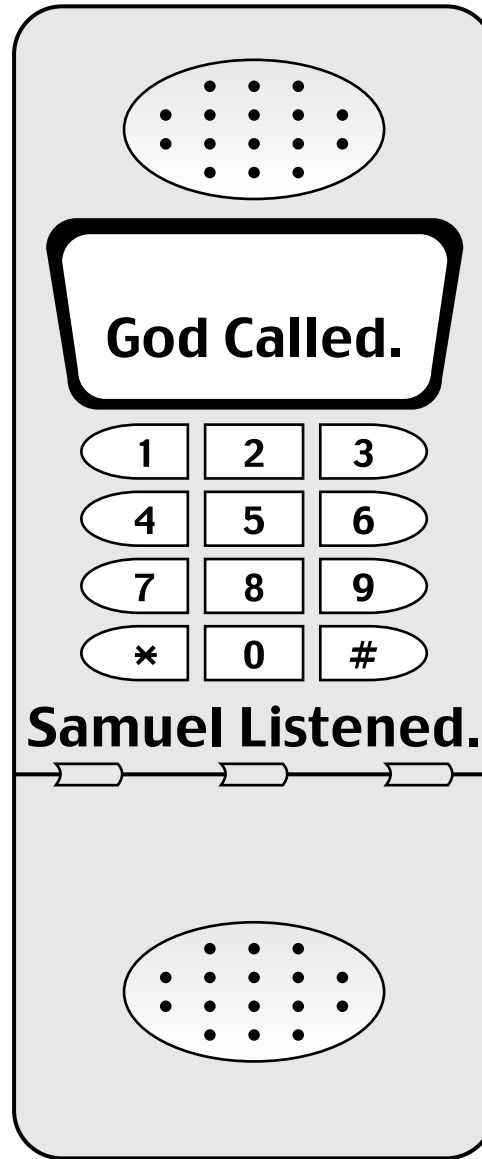

phone figure



This page intentionally left blank



Supplement/Preclass

1 copy for each child

R  
E  
P  
R  
O  
D  
U  
C  
I  
B  
L  
E

PAGE

D



Supplement/Life Application

1 copy for the teacher

R  
E  
P  
R  
O  
D  
U  
C  
I  
B  
L  
E  
P  
A  
G  
E  
E

The Words  
in  
the Bible



My  
Teachers



My  
Parents



The Words  
in  
the Bible



My Friends  
Who Love and  
Obey God



My  
Parents



Supplement/Bible Skills  
1 copy for each child

### What's in a Name?

Name \_\_\_\_\_

# Esau

I drew him out  
of the water.

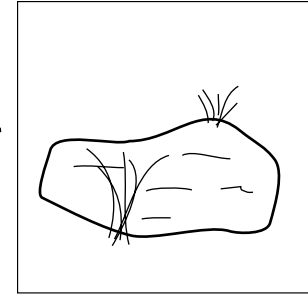

# Jacob

hand grasping  
Esau's heel

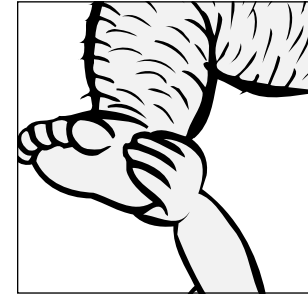

# Moses

I asked the  
Lord



# Samu

whole body  
was like a

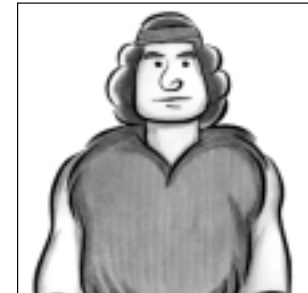

R  
E  
P  
R  
O  
D  
U  
C  
I  
B  
L  
E

PAGE  
F

