

I Love to Share

Lesson Objectives

- The children will identify what the boy shared with Jesus.
- The children will role play sharing.
- The children will sing about sharing.

Bible Story Text

John 6:1-13

Bible Truth

Share with others.
(Hebrews 13:16)

Lesson Plan

Greeting and Registration

Preclass Activity: Preclass Centers

Welcome and Singing

Centers:

Bible Story: A Boy Shares His Lunch

Life Application: Sharing or Selfish

Craft: Lunch Leftovers

NOTE: Be sure to allow sufficient time for a snack.



I Love to Share

Preclass Centers

As the children arrive, guide them to a preclass center. Have no more than six children at each center.

Materials

Use the materials previously selected for this unit's preclass centers.

Preparation

1. Be sure to check the condition of the materials selected for this unit's preclass centers prior to set up. Replace any broken toys, or puzzles with missing pieces as necessary.
2. Set up the centers before the children come into the classroom.
3. Assign a teacher to each center and have the teachers stay in those centers until the singing begins.

Instructions

Guide the play in each center reinforcing the unit theme.

Teacher Tips

- **IMPORTANT:** Do not allow any small toys in the classroom. First check all toys for size. You can obtain a "safety cylinder" from a pediatrician. Any object that can fit into the cylinder is too small and could cause a child to choke.
- Be involved in the group play and offer guidance as needed.
- Wear comfortable clothes suitable for sitting on the floor.
- Smile! Be childlike in heart and alert in mind.

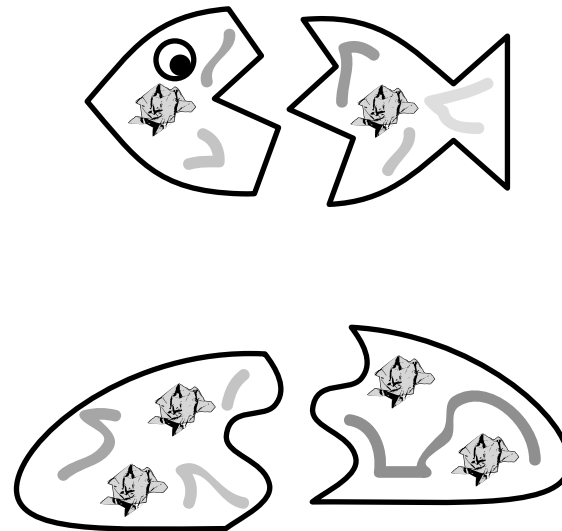

I Love to Share

A Boy Shares His Lunch

The children will learn the Bible story by sharing bread and fish.

Bible Story Text

John 6:1-13

Materials

For the teacher:

- Bible
- paper bread and fish from the Unit 10 Lesson 1, Bible Story
- 1 large basket
- 1 small basket
- 1 loaf of sliced bread
- fish-shaped crackers

Preparation

1. Place the paper bread and fish shapes into the small basket.
2. Prepare the food as follows:
 - A. Cut each slice of bread into quarters.
 - B. Place the bread and the fish crackers into the large basket.
3. Familiarize yourself with the story and the songs.

Instructions

Place the baskets behind you as you sit with the children. Open your Bible and begin to tell the story.

Point to your eyes and say, *Many people came to see Jesus. Cup your hands behind your ears and say, Many people came to hear Jesus teach. Jesus would teach for a long time. The people would start to get hungry. Rub your stomach and say, Jesus wanted to give them something to eat. Jesus asked his friends, "Do you have some food to share?" (John 6:5). Look at each child and show your empty hands while shrugging your shoulders as you ask each child, Do you have any food to share? After you have asked each child, shake your head and sigh, saying, Jesus' friends did not have any food, and we don't have any food either.*

Show the small basket. With an excited voice say, *One of Jesus' friends, Andrew, said "This little boy wants to share his food!" (John 6:8) Show the paper bread and fish. Say, The little boy had five loaves of bread and two fish. Let's count them: one fish, two fish! Do the same with the bread.*

Say to the children, *Jesus' friends said, "This is still not enough*

for everyone." Look sadly at the children and shake your head.

Fold your hands as if you are praying and say, *So Jesus prayed, and guess what happened? They began to share the food with all the people and soon there was enough for everyone!*

Bring out the large basket and say, *We have bread and fish crackers to share! I'm going to pretend to be the little boy and I want to share my bread with you.* Ask each child if he or she would like to share your bread.

Pass the basket to a child and ask, *Would you like to pretend to be the little boy and share the fish crackers with everyone?* Let each child take a turn.

Sing "We Like to Share Our Fish" from the Unit 10 Song Sheet.

Conclusion

It makes Jesus, God and our parents happy when we share. Let's pray to thank God for all the things he gives us that we can share with others. Say a short prayer with the children.

Teacher Tips

IMPORTANT: Be sure that none of the children have allergies to any of the snacks you may serve during this activity. Ask the parents at registration if their child has any food intolerance or food allergies.



I Love to Share



I Love to Share

Sharing or Selfish

The children will learn that Jesus wants us to share and that sharing makes everyone happy.

Bible Truth

"Share with others."
(Hebrews 13:16)

Materials

For the teacher:

- Bible
- a box of toys
- stick puppet from the Unit 10 Lesson 2, Life Application

Preparation

Familiarize yourself with the activity and the song.

Instructions

Open your Bible and remind the children of the story of the boy who shared his lunch with Jesus. Ask them, *Does anyone know what the little boy shared?* Hold up five fingers. *He shared five loaves of bread. Let's count. One...two...three...four...five!* Hold up two fingers. *He also shared how many fish? That's right! He shared two fish, one...two!* What did the little boy share? *Can everyone show me five fingers for five loaves of bread? Good! Can everyone show me two fingers for two fish? Great!*

Show the children the happy side of the stick puppet. *This is my friend. His name is Stephen. Can you say "hi" to Stephen? Stephen is a good boy, but sometimes he is selfish.* Turn to the unhappy side of the puppet, *Sometimes he does not like to share. This is Stephen's toy box. Show the children the box of toys. These are Stephen's toys. Would you like to ask Stephen if you can play with one of his toys?* Have a child ask the question. Have Stephen shake his head "no." Look sad and surprised, and then talk to Stephen. *Stephen, you are not being a very good friend.* Ask the children, *Do you think Stephen is being a very good friend? No, he is not. Why isn't he? That's right, because he is not sharing.*

Sing "Sharing Stephen" from the Unit 10 Song Sheet.

Talk to Stephen. *Stephen, do you want to be a Selfish Stephen? Make the unhappy side of the puppet shake his head "No!" Do you want to be a Sharing Stephen and make Jesus happy? Make the happy side of the puppet nod "Yes!" Let's all clap for Stephen. He is choosing to be a Sharing Stephen.* Have the puppet jump excitedly as the children clap for him. Have Stephen direct each child to take a toy from the toy box. As each child chooses a toy, remind them to say "thank you."

Ask the children, *When Stephen was being selfish, was he happy or sad? That's right. He was sad.* Show the sad side of the puppet. Ask, *When Stephen was sharing, was he happy or sad? That's right! He was happy.* Show the happy side of the puppet.

Bible Truth Activity

Open the Bible. *The Bible says, "Share with others." Let's all say that together. Share with others. Thomas, will you share with others?* As each child says "yes," have Stephen give them a hug.

Conclusion

Sing the song again.

When we share with others it helps them to know that God loves them and that they are special.

Say a short prayer to ask God to help us to be happy people who like to share.



I Love to Share



Craft

I Love to Share

Lunch Leftovers

The children will make "leftovers" to remind them of the feeding of the five thousand.

Materials

For each child:

- 1 small paper lunch bag
- crayons or markers

For the teacher:

- scissors
- tape
- brown tissue paper
- colored tissue paper (excluding brown)
- wiggle eyes or sequins
- black marker

Reproducible Pages:

- Page A, 1 copy for each child

Preparation

1. Prepare a "basket" for each child as follows:
 - A. Cut off the top half of each bag. See Figure A.
 - B. Cut a 8" x 2" strip from the leftover top half of each bag to make a handle.
 - C. Tape a handle securely onto each basket. See Figure B.
 - D. Print "_____ shares!" on the side of each bag.
2. Prepare the fish and loaves as follows:
 - A. Cut out the fish and loaves from the copies of Reproducible Page A.
 - B. Cut the fish and loaves in half along the cut line.
 - C. Place one complete fish and one complete loaf into a basket for each child.
3. Cut the brown tissue paper into 1" squares. Cut eight for each child.
4. Cut the colored tissue paper into 1" squares. Cut eight for each child.
5. Make a model of the craft following the instructions.

Instructions

1. Introduce the craft as follows: *Once Jesus helped a little boy share his lunch with many people. The boy had five fish and two loaves of bread in his basket. Can you count to five with me? One...two...three...four...five loaves of bread! Jesus fed over five thousand people with those five loaves of bread. When everyone had finished eating there were leftover pieces of bread and fish. Show the children the craft. Today we are going to make a basket of leftovers too!*
2. Give each child a basket with a fish and loaf inside of it.
3. Have the children color both the fronts and backs of their fish and loaves.
4. Give the children each two wiggle eyes. Help them glue these, one on each side of their fish, making "fish eyes."
5. Give each child eight squares of brown tissue paper. Have them glue these to both sides of their loaves.
6. Give each child four squares of colored tissue paper. Have them glue these to both sides of their fish.
7. Write the children's names on their baskets.

Conclusion

Let the children take turns putting the bread and fish pieces together. Talk about how happy Jesus was with the little boy who shared his lunch.

Teacher Tips

Instead of using brown paper strips for the basket handles try substituting ribbon, thick yarn, or pipe cleaners.

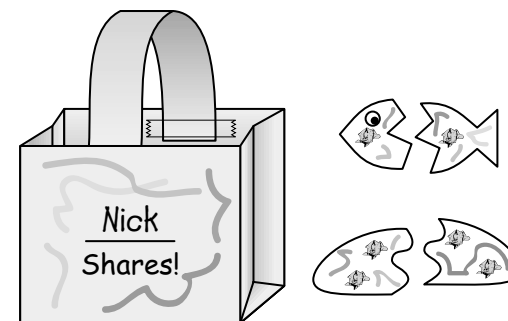

craft

I Love to Share

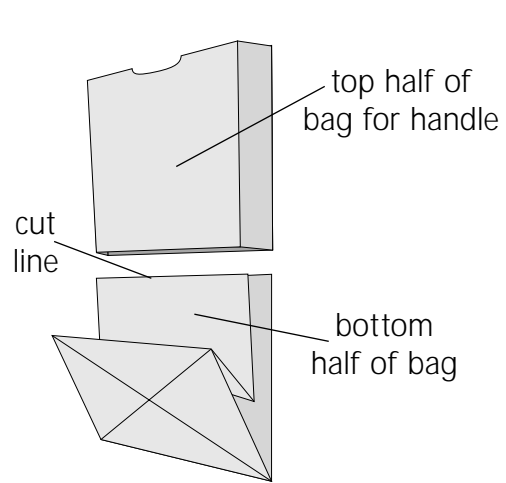

Figure A

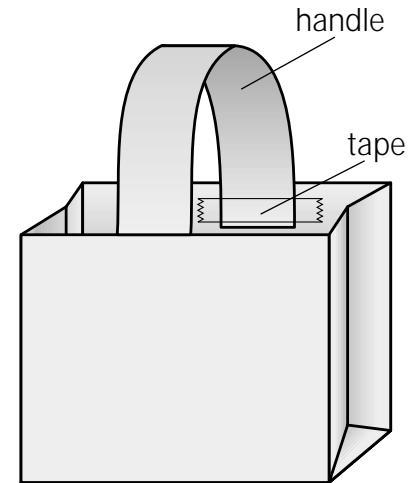
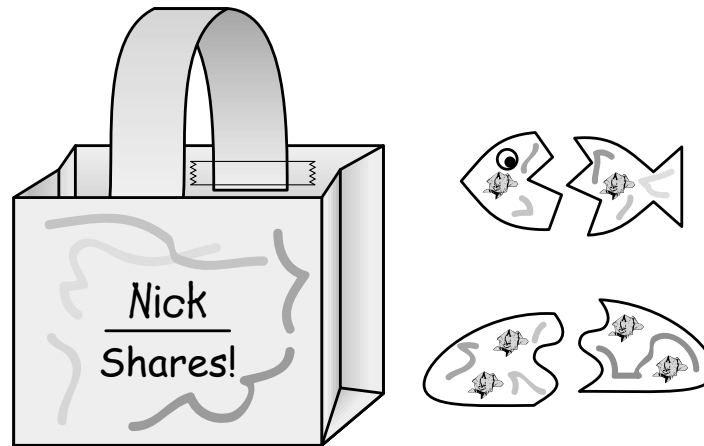

Figure B



Finished Craft





Lesson Objectives

- The children will identify what the boy shared with Jesus.
- The children will role play sharing.
- The children will sing about sharing.

Bible Story Text

John 6:1-13

Bible Truth

Share with others.
(Hebrews 13:16)

Preclass Centers

As the children arrive, guide them to a pre-class center. Have no more than six children at each center.

Materials

Use the materials previously selected for this unit's preclass centers.

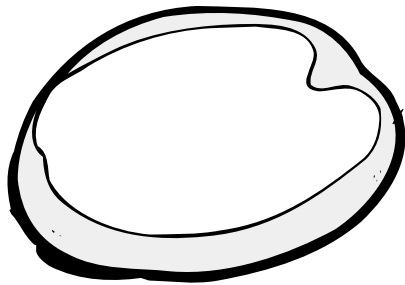

I Love to Share

Sharing

Lesson 2

Lesson Plan

Greeting and Registration

Preclass Activity: Preclass Centers

Welcome and Singing

Centers:

Life Application: Fish Sharing

Bible Story: A Boy Shares His Lunch

Craft: Cookies to Share

NOTE: Be sure to allow sufficient time for a snack.

Preparation

1. Be sure to check the condition of the materials selected for this unit's preclass centers prior to set up. Replace any broken toys, or puzzles with missing pieces as necessary.
2. Set up the centers before the children come into the classroom.
3. Assign a teacher to each center and have the teachers stay in those centers until the singing begins.

Instructions

Guide the play in each center reinforcing the unit theme.

Teacher Tips

- **IMPORTANT:** Do not allow any small toys in the classroom. First check all toys for size. You can obtain a "safety cylinder" from a pediatrician. Any object that can fit into the cylinder is too small and could cause a child to choke.
- Be involved in the group play and offer guidance as needed.
- Wear comfortable clothes suitable for sitting on the floor.
- Smile! Be childlike in heart and alert in mind.

Fish Sharing

The children will enjoy “fishing” and then sharing their “catch” with their friends.

Bible Truth

“Share with others.”
(Hebrews 13:16)

Materials

For the teacher:

- Bible
- fishing pole and fish from Unit 10 Lesson 1, Life Application
- clean bucket or small trash can

Preparation

1. Put all fish in bucket or small trash can.
2. Familiarize yourself with the activity and songs.

Instructions

Have the children take turns fishing until they each have two fish. **IMPORTANT:** Supervise the children carefully as they use the fishing pole so that no one accidentally gets hurt.

While the children are fishing, sing “I’m a Fish” and “I Wish I Were a Fish” from the Unit 10 Song Sheet.

Open your Bible. Ask the children, *Somebody in the Bible shared his lunch with Jesus. Do you know who it was? That’s right! A little boy. Do you know what was in his lunch? Hold up five fingers. He had five loaves of bread. Count on your fingers. One...two...three...four...five! What else did he have for his lunch? Right, he had some fish. Does anyone know how many fish the boy had? Hold up two fingers. That’s right! He had two fish! We are going to share our fish, just like the boy in the Bible shared his fish.*

I Love to Share

Sharing Lesson 2

Look at the colors of fish that each child has. Ask each child: *What colors are your fish?* Help the children identify the colors as needed. After you have asked each child, go back to the first child. If that child has two of the same color fish say, *you have a match. She has two orange fish. Can you show everyone your two matching fish?* Pick a child without matching fish. *You have one red fish and one yellow fish. Does someone else have a red fish? Will you share your red fish? Thank you!* Have the children exchange colors until each child has a matching pair of fish.

Sing the first verse of “We Like to Share Our Fish” from the Unit 10 Song Sheet. As you sing, help the children put their fish back into the bucket.

Bible Truth Activity

Open the Bible. *The Bible says, “Share with others.” Let’s all say that together. “Share with others.”*

Ask each child what they like to share with their friends. Help by making suggestions if they can’t think of anything. If there is time sing “We Like To Share Our Fish” from the Unit 10 Song Sheet. Substitute what the children mention in place of “fish,” for example sing, *We like to share our toys.*

Conclusion

Say a short prayer with the children to ask God to help us share.

Teacher Tips

Some of the children will not know their colors. Be very encouraging with anyone who needs help.

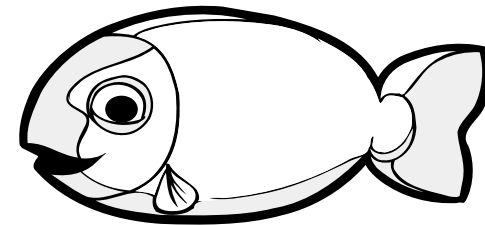

A Boy Shares His Lunch

The children will learn the Bible story by sharing bread and fish.

Bible Story Text

John 6:1-13

Materials

For the teacher:

- Bible
- paper bread and fish from the Unit 10 Lesson 1, Bible Story
- 1 large basket
- 1 small basket
- 1 loaf of sliced bread
- fish-shaped crackers

Preparation

1. Place the paper bread and fish shapes into the small basket.
2. Prepare the food as follows:
 - A. Cut each slice of bread into quarters.
 - B. Place the bread and the fish crackers into the large basket.
3. Familiarize yourself with the story and the songs.

Instructions

Place the baskets behind you as you sit with the children. Open your Bible and begin to tell the story.

Point to your eyes and say, *Many people came to see Jesus. Cup your hands behind your ears and say, Many people came to hear Jesus teach. Jesus would teach for a long time. The people would start to get hungry. Rub your stomach and say, Jesus wanted to give them something to eat. Jesus asked his friends, "Do you have some food to share?"* (John 6:5). Look at each child and show your empty hands while shrugging your shoulders as you ask each child, *Do you have any food to share?* After you have asked each child, shake your head and sigh, saying, *Jesus' friends did not have any food, and we don't have any food either.*

Show the small basket. With an excited voice say, *One of Jesus' friends, Andrew, said "This little boy wants to share his food!"* (John 6:8) Show the paper bread and fish. Say, *The little boy had five loaves of bread and two fish. Let's count them: one fish, two fish!* Do the same with the bread.

Say to the children, *Jesus' friends said, "This is still not enough*

I Love to Share

Sharing Lesson 2

for everyone." Look sadly at the children and shake your head.

Fold your hands as if you are praying and say, *So Jesus prayed, and guess what happened? They began to share the food with all the people and soon there was enough for everyone!*

Bring out the large basket and say, *We have bread and fish crackers to share! I'm going to pretend to be the little boy and I want to share my bread with you.* Ask each child if he or she would like to share your bread.

Pass the basket to a child and ask, *Would you like to pretend to be the little boy and share the fish crackers with everyone?* Let each child take a turn.

Sing "We Like to Share Our Fish" from the Unit 10 Song Sheet.

Conclusion

It makes Jesus, God and our parents happy when we share. Let's pray to thank God for all the things he gives us that we can share with others. Say a short prayer with the children.

Teacher Tips

IMPORTANT: Be sure that none of the children have allergies to any of the snacks you may serve during this activity. Ask the parents at registration if their child has any food intolerance or food allergies.





Cookies to Share

The children will prepare gifts for their friends.

Materials

For each child:

- white paper plate, 9"
- 2 cookies (not easily broken)
- plastic sandwich bag
- markers or crayons
- glue stick

For the teacher:

- tape
- black marker

Reproducible Pages:

- Page B, 1 copy for each child

Preparation

1. Cut out the sharing poem from the copies of Reproducible Page B.
2. Print "Cookies To Share" along the top rim of each plate.
3. Place two cookies into a plastic sandwich bag for each child.
4. Make a model of the craft following the instructions.

Instructions

1. Show the children the plate of cookies and say, *I have a cookie for me and a cookie to share! Would you like to share a cookie with someone too? Do you have a friend who would like a cookie? What is your friend's name? Let's make a cookie plate that you can share with your friend!*
2. Give each child a plate and some crayons. Have them color their plates.
3. Give the children the sharing poems and have them glue these near the bottom of their plates. See Figure A.
4. Give the children their bags of cookies. Have them tape the bags to their plates above the sharing poems. See Figure B.

I Love to Share

Sharing Lesson 2

Conclusion

Discuss sharing with the children. *You can keep one cookie and give one to a special friend. Which of your friends would like a cookie?*

Help them pick a person to receive the cookie.

Talk about how much fun it will be to give our friends the cookies. It makes God happy when we share.

Teacher Tips

- **IMPORTANT:** Be sure that none of the children have allergies to any of the snacks you may serve during this activity. Ask the parents at registration if their child has any food intolerance or food allergies.
- If place of plastic sandwich bags, you may also use plastic wrap or tissue paper and ribbon to tie the ends together.
- Cut out the sharing poems with pinking shears to make a decorative edge.

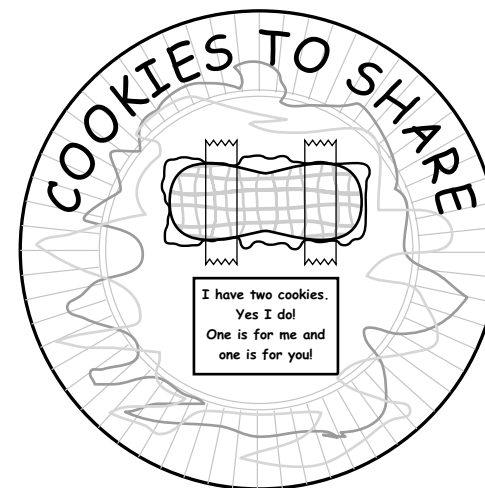

craft



Figure A

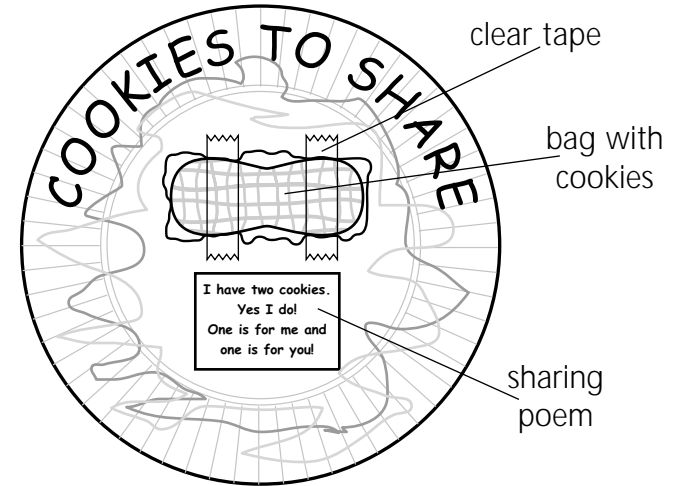
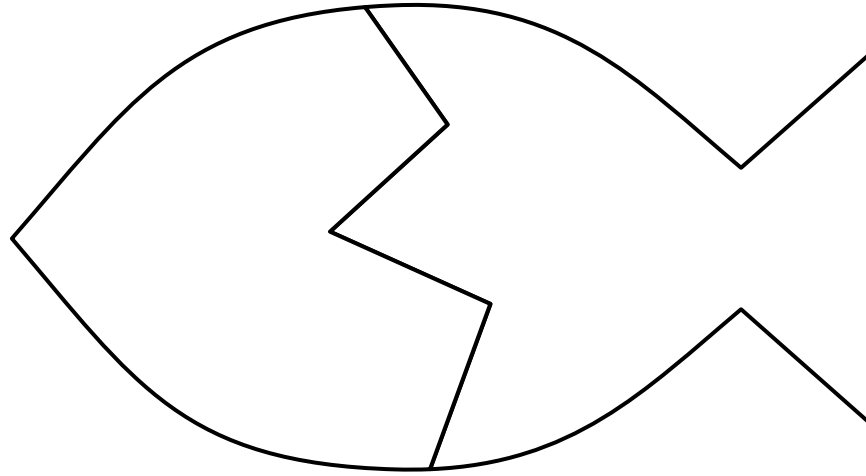

Figure B





R
e
p
r
o
d
u
c
i
b
l
e



fish

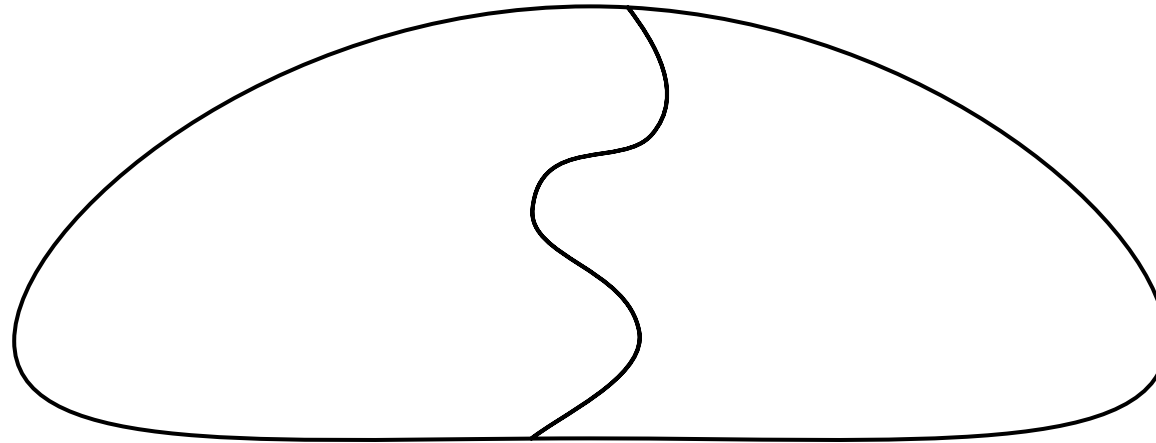

loaf





R
e
p
r
o
d
u
c
t
i
o
n

I have two cookies.
Yes I do!
One is for me and
one is for you!

sharing note

