

# My Parents Love Me

## Lesson Objectives

- The children will state that Cain was Adam and Eve's first baby.
- The children will state that God wants them to obey their parents.
- The children will thank God for giving them families.

## Bible Story Text

Genesis 4:1; Exodus 20:12;  
Colossians 3:20; Ephesians 6:1

## Bible Truth

Obey your parents.  
(*Ephesians 6:1*)

## Lesson Plan

Greeting and Registration

Preclass Activity: Preclass Centers

Welcome and Singing

Centers:

Bible Story: The Baby

Life Application: Learn to Obey

Craft: Baby Wrap

NOTE: Be sure to allow sufficient time for a snack.



# My Parents Love Me

## Preclass Centers

In the preclass centers children will use language, motor, and cognitive skills, learn to interact with peers and cooperate in small groups.

Select four centers to use this unit. Assign a teacher to set up and supervise each center with no more than six children.

### Materials

**IMPORTANT:** Do not allow any small toys in the classroom. First check all toys for size. You can obtain a "safety cylinder" from a pediatrician. Any object that can fit into the cylinder is too small and could cause a child to choke.

- Housekeeping Center—2 washable dolls (of diverse ethnicity, e.g., black and white), play food, dishes and 2 small blankets
- Story Center—simple books with limited text (cardboard are the most sturdy and durable) and large pillows
- Block Center—set of large blocks, people, animal figures (plastic or wooden) and toy cars
- Puzzle Center—1 puzzle for each child (for twos each puzzle piece itself should be a complete familiar object, for threes most can complete a 20-piece puzzle). **NOTE:** A puzzle should have all the pieces. If a puzzle piece is lost, the entire puzzle should be thrown out.

### Instructions

Guide the play in each center reinforcing the unit theme. Refer to the following example for help in directing play and asking relevant questions.

In the Housekeeping Center, ask the children: *In our Bible story today Adam and Eve have a baby. They are the baby's parents. Do you have parents? Let's pretend that we are the parents of these babies.*

### Teacher Tips

- You may want to try other centers such as transportation, large motor or manipulative.
- Wear comfortable clothes suitable for sitting on the floor.

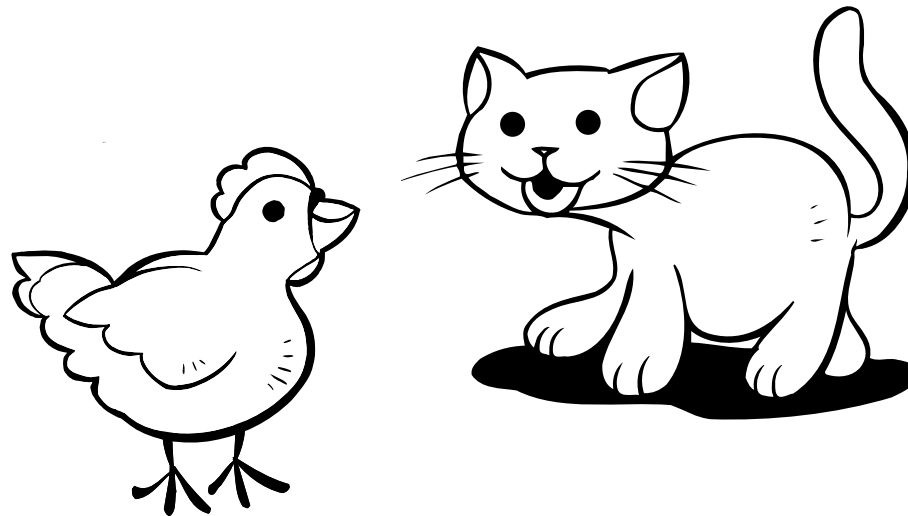

# My Parents Love Me

## The Baby

The children will hear the Bible story of the first baby ever born.

### Bible Story Text

Genesis 4:1; Exodus 20:12; Colossians 3:20; Ephesians 6:1

### Materials

*For the teacher:*

- crayons or markers
- baby doll
- small blanket

*Reproducible Pages:*

- Page A, 1 copy for the teacher
- Page B, 1 copy for the teacher

### Preparation

Color the copies of Reproducible Pages A and B.

### Instructions

Show the children the picture of Adam and Eve in the garden. *God made the whole world. He made all the animals in the world. Do you remember some of the animals that God made?* Encourage the children to name some animals. *God made the first people in the world. He made a man. What was the man's name? Yes, that's right, Adam. Then he made a wife and helper for Adam. Does anyone remember her name? Right, her name was Eve. Adam and Eve lived in a beautiful garden that God made for them.*

*One day, Adam and Eve had a little baby. Show the picture of Adam and Eve with the baby. The baby's name was Cain. Do you see Cain in this picture?* Let the children identify Cain, Adam and Eve. *Do any of you have a baby brother or sister at your home?* Let the children respond.

Bring out the doll and the blanket. Gently wrap the blanket around the doll as the children watch. *Let's sing a song and put the baby to sleep.* Sing "Baby Cain" from the Unit 9 Song Sheet.

Have the children take turns wrapping the baby in the blanket and rocking it as you sing the song a few times.

*We wrap the baby with a blanket to keep him warm. What else do mommies and daddies do to take care of their babies? Yes, they change diapers, feed them and put them to bed. Adam and Eve did all these things for their baby, Cain. Your mommies and daddies did all these things for you, too, when you were a baby. God's plan is for mommies and daddies to take care of their children. What ways do your mommies and daddies take care of you? Help the children to think through their answer (provide food, clothes, a house to live in, take care of me when I'm sick, take me to Bible class).*

NOTE: Save the teaching pictures for Unit 9 Lesson 2, Bible Story.

### Conclusion

*God made the world and everything in it. He made all the animals and people in the world. God made Adam and Eve and the first baby. Do you remember the baby's name? Yes, it was Cain.*

### Teacher Tips

Laminate the teaching pictures to help them last longer.



# My Parents Love Me

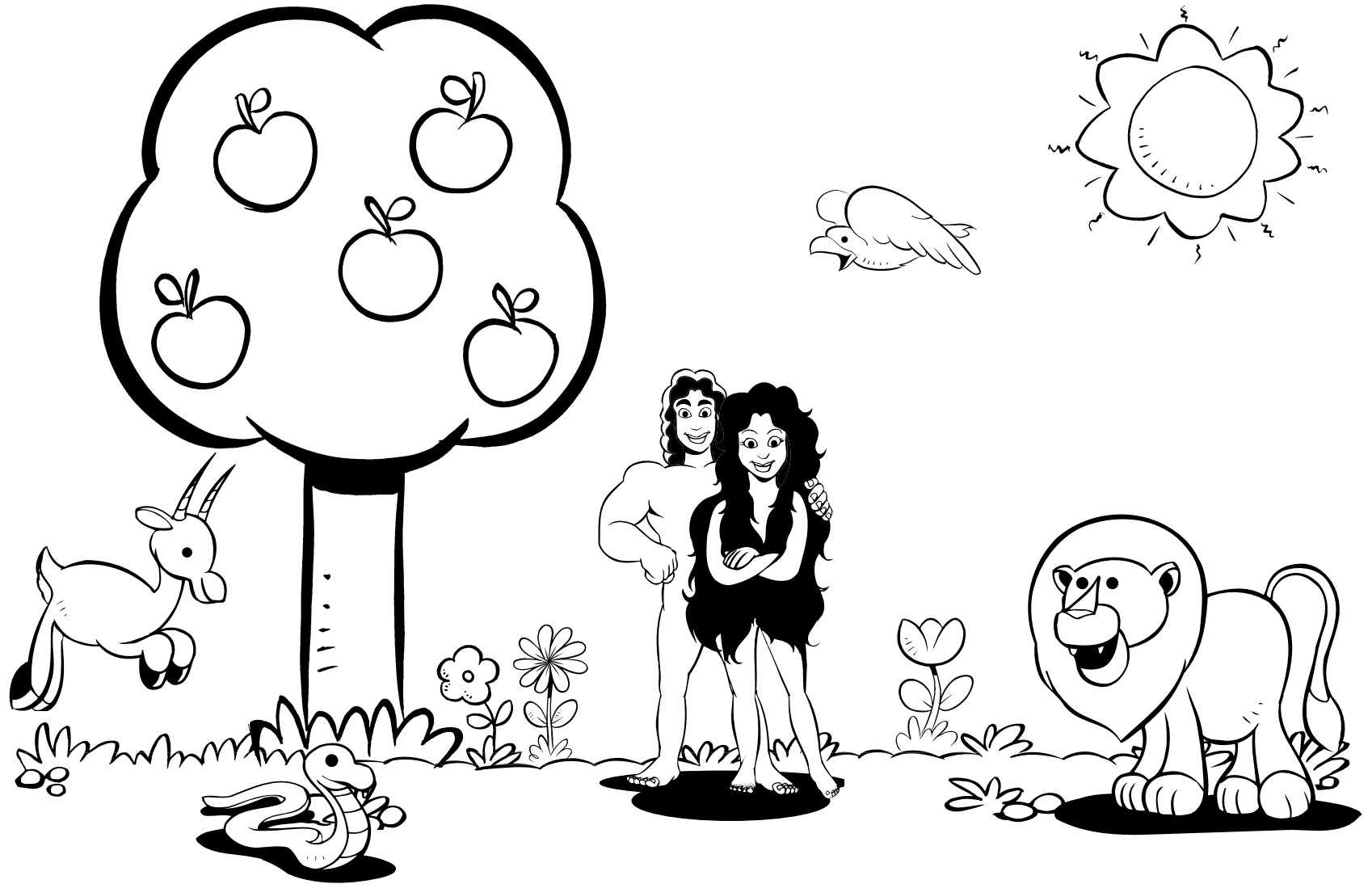

# My Parents Love Me

## Learn to Obey

The children will learn about obeying their parents and other grownups who take care of them.

### Bible Truth

Obey your parents.  
(Ephesians 6:1)

### Materials

For the teacher:

- felt board
- crayons or markers
- tape

Reproducible Pages:

- Page C, 1 copy for the teacher

### Preparation

1. Cut out and color the felt board figures from the copy of Reproducible Page C.
2. Familiarize yourself with the songs and the activity.

### Instructions

Introduce David, Lesli, Mom and Grandma. Sing "My Own Loving Family" and "I Love My Grandma" from the Unit 9 Song Sheet.

(Put the Mom figure on the felt board.) *"David and Lesli," Mommy called. "Come inside for a minute. I need to talk to you." "OK," said David and Lesli running into the house. (Put David and Lesli on the felt board.)*

*"I am going out shopping today, and Grandma is coming to take care of you. She said if you obey her this morning, she will take you to the park when you wake up from your nap.*

*"Yippee!" said Lesli. "Yeah!" said David. They loved when their grandma took care of them, and they especially loved it when she took them to the park. David liked to swing and slide and run on the playground. Lesli liked to feed the ducks.*

*Soon Grandma drove up. David and Lesli ran out to meet her. (Put Grandma on the felt board.) She hugged them both. "I am so happy to see you!" she said. "My, how tall you are both growing!"*

*Mommy spoke to David and Lesli. "Look in my eyes," she said. "Are you going to obey your grandma?"*

*"Yes! Yes!" they answered.*

*"Remember," she said, "If you obey Grandma, you can go to the park after your nap."*

*"We will remember," they said. (Take Mom off the felt board.)*

*But they did not obey. They fought over David's new ball.*

*"David, you play with the new blue ball, and Lesli, you play with the red ball. In a few minutes I will tell you when it is time to trade," said Grandma.*

*"No!" said Lesli. "I don't want to play with the dirty old red ball!"*

*"No!" said David. "I don't want to let her play with my new blue ball."*

*"Children," said Grandma, "this is not obeying. You need to obey and share your toys." But they did not obey. (Take David and Lesli off the felt board.)*

*Then it was time to eat lunch. "Come inside," Grandma called. "It is time to wash your hands." Grandma poured the milk and sliced the apples, but David and Lesli did not come in. "David! Lesli!" she called, "please come inside!" Grandma put the sandwiches on their plates. David and Lesli still did not come in. (Put David and Lesli back on the felt board.) Finally, Grandma walked outside and took David by one hand, and Lesli by the other hand and looked in their eyes. "Children," she said, "this is not obeying. You need to obey and come the first time you are called."*

*After lunch, Grandma said, "You may each choose one book to look at before you take your nap." Did they obey? No, they did not. Lesli took two books, and David took three.*

*After their nap, David and Lesli came running out of their room. "Grandma, Grandma, it's time to go to the park!" they shouted excitedly. "It is time to swing and slide and run on the playground," said David. "It is time to feed the ducks," said Lesli. "I will get the bread."*

*"Wait," said Grandma. "I want you both to sit down on the couch. I have to talk to you. Grandma opened the Bible and read, "Children obey." Then she looked at David and Lesli. "Do you remember what happened this morning with the balls?" she asked. "Yes," they said. "Did you obey me and share the balls?" "No," they said. "Do you remember what happened when I called you inside for lunch?" she asked. "Did you obey me and come inside?" "No," they said. "And what about at nap time when I told you to get one book to take to your beds, did you obey me then?" "No," they said very slowly, looking down at the floor.*

# My Parents Love Me

*"So what do you think? David, will you get to play on the playground today?" she asked him.*

*"No, Grandma," he said as a tear rolled down his face.*

*"What about you, Lesli?" she asked. "Will you get to feed the ducks?"*

*"No," she said, starting to cry.*

*"What do you need to say to Grandma?" she asked them both.*

*"I'm sorry," said David.*

*"I'm sorry," said Lesli.*

*"I forgive you and I love you. What are you going to do the next time Grandma tells you something?" she asked.*

*"We will obey," they said.*

*"Why don't we play one of your games until Mommy gets home" Grandma said.*

*"OK," they both said and ran to get a game. They played the game, and they remembered to obey Grandma all afternoon.*

*Soon Mommy came home. She looked surprised. "You are not at the park?" she said.*

*"No, Mommy," they said. "We did not obey Grandma, and we did not get to go to the park. But we are very sorry. We obeyed Grandma all afternoon."*

*"I am sad that you did not obey Grandma this morning, but it is great that you changed and obeyed after your naps," said Mommy.*

*"I was thinking," said Grandma. "If it's OK, I could come back one day next week. If David and Lesli obey me, then we could go to the park."*

*"Oh, could we? Could we?" asked the children.*

*"I think that will be fine," said Mommy, smiling. "Except for one thing. What is it that you both need to remember?" she asked.*

*Ask the children; What do you think they need to remember? That's right, they need to remember to obey. Do you think they will remember?*

*NOTE: Save the felt board figures for Unit 9 Lesson 2, Life Application.*

## Bible Truth Activity

*God says, Obey your parents. Let's all say that together, "Obey your parents." When grownups take care of you, you need to obey them. Who are the grownups who take care of you? Who took care of David and Lesli? Their grandma. Let's all say, "Obey your grandma." What about your teacher? Let's all say, "Obey your teacher." What about your baby-sitter? Let's all say, "Obey your baby-sitter." God wants us to love and obey the grownups who take care of us!*

## Conclusion

*It makes God very happy when we obey him. It makes him happy when we obey the grownups that take care of us. Let's pray and thank God. Thank you, God, for the grownups that you give us to take care of us. Please help us to obey the first time we are asked to do something.*

*Can you tell someone about our Bible class today? How about one of the grownups who takes care of you? They will be happy to learn that you want to obey them.*

## Teacher Tips

- If you have all twos, you can simplify or shorten the story as needed.
- Cut out pictures from magazines and tape them to the felt board as props.
- Animate the figures by moving them as you tell the story.
- Place the felt board in front of you as you tell the story; this will help you to move the figures easily.
- Laminate the felt board figures to help them last longer.

# Craft

## My Parents Love Me

### Baby Wrap

This children will make textured pictures of the baby Cain.

#### Materials

*For each child:*

- 1 piece of soft fabric, 5" x 9"
- glue stick

*For the teacher:*

- scissors
- marker

*Reproducible Pages:*

- Page D, 1 copy for each child
- Page E, 1 copy for the teacher

#### Preparation

1. Cut out each Cain picture from the copies of Reproducible Page D. Refer to Figure A.
2. Fold each picture as follows:
  - A. First fold the side panels in along the dotted lines so they meet. See Figure B.
  - B. Then fold the top panels down so Cain's head shows. See Figure C.
3. Cut out the fabric stencils from the copy of Reproducible Page E.
4. For each child, trace and cut out one nightgown and two covers from the fabric.
5. Make a model of the craft following the instructions.

#### Instructions

1. Show the children your model. Explain that this is Cain, the first baby ever born.
2. Give each child a Cain picture. Have the children unfold their papers to see the picture of the baby.
3. Give each child a nightgown to glue onto the "baby." See Figure D.
4. Have the children refold their pictures, and then glue the covers onto the fronts of the side panels, as shown in Figure E.
5. Have the children pick up their "babies," and then rock them as you sing "Baby Cain" from the Unit 9 Song Sheet.

#### Conclusion

Talk about the baby that God gave to Adam and Eve. Tell the children that God invented families.

Say a short prayer thanking God for families.



craft

# My Parents Love Me

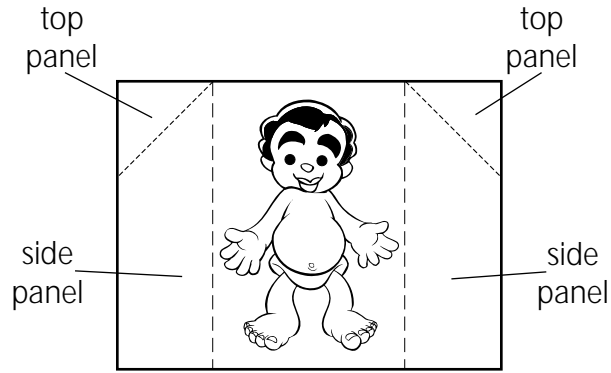

Figure A

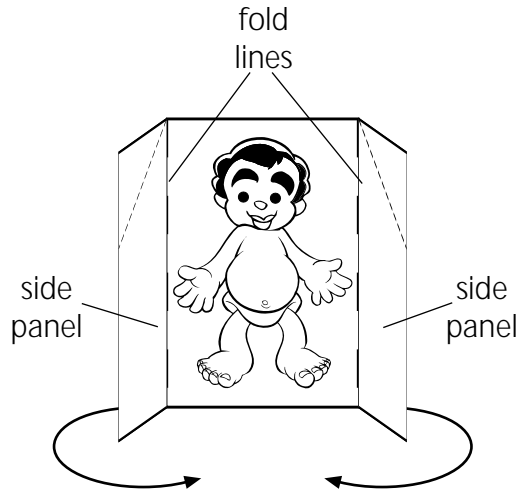

Figure B

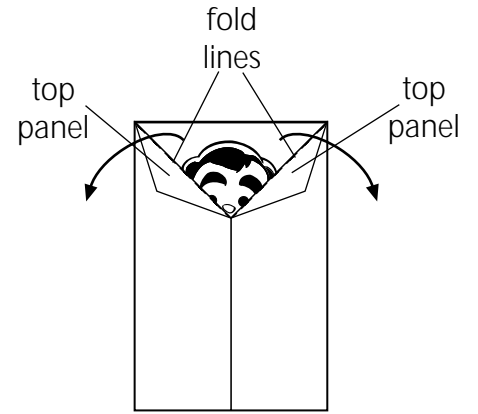

Figure C

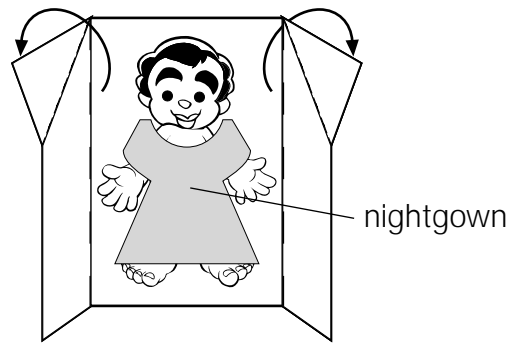

Figure D

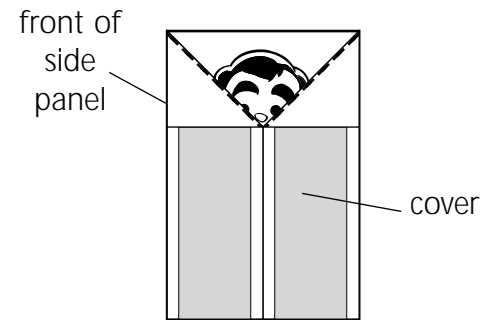

Figure E







# My Parents Love Me

## Families

Lesson 1

### Lesson Objectives

- The children will state that Cain was Adam and Eve's first baby.
- The children will state that God wants them to obey their parents.
- The children will thank God for giving them families.

### Bible Story Text

Genesis 4:1; Exodus 20:12; Colossians 3:20; Ephesians 6:1-4

### Bible Truth

Obey your parents.  
(*Ephesians 6:1*)

### Preclass Centers

In the preclass centers children will use language, motor and cognitive skills, learn to interact with peers and cooperate in small groups.

Select four centers to use this unit.

Assign a teacher to set up and supervise each center with no more than six children.

#### Materials

**IMPORTANT:** Do not allow any small toys in the classroom. First check all toys for size. You can obtain a "safety cylinder" from a pediatrician. Any object that can fit into the cylinder is too small and could cause a child to choke.

- Housekeeping Center—2 washable dolls (of diverse ethnicity, e.g., black and white), play food, dishes and 2 small blankets

### Lesson Plan

Greeting and Registration

Preclass Activity: Preclass Centers

Welcome and Singing

Centers:

Life Application: Happy or Sad

Bible Story: The Baby

Craft: Thank You, Dad

NOTE: Be sure to allow sufficient time for a snack.

- Story Center—simple books with limited text (cardboard are the most sturdy and durable) and large pillows
- Block Center—set of large blocks, people, animal figures (plastic or wooden) and toy cars
- Puzzle Center—1 puzzle for each child (for twos each puzzle piece itself should be a complete familiar object, for threes most can complete a 20-piece puzzle). NOTE: A puzzle should have all the pieces. If a puzzle piece is lost, the entire puzzle should be thrown out.

#### Instructions

Guide the play in each center reinforcing the unit theme. Refer to the following example for help in directing play and asking relevant questions.

In the Housekeeping Center, ask the children: *In our Bible story today Adam and Eve have a baby. They are the baby's parents. Do you have parents? Let's pretend that we are these babies' parents.*

#### Teacher Tips

- You may want to try other centers such as transportation, large motor or manipulative.
- Wear comfortable clothes suitable for sitting on the floor.

Life

Application

## Happy or Sad

The children will learn how their behavior makes other people and God feel.

### Bible Truth

Obey your parents.  
(Ephesians 6:1)

### Materials

For each child:

- 1 paper plate
- 1 craft stick

For the teacher:

- marker
- masking tape
- Bible

### Preparation

1. Draw a happy face on one side of each plate.
2. Draw a sad face on the other side of each plate.
3. Tape a craft stick to the bottom of each plate for a handle.

### Instructions

Show the children the Bible. *Do you know what this is? That's right! It is the Bible! Do you know who wrote the Bible? God did! Open the Bible. We sometimes read stories and watch cartoons that are pretend, but the Bible is not pretend! The Bible is real! It is true. Everything in it really happened. God wrote the Bible and gave it to us so we can learn from it!*

*The Bible says, "Obey your parents." Who are your parents? Your parents are your daddy and your mommy. You should obey the grownups who take care of you. Mary, who takes care of you?*

*What about you, John, who takes care of you? Ask each child who takes care of them.*

*Can you say, "obey your parents" with me? Let's all say it together: "Obey your parents." Kurt, when your Mommy says, "pick up your toys," do you obey? When you pick up your toys you are being obedient. It makes God and your Mommy happy when you obey. Hold up the happy face.*

*How does your mommy look when you obey? Does she give you a big smile? Can everyone show me a big smile?*

*What about if you do not obey? When your mommy says, "pick up your toys." And then you say, "No!" Are you obeying? No. How does Mommy look when you don't obey? She looks sad, doesn't she? Hold up the sad face.*

Hand out the paper plate faces to the children and show them both sides. Practice making happy and sad faces together.

Sing "This Is the Way My Mommy Looks" from the Unit 9 Song Sheet.

NOTE: Collect the paper plate props and save them for Unit 9 Lesson 2, Life Application.

### Bible Truth Activity

*The Bible says, obey your parents. Let's say it together: "Obey your parents." When we obey and do what mommy and daddy tell us to, it makes them happy and it makes God happy, too.*

### Conclusion

As time allows, ask each child, *Who is someone in your family that you love? What do you do to show them that you love them?* Help each child respond. If they need help remembering, use something from the song (give a hug, share my toys, go to bed, etc.).

End with a short prayer. *Dear God, please help us to obey our parents at home and to love our families.* Allow any children who would like to say a short prayer.

*Our families will be so happy when we tell them about what we are learning in Bible class. Who in your family can you tell about how you are learning to obey?*

### Teacher Tips

Children relate deeply to the song, "This Is the Way My Mommy Looks." A sensitive child may begin to cry because of the concept of making someone sad. If this occurs, switch to the "happy face" verses or sing instead, "If You're Happy and You Know It" from the Unit 9 Song Sheet.



## The Baby

The children will hear the story of the first baby born.

### Bible Story Text

Genesis 4:1; Exodus 20:12; Colossians 3:20; Ephesians 6:1

### Materials

*For the teacher:*

- crayons or markers
- baby doll
- small blanket

*Reproducible Pages:*

- Page A, 1 copy for the teacher
- Page B, 1 copy for the teacher

### Preparation

Color the copies of Reproducible Pages A and B.

### Instructions

Show the children the picture of Adam and Eve in the garden. *God made the whole world. He made all the animals in the world. Do you remember some of the animals that God made?* Encourage the children to name some animals. *God made the first people in the world. He made a man. What was the man's name? Yes, that's right, Adam. Then he made a wife and helper for Adam. Does anyone remember her name? Right, her name was Eve. Adam and Eve lived in a beautiful garden that God made for them.*

*One day, Adam and Eve had a little baby. Show the picture of Adam and Eve with the baby. The baby's name was Cain. Do you see Cain in this picture?* Let the children identify Cain, Adam and Eve. *Do any of you have a baby brother or sister at your home?* Let the children respond.

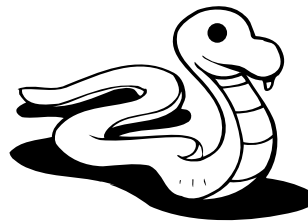

Bring out the doll and the blanket. Gently wrap the blanket around the doll as the children watch. *Let's sing a song and put the baby to sleep.* Sing "Baby Cain" from the Unit 9 Song Sheet.

Have the children take turns wrapping the baby in the blanket and rocking it as you sing the song a few times.

*We wrap the baby with a blanket to keep him warm. What else do mommies and daddies do to take care of their babies? Yes, they change diapers, feed them and put them to bed. Adam and Eve did all these things for their baby, Cain. Your mommies and daddies did all these things for you, too, when you were a baby. God's plan is for mommies and daddies to take care of their children. What ways do your mommies and daddies take care of you? Help the children to think through their answers (provide food, clothes, a house to live in, take care of me when I'm sick, take me to Bible class).*

NOTE: Save the teaching pictures for Unit 9 Lesson 2, Bible Story.

### Conclusion

*God made the world and everything in it. He made all the animals and people in the world. God made Adam and Eve and the first baby. Do you remember the baby's name? Yes, it was Cain.*

### Teacher Tips

Laminate the teaching pictures to help them last longer.

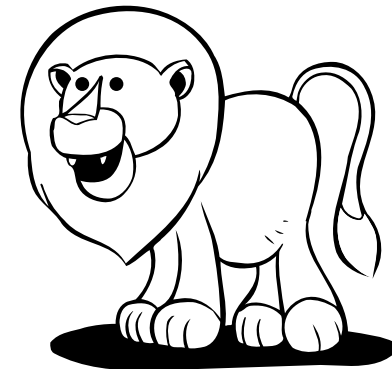

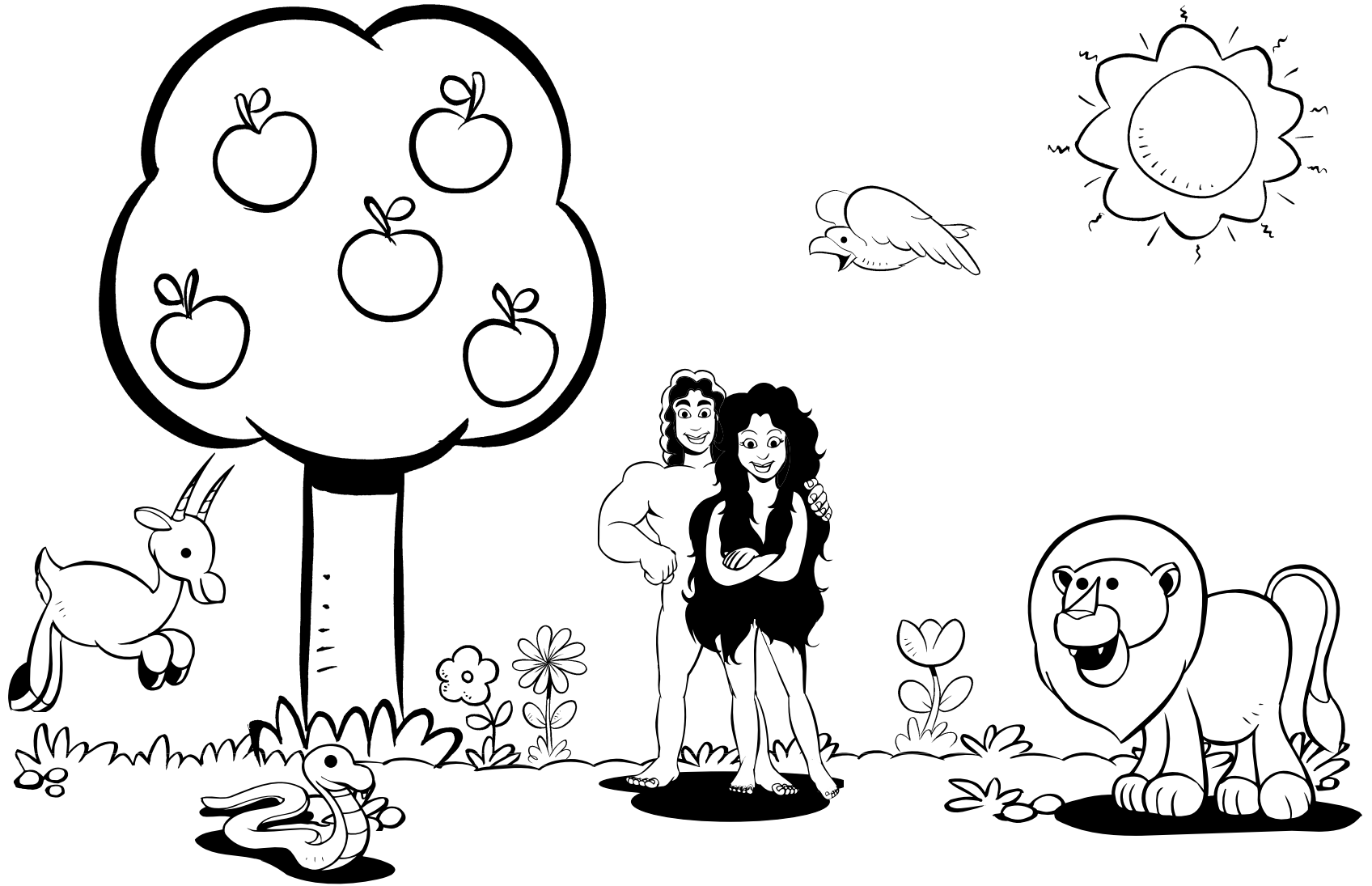

# Craft

## Thank You, Dad

The children will make cards to thank their fathers for all that they do.

### Materials

*For each child:*

- 1 piece of construction paper
- crayons

*For the teacher:*

- scissors
- ruler
- black marker

*Reproducible Pages:*

- Page F, 1 copy for each child

### Preparation

1. Cut out the interview sheets and the ties from each copy of Reproducible Page F.
2. Fold each piece of construction paper in half making a "card."
3. Measure and cut a 3" long "V" on the front cover of the card, as shown in Figure A.
4. Using a marker, draw a "shirt collar" on the front cover of each card as shown in Figure B.
  - A. Draw two 3½" straight lines from the top of the "V".
  - B. Draw two 1½" diagonal lines from ends of the straight lines to the point of the "V".
5. Make a model of the craft following the instructions.

### Instructions

1. Show the children the completed craft. *God has put daddies or other special men in our lives to take good care of us. This card is to thank them.*
2. Do an "interview" with each child and write their answers in the spaces provided. Write "Dad" or the appropriate person in the space in the "Thank You," heading.
3. Have the children glue the interview sheet on the inside of the card, as shown in Figure C.
4. Give each child a tie to color.
5. Have each child glue the tie under the collar of the shirt on the front of the card. See Figure D.
6. Have the children draw pictures of their dads under the interview questions.

### Conclusion

Talk about "daddies" and all the things they do for us. Say a short prayer thanking God for giving us daddies.

### Teacher Tips

A child in your class may not have a father to make a card for. Help them to choose someone else to make a card for such as a grandfather, an uncle or a friend.

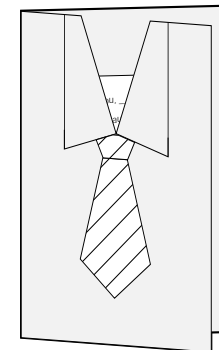
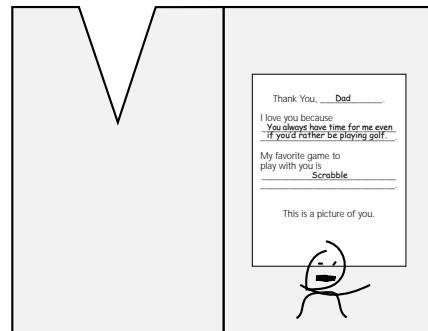

# My Parents Love Me

C  
r  
a  
f  
t

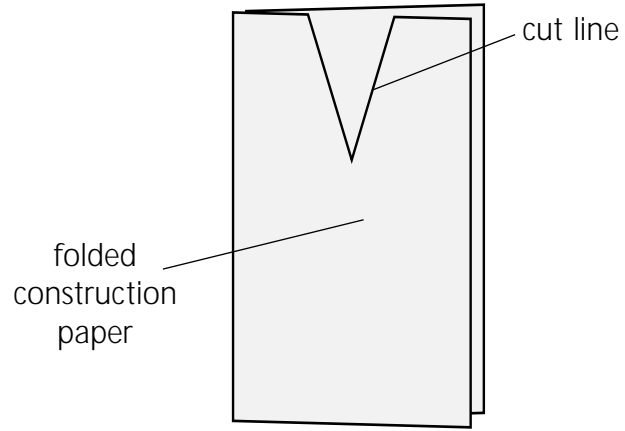

Figure A

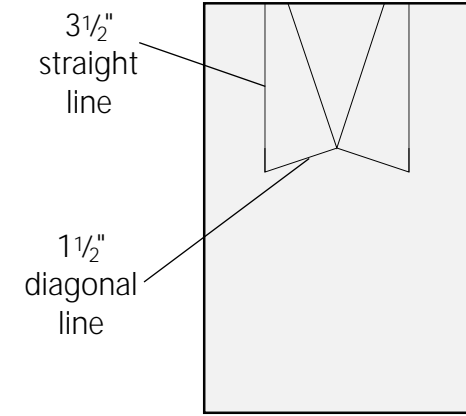

Figure B

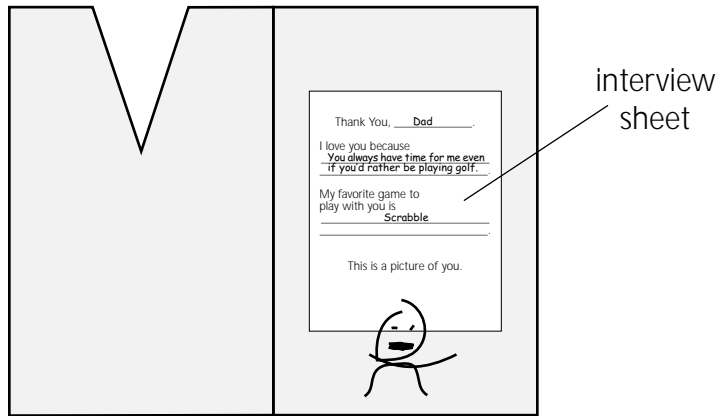

Figure C

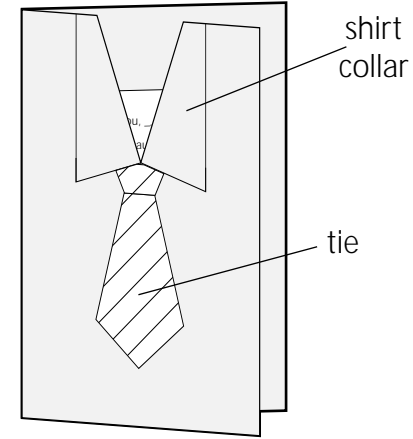
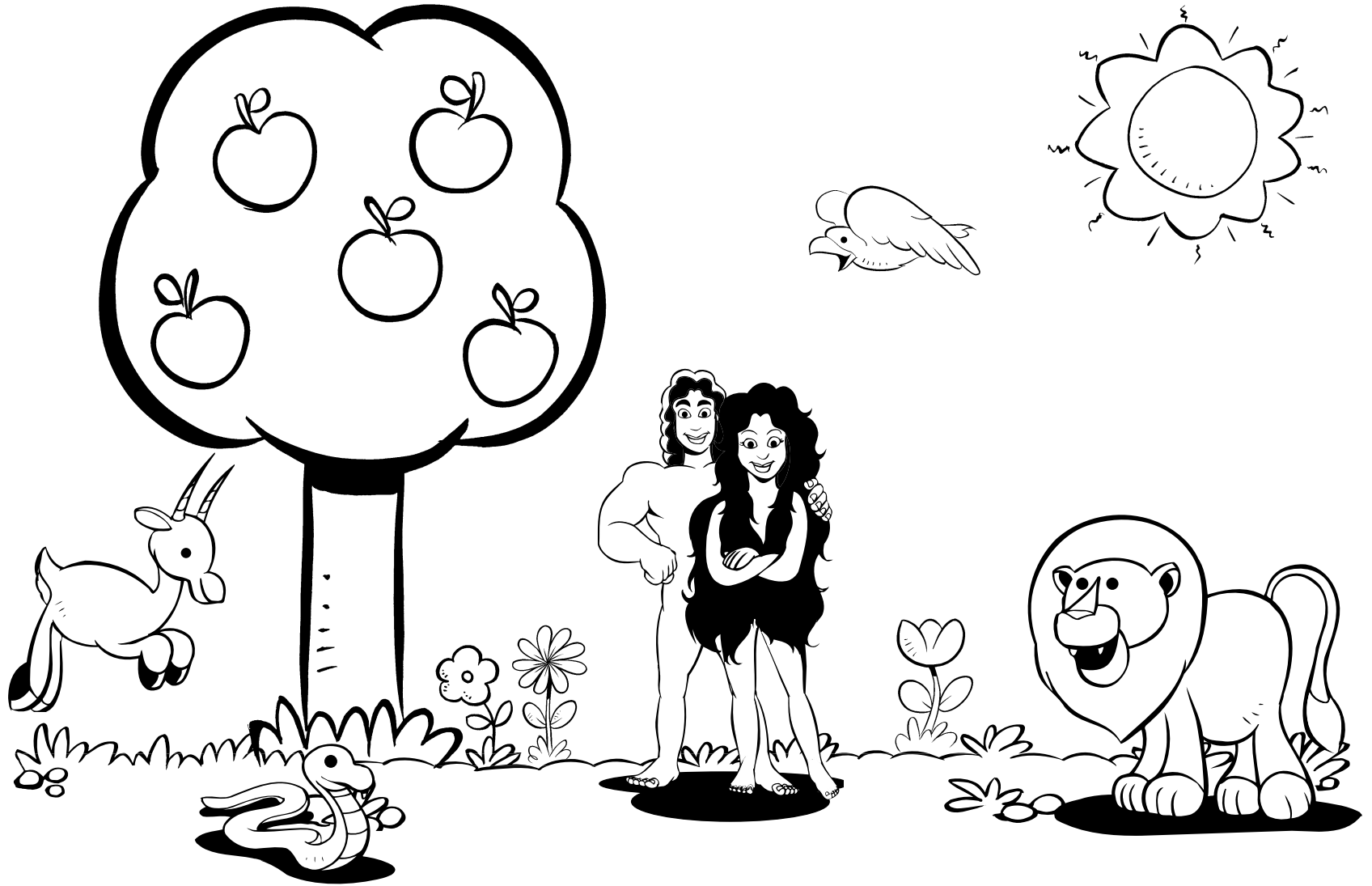

Figure D





R  
e  
p  
r  
o  
d  
u  
c  
i  
o  
n  
e



teaching picture





R  
e  
p  
r  
o  
d  
u  
c  
e  
d  
i  
n  
g

Core/Bible Story 1 copy for the teacher  
Supplement/Bible Story 1 copy for the teacher

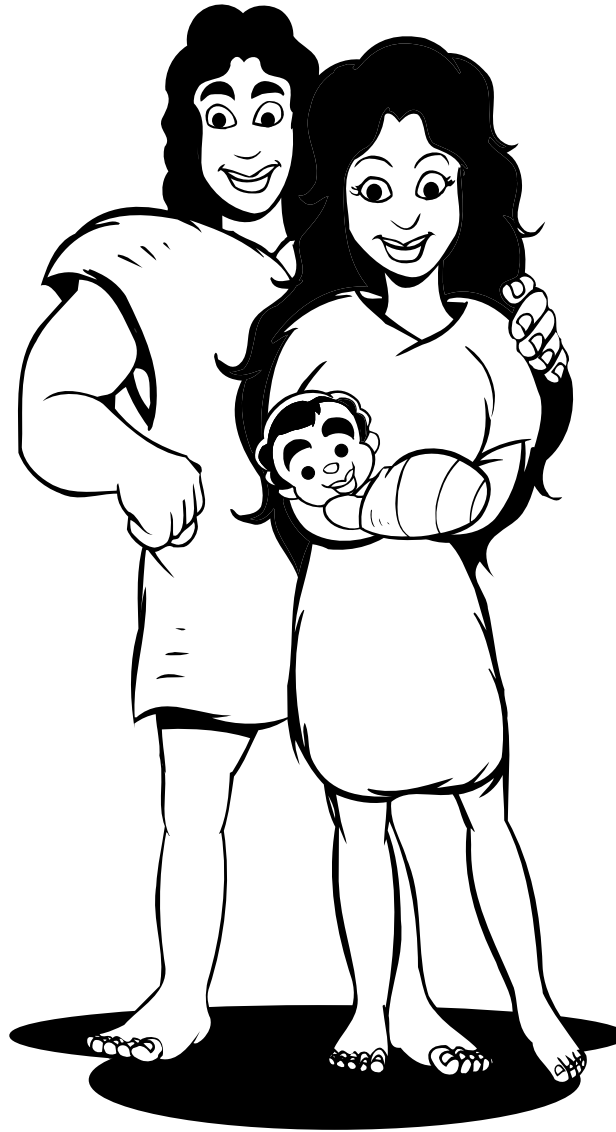

teaching picture







R  
e  
p  
r  
o  
d  
u  
c  
i  
o  
n  
e

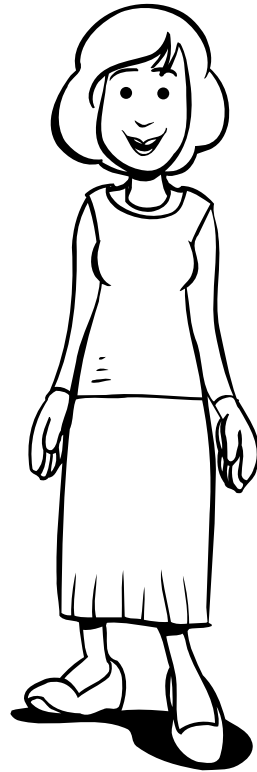

Mom



Grandmother



Lesli

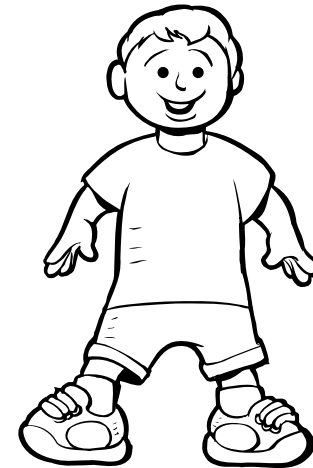

David





e-b-c-o-r-p-e-r

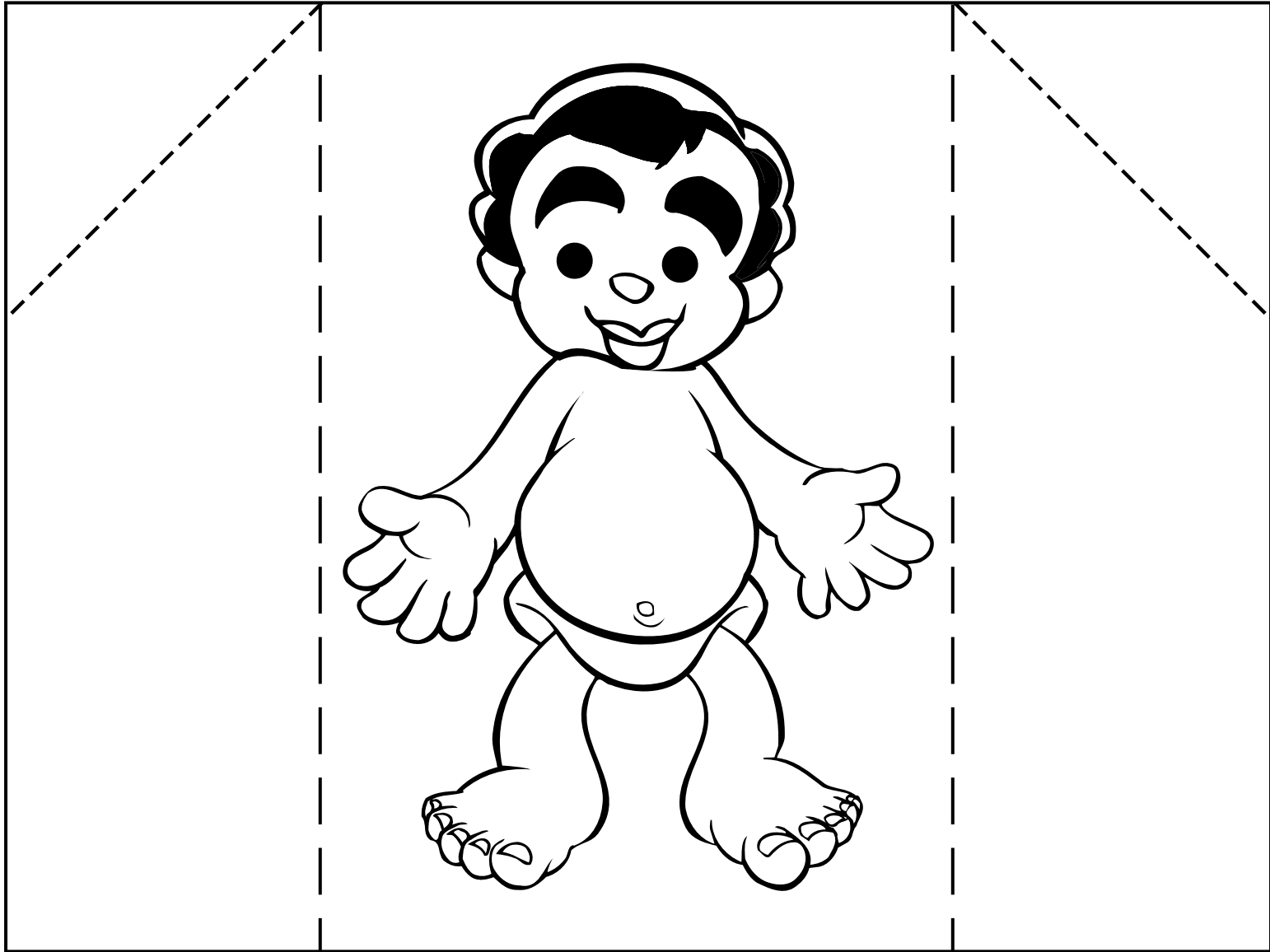

Cain picture





fabric stencils

R  
e  
p  
r  
o  
d  
u  
c  
i  
o  
n  
e

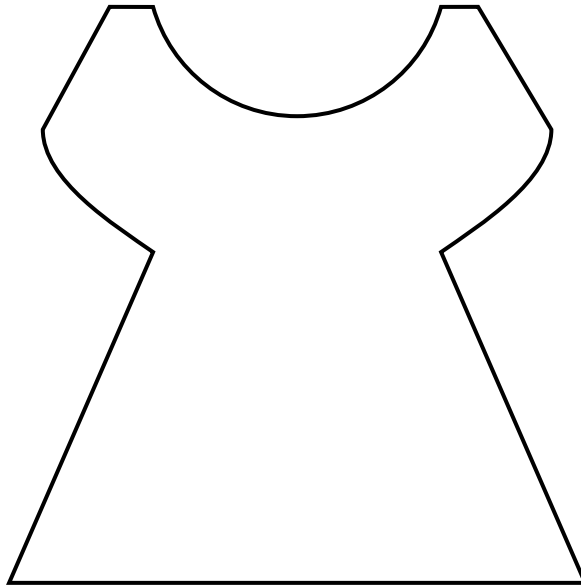

nightgown stencil



cover stencil





R  
e  
p  
r  
o  
d  
u  
c  
e  
d  
b  
y  
e

Thank You, \_\_\_\_\_.

I love you because

\_\_\_\_\_

\_\_\_\_\_.

My favorite game to play with you is

\_\_\_\_\_

\_\_\_\_\_.

This is a picture of you.

interview sheet

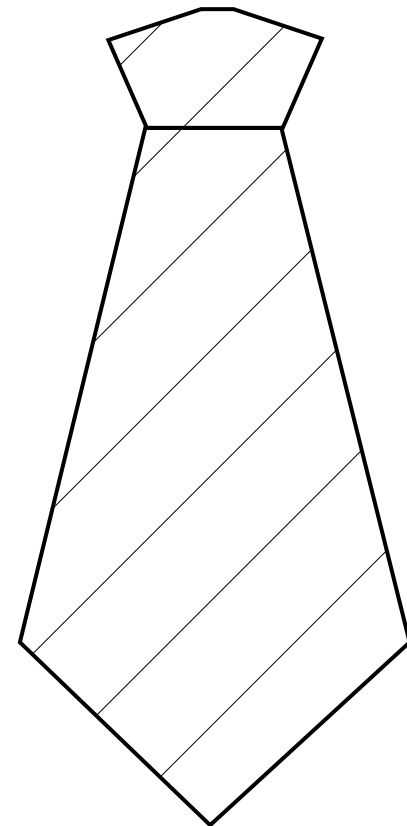

tie

