

# The Samaritan Woman

Jesus with People  
Lesson 4

## Lesson Objectives

- The children will tell the story of Jesus and the Samaritan woman.
- The children will identify the world sector for their church and mission.
- The children will tell one way they can help others know about Jesus.

## Lesson Text

John 4:1-42

## Scripture Memory Verse

Do not forget to do good and to share with others.

*Hebrews 13:16*

## Lesson Plan

Greeting and Registration

Preclass Activity: The Whole World

Welcome and Singing

Centers:

Bible Story: Well of Surprises

Craft: Telling Times

Scripture Memory: Pass It On

NOTE: Allow time for a snack.



### To the Core and Supplement Lead Teachers: Special Missions Lesson

The focus of this special missions lesson is to help the children become personally involved in the mission of their church and world sector. Visit your church's website or the website for the International Churches of Christ ([www.icoc.org](http://www.icoc.org)) to obtain current "good news" from your world sector. Talk to your Geographic Sector Leaders and local ministers. Become personally informed about the specific mission plantings and churches supported by your local congregation. Be ready to share this information with the children and other teachers in your class.

# The Samaritan Woman

## The Whole World

The children will preview today's Bible Story as they identify their church's world sector and mission.

### Materials

*For each child:*

- 1 foil star sticker
- crayons or markers
- pencil

*For the teacher:*

- large writing surface
- information about your world sector's mission plantings
- world atlas or globe (if available)

*Reproducible Pages:*

- Page A, 1 copy for each child

### Special Advanced Preparation

Obtain information about your world sector to share with the children. Locate pictures, travel brochures, books and artifacts from different countries in your world sector. Visit your church's website or the website for the International Churches of Christ ([www.icoc.org](http://www.icoc.org)) to learn about the mission work in your world sector.

### Preparation

1. Display information about your church's world sector and mission plantings for the children to look at when they arrive.
2. On the large writing surface, write the names of three mission plantings supported by your church or region.
3. Complete the activity on your copy of Reproducible Page A.

### Instructions

1. Greet the children as they arrive. Direct them to the information you have displayed. Explain that today's lesson has a special focus on world missions. Tell the children they will be learning about the churches and people that they help support.

2. Distribute the copies of Reproducible Page A, pencils and crayons. Show the children which world sector they belong to and have them color it in. Give each child a star sticker to place on the area on the map that represents your local congregation. For example: A child in Hartford, Connecticut would color in the New England and Europe areas of the map, and place a star on New England.
3. Refer the children to the mission plantings you listed on the large writing surface. Have them write these churches on their pages in the spaces provided.
4. Have the children write their names on their pages.
5. Circulate among the children to offer help and talk about the exciting things that God is doing in your part of the world.

### Teacher Tips

- Many stores sell inexpensive flags and flag stickers that you may be able to use for this activity.
- Invite former missionaries in your local congregation to come and visit your class today to talk about their experiences.
- Visit the children's section of your library for books and maps of the countries in your world sector.
- Visit your local travel agent to obtain picture brochures of places in your world sector.

**B****S****I****T****B****O****L****R****E****Y**

# The Samaritan Woman

Jesus with People  
Lesson 4

## Well of Surprises

The children will learn the story of the Samaritan woman and her surprising encounter with Jesus.

### Materials

For each child:

- 1 party noisemaker or horn

For the teacher:

- large writing surface
- permanent black marker
- a houseplant (optional)

### Preparation

1. On the large writing surface, write: Samaria.
2. Label each noisemaker with the child's name to avoid confusion or spread of germs.
3. Take a small cutting from your plant.
4. Practice presenting this Bible Story at home, with emphasis and conviction.

IMPORTANT: Do not allow the children to share a horn they put in their mouths.

### Introducing the Bible Story

Open your Bible to John 4:1-42. Tell the children that today's lesson comes from the New Testament book—or gospel—of John. *In your Preclass Activity, you learned about the churches and mission plantings for our world sector. A mission planting is when a small group of disciples go to a city where there is no church and plant a church. They begin small, like a small plant, but then God makes the church grow, like a big tree!* If available, show the children your plant. Explain that it started as a small "planting" like the cutting you made, but grew to be a big plant. This is how the church grows, too.

*Do you like surprises? I am so excited about today's lesson because it is full of surprises! You are going to learn that Jesus surprised a lot of people by what he said and how he helped one woman.*

Tell the children to look at the word on the large writing surface. Ask them to say it with you. Tell them that this story happened in a place called Samaria with a Samaritan woman. Explain this in relation to the town or city where the children live. For example: a person from Boston is a Bostonian, etc.

### Presenting the Bible Story

Distribute the noisemakers to the children. Tell them to listen very carefully as you tell the story. Every time they hear you say, "SURPRISE," they should blow their noisemakers. Then you will tell them the surprise. Encourage them that if they want to use their noisemakers, they can use them only when you tell them to. Otherwise, you will ask to have them back.

### The Disciples

*Jesus and his disciples were going to Galilee. The quickest way to get to Galilee was to go through a place called Samaria. Many Jewish people did not like Samaritans. In fact, they would not even go near the town of Samaria. But Jesus loved everyone. So do you know what? SURPRISE! Jesus went right through Samaria! His disciples were surprised that Jesus—who was Jewish—would go to Samaria. It was a long journey and Jesus was tired, so he sat down by a well called "Jacob's Well." Jesus asked his disciples to go into town to get some food.*

### The Woman

*While Jesus was resting, a woman came to the well to get some water. Jewish men did not speak to women out in the open. SURPRISE! Jesus spoke to the woman! He asked her for a drink of water. The woman was very surprised. She wanted to know why he was speaking to her and asking her for water. SURPRISE! Jesus told the woman that he had water to give to her—living water! The woman was even more surprised because Jesus did not have his own well or even a bucket! She asked him how he could give her water. SURPRISE! Jesus told the woman that he knew everything about her. She was even more surprised that a total stranger knew all about her thoughts and feelings—and still cared about her. Then she understood that Jesus was from God.*



# The Samaritan Woman

## The Disciples (Again)

*Listen to what the Bible says in John 4:27:*

*Just then his disciples returned and were SURPRISED to find him talking with a woman. But no one asked, "What do you want?" or "Why are you talking with her?" (Emphasis added.)*

*The woman was so excited that she ran back into town to tell the people about Jesus. Then the disciples gave Jesus some food and told him to eat. SURPRISE! Jesus told them that he had food they did not know about. The disciples were surprised. They thought that perhaps someone else had brought him something to eat. But Jesus said that his food was to tell others about God. The disciples had seen Jesus talking to the woman about God—even though she was a Samaritan. They understood that Jesus loved everyone, no matter where they came from.*

## The People

*The people of the town came out to see Jesus and learn from him. SURPRISE! They were surprised that he really was the one the woman had said. They begged Jesus to stay for two days to teach the people about God and he did. Many more people believed in Jesus after that.*

## Share and Tell

Ask the children to each share one of the surprises that they remember from the story. Help them review and retell it in their own words. Encourage them to take their noisemakers home and keep them in a place that will remind them of today's story. Collect the noisemakers from the children, returning them as they leave at the end of class.

Tell the children that Jesus still wants his disciples to tell everyone about him. Ask the children who they know that would be surprised if they were talked to about Jesus. Encourage them to be like Jesus and talk to those people. Tell them they should not be surprised if the people they talk to are interested in learning more about Jesus! Close with a prayer for God to surprise the children this week.

## Teacher Tips

- For added effect, make a "well" prop from an oversized coffee can or box. Cover with brown paper and decorate to look like stones. Tell the story sitting beside the well.
- Noisemakers and horns should be available in bulk through your local party store.
- If your space does not permit the use of noisemakers, have the children make a "silent cheer" by lifting and waving their hands each time you say "surprise."

**SURPRISE!**

**SURPRISE!**

C



R



A



F



T



# The Samaritan Woman

## Telling Times

The children will review this week's lesson as they think of some good times to tell others about Jesus.

### Materials

For each child:

- 1 piece of construction paper, 9" x 12"
- 1 brass fastener
- crayon or markers
- glue stick

For the teacher:

- scissors
- invisible tape
- hole punch

Reproducible Pages:

- Page B, 1 copy for each child

### Preparation

1. For each child, cut the construction paper in half widthwise, as shown in Figure A. Then take one of the halves and cut in half lengthwise, as shown in Figure B.
2. Cut off one half-inch strip from each of the smaller pieces, as shown in Figure C. Punch holes at the ends of these small strips, and trim the other ends to make points, as shown in Figure C.
3. For each child, cut out the watch faces and clasps from the copies of Reproducible Page B.
4. Make a sample craft to show the children.

### Instructions

1. Introduce today's activity: *In today's lesson, we are learning that Jesus loved to talk to people about God—anywhere, anytime. He loved everyone and he loved to tell them about God. In the Bible Story, Jesus spoke to a Samaritan woman. She was surprised that Jesus knew her so well. She was so excited about Jesus that she went and told the people in her town. In your craft today, you are going to make something to remind you that it is always a good time to tell people about Jesus.*

2. Show the children the craft you made. Explain that it is a watch that they can hang in their rooms to remind them that it is always time to tell people about Jesus. Show them how the hands move.
3. Distribute the construction paper, watch faces and clasps you prepared, glue sticks and crayons to the children. Have the children glue their watch faces to their large piece of construction paper, as shown in Figure D. Have them glue their clasps to one end of one of their longer pieces of construction paper, as shown in Figure E.
4. Have the children place and glue their watch faces between the two longer pieces, with the clasp on top, as shown in Figure F. Reinforce the back with invisible tape.
5. Distribute the two small strips and brass fasteners. Help the children place their fasteners through the holes, into the center of the watch face, and secure by opening the flaps. Punch or draw three holes in the bottom piece of construction paper and trim the ends, as shown in Figure G.
6. Have the children write their names on the backs of their watches and color them.

### Conclusion

Tell the children that there are many ways to help people know about Jesus. One way to do this is to tell people about Jesus. Ask the children to put the hands of their watch on two places that they can tell someone about Jesus this week. Close with a prayer for the children to want to tell people about Jesus.

### Teacher Tips

- To save time in class, hole punch and trim the bottom pieces of the watches (from Step 5) in advance.
- Think of additional ways to customize this watch to your world sector. Use stickers or words to represent countries where your church has mission teams.



C  
•  
R  
•  
A  
•  
F  
•  
T  
•  
•

# The Samaritan Woman

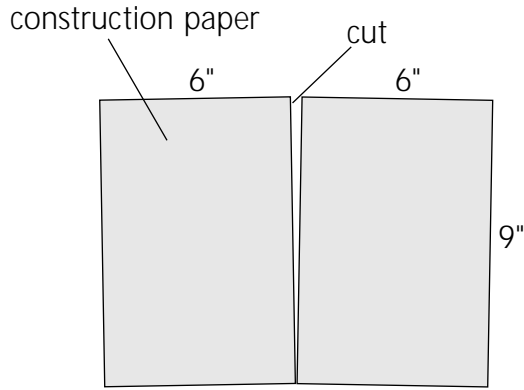

Figure A

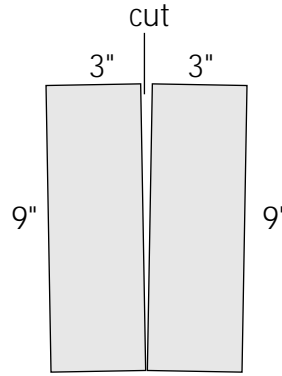

Figure B

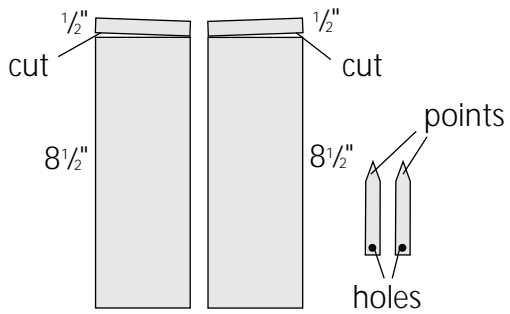

Figure C

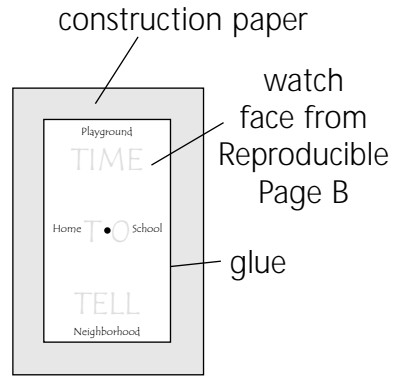

Figure D

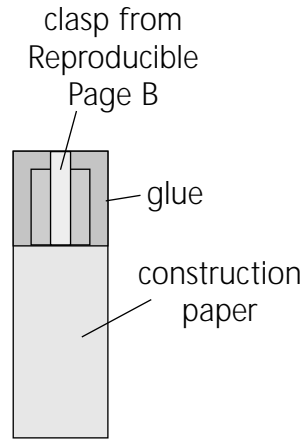

Figure E

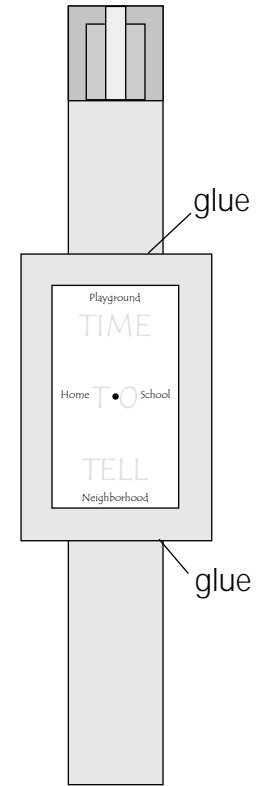

Figure F

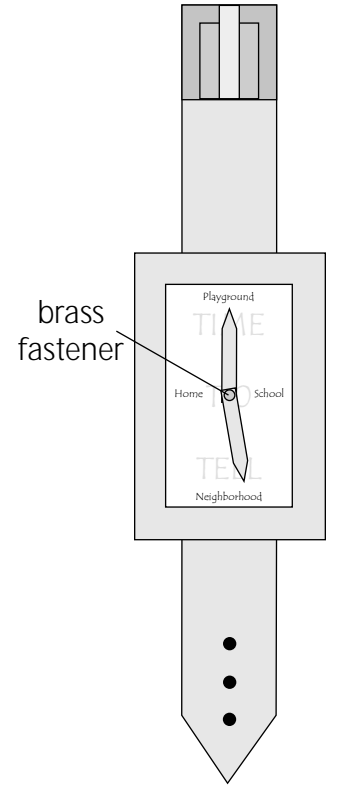

Figure G



# The Samaritan Woman

## Pass It On

The children will learn and memorize today's Scripture Memory Verse as they do this fun, hand-clapping activity.

### Scripture Memory Verse

Do not forget to do good and to share with others.  
*Hebrews 13:16*

### Materials

No additional materials needed.

### Preparation

1. Memorize today's Scripture Memory Verse.
2. Practice leading this activity several times until you are familiar with the steps and the hand motions.

### Instructions

1. Introduce today's activity: *In your lesson today, you are learning about a very special and surprising conversation that Jesus had with a Samaritan woman. You are learning that Jesus loved everyone he met—no matter where they came from. He wanted to share the good news about God with all people. Our Scripture Memory Verse today will remind us that God wants us to do good and share with others too.*
2. Show the children the Scripture Memory Verse on the back of this Lesson Card. Read it to them three times, pointing to the words while they listen. Ask them to say it with you three more times, each time pointing to the words for them. Ask each child to stand next to you and say the verse together with you. Ask for volunteers to say the verse alone.
3. Have the children sit in a circle with their legs crossed. Tell them that they are now going to say the verse as they clap their hands and slap their knees.

4. Demonstrate the motions by slapping your hands lightly on your knees two times, followed by clapping your hands together two times. This represents four "beats" that accompany the words in the verse. Tell the children that when you say the verse, you will slap your knees, but when they say the verse they will clap their hands. Using the following, lead them in saying the verse:

#### Teacher says:

*Do not* (slap slap)  
*for get* (slap slap)  
*to do* (slap slap)  
*good and* (slap slap)  
*to share* (slap slap)  
*with others* (slap slap)  
*He brews* (slap slap)  
*thir teen* (slap slap)  
*six teen* (slap slap)

#### Children respond:

Do not (clap clap)  
for get (clap clap)  
to do (clap clap)  
good and (clap clap)  
to share (clap clap)  
with others (clap clap)  
He brews (clap clap)  
thir teen (clap clap)  
six teen (clap clap)

5. Do this two more times all together.
6. Next, have the children say it together with you, without repeating.
7. Finally, have the children go around the circle saying the entire scripture while slapping their knees and clapping their hands.
8. Ask the children for volunteers to say the verse alone or with a partner.

### Conclusion

Encourage the children to share today's Scripture Memory Verse with their families or to make up their own hand motions. Close with a prayer thanking God for the Bible.

### Teacher Tips

- Take the time to practice enough that you don't have to refer to the Lesson Card.

# The Samaritan Woman

SCR  
IPT  
URE  
MEM  
ORY

Do not forget to  
do good and to  
share with others.

Hebrews 13:16





# The Samaritan Woman

Jesus with People  
Lesson 4

Lesson at  
a Glance supplement

## Lesson Objectives

- The children will tell the story of Jesus and the Samaritan woman.
- The children will identify the world sector for their church and mission.
- The children will tell one way they can help others know about Jesus.

## Lesson Text

John 4:1-42

## Scripture Memory Verse

Do not forget to do good and to share with others.

*Hebrews 13:16*

## Lesson Plan

Greeting and Registration

Preclass Activity: Friendly Reminders

Welcome and Singing

Centers:

Life Application: Missionary CARE Package

Game: Mission Possible

Bible Skills: Journey Through John

NOTE: Allow time for a snack.

NOTE: See "Special Note to Lead Teachers" on the Core Lesson at a Glance Page.

1st and 2nd Grades



pre  
class

**A  
C  
T  
I  
V  
I  
T  
Y**

## Friendly Reminders

The children will review the Bible Story as they make two special reminders for telling people about God.

### Materials

*For each child:*

- 1 piece of construction paper, 9" x 12"
- crayons
- scissors
- glue stick
- 1 pipe cleaner

*For the teacher:*

- hole punch

*Reproducible Pages:*

- Page C, 1 copy for each child

### Preparation

Make a sample of this activity to show the children.

## Instructions

1. Greet the children as they arrive. Remind them that their lesson this week was about Jesus and how he loved the Samaritan woman even though she was very different from him. Tell the children that they are going to make two things to help remind them of this week's Bible Story and to remind them to tell people about God wherever they go. Show the children the samples you prepared.
2. Distribute the copies of Reproducible Page C, crayons, construction paper and glue sticks. Have the children color the "Tell-A-Card" and the "Tell-A-Phone" and then help them glue their pages to their pieces of construction paper. Make sure they write their names in the spaces provided.

3. Distribute the scissors. Have the children cut out their cards and phones.
4. Circulate among the children to punch a hole in the telephone, on the "x." Distribute the pipe cleaners and help the children loop them through the hole and tie it. Show the children how to attach their phones to a belt loop or bag handle by twisting the pipe cleaner through.

## Teacher Tips

- Have adult assistants available to help the children and to share the things that help them remember to share their faith.

LIFE  
A  
P  
P  
L  
I  
C  
A  
T  
I  
O  
N**Missionary CARE Package**

The children will review this week's Bible Story as they think of ways that they can help with the missions in their world sector.

**Materials**

For each child:

- pencil
- crayons or markers
- stickers

For the teacher:

- large manila envelope
- large writing surface

Reproducible Pages:

- Page D, 1 copy for each child

**Preparation**

1. Obtain the name and address of the church and Children's Ministry Leaders who will receive the letters written by the children, as well as the following information about the church: pictures, bulletins, e-mails, good news, maps of the area, etc.
2. Cut out the Supply Lists and Form Letters from the copies of Reproducible Page D, and obtain the membership information needed to complete the letters.

NOTE: See the note to Lead Teachers on the Core Lesson at a Glance Page.

**Reviewing the Bible Story**

Open your Bible to John 4. *In this week's Bible Story, you learned that Jesus met a Samaritan woman at Jacob's Well. The woman was surprised that Jesus spoke to her. The disciples were surprised too! After she realized that Jesus was from God, she went and told the people of her town and they came to meet Jesus for themselves. Jesus loves everyone and he wants us to love everyone too.*

**Life Application**

*We want to be like Jesus. We want to tell everyone about God's love. That is why some disciples move to faraway places to teach people about God. A person who teaches other people about Jesus is called a missionary. You can be a missionary right here! Some*

*missionaries who move far away have to give up a lot of things. Some missionaries live in places where there is no television, no computers, even no running water. Missionaries understand that telling people about Jesus is the most important thing in the world—even more important than having a nice house or a television.*

Tell the children about the mission work in your world sector and about the church who will receive the CARE Package you are preparing. If possible, invite a former missionary to come and tell the children about mission work.

As a group, talk about the kinds of things that the children can collect to send in their CARE Package to support their mission work. Ideas may include: money; Bibles; medical supplies; clothes or toys; pictures of their friends in the local church, etc. Let the children know what the specific needs of the church are, based on your contact with the church. Encourage the children that one of the best things they can always do is to pray for the mission teams. Write their ideas on the large writing surface.

**The Package and Letters**

Distribute the Supply Lists and Form Letters you prepared and pencils. Decide what items will go into the CARE Package. Help the children write them down on their supply lists and take it home to their parents. Write a date for items to be collected.

Fill out the Form Letters together. Write and read the date and membership information on the large writing surface for the children to copy. Have the children work with partners. Distribute the stickers so they can decorate the letters with them. Make sure the children sign their letters and you put them in the envelope.

Tell the children you know that the mission church will be so excited to receive these letters and gifts. Encourage them to pray for their friends on the mission. Close with a prayer asking God to bless the CARE Package they are going to send.

**Teacher Tips**

- Take a picture of the children to include with the letters. Speak to each parent about the CARE Package.
- If time does not permit the children to finish the letters, ask them to return the finished letter with their supplies.



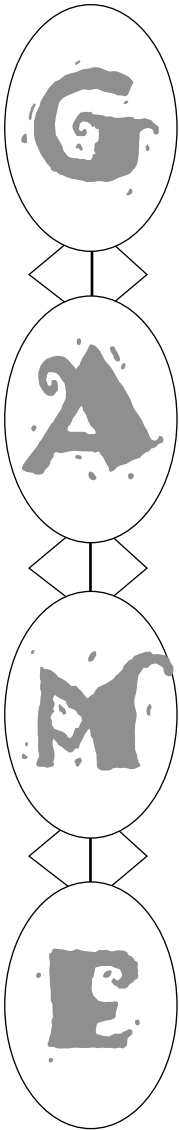

## Mission Possible

The children will learn about world missions and think of ways they can participate.

### Materials

For each child:

- 1 penny

For the teacher:

- 2 dice
- 2 pieces of paper
- 2 pencils

Reproducible Pages:

- Page E, 2 copies for the teacher

### Preparation

Practice playing this game at home.

### Instructions

1. Introduce today's activity: *In this week's lesson, we are talking and learning about world missions. The Bible Story about Jesus and the Samaritan woman showed us that Jesus loved everyone and wanted everyone to learn about God. Today, God wants us to tell people about Jesus too. He wants everyone to hear about Jesus. In order to do this, some people will have to go to far away places. People who tell others about Jesus are called missionaries. It takes a lot of prayer and hard work and money to start a church. In our game today, you will think about many of the things that have to happen to start a church.*
2. Divide the children in two teams. Give each team a copy of Reproducible Page E, a penny, a die, and paper and a pencil to keep score. Assign one child from each team to keep score.
3. Tell each team to place their pennies on the "START" space. Explain that these are their game pieces. The object of the game is to send as many missionaries and plant as many churches as possible. When a team has collected ten points, they can send off one missionary. After a team has sent ten missionaries, they have planted a church. Keep track of each team's progress as they add their points.

4. Choose a team to go first. Have them roll the die and move the same number of spaces. As they land on a space, they must read what it says aloud and then receive the designated points.
5. If they land on a "Mission Moment" space, read them one of the statements written on the back of this Lesson Card. The team receives two points for landing on the space. Ask the team: *What would God want you to do with this Mission Moment?* If the team answers appropriately, give them the points indicated. If not, offer an appropriate suggestion. For example, if the miracle is "School is cancelled!" answers could include: take extra time to pray for my friends; write a letter to a mission church. It is not wrong for a child to want to spend time with friends or watch television on a day off. The purpose of this activity is to help the children think of ways they could use their time to do something for missions.
6. Have the children keep count of the number of points they receive on their paper. The next team rolls the die and proceeds in the same way. When a team has earned ten points, they get credit for sending off one missionary. With each missionary sent off, a team earns two bonus points.
7. Play continues until time is up. At the end of the game, total the scores. Tell the teams how they did. Both teams are winners if they succeeded in sending out missionaries.

### Conclusion

*It was hard work for Jesus to tell people about God. At times, he was tired and hungry. But he always shared his faith. Jesus never let anything stop him. Today, it is still hard work to tell everyone about Jesus—but it is worth it! Planting churches is not a game, it is something God really wants us to do. Close with a prayer asking God to help us all be like Jesus and help everyone to learn about God.*

### Teacher Tips

- Mount the game boards on construction paper to make them more durable.
- The purpose of assigning a number value to each event is to teach the children that everything they do "counts" to God.



# The Samaritan Woman

## Mission Possible

### Mission Moments

Teacher's Note: Each Mission Moment can be read more than once.

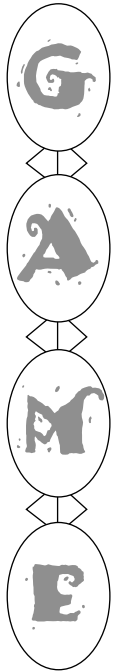

•Your  
nextdoor  
neighbor  
gives you a  
huge box of  
baby clothes.  
(5)

•Your father gets a raise!  
(5)

•You win \$100  
in a contest.  
(5)

•School is canceled!  
(5)

•You  
find a \$10  
dollar bill on the  
street. (5)

•Your mother wins free airplane  
tickets to anywhere in the world.  
(5)

•Your friend at  
school speaks the  
same language as  
your friends in the  
mission church.  
(5)



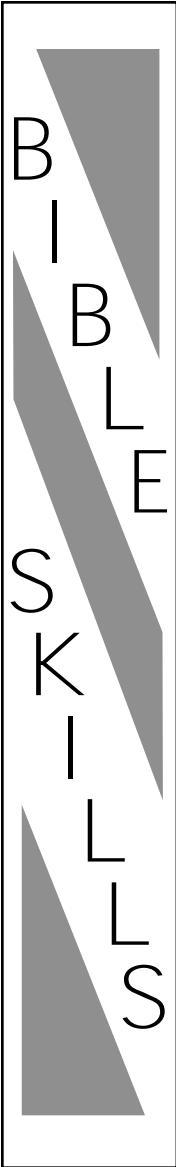

## Journey Through John

The children will explore the book of John and meet some of the people that Jesus helped.

### Materials

For each child:

- pencil

For the teacher:

- large writing surface

Reproducible Pages:

- Page F, 1 copy for each child

### Preparation

1. On the large writing surface, write a larger version of the chart that appears in the back of this Lesson Card. Fill in the left side with numbers. Leave the right side empty.
2. Complete the activity on your copy of Reproducible Page F.
3. Practice leading this activity with emphasis and enthusiasm.

NOTE: Have extra Bibles on hand for children who forget.

### Instructions

1. Introduce today's activity: *In this week's Bible Story, you learned about Jesus and the Samaritan woman. Jesus surprised the woman because he knew so much about her. Jesus knows everything about all of us! Jesus told the woman how she could be happy by loving and obeying God. She was so excited that she went and told the people in her town. They came out to meet Jesus and hear him teach about God.*

*This week's Bible Story comes from the New Testament gospel of John. Who remembers the names of all four gospels? (Take responses.) Matthew, Mark, Luke and John. In the gospel of John, you can learn about many people that Jesus talked to about God. In our activity today, you are going to meet six people that were with Jesus. Some of these are people you have already met.*

2. Distribute the copies of Reproducible Page F and the pencils. Have the children find a partner or small group of three to work with. Tell them to look at the large writing surface you prepared.

3. Tell the children to find the New Testament book of John in their Bibles. Offer help to new or visiting children. Make sure that all the children have their Bibles open to John 1.
4. Tell the children to look at the chart on their page and find the number one in the first row. Tell the children that the one stands for John chapter 1. Now tell the children that they are going to meet someone in John chapter 1.
5. Have the children find John 1:28. Read it to the children. Tell them that it is talking about John the Baptist. Explain that John came to tell the people that Jesus was coming. Write "John the Baptist" in the space provided on the large writing surface. Tell the children to trace over the words "John the Baptist" on their pages.
6. Have the children find John 2:1-2. Read it to them. Tell them that in this chapter, Jesus helps his mother solve a problem for some of her friends who were getting married. Jesus was always helping people. Write "Family and Friends" in the space provided. Have the children write it in the correct space on their pages.
7. Have the children find John 3:1-2. Read it to them. Tell them that in this chapter, Jesus teaches a man named Nicodemus. Have the children say "Nicodemus" with you. Explain that Nicodemus wanted to learn more about God and how to go to heaven. Jesus spent a whole evening with him telling him about God. Later on, Nicodemus became a follower of Jesus. Write "Nicodemus" in the space provided. Have the children write it in the space on their pages.
8. Have the children find John 4:7. Read it to them. Tell them that this is the same woman they learned about this week in their Bible Story. Ask them what they remember from the story. Remind them that Jesus was never too tired or scared or hungry to tell people about God. Write "Woman at the Well" in the space provided. Have the children write it in the space on their pages.
9. Have the children find John 5:1-3. Read it to them. Tell them that Jesus went to a place where there were many sick people. There was one man who had been there for thirty-eight years! Jesus healed him and then he told him not to sin anymore. Jesus wanted to help people feel better when they were sick and when they were sad too. Write "Sick Man" in the space provided. Have the children write it in the space on their pages.
10. Tell the children that the gospels are full of stories about people



# The Samaritan Woman



that Jesus helped and healed and told about God. Jesus was always doing good and sharing with people—just like their Scripture Memory Verse says.

- Mark the passages in your Bible in advance for easy reference.
- Let the children see your personal appreciation and enthusiasm for John’s gospel.

## Conclusion

Encourage the children to share their pages with their parents. Suggest that they do a family devotional about one of the people they learned about, or have their parents or older brothers or sisters help them read about them on their own. Close with a prayer for the children to love to read their Bibles.

## Teacher Tips

Chapter	People With Jesus
1	John the Baptist
2	Family and Friends
3	Nicodemus
4	Woman at the well
5	Sick Man



**Core/Preclass**  
1 copy for each child

R  
E  
P  
R  
O  
D  
U  
C  
I  
B  
L  
E  
  
P  
A  
G  
E  
  
A



---

---

---



Core/Craft  
1 copy for each child

R  
E  
P  
R  
O  
D  
U  
C  
I  
B  
L  
E  
P  
A  
G  
E  
B

Playground

TIME

Home T • O School

TELL

Neighborhood

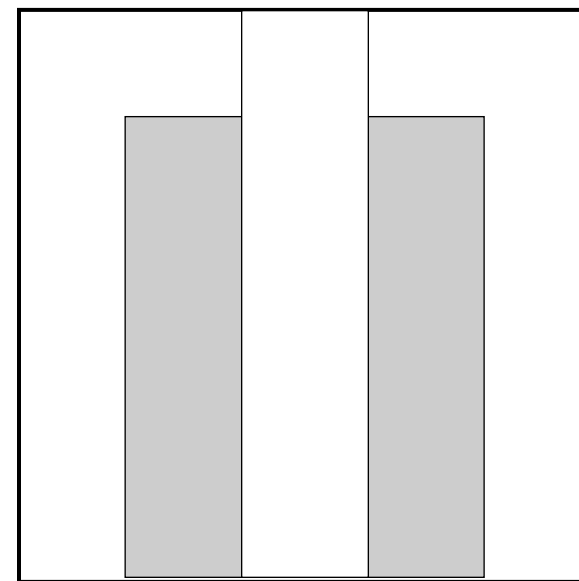



Supplement/Preclass

1 copy for each child

R  
E  
P  
R  
O  
D  
U  
C  
I  
B  
L  
E  
P  
A  
G  
E  
C

### Tell-A-Card

This card belongs to \_\_\_\_\_.

A friendly reminder to  
tell a friend  
about Jesus.

Do not forget to do good and to share with others.  
Hebrews 13:16

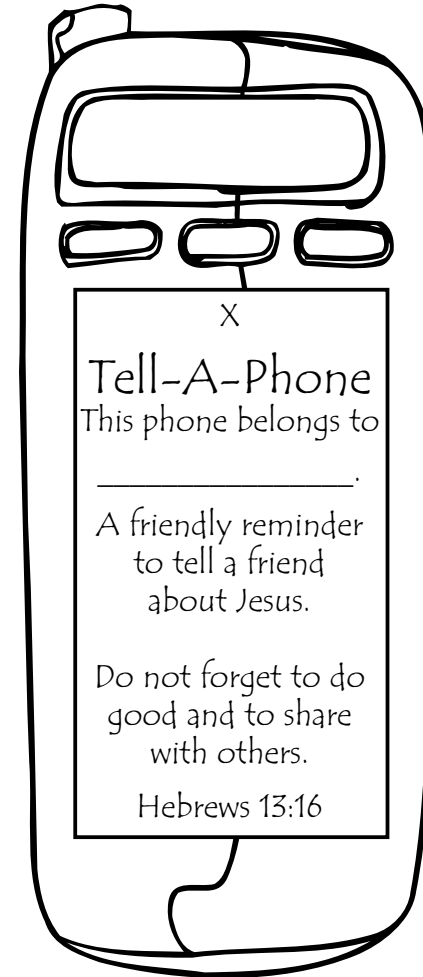

# Missionary CARE Package

## Supply List of Items to Collect

Date: \_\_\_\_\_

Dear Parents,

Please have your child bring in the following items to class on

\_\_\_\_\_.

1. \_\_\_\_\_
2. \_\_\_\_\_
3. \_\_\_\_\_
4. \_\_\_\_\_
5. \_\_\_\_\_

Thank you,

Your Child's Teachers

Date: \_\_\_\_\_

Dear \_\_\_\_\_,

My name is \_\_\_\_\_. I live in

\_\_\_\_\_.

I am \_\_\_\_\_ years old. I am in \_\_\_\_\_ grade.

The name of my church is \_\_\_\_\_

\_\_\_\_\_.

We have \_\_\_\_\_ people in our church and \_\_\_\_\_ children. There are \_\_\_\_\_ children in my class.

Today, we learned about missionaries. I want you to know that I care about you and would like to be your friend. My class has prepared some things that we hope will encourage you.

Please write back and let us know about your church and how you tell other people about Jesus.

Your friend,

\_\_\_\_\_



**Supplement/Game**  
2 copies for the teacher

<b>START</b>	God Loves You! ②	Invite your whole soccer team to church ⑤	Pray for a missionary ②	Read your Bible ②	Write a letter to the mission church ③	Give your allowance for missions ③	Mission Moment ②
	Pray for missions ②	Bring a friend to church ③					Tell your whole class about the mission church ⑤
	Read your Bible ②	Mission Moment ②					
	Raise money for missions ③	Pray for church leaders ②					Invite your neighbor to church ③
	Pray for your teacher ④	Your teacher comes to church ④	Pray for church leaders ②	Raise money for missions ③	Pray for church leaders ②	Read your Bible ②	Tell your whole class about the mission church ⑤



# Journey Through John

Chapter	People With Jesus
1	John the Baptist
2	Family and Friends
3	Nicodemus
4	Woman at the Well
5	Sick Man

R  
E  
P  
R  
O  
D  
U  
C  
I  
B  
L  
E  
P  
A  
G  
E  
F

PAGE

