

Farm Animals

Lesson Objectives

- The children will identify domesticated animals including farm animals and pets.
- The children will state that God made animals.
- The children will thank God for making animals.

Bible Story Text

Genesis 1:24-25

Bible Truth

God made animals.
(Genesis 1:24-25)

Lesson Plan

Greeting and Registration

Preclass Activity: Preclass Centers

Welcome and Singing

Centers:

Bible Story: The Farmer's House

Life Application: Animal Cube Game

Craft: Peek and See Barn

NOTE: Be sure to allow sufficient time for a snack.

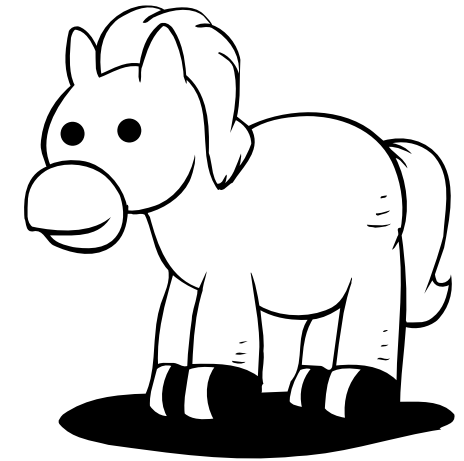

Farm Animals

Preclass Centers

As the children arrive, guide them to a preclass center. Have no more than six children at each center.

Materials

Use the materials previously selected for this unit's preclass centers.

Preparation

1. Be sure to check the condition of the materials selected for this unit's preclass centers prior to set up. Replace any broken toys, or puzzles with missing pieces as necessary.
2. Set up the centers before the children come into the classroom.
3. Assign a teacher to each center and have the teachers stay in those centers until the singing begins.

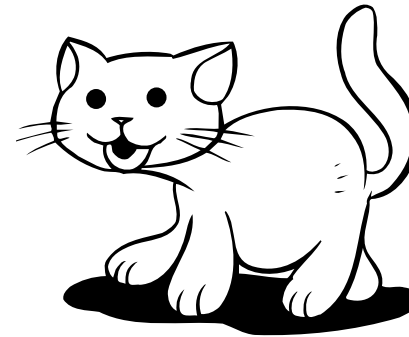
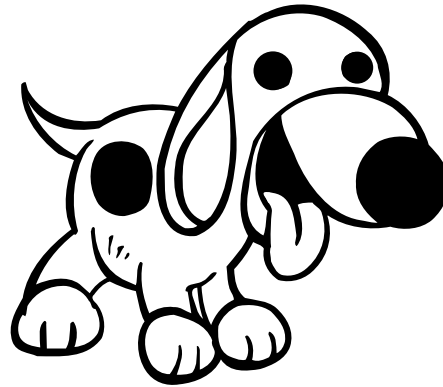

Instructions

Guide the play in each center reinforcing the unit theme.

Teacher Tips

- **IMPORTANT:** Do not allow any small toys in the classroom. First check all toys for size. You can obtain a "safety cylinder" from a pediatrician. Any object that can fit into the cylinder is too small and could cause a child to choke.
- Be involved in the group play and offer guidance as needed.
- Wear comfortable clothes suitable for sitting on the floor.
- Smile! Be childlike in heart and alert in mind.

Farm Animals

The Farmer's House

This Bible story emphasizes the variety of domesticated animals that God created.

Bible Story Text

Genesis 1:24-25

Materials

For the teacher:

- felt board with a black background
- felt board figures from Unit 7 Lesson 1, Bible Story
- tape

Preparation

1. Place tape on the back of each felt board figure.
2. Familiarize yourself with the story.

Instructions

Place the barn on the felt board as shown in Figure A. *God created everything. He made the day and the night, the sun and the moon, the clouds and the sky. God made the land and the water. He made the birds, the fish and animals. God made all the different animals.*

Place the cow on the felt board as shown in Figure B. *What kind of animal is this? Yes, this is a cow. What sounds do cows make? That's right. Let's all say this together, "Moo, Moo." A cow is a farm animal. Farm animals are animals that live on a farm. At night they sleep inside a barn.* Place the pig on the felt board as shown in Figure C. *What kind of animal is this? Yes, this is a pig. What sounds do pigs make? That's right. Let's all say this together, "Oink, Oink." A pig is a farm animal, too.* Place the chicken on the felt board as shown in Figure D. *What else did God make? That's right, a chicken. What sounds do chickens make? That's right. Let's all say this together, "Cluck, Cluck." A chicken is another kind of farm animal.*

God made all these animals. Let's sing a song about what God made on the sixth day. Sing line six of the "Creation Song" from the Unit 7 Song Sheet.

All of these animals live on a farm. Have you ever been to a farm? Have you ever seen any of these animals? Point to the figure of the barn. This is the barn. Sometimes animals sleep in the barn. The animals can also go inside the barn to keep warm when it is cold outside. Open the doors and place the chicken inside the barn,

and then close the barn doors. *God provides a barn to protect the animals.* Ask a child to place an animal inside the barn. *Mary, can you put the pig inside the barn?* Let each child take a turn placing an animal inside the barn.

Remove the barn and all the animal figures from the felt board. Place the farm house on the felt board as shown in Figure E. *On a farm where the animals live there is also a farmer. Point to the house. He lives in a farm house. The farmer takes care of all the animals. He loves animals. He even has some special animals called pets that live in his house. God created many different kinds of pets.*

Place the dog on the felt board as shown in Figure F. *What kind of animal is this? Yes, this is a dog. What sounds do dogs make? That's right. Let's all say this together, "Ruff, Ruff." A dog is a pet. God created dogs.* Place the cat on the felt board as shown in Figure G. *What kind of animal is this? Yes, this is a cat. What sounds do cats make? That's right. Let's all say this together, "Meow, Meow." A cat is a pet. God created cats, too.*

All of these animals live inside a house. Open the doors and place the cat inside the house, and then close the doors of the house. *God provides a house to protect the animals.* Ask a child to place a pet inside the house. *Grace, can you put the cat inside the house?* Let each child take a turn placing a pet inside the house.

NOTE: Save the felt board figures for Unit 7 Lesson 3, Bible Story.

Conclusion

Sing "God Made Animals" from the Unit 7 Song Sheet.

Who made all these animals? That's right! God did. Let's say the Bible Truth together, God made animals.

Let's thank God for making farm animals and pets. Let each child, who would like to, pray. Use the pictures on the felt board to prompt the children to thank God for specific animals.

NOTE: Save the felt board figures for Unit 7 Lesson 3, Bible Story.

Teacher Tips

If time permits, play a game of "Who's in the Barn?" Leave two animals on the board and put one inside the barn. Have the children guess which animal is inside the barn.



Farm Animals

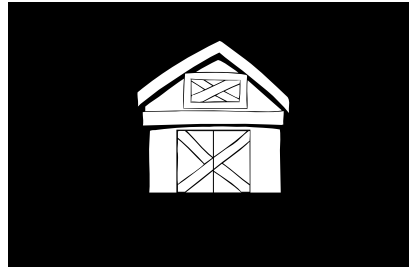

Figure A

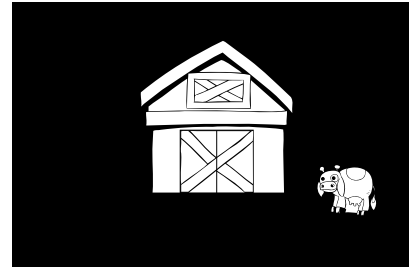

Figure B

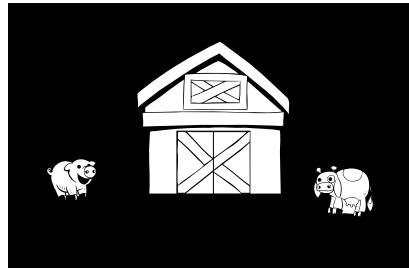

Figure C

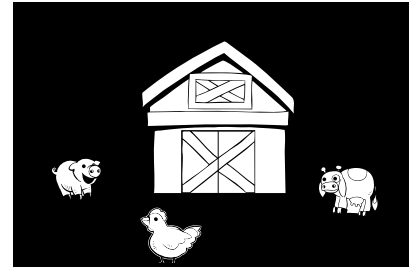

Figure D



Figure E



Figure F



Figure G

Farm Animals

Animal Cube Game

The children will play a game to help them learn the names of six domesticated animals that God created.

Bible Truth

God made animals.
(Genesis 1:24-25)

Materials

For the teacher:

- cube from Unit 7 Lesson 1, Life Application

Preparation

Familiarize yourself with the activity.

Instructions

1. Show the cube to the children. Point to each animal and let the children say the animal's name.
2. Show the children how to drop the cube from a standing position.
3. Choose a child to drop the cube. Ask what animal is pictured on the top of the cube. *Who made that animal? Yes, God did!*
4. After all of the children have had a turn, play the game again. This time have the children make the sound that corresponds to the animal pictured on the top of the cube.

Bible Truth Activity

Point to each animal on the cube and let the children name it.

God made the animals. Let's say it together, God made animals.

Conclusion

God created all of these wonderful animals. That makes me feel very happy! I like animals.

Let's thank God for animals. Thank you, God, for making animals.

Many people don't know that God made animals. Who can you tell what we learned in Bible class today?

Teacher Tips

Help any child who may have a hard time remembering the name of an animal or the sound it makes.

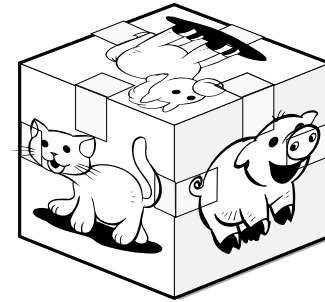

Farm Animals

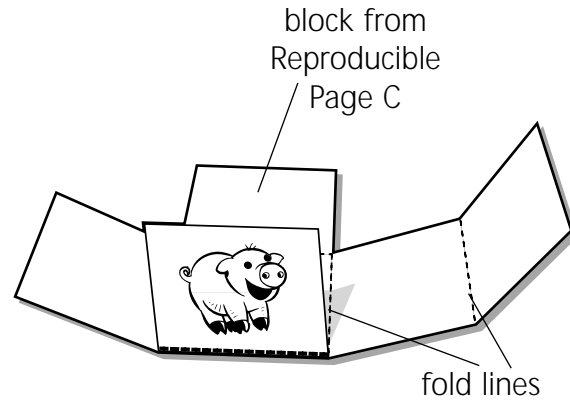

Figure A

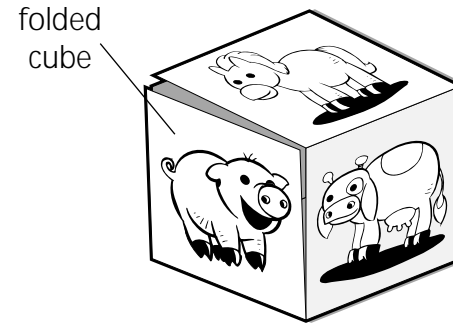

Figure B

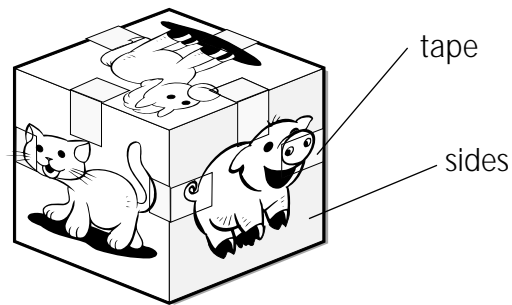

Figure C

Farm Animals

Peek and See Barn

This craft will show that God provides a barn as a home for farm animals.

Materials

For each child:

- 1 sheet of red construction paper
- 1 thin paper plate
- 1 brass fastener
- glue stick
- crayons
- envelope (optional)

For the teacher:

- black marker
- scissors

Reproducible Pages:

- Page A, 1 copy for the teacher
- Page B, 1 copy for each child

Preparation

1. Cut out the barn stencil from the copy of Reproducible Page A.
2. Trace and cut out a barn from red construction paper for each child.
3. Draw 2½" x 2½" barn doors as shown in Figure A.
4. Cut the doors along the top and center so that they open and shut.
5. Draw windows on the barn with a black marker. See Figure B.
6. Attach a paper plate to the back of each barn with a brass fastener. See Figure C.
7. Cut out the animal pictures from each copy of Reproducible Page B.
8. Make a model of the craft following the instructions.

Instructions

1. Give each child one of each animal picture.
2. Have the children color the animal pictures.
3. Have the children open the doors to their barns, and then glue one of their animals to their paper plates. See Figure D.
4. Help the child rotate the paper plate, and then glue on another animal. Have them continue this step until they have glued all four animals on their plates.

Conclusion

Have the children open the doors of their barns and turn the wheels. *Which animal do you see in the door of your barn, Patty? Yes, that is a cow. What does a cow say? Yes it says, "Moo, Moo." Who made the cow? Yes. God made the cow and all the animals.*

Teacher Tips

Place the four animal pictures in a separate envelope for each child prior to class.

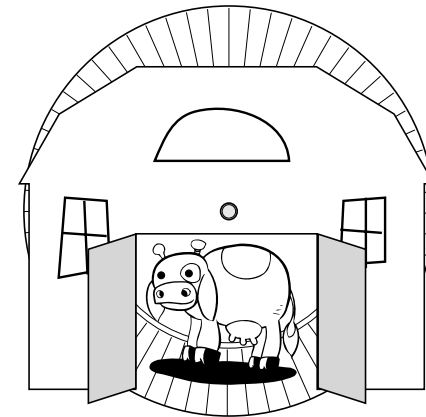

Farm Animals

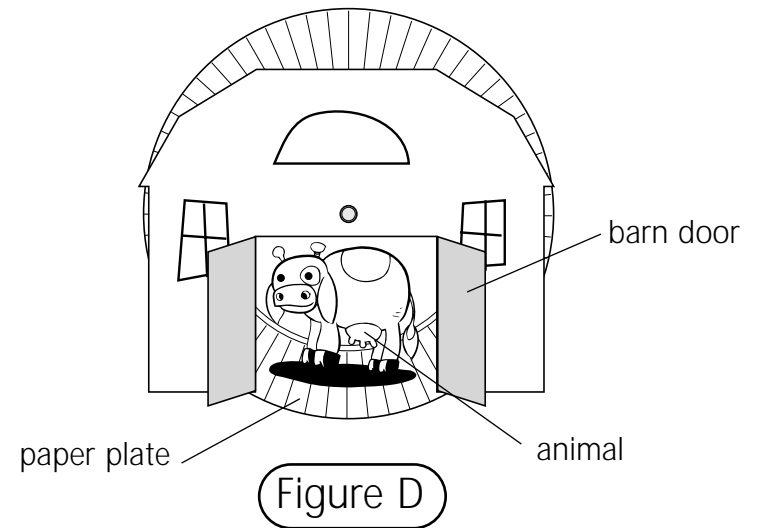
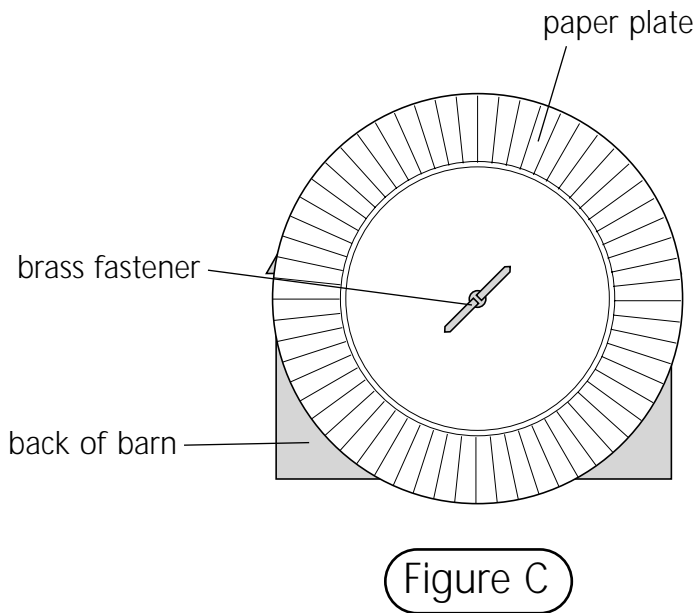
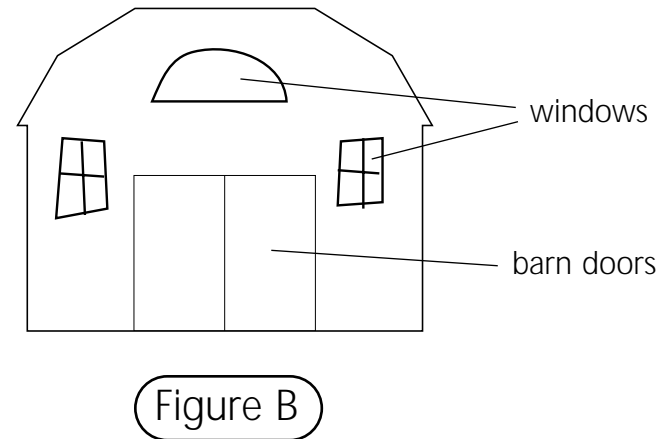
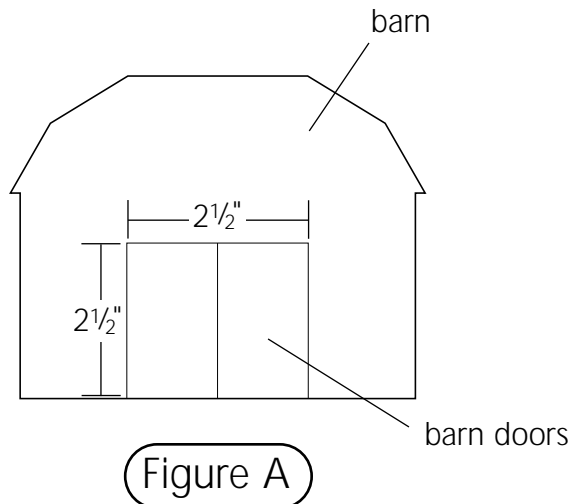



Farm Animals

Animals

Lesson 2

Lesson Objectives

- The children will identify domesticated animals including farm animals and pets.
- The children will state that God made animals.
- The children will thank God for making animals.

Bible Story Text

Genesis 1:24-25

Bible Truth

God made animals.
(Genesis 1:24-25)

Preclass Centers

As the children arrive, guide them to a pre-class center. Have no more than six children at each center.

Materials

Use the materials previously selected for this unit's preclass centers.

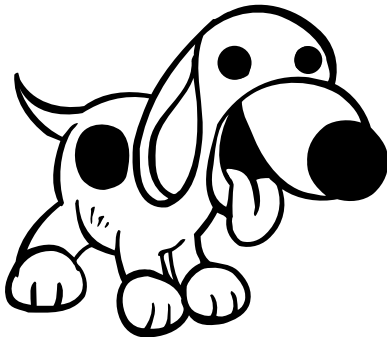

Preparation

1. Be sure to check the condition of the materials selected for this unit's preclass centers prior to set up. Replace any broken toys, or puzzles with missing pieces as necessary.
2. Set up the centers before the children come into the classroom.
3. Assign a teacher to each center and have the teachers stay in those centers until the singing begins.

Instructions

Guide the play in each center reinforcing the unit theme.

Lesson Plan

Greeting and Registration

Preclass Activity: Preclass Centers

Welcome and Singing

Centers:

Life Application: Animal Appetites

Bible Story: The Farmer's House

Craft: How Now Brown Cow

NOTE: Be sure to allow sufficient time for a snack.

Teacher Tips

- **IMPORTANT:** Do not allow any small toys in the classroom. First check all toys for size. You can obtain a "safety cylinder" from a pediatrician. Any object that can fit into the cylinder is too small and could cause a child to choke.
- Be involved in the group play and offer guidance as needed.
- Wear comfortable clothes suitable for sitting on the floor.
- Smile! Be childlike in heart and alert in mind.

Animal Appetites

The children will play a game in which they will learn the names of animals and what they eat.

Bible Truth

God made animals.
(Genesis 1:24-25)

Materials

For the teacher:

- animal and food cards from Unit 7 Lesson 1, Life Application

Preparation

Familiarize yourself with the activity.

Instructions

1. Show the children the cow card. *What is this animal? Yes, it is a cow. What kind of sound does a cow make? That's right, cows say, "Moo, Moo."* Let the children repeat the sound together. *What does the cow eat? Does he like to eat candy? No! Does he like to eat ice cream? No! Does he like to eat bananas? No! He likes to eat grass!* Show the children the grass card, and place it next to the cow card.
2. Show the children each of the animal cards. Asking questions, as shown in the example above, help them determine what each animal eats. Match the appropriate food card with each animal card.
3. For a class of mostly twos, play a card game as detailed below:
 - A. Place all of the animal cards face up on the floor or a table.
 - B. Place all of the food cards face up on the floor or a table.
 - C. Have the children take turns matching an animal card with the corresponding food card.



Farm Animals

4. For a class of mostly threes, play a card game as detailed below:
 - A. Place all the animal cards face down on the floor or a table in a group.
 - B. Place all the food cards face down on the floor or a table in another group.
 - C. Let each child take a turn flipping over one card from each group. Have the child determine if the animal card matches the food card. If the child has a match, have him identify the animal and what food it eats. After the child's turn have him flip the cards back so they are facing down again.
 - D. Have the next child take a turn.
 - E. Encourage the children after every attempt to match the cards.

NOTE: Save the animal and food cards to use during Unit 7 Lesson 4, Life Application.

Conclusion

God made all the animals and he takes very good care of them. He gives them everything that they need to live. He gives them food, and a place to sleep, such as a barn or a house. He takes care of the animals just like he takes care of us!

Let's thank God for making animals. Thank you, God, for making all of the animals.

Many of our friends do not know that God made the animals. Who are you going to tell about what we learned in Bible class today?

Teacher Tips

Ask the children who they told about last week's Bible class.

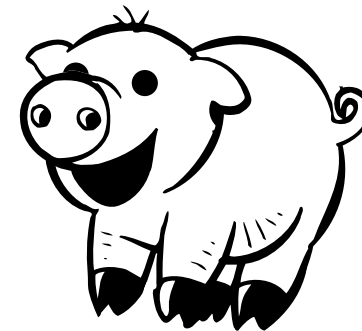

The Farmer's House

This Bible story emphasizes the variety of domesticated animals that God created.

Bible Story Text

Genesis 1:24-25

Materials

For the teacher:

- felt board with a black background
- felt board figures from Unit 7 Lesson 1, Bible Story
- tape

Preparation

1. Place tape on the back of each felt board figure.
2. Familiarize yourself with the story.

Instructions

Place the barn on the felt board as shown in Figure A. *God created everything. He made the day and the night, the sun and the moon, the clouds and the sky. God made the land and the water. He made the birds, the fish and animals. God made all the different animals.*

Place the cow on the felt board as shown in Figure B. *What kind of animal is this? Yes, this is a cow. What sounds do cows make? That's right. Let's all say this together, "Moo, Moo." A cow is a farm animal. Farm animals are animals that live on a farm. At night they sleep inside a barn.* Place the pig on the felt board as shown in Figure C. *What kind of animal is this? Yes, this is a pig. What sounds do pigs make? That's right. Let's all say this together, "Oink, Oink." A pig is a farm animal, too.* Place the chicken on the felt board as shown in Figure D. *What else did God make? That's right, a chicken. What sounds do chickens make? That's right. Let's all say this together, "Cluck, Cluck." A chicken is another kind of farm animal.*

God made all these animals. Let's sing a song about what God made on the sixth day. Sing line six of the "Creation Song" from the Unit 7 Song Sheet.

All of these animals live on a farm. Have you ever been to a farm? Have you ever seen any of these animals? Point to the figure of the barn. This is the barn. Sometimes animals sleep in the barn. The animals can also go inside the barn to keep warm when it is cold outside. Open the doors and place the chicken inside the barn,

Farm Animals

Animals Lesson 2

and then close the barn doors. *God provides a barn to protect the animals.* Ask a child to place an animal inside the barn. *Mary, can you put the pig inside the barn?* Let each child take a turn placing an animal inside the barn.

Remove the barn and all the animal figures from the felt board. Place the farm house on the felt board as shown in Figure E. *On a farm where the animals live there is also a farmer. Point to the house. He lives in a farm house. The farmer takes care of all the animals. He loves animals. He even has some special animals called pets that live in his house. God created many different kinds of pets.*

Place the dog on the felt board as shown in Figure F. *What kind of animal is this? Yes, this is a dog. What sounds do dogs make? That's right. Let's all say this together, "Ruff, Ruff." A dog is a pet. God created dogs.* Place the cat on the felt board as shown in Figure G. *What kind of animal is this? Yes, this is a cat. What sounds do cats make? That's right. Let's all say this together, "Meow, Meow." A cat is a pet. God created cats, too.*

All of these animals live inside a house. Open the doors and place the cat inside the house, and then close the doors of the house. *God provides a house to protect the animals.* Ask a child to place a pet inside the house. *Grace, can you put the cat inside the house?* Let each child take a turn placing a pet inside the house.

NOTE: Save the felt board figures for Unit 7 Lesson 3, Bible Story.

Conclusion

Sing "God Made Animals" from the Unit 7 Song Sheet.

Who made all these animals? That's right! God did. Let's say the Bible Truth together, God made animals.

Let's thank God for making farm animals and pets. Let each child, who would like to, pray. Use the pictures on the felt board to prompt the children to thank God for specific animals.

NOTE: Save the felt board figures for Unit 7 Lesson 3, Bible Story.

Teacher Tips

If time permits, play a game of "Who's in the Barn?" Leave two animals on the board and put one inside the barn. Have the children guess which animal is inside the barn.

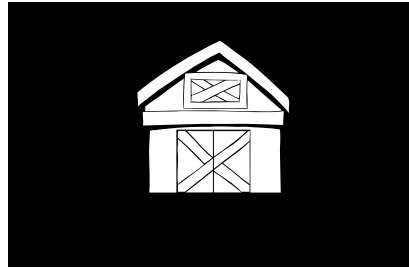

Figure A

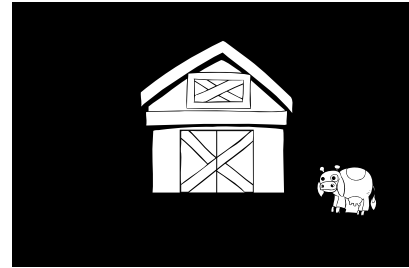

Figure B

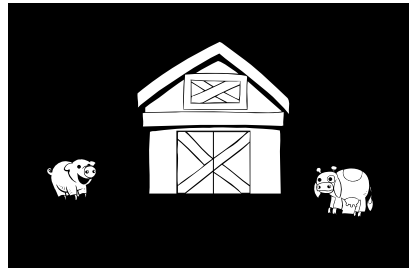

Figure C

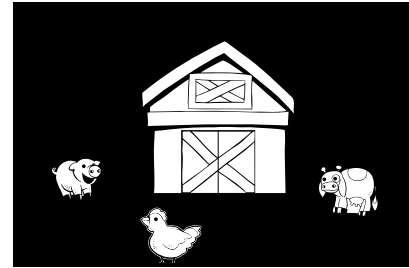

Figure D

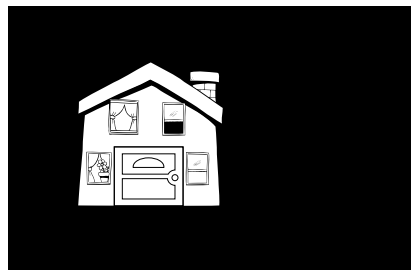

Figure E



Figure F

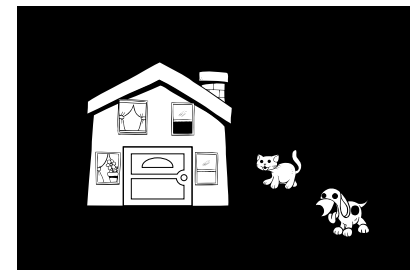

Figure G

C
r
a
f
t

How Now Brown Cow

The children will be reminded that God made farm animals.

Materials

For each child:

- 2 spring clip clothespins

For the teacher:

- black or brown poster board
- scissors
- black or brown yarn
- white, non-toxic paint
- 2 small sponges
- 2 paper plates
- plastic tablecloth
- single hole punch

Reproducible Pages:

- Page C, 1 copy for the teacher

Preparation

1. Cut out the cow stencil from the copy of Reproducible Page C.
2. Trace and cut out one cow for each child from the poster board.
3. Punch two holes, as shown in Figure A, on each of the cows as follows:
 - A. Punch one hole to make an "eye."
 - B. Punch another hole to be used to thread yarn through for a "tail."
4. Cut the yarn into 6" pieces. Cut two pieces for each child.
5. Make a model of the craft following the instructions.

Instructions

1. Prior to class, place the tablecloth on the work area to protect it against any paint spills.
2. Place the white paint onto the two paper plates. Place the plates onto the tablecloth making two paint stations.
3. Give each child a cow.
4. Help the children thread two pieces of yarn through the tail hole, and then tie the ends together making a tail. See Figure B.
5. Send two children to the two paint stations. Have them dip their sponges in the paint, and then onto their cows making white spots.
6. Allow the paint to dry.
7. Give each child two clothespins to clip on each cow making "legs." See Figure C.

Conclusion

Let the children gently play with their cows.

Who made the cows? Yes, God made the cows. Cows are farm animals. God made animals. Let's say that together, "God made animals."

Teacher Tips

- Plastic trays or place mats can be used in place of a tablecloth.
- If time allows, you can help the children draw a mouth and nose on the finished cow.

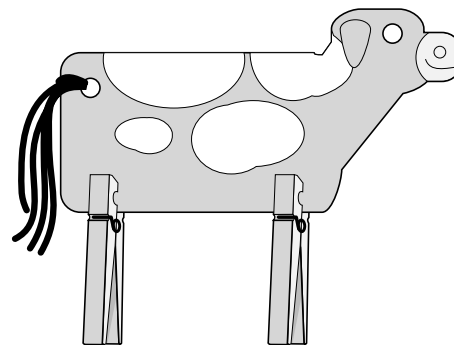

Craft

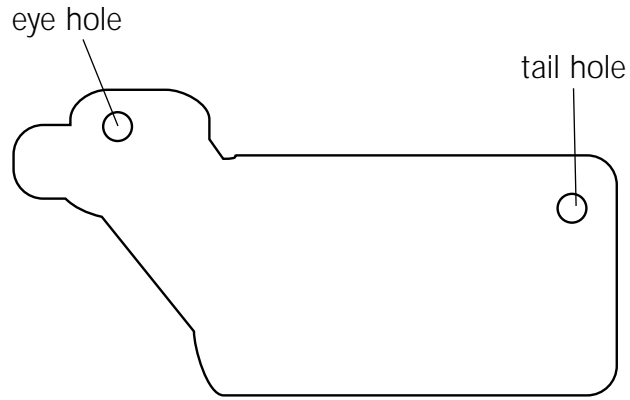

Figure A

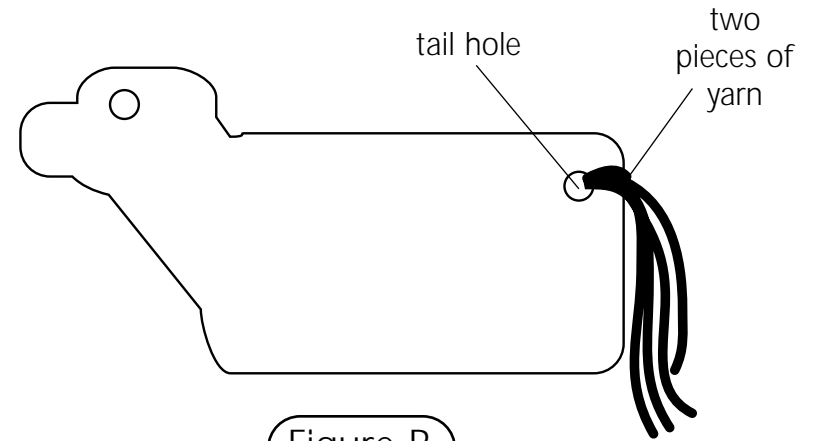

Figure B

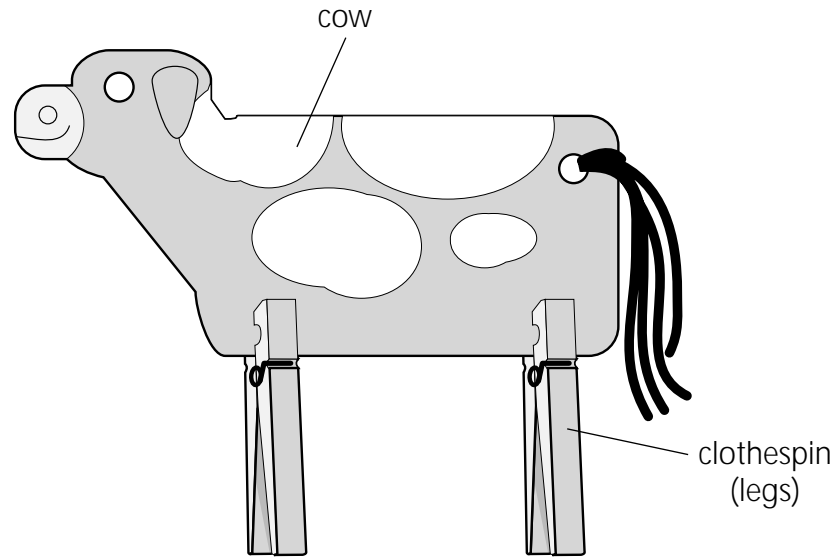

Figure C





R
e
p
r
o
d
u
c
i
b
l
e

Core/Craft
1 copy for the teacher

Animals
Lesson 2

barn stencil

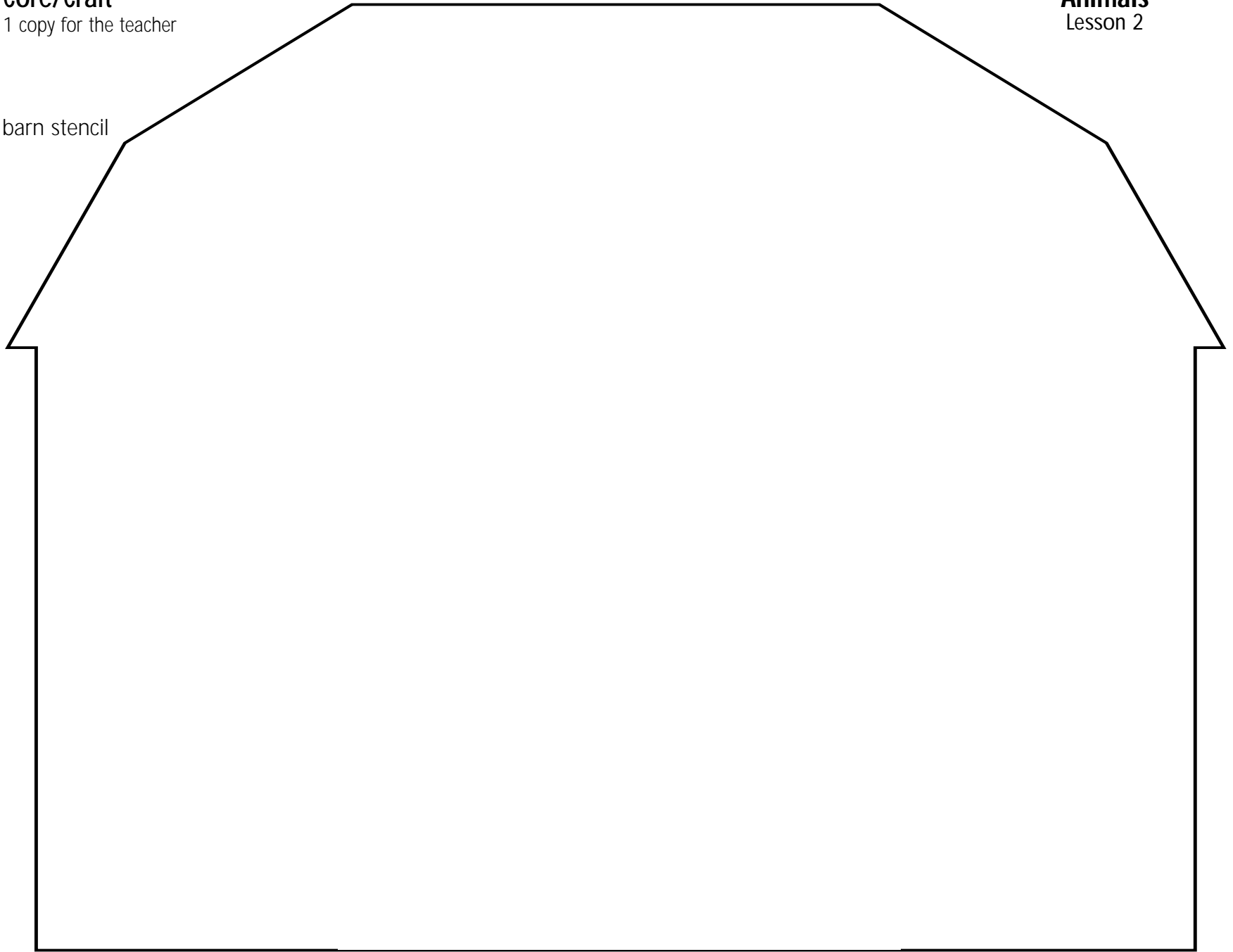



R
e
p
r
o
d
u
c
t
i
o
n
e

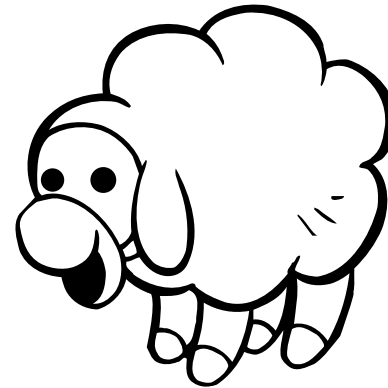
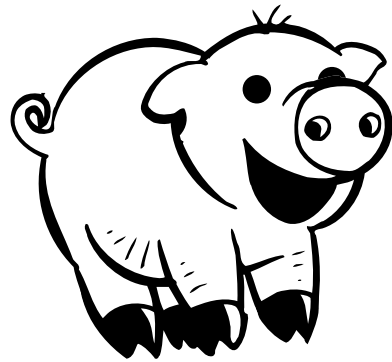
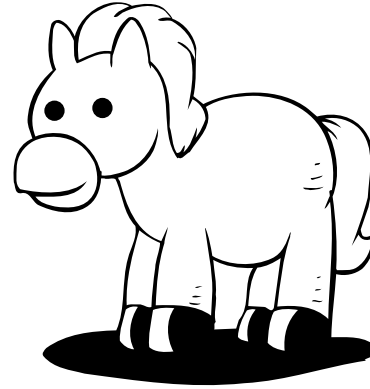
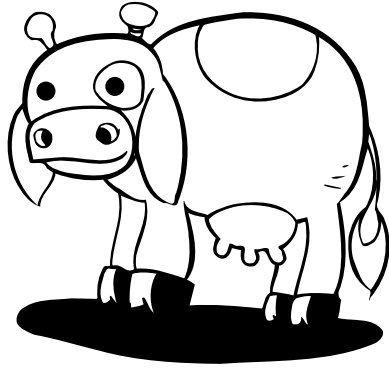

Animal Figures





R
e
p
r
o
d
u
c
i
b
l
e

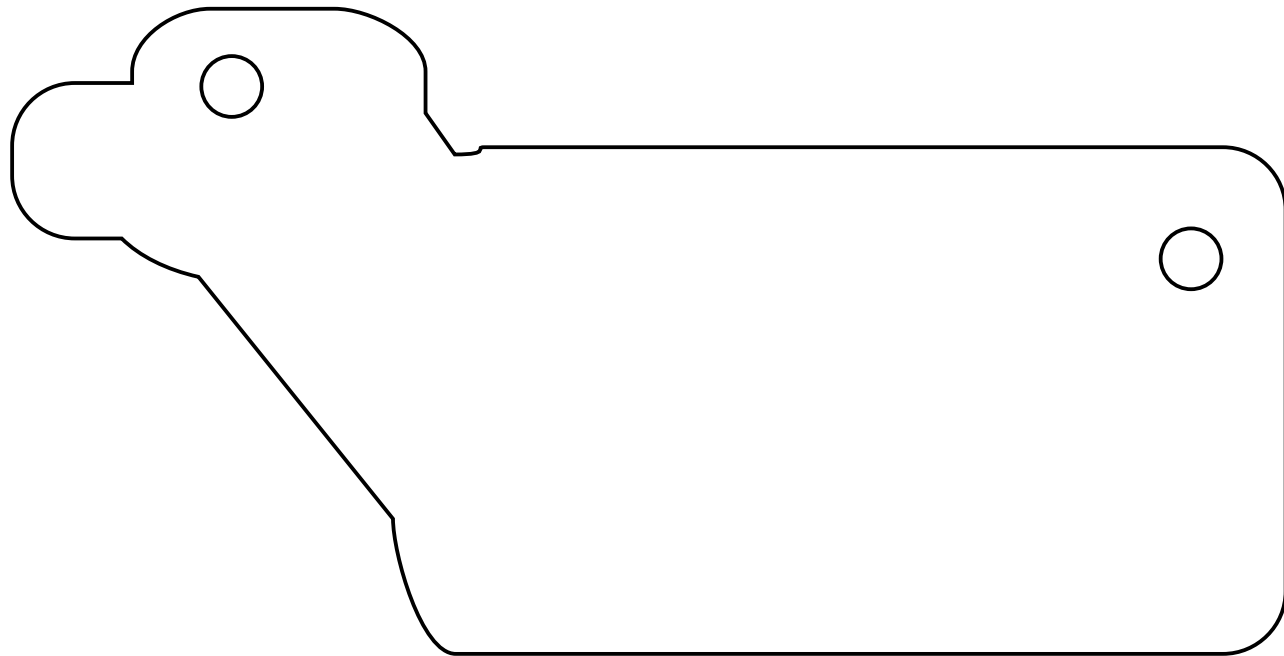

cow stencil

