

# Review

## Lesson Objectives

- The children will identify Jesus as a shepherd.
- The children will state that Jesus takes care of them by giving them families, homes, food and clothes.
- The children will thank Jesus for taking care of them.

## Bible Story Text

Ezekiel 34:11-16

## Bible Truth

"Love each other."  
(John 15:17)

## Lesson Plan

Greeting and Registration

Preclass Activity: Preclass Centers

Welcome and Singing

Centers:

Bible Story: Love Each Other

Life Application: The Lost Lamb

Craft: Sheep in the Pen

NOTE: Be sure to allow sufficient time for a snack.

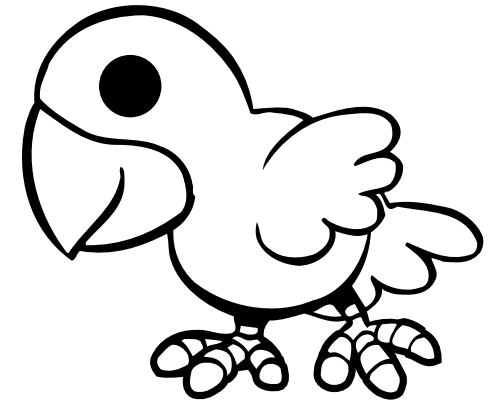

# Review

## Preclass Centers

As the children arrive, guide them to a preclass center. Have no more than six children at each center.

### Materials

Use the materials previously selected for this unit's preclass centers.

### Preparation

1. Be sure to check the condition of the materials selected for this unit's preclass centers prior to set up. Replace any broken toys, or puzzles with missing pieces as necessary.
2. Set up the centers before the children come into the classroom.
3. Assign a teacher to each center and have the teachers stay in those centers until the singing begins.

### Instructions

Guide the play in each center reinforcing the unit theme.

### Teacher Tips

- **IMPORTANT:** Do not allow any small toys in the classroom. First check all toys for size. You can obtain a "safety cylinder" from a pediatrician. Any object that can fit into the cylinder is too small and could cause a child to choke.
- Be involved in the group play and offer guidance as needed.
- Wear comfortable clothes suitable for sitting on the floor.
- Smile! Be childlike in heart and alert in mind.

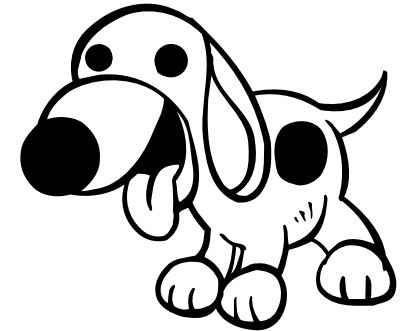
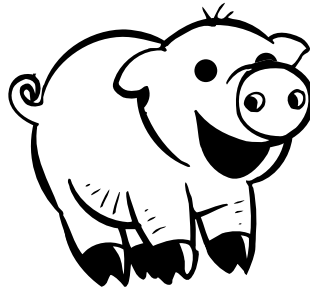
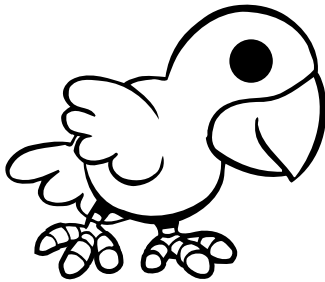

# Review

## Love Each Other

The children will be reminded that, just as Jesus looks for and takes care of them, they should also love each other.

### Bible Story Text

Ezekiel 34:11-16

### Materials

*For the teacher:*

- Bible
- 4 small stuffed animals or dolls including 1 lamb
- blanket to hide the lamb
- small bag of "pet" food
- food dish
- dish towel
- shoe box

### Preparation

1. Familiarize yourself with the Bible story and the song from the Unit 6 Song Sheet.
2. Just prior to class, set up your teaching space as follows:
  - A. Place some pet food in the food dish.
  - B. Place the food dish and the towel into the shoe box.
  - C. Hide the "lost" lamb stuffed animal under the blanket.
  - D. Arrange all the other stuffed animals around the blanket so the lamb is better hidden.

### Finding the Lamb

Sit with the children in a circle. Place the shoe box behind you. Place the Bible on your lap and open it. *The Bible says that Jesus takes care of us like a good shepherd takes care of his sheep. He looks for us, feeds us, takes care of our "boo-boos," and he gives us beds to sleep in. We can be good shepherds, too! I have a little lamb that is lost and I need your help to find it. Will you be good shepherds with me and help me find my lost lamb?*

*Look, here is an animal. Maybe he has seen my lost lamb.* Hold up one of the stuffed animals. Have the children wave and say, "Hello. We are good shepherds looking for our little lost sheep. Have you seen him?" Have the animal shake his head no. Have the children thank the animal.

*Look, here is another animal. Maybe he has seen my lost lamb.* Hold up a different stuffed animal. Have the children wave and say, "Hello. We are good shepherds looking for our little lost sheep. Have you seen him?" Have that animal shake his head no. Have the children thank the animal.

*Look, here is another animal. Maybe he has seen my lost lamb.* Hold up the last stuffed animal. Have the children wave and say, "Hello. We are good shepherds looking for our little lost sheep. Have you seen him?" Have that animal answer, "Yes, I have! Your little lost lamb was here looking for food and for a bed."

*He must be very close. Where do you think our little lost lamb could be? Do you think he might be asleep under this blanket?* Pick up the blanket to reveal the little lamb. Hug the lamb and let the children take turns hugging him as well. *Let's make a house with a bed for our lamb, and give him some food.*

Pick up the box behind you and place it in front of you. Let the children take turns pretending to feed the lamb. Talk about how Jesus makes sure that we have homes, beds and food. *Because Jesus is a good shepherd to us, we should also love each other.*

### Conclusion

*The Bible tells us that Jesus is our Good Shepherd. He looks for us and finds us, just as we found the lost lamb. Jesus also gives us a home, a bed and food to eat. We can be good shepherds, too!*

Sing "Where is My Lamb?" from the Unit 6 Song Sheet. Repeat the song each time using a different child's name.



# Review

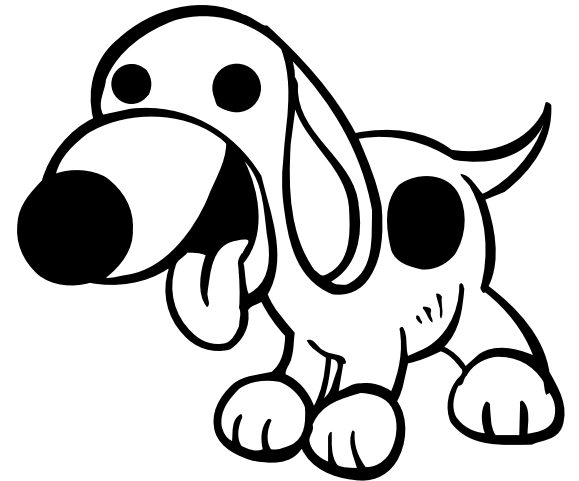
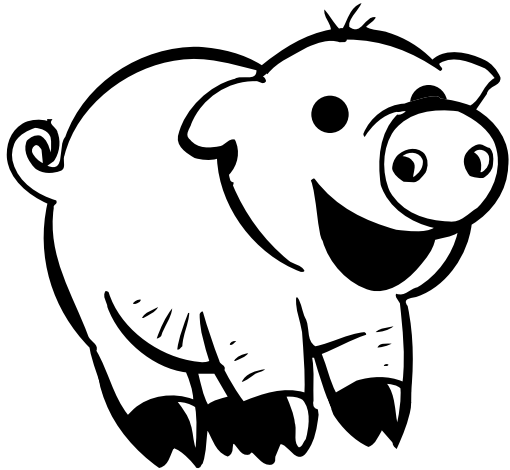
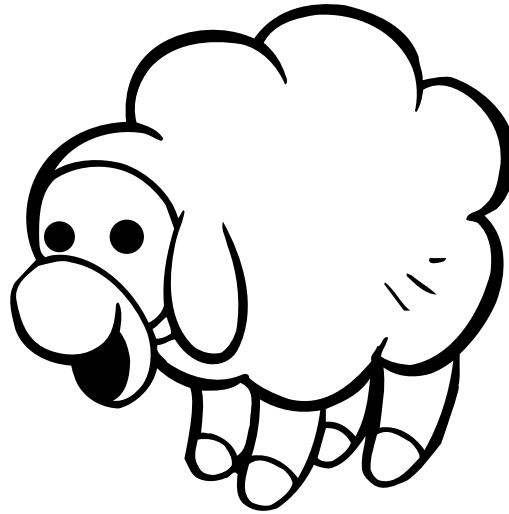
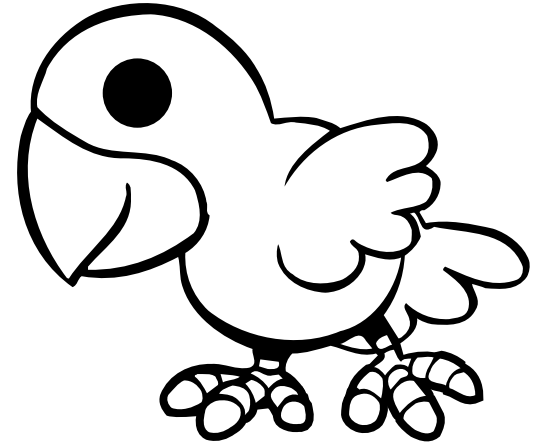
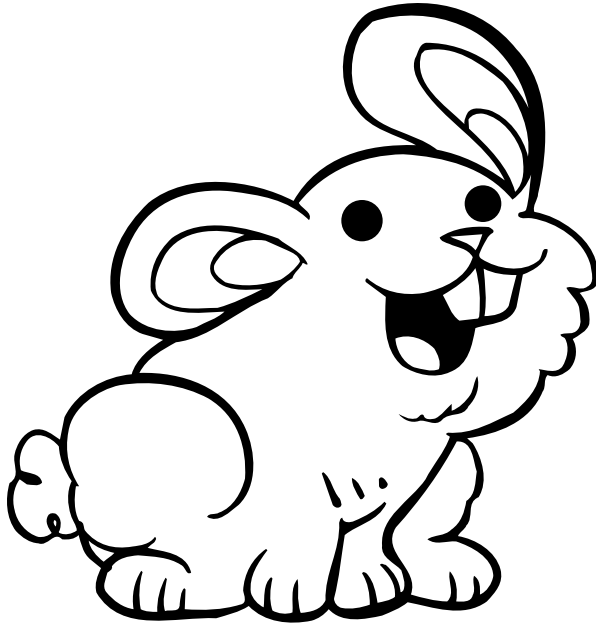

# Review

## The Lost Lamb

The children will learn how Jesus takes care of them as they care for a little lost lamb.

### Bible Truth

"Love each other."  
(John 15:17)

### Materials

*For the teacher:*

- black marker
- 1 large cotton ball
- tape
- 3 opaque plastic cups

### Preparation

1. Draw two black eyes on the cotton ball to make a simple lamb.
2. Make a loop from a piece of tape with the sticky side facing out.
3. Attach the lamb to the inside bottom of one of the cups.

### Instructions

Hold up the cup which has the lamb inside, *Guess what is inside this cup? It's a little lamb!* Show the children the lamb inside the cup. *The lamb's name is Baaaby.*

Take the cup and place it upside down in front of you. Place the other cups upside down near it. Move the cups around so that the cup with the lamb is "lost" among the other cups.

Say to the children: *The shepherd who takes care of Baaaby is looking for him. He's calling for him. Let's call for him, too.* Have the children call with you. *Baaaby, where are you? Baaaby, where are you?*

*It looks like Baaaby is lost! I'll be a good shepherd and find him. Is he in this cup?* Put your finger on an empty cup and ask, *Is Baaaby in here?* Pick up the empty cup and look underneath. Show the cup to the children and act disappointed. *No, Baaaby is not in here.* Put your finger on a second empty cup. *Is he in here?* Pick it up and say, *No, Baaaby is not in here, either.* Pick up the last cup and act surprised and delighted to see the lamb inside. *HERE is our lost Baaaby!*

Put the cups upside down and move them around again. Let the children take turns being a shepherd and finding the lost lamb in the cups. Allow each child to turn over the cups until he finds the one with the lamb. Encourage the child by saying, *You are a good shepherd. You found the lost lamb!*

### Conclusion

*Jesus is a good shepherd. He takes care of us and he loves us this much.* Open your arms wide and have the children do the same. *We should also love each other this much.*

*Many people don't know that Jesus loves them. Who can you tell this good news to?*

*Let's thank God that he and Jesus love us. Dear God, thank you that you love and take good care of us. Thank you that Jesus is the Good Shepherd that watches over us. Amen.*

### Teacher Tips

Be sure that the lamb remains in the cup while you play.

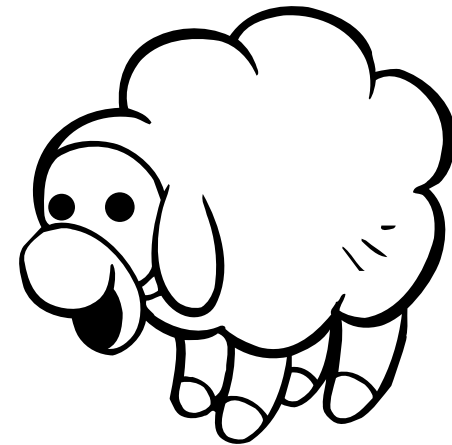

Love Each Other.

# Craft

## Review

### Sheep in the Pen

In this craft the children will build a pen with sheep inside. This craft helps to reinforce the practical ways that Jesus takes care of them.

#### Materials

*For each child:*

- 1 paper plate, 9" diameter
- handful of straw, hay, or Spanish moss
- 3 cotton balls
- glue stick

*For the teacher:*

- 1 piece of gray construction paper
- 1 piece of brown construction paper
- clear tape
- marker or fountain pen

#### Preparation

1. Write John 15:17 "Love Each Other" on the bottom of each plate.
2. Make the sheep pen as follows:
  - A. Using the ruler trace four lines across the top of the plate, as shown in Figure A.
  - B. Cut out the triangles in the four corners of the plate. See Figure B.
  - C. Fold up the sides of each paper plate along the drawn lines. Tape the corners together to make the walls of the sheep pen. See Figure C.
3. Tear the sheets of construction paper into 1" pieces. These will be rocks.
4. Mark two eyes on each cotton ball with a marker to make sheep.
5. Cut or tear the straw into pieces small enough to fit within the sheep pen.
6. Make a model following the instructions.

#### Instructions

1. Show the children the model of the sheep pen. Tell them that this is a home for the sheep, where they live, sleep and eat. Show the children the cotton ball sheep. *These sheep have no home. Would you like to build them a home, a pen just like this one?*
2. Give each child a sheep pen. Write the child's name on the bottom of his pen.
3. Have the children glue the construction paper rocks to the outside walls of the pen. See Figure D. Explain to the children that they are building a rock wall to keep the sheep inside their pens.
4. Give the children some straw to glue inside their sheep pens. *This hay is so the sheep will have a soft bed and something to eat. Sheep like to eat hay.*
5. Give the children each three sheep to glue inside their pens.

#### Conclusion

*Jesus makes sure his sheep have warm homes, soft beds and good food to eat. He loves us, and we should love each other.*

Put your ear next to the pen and pretend to listen to the sheep. *I hear the sheep! Do you know what they're saying? The sheep are saying thank you.* Have the children "listen" to their sheep, too.

#### Teacher Tips

- Since cotton pulls apart so easily, tell the children to be very gentle when playing with their sheep.
- Put the children's pens in a safe place so that they will be in good condition to take home.

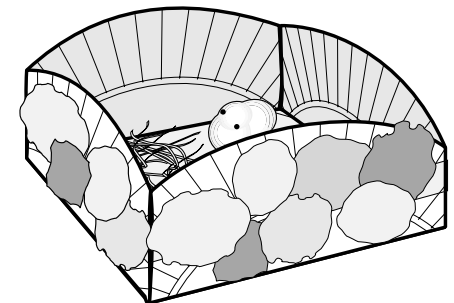
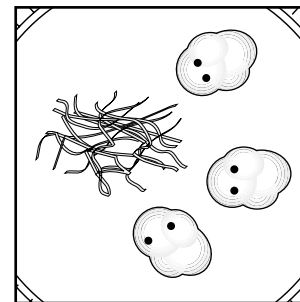

# Review

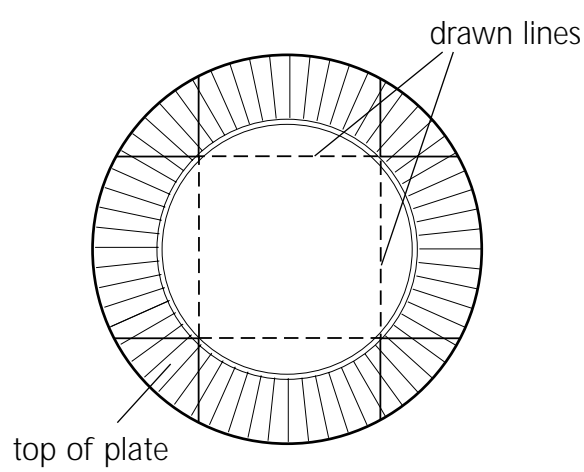

Figure A

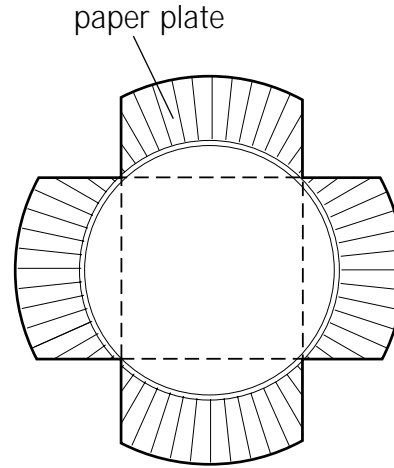

Figure B

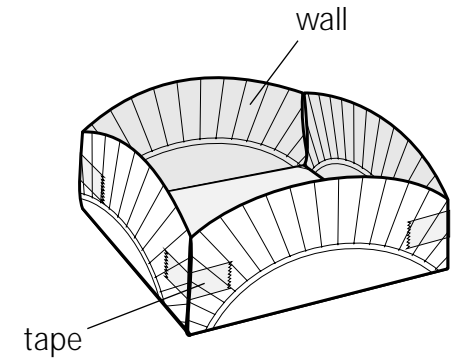

Figure C

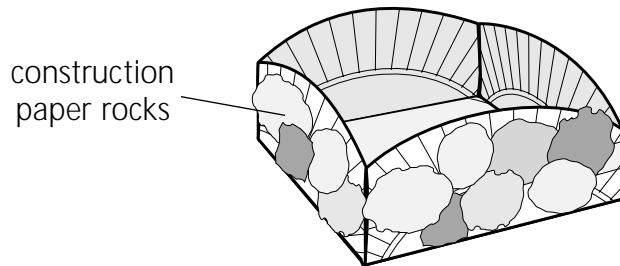
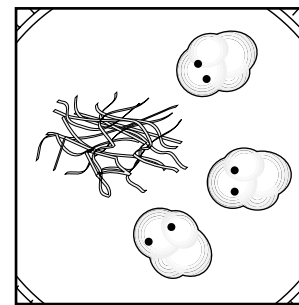
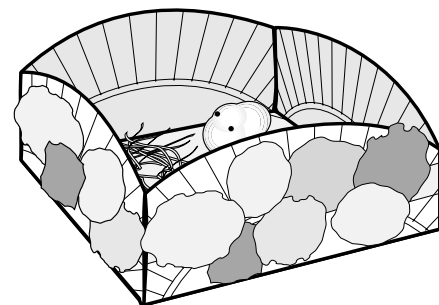

Figure D



Finished Craft







## Lesson Objectives

- The children will identify Jesus as a shepherd.
- The children will state that Jesus takes care of them by giving them families, homes, food and clothes.
- The children will thank Jesus for taking care of them.

## Bible Story Text

Ezekiel 34:11-16

## Bible Truth

“Love each other.”  
(John 15:17)

## Preclass Centers

As the children arrive, guide them to a pre-class center. Have no more than six children at each center.

### Materials

Use the materials previously selected for this unit’s preclass centers.

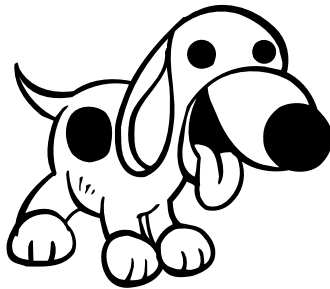

## Lesson Plan

Greeting and Registration

Preclass Activity: Preclass Centers

Welcome and Singing

Centers:

Life Application: Animal Food Game

Bible Story: Love Each Other

Craft: ‘What Do I Eat?’ Flip Book

NOTE: Be sure to allow sufficient time for a snack.

## Preparation

1. Be sure to check the condition of the materials selected for this unit’s preclass centers prior to set up. Replace any broken toys, or puzzles with missing pieces as necessary.
2. Set up the centers before the children come into the classroom.
3. Assign a teacher to each center and have the teachers stay in those centers until the singing begins.

## Instructions

Guide the play in each center reinforcing the unit theme.

## Teacher Tips

- **IMPORTANT:** Do not allow any small toys in the classroom. First check all toys for size. You can obtain a “safety cylinder” from a pediatrician. Any object that can fit into the cylinder is too small and could cause a child to choke.
- Be involved in the group play and offer guidance as needed.
- Wear comfortable clothes suitable for sitting on the floor.
- Smile! Be childlike in heart and alert in mind.

Life

Application

## Animal Food Game

This game will help the children to remember that Jesus loves and cares for all his creatures.

### Bible Truth

"Love each other."  
(John 15:17)

### Materials

*For the teacher*

- Bible
- 2 sheets of different colored construction paper
- white glue
- scissors
- laminate (optional)

*Reproducible Pages:*

- Page A, 1 copy for the teacher
- Page B, 1 copy for the teacher

### Preparation

1. Glue the copy of Reproducible Page A to one sheet of construction paper and glue the copy of Reproducible Page B to the other sheet of construction paper.
2. Cut out each of the cards.

### Instructions

1. Show the children the lamb card. *What is this animal? Yes, it is a lamb. What kind of sound does a lamb make? That's right. Lambs say, "Baaa."* Let them repeat the sound together. *What does the lamb eat? Does he like to eat candy? No! Does he like to eat ice cream? No! Does he like to eat bananas? No! He likes to eat grass!* Show the children the grass card, and then place it next to the lamb card.
2. Show the children each of the animal cards. Asking questions, as shown in the example above, help them determine what each animal eats. Match the appropriate food card with each animal card.

3. For a class of mostly twos, play the game as detailed below:
  - A. Place all of the animal cards face up on the floor or a table.
  - B. Place all of the food cards face up on the floor or a table.
  - C. Have the children take turns matching an animal card with the corresponding food card.
4. For a class of mostly threes, play the game as detailed below:
  - A. Place all the animal cards face down together on the floor or table.
  - B. Place all the food cards face down together on the floor or table.
  - C. Let each child take a turn flipping over one card from each group. Have the child determine if the animal card matches the food card. If the child has a match, have him identify the animal and what food it eats. After the child's turn have him flip the cards back so they are facing down.
  - D. Have the next child take a turn. Encourage the children after each attempt to match the cards.

### Conclusion

Open your Bible to Ezekiel 34:11-16. *Jesus makes special food for all the animals because he is a shepherd and loves them. The Bible says that Jesus is our shepherd, too! What kinds of food does he make for you?* Let the children talk about the food they like to eat.

*Since Jesus takes good care of us, we should also love each other.* Let's thank Jesus for taking care of us. *Thank you, Jesus, for giving us everything that we need.*

Many of our friends do not know that Jesus takes care of them. Who are you going to tell about Jesus?

### Teacher Tips

You may want to laminate these cards and use them again.



## Love Each Other

The children will be reminded that, just as Jesus looks for and takes care of them, they should also love each other.

### Bible Story Text

Ezekiel 34:11-16

### Materials

*For the teacher:*

- Bible
- 4 small stuffed animals or dolls including 1 lamb
- blanket to hide the lamb
- small bag of "pet" food
- food dish
- dish towel
- shoe box

### Preparation

1. Familiarize yourself with Bible story and the song from the Unit 6 Song Sheet.
2. Just prior to class, set up your teaching space as follows:
  - A. Place some pet food in the food dish.
  - B. Place the food dish and the towel into the shoe box.
  - C. Hide the "lost" lamb stuffed animal under the blanket.
  - D. Arrange all the other stuffed animals around the blanket so the lamb is better hidden.

### Finding the Lamb

Sit with the children in a circle. Place the shoe box behind you. Place the Bible on your lap and open it. *The Bible says that Jesus takes care of us like a good shepherd takes care of his sheep. He looks for us, feeds us, takes care of our "boo-boos," and gives us beds to sleep in. We can be good shepherds, too! I have a little lamb that is lost and I need your help to find it. Will you be good shepherds with me and help me find my lost lamb?*

*Look, here is an animal. Maybe he has seen my lost lamb.* Hold up one of the stuffed animals. Have the children wave and say, "Hello. We are good shepherds looking for our little lost sheep. Have you seen him?" Have the animal shake his head no. Have the children thank the animal.

*Look, here is another animal. Maybe he has seen my lost lamb.* Hold up a different stuffed animal. Have the children wave and say, "Hello. We are good shepherds looking for our little lost sheep. Have you seen him?" Have that animal shake his head no. Have the children thank the animal.

*Look, here is another animal. Maybe he has seen my lost lamb.* Hold up the last stuffed animal. Have the children wave and say, "Hello. We are good shepherds looking for our little lost sheep. Have you seen him?" Have that animal answer, "Yes, I have! Your little lost lamb was here looking for food and for a bed."

*He must be very close. Where do you think our little lost lamb could be? Do you think he might be asleep under this blanket?* Pick up the blanket to reveal the little lamb. Hug the lamb and let the children take turns hugging him as well. *Let's make a house with a bed for our lamb, and give him some food.*

Pick up the box behind you and place it in front of you. Let the children take turns pretending to feed the lamb. Talk about how Jesus makes sure that we have homes, beds and food. *Because Jesus is a good shepherd to us, we should also love each other.*

### Conclusion

*The Bible tells us that Jesus is our Good Shepherd. He looks for us and finds us, just as we found the lost lamb. Jesus also gives us a home, a bed and food to eat. We can be good shepherds, too!*

Sing "Where is My Lamb?" from the Unit 6 Song Sheet. Repeat the song each time using a different child's name.

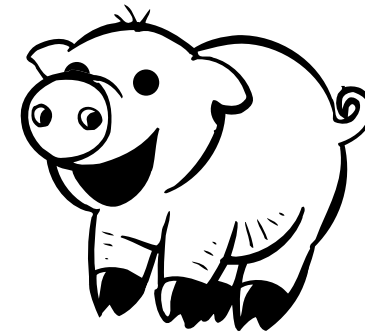

# Bible Story

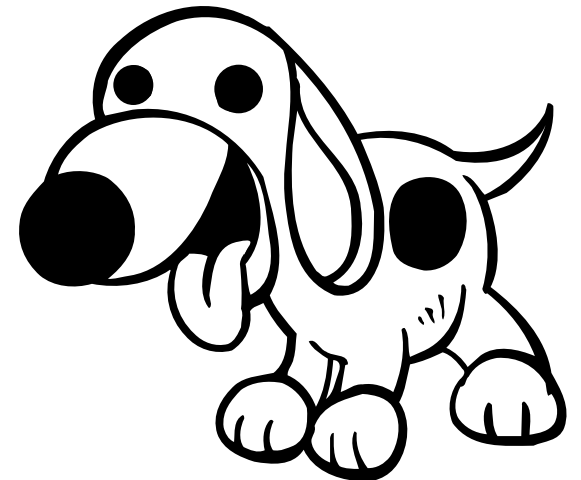
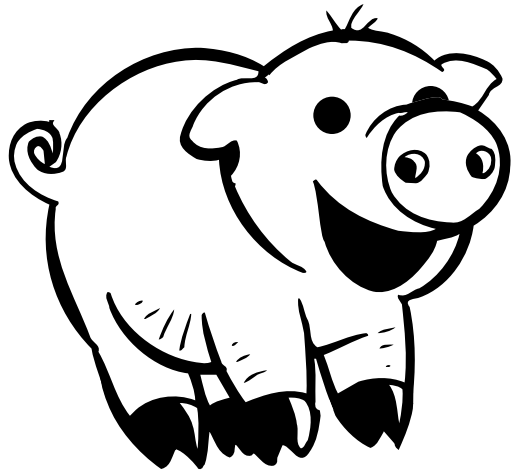
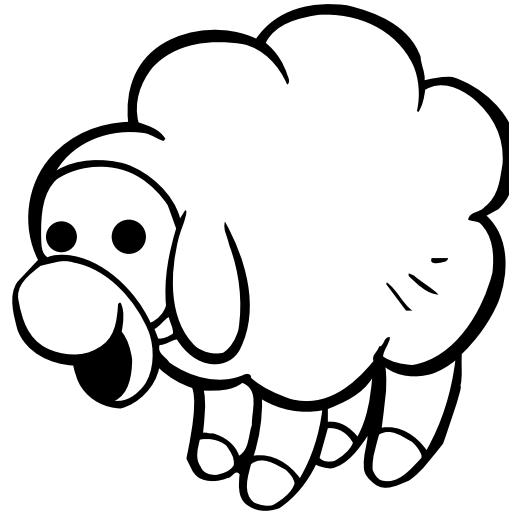
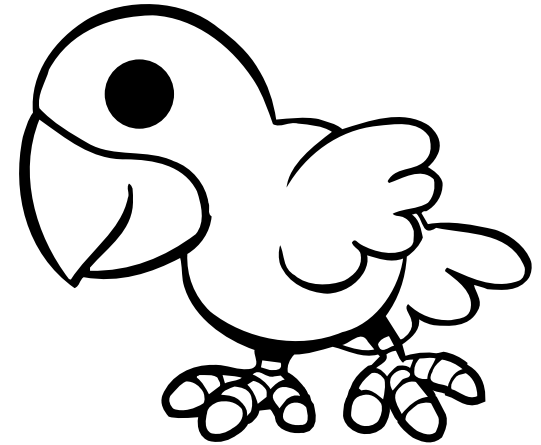
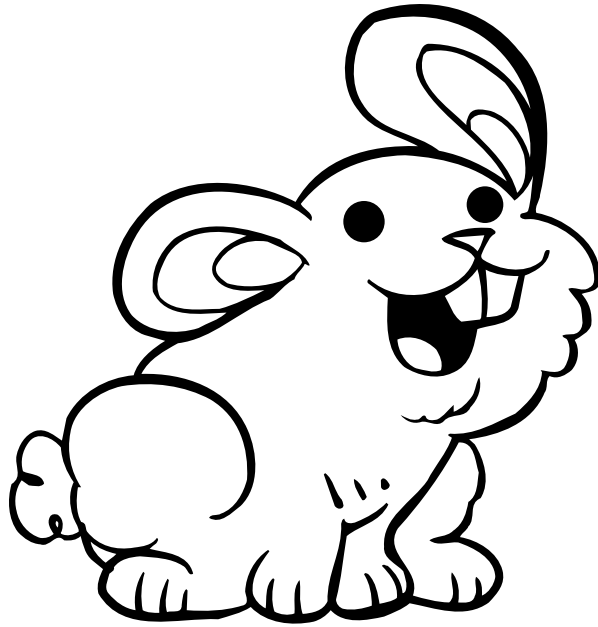

C  
r  
a  
f  
t

## 'What Do I Eat?' Flip Book

This craft will help the children identify different animals and what they eat. They will also be reminded that it is Jesus who takes care of the animals.

### Materials

*For each child:*

- 5 blank index cards, 5" x 8"
- glue stick
- 1 piece of ribbon, 8"

*For the teacher:*

- 1 piece of orange felt
- 1 piece of white felt
- brown yarn
- green yarn
- single hole punch
- scissors
- black marker
- marker
- small plastic bags

*Reproducible Pages:*

- Page C, 1 copy for each child
- Page D, 1 copy for each child

### Preparation

1. Cut out the animals from the copies of Reproducible Pages C and D.
2. Prepare the yarn for each child as follows:
  - A. Cut 2 pieces of 6" green yarn to make a "carrot top."
  - B. Cut 12 pieces of 1" green yarn to make "grass."
  - C. Cut 1 piece of 6" brown yarn to make a "worm."
3. For each child, cut the white felt into a 2" long "bone" shape.
4. Make a "carrot" for each child as follows:
  - A. Cut the orange felt into 1" x 3" triangles. Cut one for each child.
  - B. Punch a hole in the top of each carrot.
  - C. Thread the two pieces of 2" green yarn through the hole in the carrot and tie them. See Figure A.

5. Punch a hole in the top left corner of each index card.
6. For each child, write "What Do I Eat?" in the center of one index card. This will be the cover.
7. Make a model of the craft following the instructions.
8. Place the yarn, bone and carrot into a small plastic bag for each child.

### Instructions

1. Show the children your model of the craft. *This is a book that shows us what different animals eat!* Show them the different animals and food in the book. Would you like to make a book like this?
2. Give each of the children four blank index cards and four animal pictures. Help the children glue each animal to a separate page.
3. Give the children each their plastic bags. Have each child glue the following items to the appropriate pictures. See Figure B.
  - A. Glue the bone to the dog's mouth.
  - B. Glue twelve pieces of green grass in front of the lamb.
  - C. Glue the brown worm to the bird's beak.
  - D. Glue the carrot in front of the rabbit.
4. Give each child a cover.
5. Print each child's name in the upper right corner of the cover.
6. Help the children thread and tie their ribbons through the holes in the index cards to make their books.

### Conclusion

Remind the children that, just as Jesus is a shepherd and helps the animals, we should also help each other.

### Teacher Tips

If your class is large or the children are mostly twos, you may want to eliminate one or two of the book's pages.

Craft

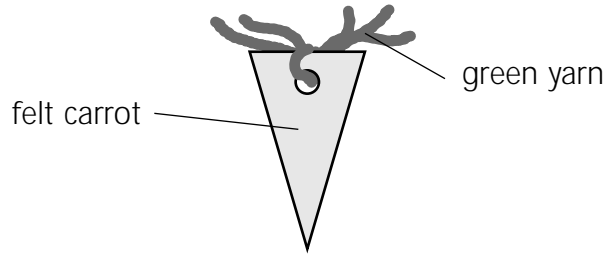
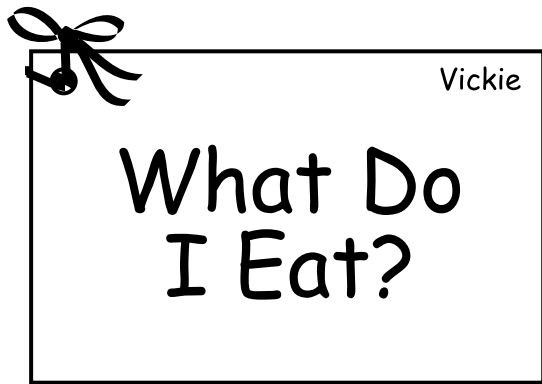

Figure A



Finished Craft

Review

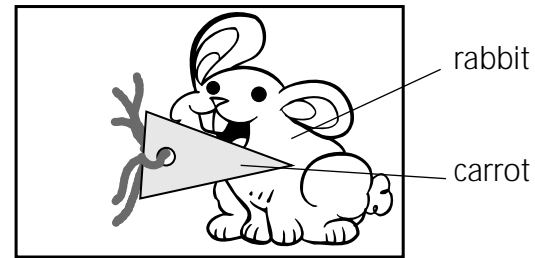
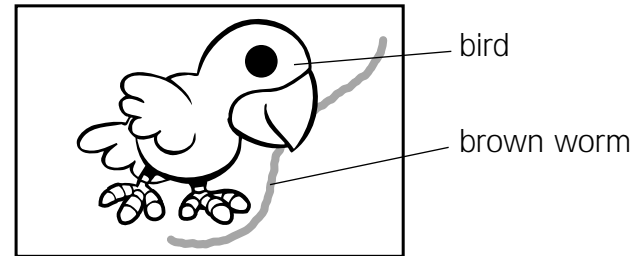
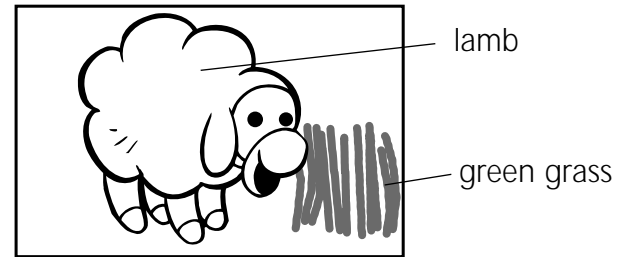
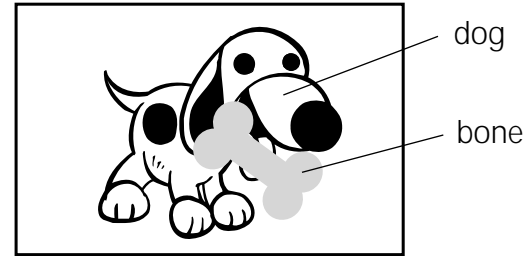

Figure B



animal cards



R  
e  
p  
r  
o  
d  
u  
c  
i  
o  
n  
e

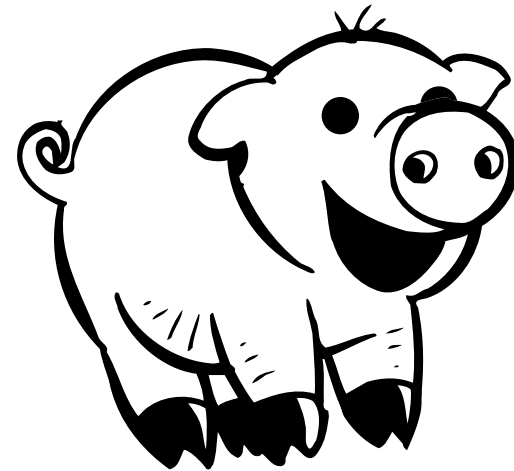
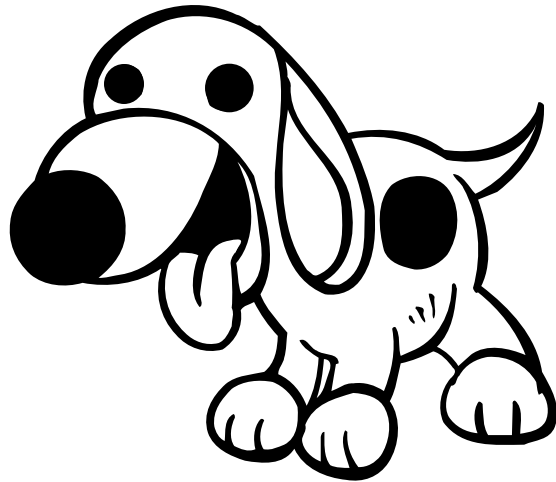
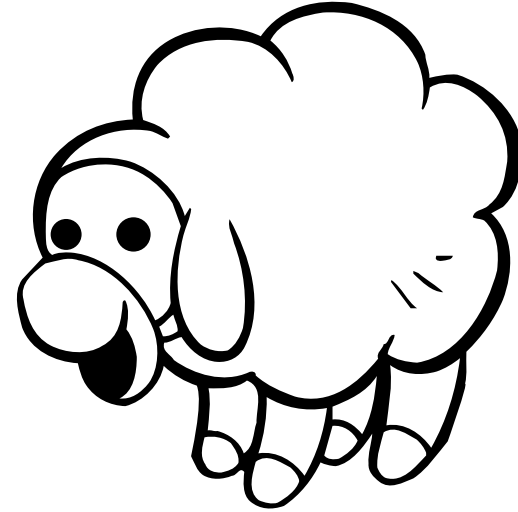
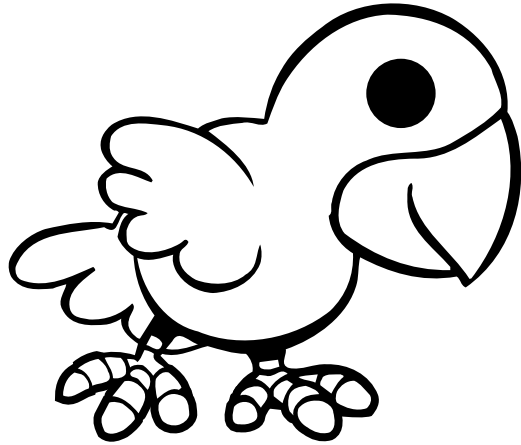



R  
e  
p  
r  
o  
d  
u  
c  
e  
d  
i  
n  
g

Supplement/Life Application

1 copy for the teacher

food cards

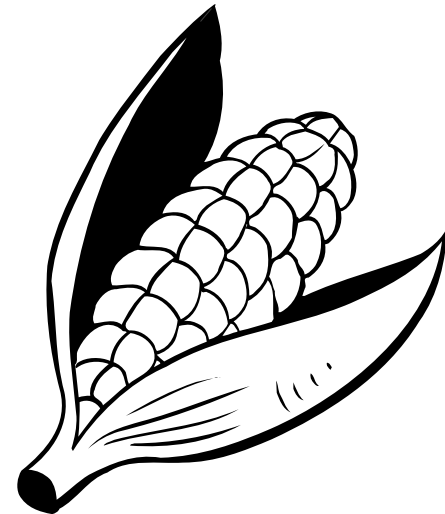
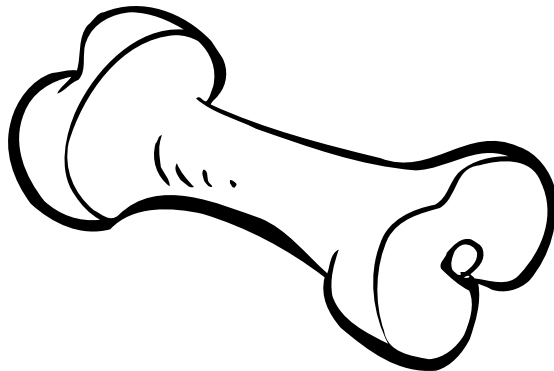
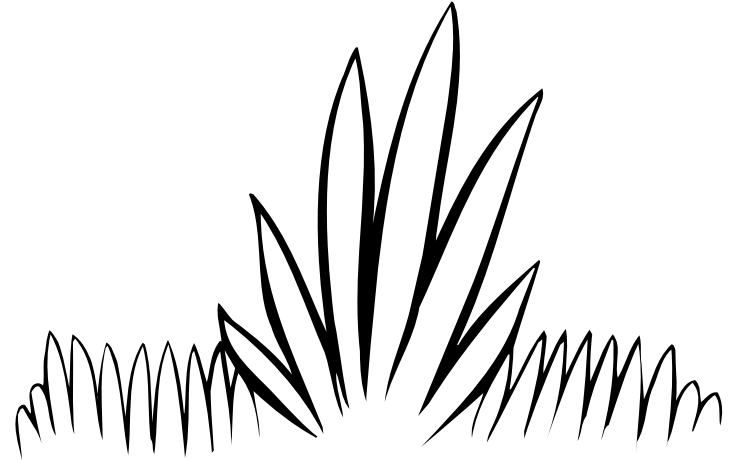
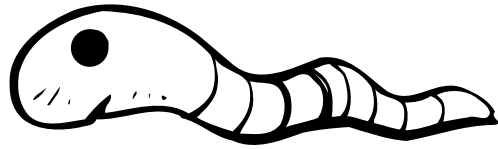





R  
e  
p  
r  
o  
d  
u  
c  
e  
d  
b  
y

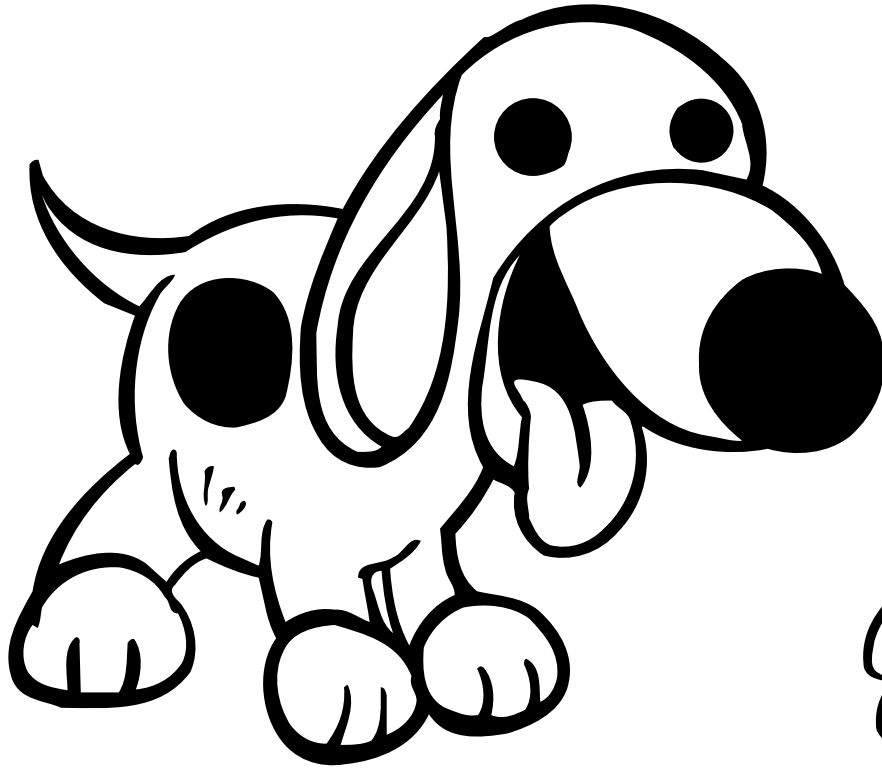

dog

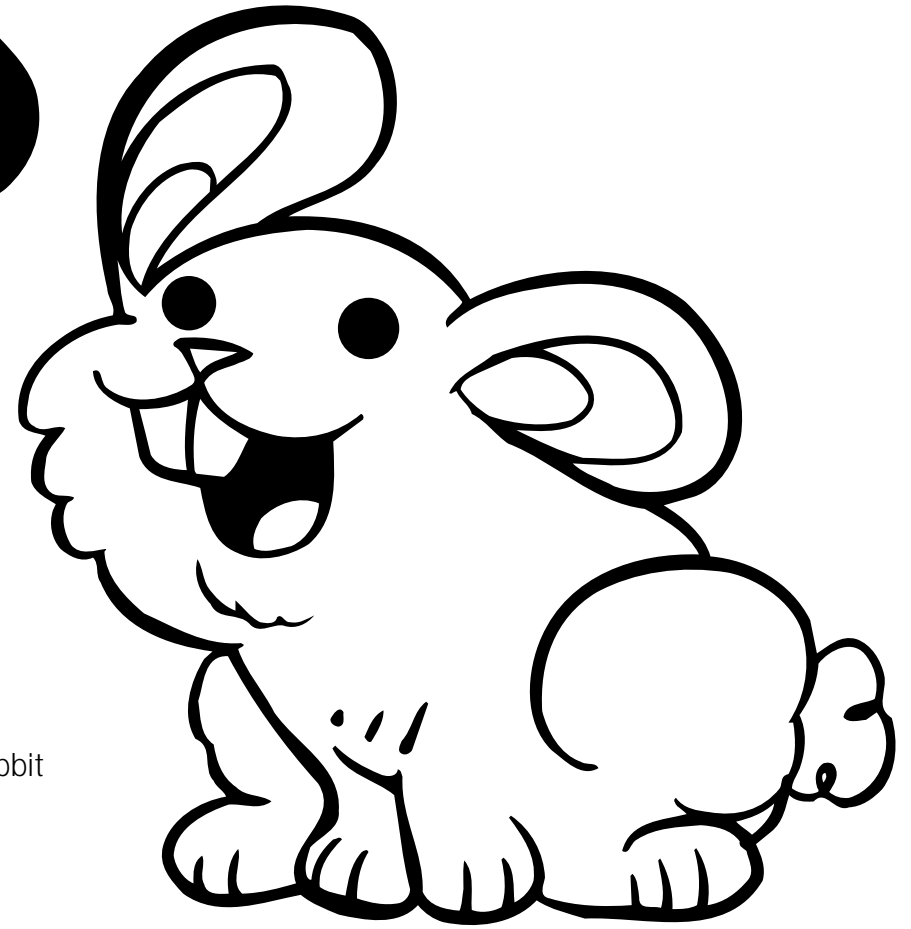

rabbit





R  
E  
P  
R  
O  
D  
U  
C  
E  
D  
B  
Y  
D  
I  
S  
C  
I  
P  
L  
E  
S  
H  
I  
P  
P  
U  
B  
L  
I  
S  
H  
I  
N  
G  
S

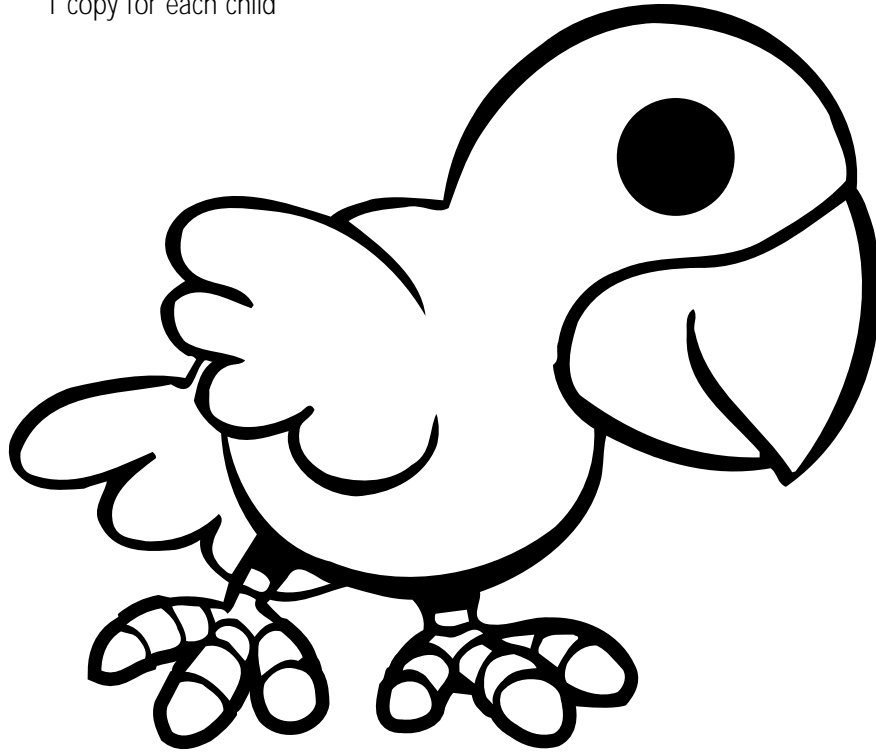

bird

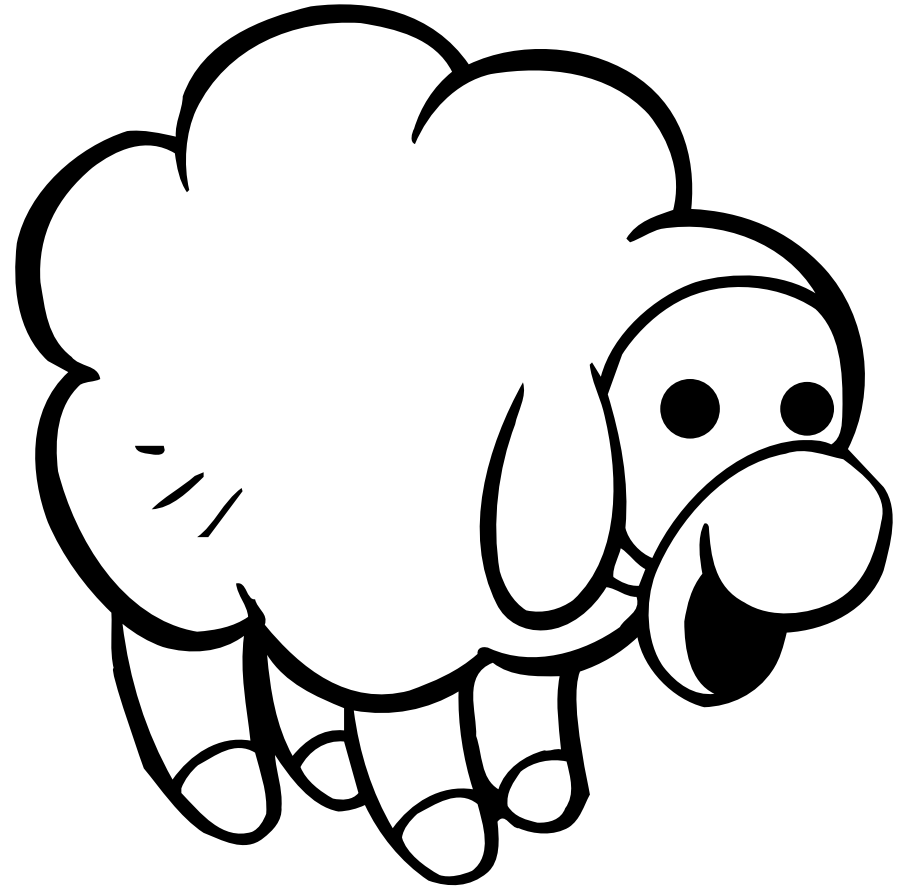

lamb

