

God's Present to Me

Jesus
Lesson 4

Lesson Objectives

- The children will state that Jesus was born in a stable.
- The children will hear the story of Jesus' birth.
- The children will thank God for sending Jesus.

Bible Story Text

Luke 2:1-7

Bible Truth

Jesus was born.
(Luke 2:6-7)

Lesson Plan

Greeting and Registration

Preclass Activity: Preclass Centers

Welcome and Singing

Centers:

Bible Story: Manger Baby

Life Application: The Best Present

Craft: Bright Star

NOTE: Be sure to allow sufficient time for a snack.

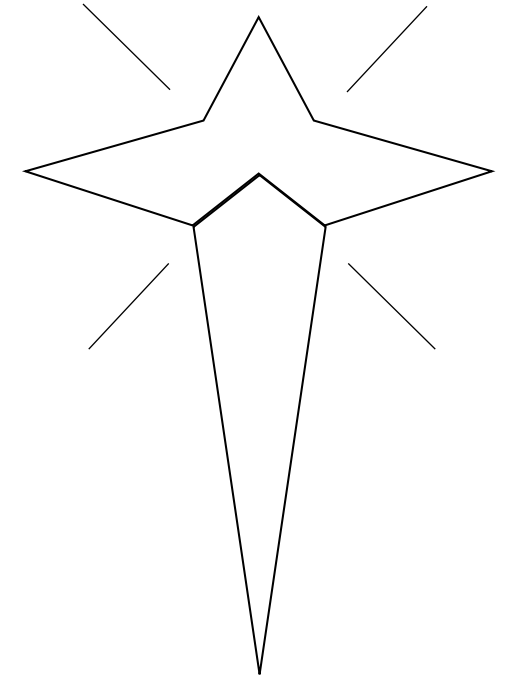

God's Present to Me

Preclass Centers

As the children arrive, guide them to a preclass center. Have no more than six children at each center.

Materials

Use the materials previously selected for this unit's preclass centers.

Preparation

1. Be sure to check the condition of the materials selected for this unit's preclass centers prior to set up. Replace any broken toys, or puzzles with missing pieces as necessary.
2. Set up the centers before the children come into the classroom.
3. Assign a teacher to each center and have the teachers stay in those centers until the singing begins.

Instructions

Guide the play in each center reinforcing the unit theme.

Teacher Tips

- **IMPORTANT:** Do not allow any small toys in the classroom. First check all toys for size. You can obtain a "safety cylinder" from a pediatrician. Any object that can fit into the cylinder is too small and could cause a child to choke.
- Be involved in the group play and offer guidance as needed.
- Wear comfortable clothes suitable for sitting on the floor.
- Smile! Be childlike in heart and alert in mind.



God's Present to Me

Manger Baby

The children will learn about the birth of Jesus.

Bible Story Text

Luke 2:1-7

Materials

For the teacher:

- angel stick puppet from Unit 4 Lesson 1, Bible Story
- Mary and Joseph stick puppets from Unit 4 Lesson 2, Bible Story
- manger picture from Unit 4 Lesson 3, Bible Story

Preparation

Read through and practice the story.

Instructions

Show the angel stick puppet. *The Bible says that an angel came to see Mary. An angel came to see Joseph. What was the good news that the angel brought to them? That's right. The good news was that baby Jesus would be born.*

Remove the angel stick puppet. *Before Jesus was born, Mary and Joseph had to go to Bethlehem. Show the Mary and Joseph stick puppets. How did they get there? Did they ride in a car? No! Maybe they went to Bethlehem riding on a donkey. Or maybe they had to walk the whole way. Did they get a nice room at an inn in Bethlehem? No! Why not? Because all the rooms were full of people. Where did they sleep? The Bible says they slept with the animals. Hold the manger scene so that all the children can see it. Let the children point out and name the different animals in the picture. You can also ask them to make different animal sounds.*

This is where baby Jesus was born. Do you see the baby? Can you find the baby's mommy? Yes, that is Mary. Can you find Joseph, the baby's daddy? Mary and Joseph took good care of baby Jesus. They put a blanket around him to keep him warm.

"Wah, wah," cried the baby. "Shh, shh," said Mary, "Don't cry." She fed him and patted him to sleep. The animals all gathered around and looked at the sleeping baby.

Conclusion

Sing the song, "Baby Jesus Was Born" from the Unit 4 Song Sheet.

Ask the following questions to review the story:

- Where was baby Jesus born? (with the animals)
- Who was his mommy? (Mary)
- Who was his daddy? (Joseph)

Teacher Tips

- If you can find a manger set, use it in place of the manger picture from Unit 4 Lesson 3, Bible Story.

God's Present to Me



God's Present to Me

The Best Present

The children will learn that babies (especially baby Jesus) are presents from God.

Bible Truth

Jesus was born.
(Luke 2:6-7)

Materials

For the teacher:

- small baby doll that can fit inside a shoe box
- doll blanket or dish towel
- wrapping paper
- tape
- scissors
- shoe box
- doll bottle (optional)

Preparation

1. Wrap the blanket around the baby doll.
2. Wrap the bottom of the shoe box with wrapping paper.
3. Place the doll inside the shoe box.
4. Practice the activity and learn the songs, so that you will be familiar with them before class.

Instructions

Who remembers what kind of news it was when baby Jesus was born? Was it good news or bad news? That's right, it was good news!

Do you know that when God gave us baby Jesus, he was giving us a present? Who likes to get presents? We ALL like to get presents, don't we? Who would like to look inside this box and see the present that God gave us?

Pass around the present and let each child look inside. As the children look inside, ask each child, *Who did God give us?* (baby Jesus)

Take the baby doll out of the box. Pass the doll to the children, and let them take turns holding baby Jesus. Encourage them to wrap the blanket around him to keep him warm, and to feed him with the bottle.

As the children take turns, sing "Baby Jesus Was Born" and "God Helps Babies" from the Unit 4 Song Sheet.

Bible Truth Activity

Who did the angel tell Mary would be born? Baby Jesus! And was he born? Yes, he was born. Jesus was born. Let's all say it together. Jesus was born.

Conclusion

Let's pray and thank God. Thank you, God, that Jesus was born. Amen.

Many people need to know the good news that Jesus was born. Who can you tell this good news to?

Teacher Tips

- Some children will not want to share the baby doll. Help them by using words like "taking turns." *First, it was Mark's turn, and now it is Meredith's turn. It will be your turn in a minute, but now it is Meredith's turn.*
- For a class of all twos, you may want to have a baby doll for each child in the center. The concept of sharing is usually not learned until a child is three.

Jesus Was Born.

God's Present to Me

Bright Star

The children will create stars to remind them of the star that led the Magi to Jesus.

Materials

For each child:

- 1 piece of blue construction paper
- star stickers, gold or silver
- glue stick

For the teacher:

- yellow construction paper
- scissors
- marker

Reproducible Pages:

- Page A, 1 copy for the teacher

Preparation

1. Cut out the star stencils from the copy of Reproducible Page A.
2. Trace and cut out "star tops" and "star bottoms" from the yellow construction paper. Cut one complete star for each child.
3. Write "Jesus Is Born" on the bottom of each piece of blue construction paper, as shown in Figure A.
4. Make a model of the craft following the instructions below.

Instructions

1. Show the children the model of the craft. *When Jesus was born, God made a star to shine brightly above the stable to help people to find him.*
2. Give each child a piece of blue construction paper and a star top.
3. Have the children glue the star tops onto the top of their papers. See Figure B.
4. Give each child a star bottom. Have the children glue these in place, as shown in Figure C.
5. Give the children star stickers and have them place these on their papers. See Figure D.
6. Write the children's names on the backs of their papers.
7. Sing "Baby Jesus Was Born" from the Unit 4 Song Sheet as the children work.

Teacher Tips

The children may not align the star pieces perfectly, but this is fine. Let them be creative.

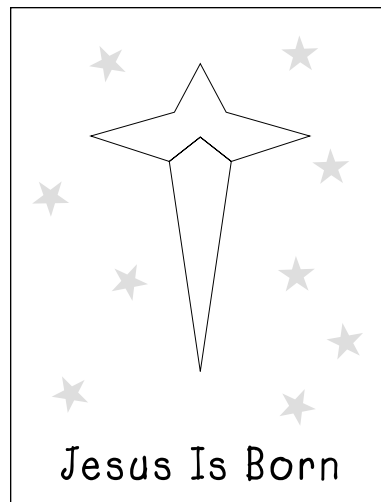

craft

God's Present to Me

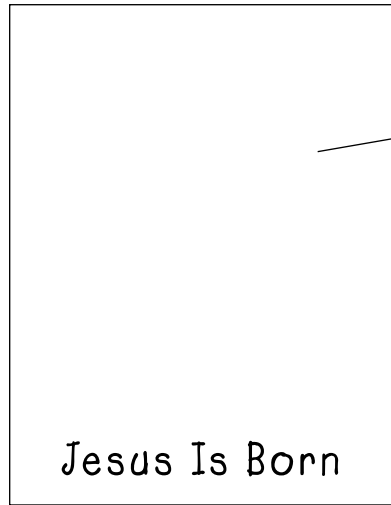

Figure A

blue
construction
paper

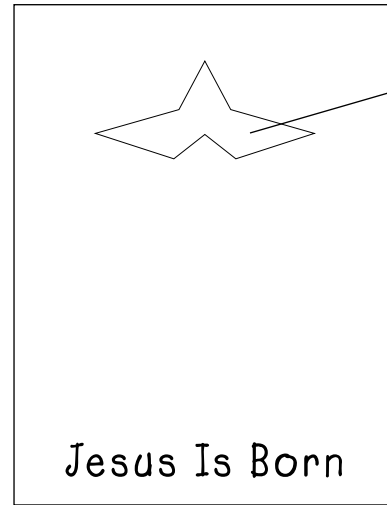

Figure B

star top

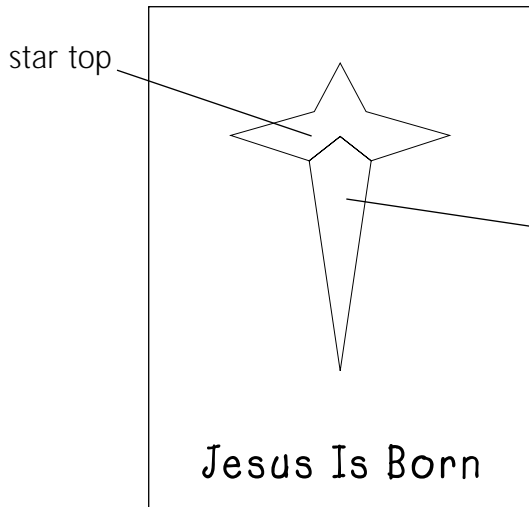

Figure C

star top

star bottom



Figure D

star stickers



God's Present to Me

Jesus
Lesson 4

Lesson at
a Glance supplement

2 and 3 Year Olds



Pre
class

activity

Lesson Objectives

- The children will state that Jesus was born in a stable.
- The children will hear the story of Jesus' birth.
- The children will thank God for sending Jesus.

Bible Story Text

Luke 2:1-7

Bible Truth

Jesus was born.
(Luke 2:6-7)

Preclass Centers

As the children arrive, guide them to a preclass center. Have no more than six children at each center.

Materials

Use the materials previously selected for this unit's preclass centers.

Lesson Plan

Greeting and Registration

Preclass Activity: Preclass Centers

Welcome and Singing

Centers:

Life Application: In a Stable

Bible Story: Manger Baby

Craft: No Room in the Inn

NOTE: Be sure to allow sufficient time for a snack.

Preparation

1. Be sure to check the condition of the materials selected for this unit's preclass centers prior to set up. Replace any broken toys, or puzzles with missing pieces as necessary.
2. Set up the centers before the children come into the classroom.
3. Assign a teacher to each center and have the teachers stay in those centers until the singing begins.

Instructions

Guide the play in each center reinforcing the unit theme.

Teacher Tips

- **IMPORTANT:** Do not allow any small toys in the classroom. First check all toys for size. You can obtain a "safety cylinder" from a pediatrician. Any object that can fit into the cylinder is too small and could cause a child to choke.
- Be involved in the group play and offer guidance as needed.
- Wear comfortable clothes suitable for sitting on the floor.
- Smile! Be childlike in heart and alert in mind.

Life

Application

In a Stable

The children will pretend to be animals in the stable where baby Jesus was born. This activity will emphasize that Jesus was born with the animals.

Bible Truth

Jesus was born.
(Luke 2:6-7)

Materials

For the teacher:

- small piece of poster board or cardboard
- scissors
- aluminum foil
- table or large cardboard box, large enough to fit one child
- large sheet or tablecloth, large enough to hang over three sides of the table
- small baby doll
- baby blanket
- open shoe box or other box to hold baby doll
- tape

Preparation

1. Cut a star out of the poster board and cover it with aluminum foil.
2. Wrap the baby in the blanket and place it in the shoe box.
3. Drape the sheet over three of the sides of the table to form a "stable."
4. Place the shoe box with the baby doll inside the stable.
5. Tape the star to the top edge of the table.

Instructions

1. Ask the children what animals were in the stable when Jesus was born.
2. Pretend to act out each animal along with the children.
3. Sing "In Bethlehem There Was a Barn" from the Unit 4 Song Sheet.

Bible Truth Activity

Hold the baby doll in your arms. *What was the baby's name who was born in the stable? His name was Jesus. Jesus was born. Let's all say it together: Jesus was born. Jesus was a special baby. He was God's son!*

Conclusion

Let's pray. Thank you, God, for giving us Jesus. Amen.

Many people need to know about Jesus being born. Who can you tell?

Teacher Tips

- Some children will not want to share the baby doll. Help them by using words like "taking turns." *First, it was Mark's turn, and now it is Meredith's turn. It will be your turn in a minute, but now it is Meredith's turn.*
- For a class of all twos, you may want to have a baby doll for each child in the center. The concept of sharing is usually not learned until a child is three.

Manger Baby

The children will learn about the birth of Jesus.

Bible Story Text

Luke 2:1-7

Materials

For the teacher:

- angel stick puppet from Unit 4 Lesson 1, Bible Story
- Mary and Joseph stick puppets from Unit 4 Lesson 2, Bible Story
- manger picture from Unit 4 Lesson 3, Bible Story

Preparation

Read through and practice the story.

Instructions

Show the angel stick puppet. *The Bible says that an angel came to see Mary. An angel came to see Joseph. What was the good news that the angel brought to them? That's right. The good news was that baby Jesus would be born.*

Remove the angel stick puppet. *Before Jesus was born, Mary and Joseph had to go to Bethlehem. Show the Mary and Joseph stick puppets. How did they get there? Did they ride in a car? No! Maybe they went to Bethlehem riding on a donkey. Or maybe they had to walk the whole way. Did they get a nice room at an inn in Bethlehem? No! Why not? Because all the rooms were full of people. Where did they sleep? The Bible says they slept with the animals. Hold the manger scene so that all the children can see it. Let the children point out and name the different animals in the picture. You can also ask them to make different animal sounds.*

This is where baby Jesus was born. Do you see the baby? Can you find the baby's mommy? Yes, that is Mary. Can you find Joseph, the baby's daddy? Mary and Joseph took good care of baby Jesus. They put a blanket around him to keep him warm.

"Wah, wah," cried the baby. "Shh, shh," said Mary, "Don't cry." She fed him and patted him to sleep. The animals all gathered around and looked at the sleeping baby.

Save the manger scene for Unit 4 Lesson 4.

Conclusion

Sing the song, "Baby Jesus Was Born" from the Unit 4 Song Sheet.

Ask the following questions to review the story:

- Where was baby Jesus born? (with the animals)
- Who was his mommy? (Mary)
- Who was his daddy? (Joseph)

Teacher Tips

- If you can find a manger set, use it in place of the manger picture from Unit 4 Lesson 3, Bible Story.



C
r
a
f
t

No Room in the Inn

The children will make manger scenes to remind them that baby Jesus was born in a manger.

Materials

For each child:

- 1 piece of light-colored construction paper
- 3 large craft sticks, 6"
- crayons
- glue

For the teacher:

- dark-colored construction paper
- small bag of hay found in a craft store

Reproducible Page:

- Page B, 1 copy for each child
- Page C, 1 copy for the teacher

Preparation

1. Cut out the manger poems from the copies of Reproducible Page B.
2. Cut out the stencil of baby Jesus from the copy of Reproducible Page C.
3. Trace the stencil onto dark-colored construction paper and cut out one for each child.
4. Prepare three craft sticks for each child, as follows. See Figure A.
 - A. Cut the first craft stick in half. Each half will be 3" long. Cut one of the halves into three, 1" equal pieces. Dispose of the piece with the rounded end.
 - B. Cut the second craft stick in half. Each half will be 3" long.
 - C. Leave the third 6" long craft stick intact.
5. Make a model of the craft following the instructions.

Instructions

1. Give each of the children a piece of light-colored construction paper.
2. Give the children each a manger poem, and have them glue it to the middle of their papers.
3. Help each child to glue the craft sticks around the manger poem, as shown in Figure B.
4. Read and discuss the manger poem with the children as they work.
5. Help the children to glue the baby Jesus above the top stick as shown in Figure C. Explain to the children that this is the baby Jesus asleep in his manger.
6. Give each child a small amount of hay to glue to the top stick. Explain that a manger is a box of hay for the animals to eat from. Tell them that the hay made a soft, warm bed for baby Jesus.
7. As you work, you can sing "Away in a Manger" from the Unit 4 song sheet.

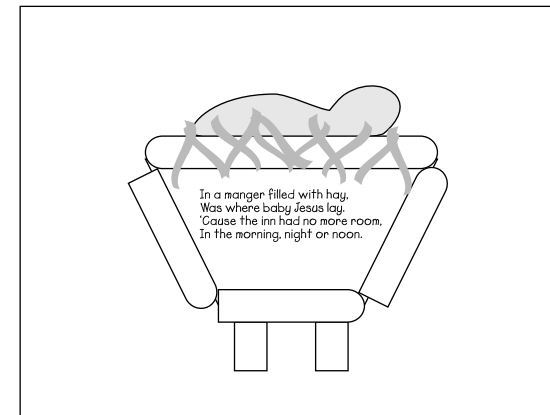

C
r
a
f
t

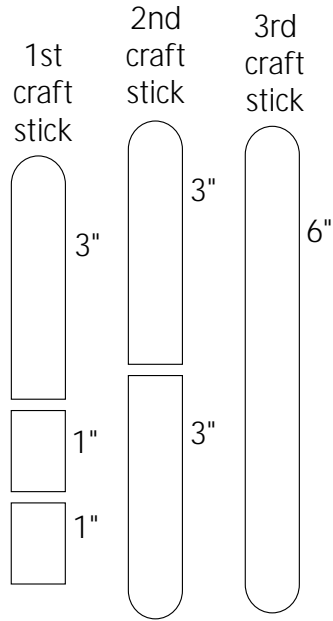

Figure A

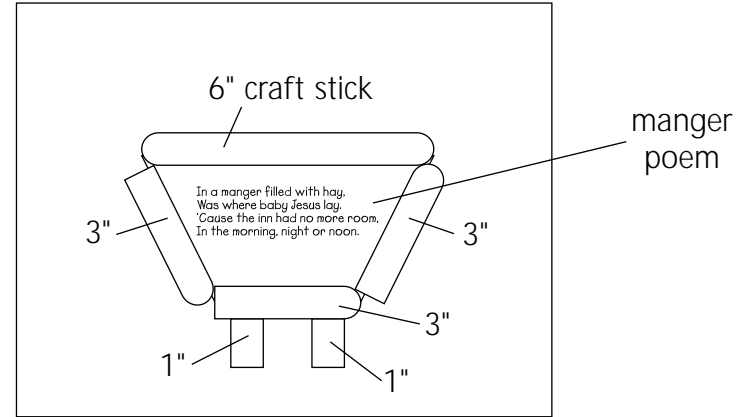

Figure B

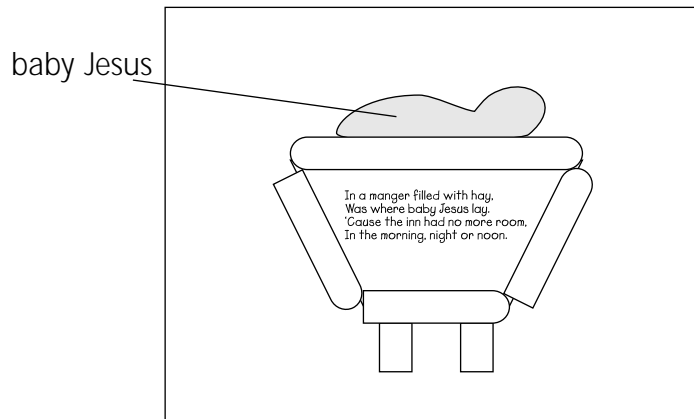
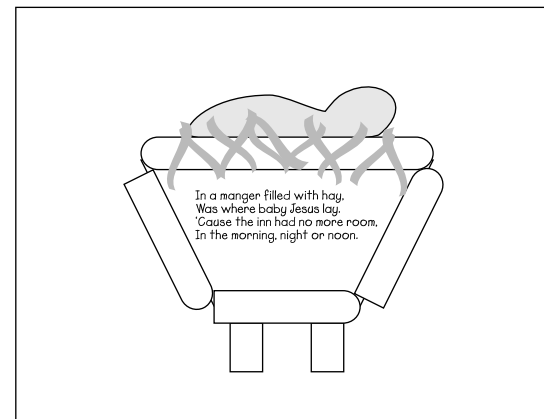

Figure C



Finished Craft





R
e
p
r
o
d
u
c
i
b
l
e

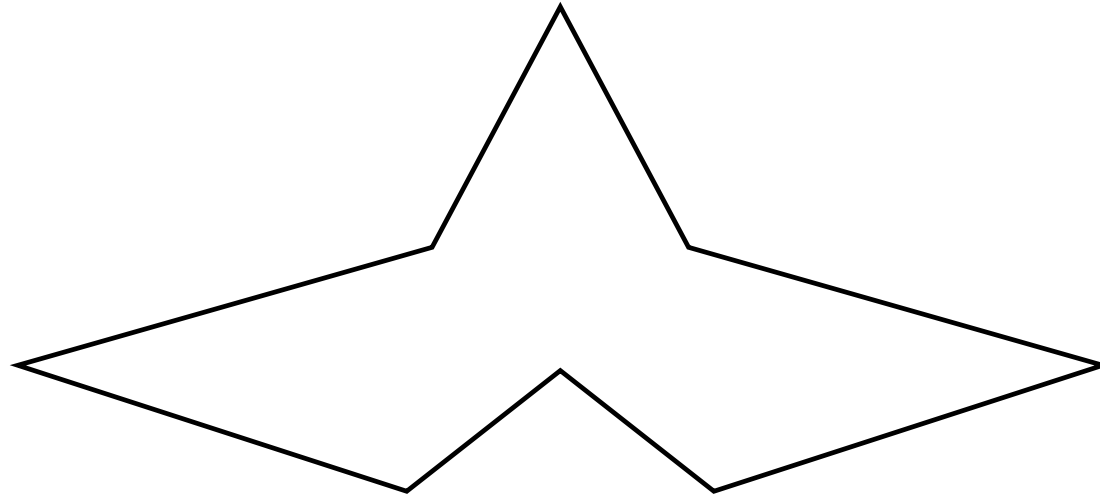

'star top' stencil

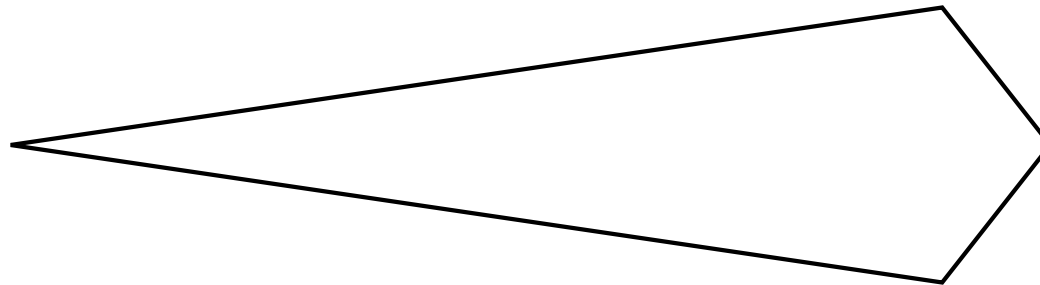

'star bottom' stencil





R
e
p
r
o
d
u
c
i
b
l
e

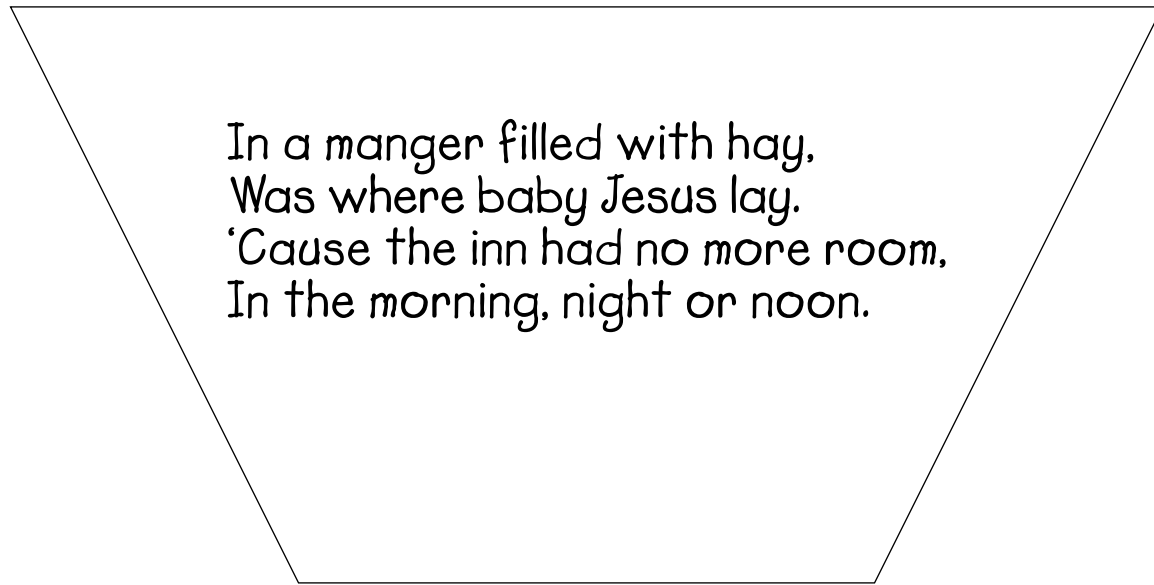

In a manger filled with hay,
Was where baby Jesus lay.
'Cause the inn had no more room,
In the morning, night or noon.

manger poem





R
e
p
r
o
d
u
c
i
b
l
e

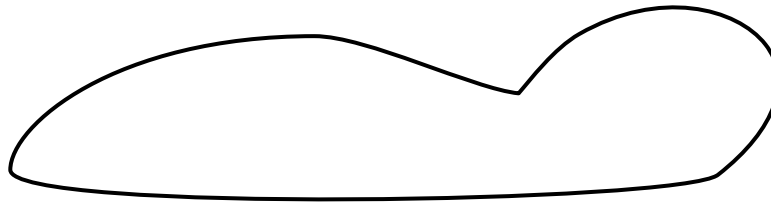

baby Jesus stencil

