

To Bethlehem

Lesson Objectives

- The children will state that Jesus was born in a stable.
- The children will hear the story about Mary and Joseph traveling to Bethlehem.
- The children will thank God for the good news of Jesus' birth.

Bible Story Text

Luke 2:1-7

Bible Truth

Jesus was born.
(Luke 2:6-7)

Lesson Plan

Greeting and Registration

Preclass Activity: Christmas Present and Preclass Centers

Welcome and Singing

Centers:

Bible Story: Mary and Joseph Take a Trip

Life Application: Good News for David and Lesli

Craft: Donkey on a Stick

NOTE: Be sure to allow sufficient time for a snack.



To Bethlehem

Christmas Present

The children will continue making Christmas presents during this special month-long activity.

Materials

For each child:

- poster board
- markers and crayons
- finished frames from Unit 4 Lesson 1, Preclass Activity

For the teacher:

- gold spray paint
- scissors
- box to store and transport the craft

Preparation

1. Spray paint the finished frames gold.
2. Cut the poster board into 4½" x 5" squares. Cut one square for each child.

Instructions

1. Give the children markers or crayons and a piece of poster board.
2. Have the children draw a picture on their poster board.
3. Collect any pictures the children may have brought to class with them.
4. Place their drawings and pictures in the box to store them until next week.

Teacher Tips

Be sure to spray paint a few extra frames for children who may come to class later.

Preclass Centers

As the children arrive, guide them to a preclass center. Have no more than six children at each center.

Materials

Use the materials previously selected for this unit's preclass centers.

Preparation

1. Be sure to check the condition of the materials selected for this unit's preclass centers prior to set up. Replace any broken toys, or puzzles with missing pieces as necessary.
2. Set up the centers before the children come into the classroom.
3. Assign a teacher to each center and have the teachers stay in those centers until the singing begins.

Instructions

Guide the play in each center reinforcing the unit theme.

Teacher Tips

- **IMPORTANT:** Do not allow any small toys in the classroom. First check all toys for size. You can obtain a "safety cylinder" from a pediatrician. Any object that can fit into the cylinder is too small and could cause a child to choke.
- Be involved in the group play and offer guidance as needed.
- Wear comfortable clothes suitable for sitting on the floor.
- Smile! Be childlike in heart and alert in mind.

To Bethlehem

Jesus
Lesson 2

Mary and Joseph Take a Trip

The children will learn about Mary and Joseph traveling to Bethlehem where Jesus was born.

Bible Story Text

(Luke 2:1-7)

Materials

For the teacher:

- poster board
- glue
- tape
- 2 craft sticks
- scissors
- washable markers
- laminate or clear contact paper
- angel stick puppet from Unit 4 Lesson 1, Bible Story

Reproducible Pages:

- Page A, 1 copy for the teacher

Preparation

1. Glue the copy of the Reproducible Page A to the poster board and cut out the figures of Mary on a donkey and Joseph.
2. Color the figures and cover them with laminate.
3. Tape craft sticks to the backs of the figures.

Instructions

Show the children the angel stick puppet.

The angel told Mary and Joseph good news! Do you remember what the good news was? Yes, they were going to have a little baby. Before the baby came, though, they had to take a trip. Did you ever go on a trip? Where did you go? Did you go on a vacation? Did you go and see Grandma?

Mary and Joseph got ready to leave on their trip. They packed their clothes and left. How do you think they traveled? Did they have a car? No. Maybe Mary rode on a donkey. Show the stick puppet of Mary on the donkey. The donkey's feet went, "Clap, clap." Can you say that with me? "Clap, clap." Move the Mary on the donkey stick puppet. Joseph walked beside Mary. Show the Joseph stick puppet.

They were traveling to Bethlehem. The King had said that everyone had to go there to be counted. "Clap, clap." It was a long way.

"Clap, clap." Mary was tired. "Are we there, yet?", she asked.

"Almost," said Joseph, "When we get to Bethlehem we will get a nice room and you can rest." Move both of the stick puppets along.

Soon they came to Bethlehem. Joseph smiled and said, "Look, Mary, there is the inn." An inn is a place where people can spend the night when they travel. "Oh, Joseph, I am so happy we are here. I need to lie down on the bed and take a rest."

Joseph knocked on the door. "Knock, knock." The innkeeper opened the door and said, "I'm sorry, there are no more empty rooms. They are all filled with people spending the night." Joseph was sad. There was no place for Mary to rest. He started to walk away. Move the stick puppets slowly. "Why don't we sleep with the animals where it is warm and dry?" said Joseph. That is where Jesus was born.

Say that with me, Jesus was born. That's very good.

Save the Mary and Joseph stick puppets for use during Unit 4 Lesson 3, Bible Story.

Conclusion

Ask the following questions to the children to review the story:

- Who was born? (Jesus)
- Where was he born? (with the animals)
- What is an inn? (a place where people sleep when they travel)
- Where did Mary and Joseph sleep? (with the animals)
- Did Jesus have a crib when he was born? (No, he was put in a manger.)

Let's sing a song about Jesus. Sing "Baby Jesus Was Born" from the Unit 4 Song Sheet.



To Bethlehem

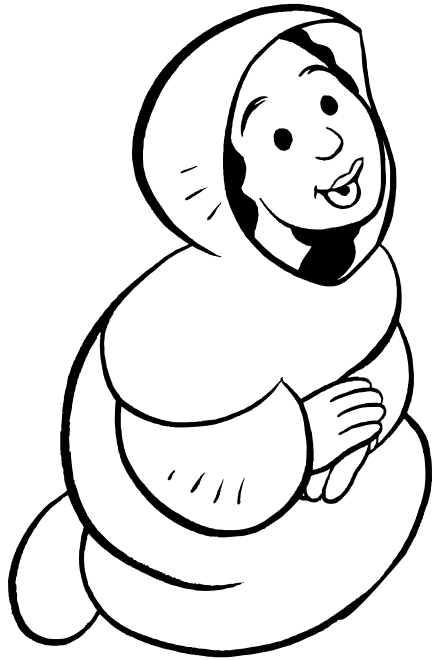

To Bethlehem

Good News for David and Lesli

The children will learn that a child's birth is good news. They will also be reminded of the good news of Jesus' birth.

Bible Truth

Jesus was born.
(Luke 2:6-7)

Materials

For the teacher:

- felt board with a black background
- felt board figures and props from Unit 4 Lesson 1, Life Application

Preparation

Review telling the story in this activity using the felt board figures.

Instructions

Show the children each figure and explain who they are in their family: the daddy; the mommy; the brother, David; and the sister, Lesli. Sing "My Own Loving Family" from the Unit 4 Song Sheet, as you hold up each of the felt board figures.

Tell the following story, moving the figures on the felt board to act out the actions. *David and Lesli were outside kicking a ball. David kicked the ball to Lesli, and Lesli kicked the ball back to her brother. They played for a little while, and then David remembered the new baby next door. "Let's go look at the baby," he said to Lesli. "Mommy, Mommy!" they both called. "Can we go see the new baby?" "Yes," said Mommy, "we will all go together and see the baby when Daddy gets home."*

Daddy and Mommy are helping their neighbors to learn about God. After Daddy came home, they all went over to visit the neighbors. Mommy brought them a present for their new baby.

After their visit to the neighbors, they all came home and it was bedtime. Daddy and Mommy tucked David and Lesli into their beds, and read to them from the Bible. He read about the little baby that Mary would have named Jesus. The angel in the Bible said this was good news! After reading the Bible story, Daddy said, "We have some good news to tell you. How would you like it if we had a new baby at OUR house?" David and Lesli were very excited. "Really, Daddy?" said David. "Yes," said Daddy. "We are going to have a

new baby." Daddy and Mommy looked very happy. "Is it a boy or a girl?" asked Lesli. "We don't know yet," said Mommy.

"Now, it is time to pray," said Daddy. "Lesli, would you like to say our prayer?" "Yes," said Lesli. "Thank you, God, for Daddy, Mommy, David and me. Thank you for our good news. Thank you for our new baby brother or sister."

Daddy and Mommy kissed and hugged David and Lesli, and then they turned out the light. David and Lesli lay in their beds happily thinking about their new baby. It would be fun to have a little brother to play baseball with, David thought. It would be fun to have a sister to play dolls with, Lesli thought. They both agreed that having a new baby was very good news!

Bible Truth Activity

What was David and Lesli's good news? That's right. They were going to have a new baby in their family. Does anyone remember the good news the angel told to Joseph? The angel said, "Mary will have a baby, and the baby will be Jesus" (Matthew 1:21). The Bible says, Jesus was born. Let's all say this together: Jesus was born.

Conclusion

Let's thank God for the good news. Thank you, God, for the good news of Jesus' birth.

Who are you going to tell about Bible class today? Other people need to know the good news that Jesus was born.

Jesus Was Born.

To Bethlehem

Donkey on a Stick

The children will make toy donkeys that will remind them of Mary and Joseph traveling to Bethlehem.

Materials

For each child:

- 1 piece of gray or brown construction paper
- 1 paint stick from a paint or hardware store
- yarn: brown, gray or black
- blue or red ribbon, 1/2" width
- glue stick

For the teacher:

- white construction paper
- black construction paper
- pink construction paper
- scissors
- black marker

Reproducible Pages:

- Page B, 1 copy for the teacher

Preparation

1. Cut out the donkey head, ear, and eye stencils from the copy of Reproducible Page B.
2. For each child, trace and cut out the following:
 - A. Cut out two donkey heads from the gray construction paper.
 - B. Cut out one eye from the white construction paper.
 - C. Cut out one ear from pink construction paper.
3. Using only one of the donkey heads per child, make the donkeys' facial features, as follows. See Figure A.
 - A. Draw a smile with the black marker.
 - B. Using the marker, make a black circle in the white eye.
 - C. Glue the eye onto the head.
4. For each child, cut out two pieces of ribbon: 3" and 5" long.
5. Cut twelve pieces of yarn each 1 1/2" long, for each child.
6. Cut a strip of paper, 8" x 3/4", for each child.
7. Write on each strip of paper, "Mary and Joseph Went to Bethlehem."
8. Make a model of the craft following the instructions.

Instructions

1. Show the children the model and remind them of the Bible Story. *Who may have ridden a donkey in the Bible Story? That's right, Mary and Joseph.*
2. Give each child one blank donkey head.
3. Help the children glue their yarn and paint sticks onto the donkeys' heads. See Figure B.
4. Give the children each a donkey head with facial features. Help them glue the two heads together, as shown in Figure C.
5. Help the children glue on the pink ear and both pieces of ribbon, as shown in Figure D.
6. Give each child a strip of paper with, "Mary and Joseph Went to Bethlehem." written on it. Have them glue these onto the paint sticks.

Conclusion

Sing "Mary Went Riding" from the Unit 4 Song Sheet. Let the children pretend to "ride" their donkeys as you sing together.

Teacher Tips

- Be sure that you put the smile and the eye on the same side of each donkey head.
- To simplify the craft for very young twos, eliminate the bridle and glue the ear on before class.
- This is a great craft for a "bring your neighbor day."

To Bethlehem

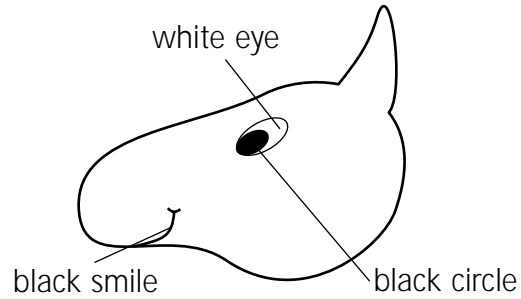

Figure A

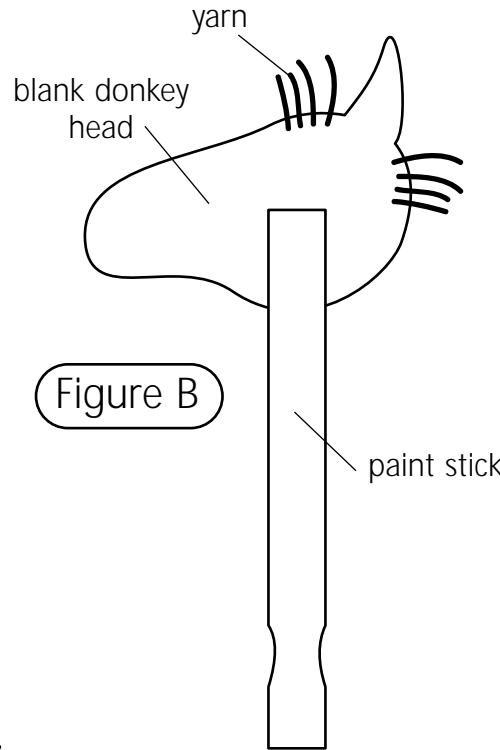

Figure B

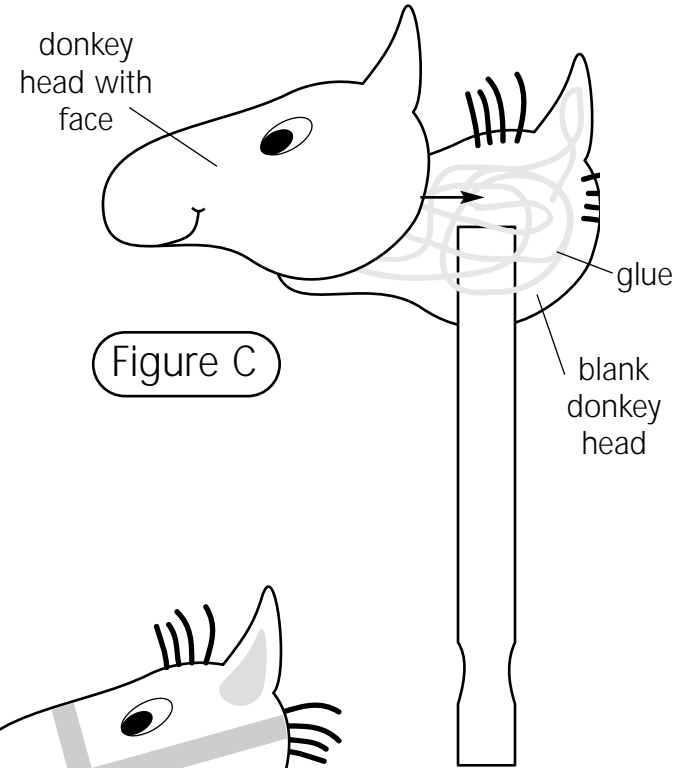

Figure C

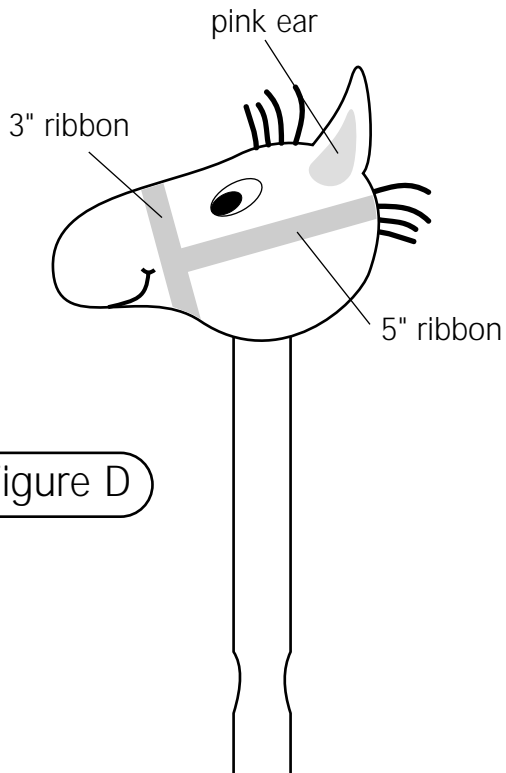
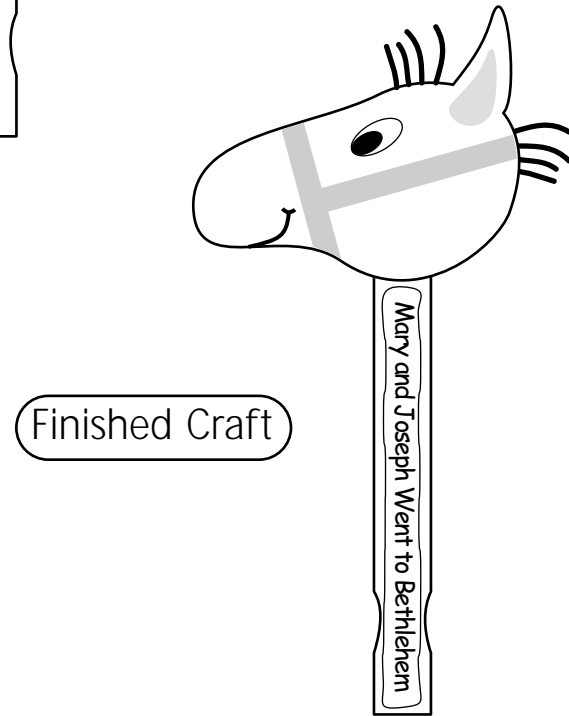

Figure D



Finished Craft





Lesson Objectives

- The children will state that Jesus was born in a stable.
- The children will hear the story about Mary and Joseph traveling to Bethlehem.
- The children will thank God for the good news of Jesus' birth.

Bible Story Text

Luke 2:1-7

Bible Truth

Jesus was born.
(Luke 2:6-7)

Preclass Centers

As the children arrive, guide them to a pre-class center. Have no more than six children at each center.

Materials

Use the materials previously selected for this unit's preclass centers.

Preparation

1. Be sure to check the condition of the materials selected for this unit's preclass centers prior to set up. Replace any broken toys, or puzzles with missing pieces as necessary.
2. Set up the centers before the children come into the classroom.
3. Assign a teacher to each center and have the teachers stay in those centers until the singing begins.

Instructions

Guide the play in each center reinforcing the unit theme.

To Bethlehem

Jesus

Lesson 2

Lesson Plan

Greeting and Registration

Preclass Activity: Preclass Centers

Welcome and Singing

Centers:

Life Application: Good News, Bad News

Bible Story: Mary and Joseph Take a Trip

Craft: Packing for a Trip

NOTE: Be sure to allow sufficient time for a snack.

Teacher Tips

- **IMPORTANT:** Do not allow any small toys in the classroom. First check all toys for size. You can obtain a "safety cylinder" from a pediatrician. Any object that can fit into the cylinder is too small and could cause a child to choke.
- Be involved in the group play and offer guidance as needed.
- Wear comfortable clothes suitable for sitting on the floor.
- Smile! Be childlike in heart and alert in mind.

Good News, Bad News

The child will respond to routine situations that happen in their lives by saying “good news” or “bad news” and holding up the corresponding paper plate face. This activity will reinforce the lesson that Jesus’ birth was good news!

Bible Truth

Jesus was born.
(Luke 2:6-7)

Materials

For the teacher:

- Paper Plate Faces from Unit 4 Lesson 1, Life Application
- marker

Preparation

Familiarize yourself with the activity.

Instructions

Who likes to be happy? Michael, do you like to be happy? Elizabeth, do you like to be happy? What do we do when we are happy? We smile! We sing!

Sing “If You’re Happy and You Know It” from the Unit 4 Song Sheet.

Show the children a Paper Plate Face. *When we hear good news, does it make us happy or sad? Happy!* Show the children the “happy face” side of the plate. *When we hear some bad news, does it make us happy or sad? Sad.* Show the “sad face” side of the plate.

Give one plate to each child and keep one for yourself. *Can you show me your good news face? Can you show me your bad news face?*

Let’s pretend. I will tell you some news, and you can tell me if it is good news or bad news.

To Bethlehem

Jesus Lesson 2

Let the children respond to the following questions with their paper plate faces. Prompt them, if necessary, by showing them the correct face with your paper plate face.

- Mommy says, “I love you!”
- Daddy says, “Sorry, but we can’t go to the park today.”
- Grandma says, “Let’s go get some ice cream!”
- Your friend says, “You are not my friend.”
- Your friend says, “I am sorry. You ARE my friend.”
- Your friend says, “I will go to church with you.”
- Your friend is sick.
- Daddy says, “Let’s play!”
- Your mommy’s friend gets baptized!
- Mommy says, “You can have a cookie.”
- The Bible says, “God loves you very much.”
- The angel said to Mary, “You will have a baby. His name will be Jesus. He will be God’s son!”

Bible Truth Activity

When the angel told Mary about the baby Jesus do you think that was good news or bad news? It was good news! Do you think that Mary really had the baby? Yes, she did! The Bible, says, Jesus was born. Let’s all say that together: Jesus was born.

Conclusion

God loves us very much! Who can you tell that God loves them? Many people don’t know that God really loves them. Let’s thank God for loving us. Thank you, God, for loving us and taking care of us. Amen.

If time allows sing verse four of “If You’re Happy and You Know It” from the Unit 4 Song Sheet. Have children hold up the happy face sides of their paper plates while they sing.

Mary and Joseph Take a Trip

The children will learn about Mary and Joseph traveling to Bethlehem where Jesus was born.

Bible Story Text

(Luke 2:1-7)

Materials

For the teacher:

- poster board
- glue
- tape
- 2 craft sticks
- scissors
- washable markers
- laminate or clear contact paper
- angel stick puppet from Unit 4 Lesson 1, Bible Story

Reproducible Pages:

- Page A, 1 copy for the teacher

Preparation

1. Glue the copy of the Reproducible Page A to the poster board and cut out the figures of Mary on a donkey and Joseph.
2. Color the figures and cover them with laminate.
3. Tape craft sticks to the backs of the figures.

Instructions

Show the children the angel stick puppet.

The angel told Mary and Joseph good news! Do you remember what the good news was? Yes, they were going to have a little baby. Before the baby came, though, they had to take a trip. Did you ever go on a trip? Where did you go? Did you go on a vacation? Did you go and see Grandma?

Mary and Joseph got ready to leave on their trip. They packed their clothes and left. How do you think they traveled? Did they have a car? No. Maybe Mary rode on a donkey. Show the stick puppet of Mary on the donkey. The donkey's feet went, "Clop, clop." Can you say that with me? "Clop, clop." Move the Mary on the donkey stick puppet. Joseph walked beside Mary. Show the Joseph stick puppet.

They were traveling to Bethlehem. The King had said that everyone had to go there to be counted. "Clop, clop." It was a long way.

To Bethlehem

Jesus Lesson 2

"Clop, clop." Mary was tired. "Are we there, yet?", she asked.

"Almost," said Joseph, "When we get to Bethlehem we will get a nice room and you can rest." Move both of the stick puppets along.

Soon they came to Bethlehem. Joseph smiled and said, "Look, Mary, there is the inn." An inn is a place where people can spend the night when they travel. "Oh, Joseph, I am so happy we are here. I need to lie down on the bed and take a rest."

Joseph knocked on the door. "Knock, knock." The innkeeper opened the door and said, "I'm sorry, there are no more empty rooms. They are all filled with people spending the night." Joseph was sad. There was no place for place for Mary to rest. He started to walk away. Move the stick puppets slowly. "Why don't we sleep with the animals where it is warm and dry?" said Joseph. That is where Jesus was born.

Say that with me, Jesus was born. That's very good.

Save the Mary and Joseph stick puppets for use during Unit 4 Lesson 3, Bible Story.

Conclusion

Ask the following questions to the children to review the story:

- Who was born? (Jesus)
- Where was he born? (with the animals)
- What is an inn? (a place where people sleep when they travel)
- Where did Mary and Joseph sleep? (with the animals)
- Did Jesus have a crib when he was born? (No, he was put in a manger.)

Let's sing a song about Jesus. Sing "Baby Jesus Was Born" from the Unit 4 Song Sheet.



Packing for a Trip

The children will be reminded of Mary and Joseph's trip to Bethlehem by making toy suitcases.

Materials

For each child:

- 1 piece of light-colored construction paper
- glue stick
- 1 piece of yarn, 5"

For the teacher:

- dark-colored construction paper for handles
- white construction paper
- magazines
- scissors
- marker
- hole punch

Reproducible Pages:

- Page C, 1 copy for the teacher

Preparation

1. Using the magazines, find and cut out pictures of things a child would pack for a trip: clothes, toothbrushes, stuffed animals, etc. Cut five pictures for each child.
2. Fold each child's piece of light-colored construction paper in half.
3. Cut out the handle stencil from the copy of Reproducible Page C.
4. Trace and cut out two handles for each child from the dark-colored construction paper.
5. Cut the white construction paper into 3" x 3" squares. Cut one for each child.
6. Write on the squares, "Packing for a Trip."
7. Cut the white construction paper into 3" x 2" rectangles and punch a hole in one end. These will be the children's name tags.

To Bethlehem

Instructions

1. Give the children each their folded piece of construction paper and two handles.
2. Help the children glue their handles to the inside of their papers, as shown in Figure A.
3. Place the pictures in the center of the table.
4. Let the children choose one picture at a time and glue it to the inside of their "suitcases."
5. Give the children each their white paper squares with "Packing for a trip" written on them. Have them glue these to the outside of their "suitcases."
6. Write each child's name on a name tag.
7. Thread a piece of yarn through the hole in each name tag, and then tie the name tag to one of the handles of each suitcase. See Figure B.

Conclusion

Sing "Going on a Trip" from the Unit 4 Song Sheet. Have the children hold their suitcases and march in the classroom. As you sing about a child, have him look in his "suitcase" and name one object. End the song with a verse using Mary and Joseph's names.

If you need to fill time, sit with the children in a circle and sing "God Helps Me" from the Unit 4 Song Sheet.

Teacher Tips

- During the singing of "Going on a Trip," if the children are unable or unwilling to name an object, have them point it out. You can say it for them. If they don't point out an object, you should choose one for them to keep the song moving along.
- You may use colored paper for the name tags and "Packing for a trip" squares.

Craft

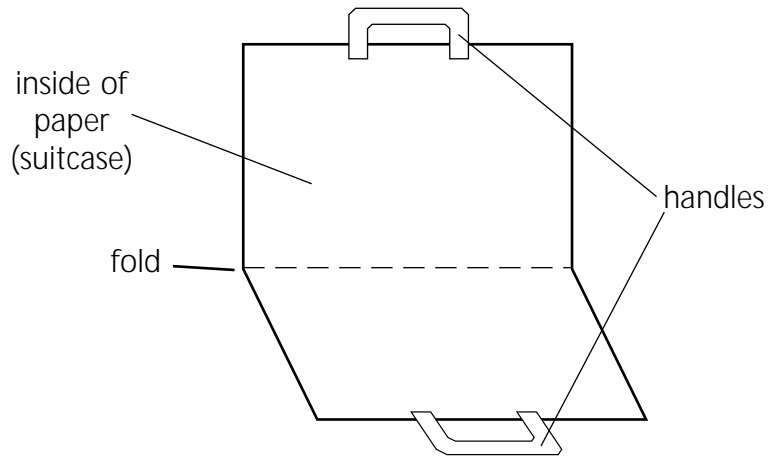

Figure A

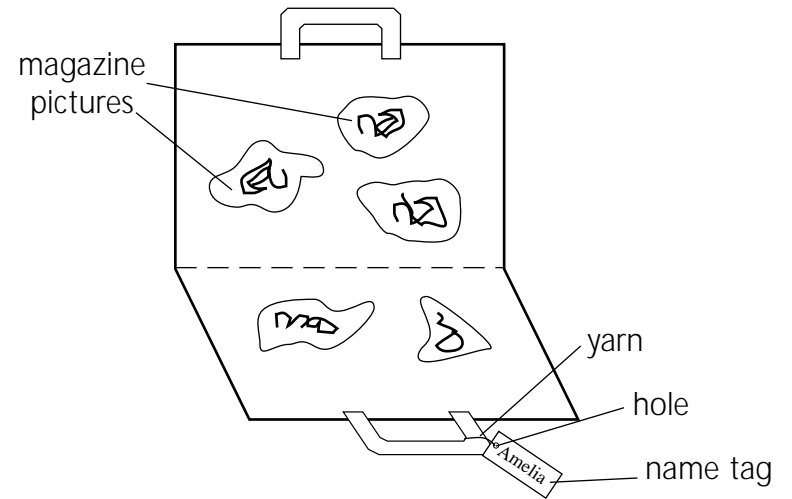
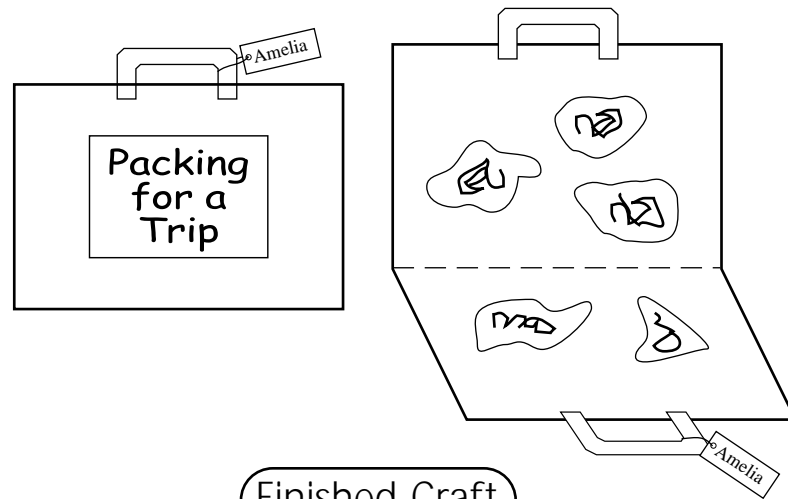

Figure B



Finished Craft





R
e
p
r
o
d
u
c
i
o
n
e

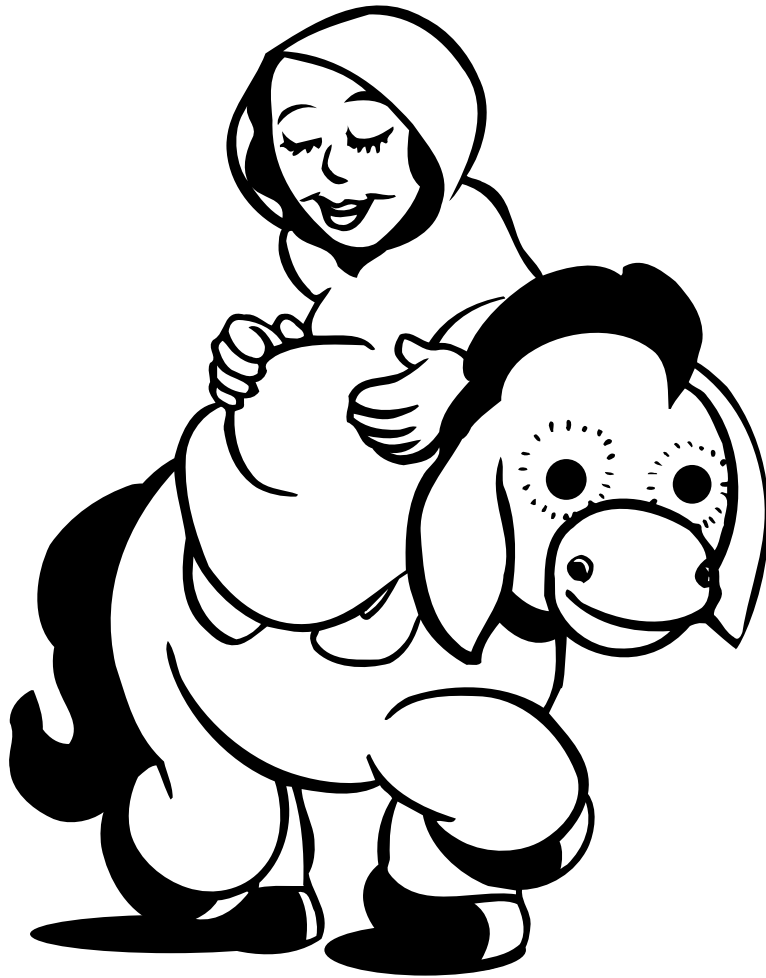

Mary figure



Joseph figure





eye stencil

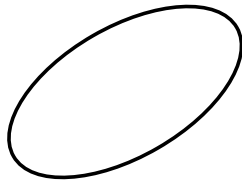

ear stencil

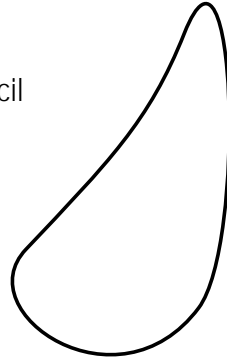

donkey head
stencil

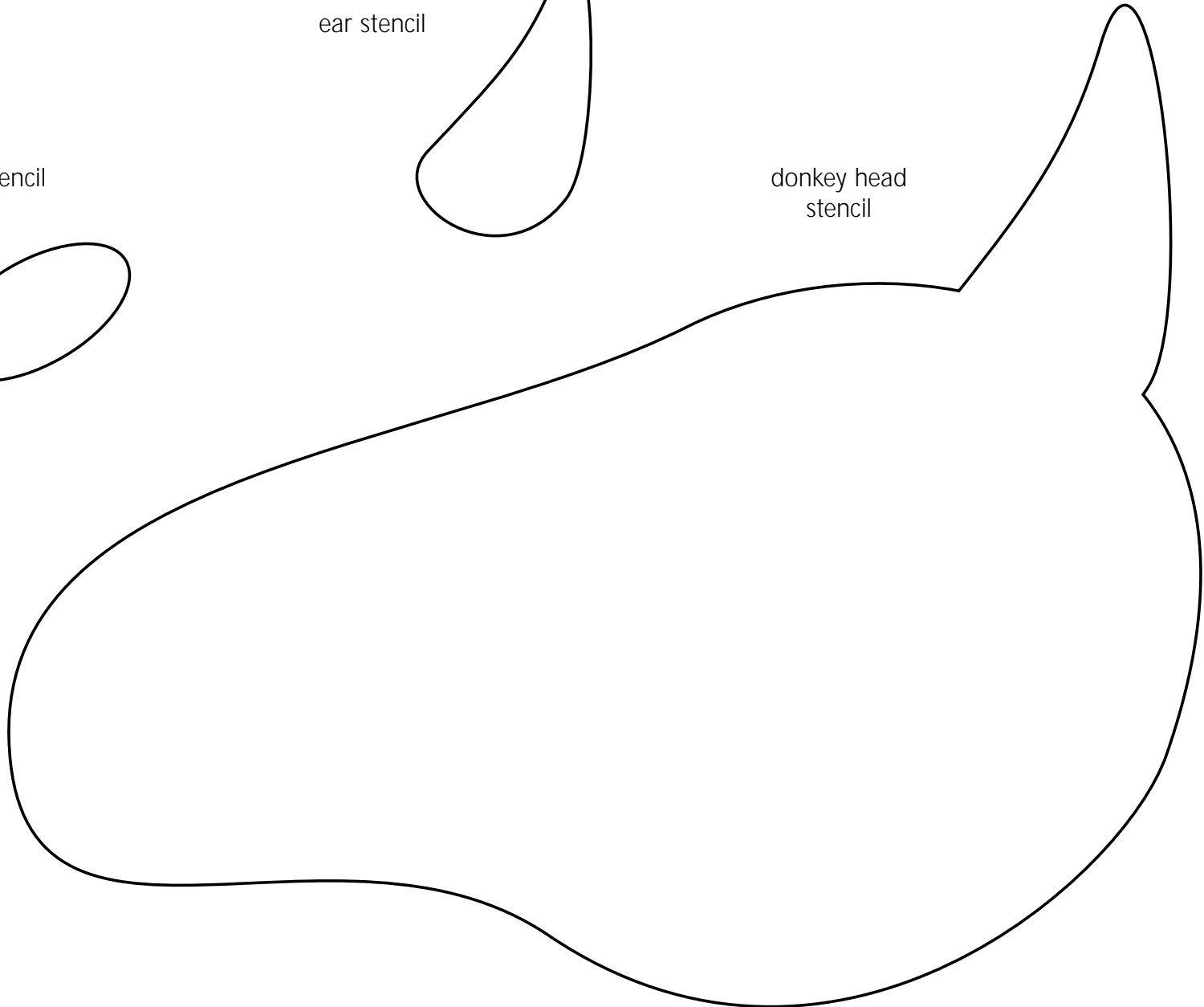



R
e
p
r
o
d
u
c
t
i
o
n
s

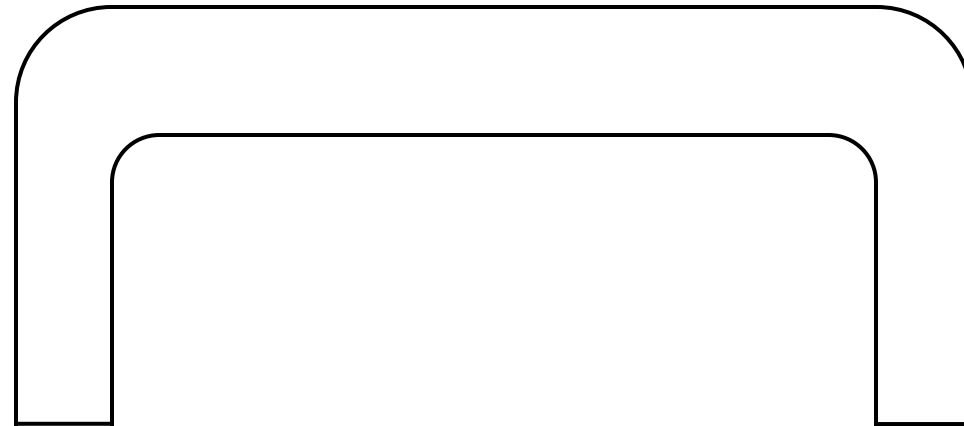

handle stencil

