

Family Feud

Lesson Objectives

- The children will name one thing that separated Jacob and Esau.
- The children will identify selfish and dishonest behavior.
- The children will name two family members whom they will honor.

Lesson Text

Genesis 25 and 27

Scripture Memory Verse

When you do things, do not let selfishness or pride be your guide.

(International Children's Version)

Philippians 2:3

Lesson Plan

Greeting and Registration

Preclass Activity: Meet the Family

Welcome and Singing

Centers:

Bible Story: Family Feud

Craft: Honor Your Parents

Scripture Memory: Memory March

NOTE: Allow time for a snack.

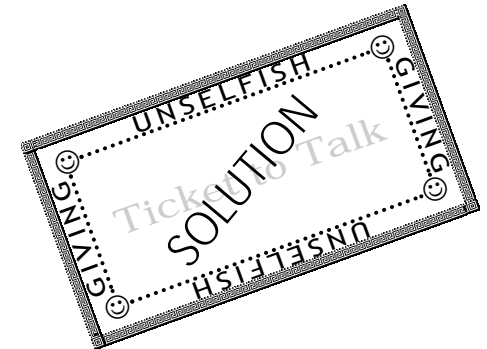
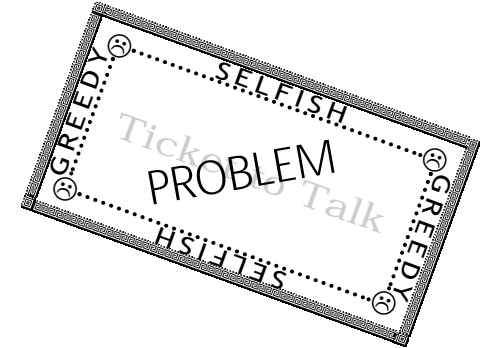

Family Feud

Meet the Family

The children will make puppets of Isaac and Rebekah to use in today's Bible Story.

Materials

For each child:

- 1 plain white paper plate, 6"
- 1 large craft stick
- masking tape
- 1 glue stick
- crayons or markers
- 10 pieces of white or gray yarn, 5" each

For the teacher:

- scissors

Reproducible Pages:

- Page A, 1 copy for each child

Preparation

1. Cut out the puppet faces from the copies of Reproducible Page A for the children. Separate the Isaac faces for the boys and the Rebekah faces for the girls.
2. Prepare the yarn to be used for the puppets' hair.
3. Make a model of the two puppets for the class. Display the models for the children.

Instructions

1. As the children arrive, show them the model puppets you have prepared. Tell the children that you would like them to "meet the family" that they will hear about in their Bible Story today. Explain that the boys will make puppets of Isaac and the girls will make puppets of Rebekah. They will use their puppets to help tell the Bible Story about Isaac and Rebekah's family.
2. Distribute the puppet faces that you prepared, paper plates, crayons, glue sticks, yarn, craft sticks and tape.
3. Direct the children to color their puppet faces first and then glue them to their paper plates.

4. Have the children glue the yarn "hair" onto their puppets.
5. Help the children secure the craft sticks to the paper plates with tape. This will be how they hold their puppets.
6. Help the children label their puppets by writing "Isaac" or "Rebekah" on the craft sticks.
7. Have the children write their names on the backs of their puppets.
8. Collect all the puppets and give them to the Bible Story teacher.

Teacher Tips

- Encourage the children who finish early to make extra puppets for those who might arrive late.

Isaac puppet

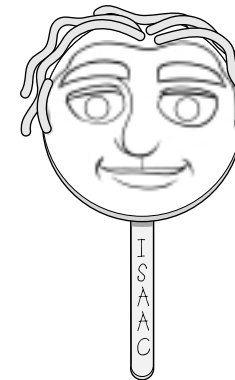

front

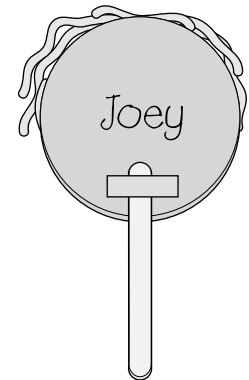

back

B

Family Feud

S

Family Feud

The children will participate in today's Bible Story of Jacob and Esau using the puppets they made in Preclass.

I

Materials

For each child:

- Isaac or Rebekah puppet made in Preclass
- 1 small piece of red paper

T

Preparation

1. Practice telling the story with enthusiasm and expression. Practice telling it two times: once without any pauses, and once allowing time for the children to respond with their puppets and actions.
2. Cut or tear enough red pieces of paper for each child.

B

O

Introducing the Bible Story

As the children arrive, seat them in a circle around you. Have your Bible open to Genesis 25. Introduce today's Bible Story, saying: *Today, our Bible Story comes from chapters 25 and 27 of the book of Genesis. We are going to learn about Isaac's family. Do you remember that Isaac was Abraham's son? Who remembers the name of Isaac's wife? (Rebekah) Rebekah was the special wife that Abraham's servant prayed to find and bring back for Isaac. Isaac and Rebekah had two sons named Jacob and Esau. They were twins! But even though they were twins, they were very different. Esau was the older twin. He was a hairy man. He was a good hunter and liked to do things outdoors. Jacob was a quiet man. He liked to stay close to home. Today, you are going to hear a story about something very serious that happened to these two brothers.*

L

R

E

Y

Explain that you are going to tell this story two times. The first time the children will listen carefully. The second time they will use their puppets and other actions to help you tell the story.

Telling the Story

One day Esau had been out in the field hunting. When he came home, he was very hungry. Jacob was making a delicious stew. Esau was so hungry he thought he would starve to death. Jacob wanted to make a deal with Esau. Jacob told Esau that he would

give him a bowl of the stew if Esau would give him his birthright. A birthright is a special honor and privilege given to the oldest son. It is given as a blessing by the father of the family. Esau agreed. He figured that his birthright was no good to him if he was going to starve to death anyway. Esau promised his birthright to Jacob.

Some time later, when Isaac was old, his eyes had become very weak. Isaac knew that he was old and near death. He asked Esau to go hunt some wild animals and make him a tasty meal. Then Isaac would give Esau his blessing.

Now, Rebekah had been listening to what Isaac said to Esau. She quickly went to Jacob and told him. Rebekah told Jacob to go and kill two goats so that she could make a tasty meal for Isaac. Then, she dressed Jacob in Esau's clothes so that he would smell like Esau. She covered Jacob's arms with goat hair so he would feel hairy like Esau. Rebekah planned to trick Isaac so that Jacob could get the special blessing.

Rebekah told Jacob to give the food to his father and get the special blessing. Jacob did what his mother told him. Jacob went into Isaac's tent and pretended to be Esau. Isaac was confused. He could not see well. He thought he heard Jacob's voice but he felt the hairy arms of Esau. He told his son to come close and kiss him. Isaac smelled the clothes of Esau that Jacob was wearing. So Isaac blessed Jacob thinking it was Esau.

A little later, Esau came home, prepared the food and took it to his father. Esau told his father to eat the food so that he could have his father's blessing. Isaac was surprised. He asked, "Who are you?" Esau told him it was him. Isaac trembled. He told his son that someone else had already come and received the blessing.

Esau let out a loud cry, "Oh! Bless me my father, bless me also!" But there was no special blessing for Esau. Esau wept bitterly. Esau was very angry. He said, "After my father dies, I will kill Jacob." Rebekah heard this and said to Jacob, "Your brother wants to kill you. You must run away to Haran and stay with my brother." And so he did.

Retelling the Story

Distribute the children's puppets that they made during Preclass and the red pieces of paper. Tell the boys to hold up their puppets each



B
S
I
T
B
O
L
R
E
Y

Family Feud

time they hear you say "Isaac." Tell the girls to hold up their puppets each time they hear you say "Rebekah." Tell all the children to hold up their piece of red paper each time they hear you say "Esau" because he looked red when he was born. Each time they hear you say "Jacob" they will hold up their finger to their mouth to make the "quiet" signal because Jacob was a quiet man. Tell the children to listen carefully as you tell the story again.

Share and Tell

Ask the children how they feel about this story. Ask them if they think Rebekah did the right thing to trick Isaac. Ask them if Jacob did the right thing to lie to his father. Explain that Rebekah and Jacob were selfish and dishonest. They wanted something that belonged to Esau. Because of what happened, Jacob and Esau were separated. It was a very sad time for this family. Tell the children that any time a person lies or is selfish, someone else gets hurt. God wants us to be honest and unselfish. He wants us to think of other people's needs first.

Ask the children to share the name of one person in their family that they want to tell the story of Jacob and Esau to. Remind them that God wants us to tell others so they won't make the same mistakes as this family. Close with a prayer for the children to be honest and unselfish this week in their family.

Teacher Tips

- Pray that you will help the children see the serious nature of Jacob and Rebekah's selfishness and dishonesty. Let them see your heart to please God.

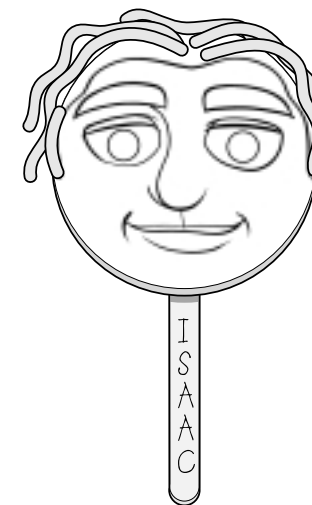

C
●
R
●
A
●
F
●
T
●
●
●

Family Feud

Honor Your Parents

The children will make a medal of honor for their parents.

Materials

For each child:

- crayons or markers
- 1 piece of blue ribbon, 1½" x 30"
- 1 piece of red ribbon, 1½" x 30"
- 2 pieces of cardboard or poster board, 4" x 4"
- 2 pieces of aluminum foil, 5" x 5"
- 1 glue stick
- invisible tape

For the teacher:

- scissors
- hole punch

Reproducible Pages:

- Page B, 1 copy for each child

Preparation

1. Prepare a sample of the two medals to show to the children.
2. Prepare the ribbon, cardboard, and foil for the children.
3. On each piece of cardboard, punch a double hole in one corner, ½ inch from the edge, as shown in Figure A.
4. Cut out the "medals" from copies of Reproducible Page B for the children.

Instructions

NOTE: In this activity, as always, be sensitive to the children who do not live with both parents. They should feel welcome to make a medal for another caretaker (i.e., grandparent, aunt, uncle or step-parent). Do not allow the children to make fun of each other because of their family situations.

1. Introduce today's craft by saying: *In our Bible Story today, we learned about the family of Isaac and Rebekah. We learned that Jacob did not honor his brother and he lied to his father so that he could have his brother's special blessing. Because of what happened, Jacob and Esau were separated. The Bible says that we should honor our father and mother. This is a command of God. What are some ways we can show honor to our mothers*



and fathers? (Take a few responses.) In the Olympics, athletes are honored with a special medal. In the army, soldiers are honored with special medals. These people are honored because they have accomplished something and showed great skill or courage. We should honor our parents because they have done many things for us that deserve honor and also because God says that we should. Show the children the medals that you have prepared. Tell them that they each will make one for their mother and father.

2. Distribute the crayons and the medals that you prepared for the children. Direct them to color and decorate the medals and write the person they wish to honor in the spaces provided.
3. As they finish coloring, distribute the glue sticks, tape, cardboard and foil that you prepared.
4. Show the children how to cover the cardboard with the foil and secure it with tape on the back. Help the children make a hole in the foil over the hole that you punched in the cardboard. See Figure B.
5. Have the children glue the medals that they have colored onto the cardboard pieces with the glue sticks, as shown in Figure C.
6. Distribute the ribbon. Help the children to thread their pieces through the holes and tie them as shown.

Conclusion

Let the children show their medals to each other. Close with a prayer thanking God for parents—and those who take care of us. Ask God to help the children to show honor to their parents as God commands.

Teacher Tips

- You may want to arrange for a special ceremony for the children to present their medals of honor.

Family Feud

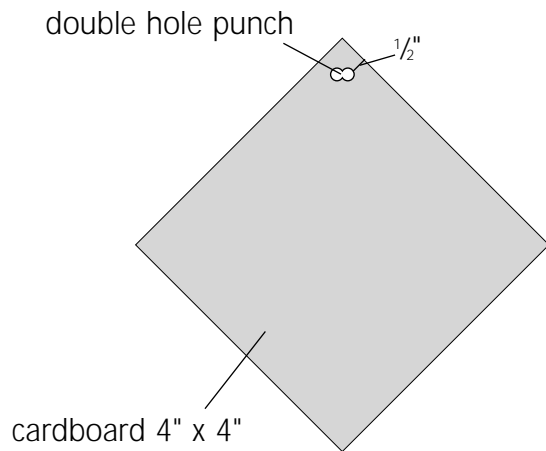

Figure A

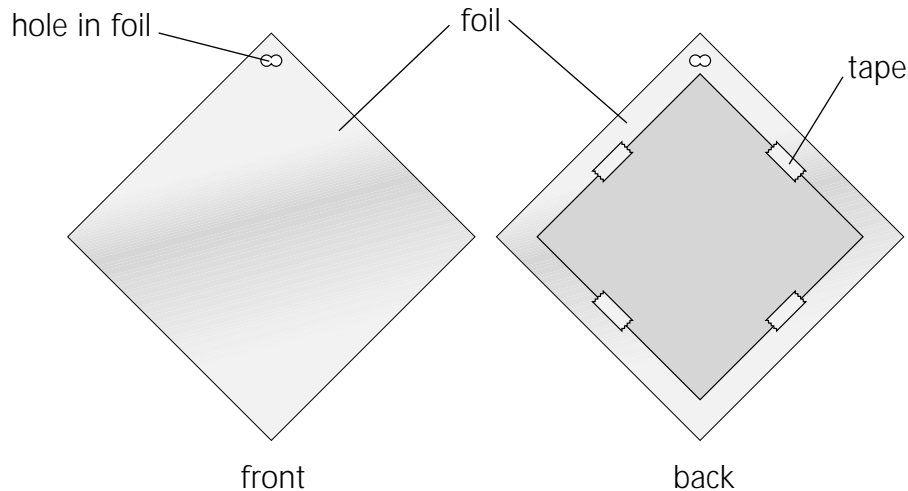

Figure B

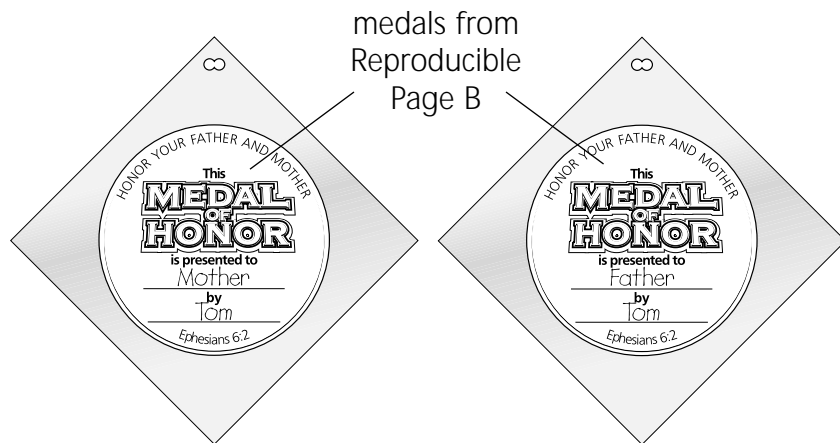

Figure C



Finished Craft

SCR
IPT
URE
MEM
ORY

Family Feud

Memory March

The children will learn the Scripture Memory Verse by repetition and marching in rhythm to the scripture.

Scripture Memory Verse

When you do things, do not let selfishness or pride be your guide. (ICV)

Philippians 2:3

Materials

For the teacher:

- large writing surface

Preparation

Print the Scripture Memory Verse on a large writing surface.

Instructions

1. Read the Scripture Memory Verse to the children using the verse on the back of this card.
2. Remind the children of today's Bible Story: *In our Bible Story, we learned that Jacob and Rebekah were selfish and dishonest. Jacob wanted his brother's special blessing. Rebekah wanted Jacob to lie to his father and get the blessing. Because of selfishness and dishonesty, Esau was very angry and very sad. Isaac was upset that he had been tricked, and Jacob had to go away so that his brother would not kill him. It is a very serious thing when we are selfish and do not tell the truth.*
3. Read the verse together as a group two more times.
4. Invite the children to stand up and form a line where they stand side by side. Tell them that they will march in place and say the verse as they march. Practice marching in place beginning with the left foot. Lead the children saying: *Left, right, left, right, left, right, etc.*
5. Now say the verse with the children marching to each word or syllable. Have them end saying the reference. Have them stop and salute. Repeat this three times, each time marching to a faster or slower pace.

6. Invite two children to step forward and say the verse together, marching in place. Continue until all the children have had a chance to do it with a partner.
7. Have the children sit in a circle. Ask if anyone would like to say the verse alone to the group. Give everyone an opportunity to try.

Conclusion

Ask the children to each say one way that they can be unselfish this week. Close with a prayer for the children to be unselfish this week with their family and their friends.

Teacher Tips

- Think of creative marching styles or techniques. Bring in a drum or tambourine to help keep the rhythm and make the activity more interesting.



When you do things,
do not let selfishness or
pride be your guide. (ICV)

Philippians 2:3

Lesson Objectives

- The children will name one thing that separated Jacob and Esau.
- The children will identify selfish and dishonest behavior.
- The children will name two family members whom they will honor.

Lesson Text

Genesis 25 and 27

Scripture Memory Verse

When you do things, do not let selfishness or pride be your guide. (ICV)

Philippians 2:3

Lesson Plan

Greeting and Registration

Preclass Activity: My Two Sons

Welcome and Singing

Centers:

Life Application: What to Do?

Game: All in the Family

Bible Skills: Book Reports

NOTE: Allow time for a snack.



pre class

ACTIVITY

My Two Sons

The children will review this week's Bible Story with this worksheet and word search.

Materials

For each child:

- 1 pencil
- markers

Reproducible Pages:

- Page C, 1 copy for each child

Preparation

Complete a copy of Reproducible Page C to show the children.

Instructions

1. As the children arrive, direct them to the copies of Reproducible Page C. Explain that this is a review of this week's Bible Story. Encourage the children to work together. Pair the children who have not heard the Bible Story with those who did.
2. Be careful to help young readers with the words on this page.
3. When the children have finished, encourage them to draw a picture of one of the people from this week's Bible Story on the back of their page.

Answer Key

- (1.) T (2.) F (3.) T (4.) F (5.) T
(6.) T (7.) F

Teacher Tips

- Ask the children who they shared with this week about Jacob and Esau.

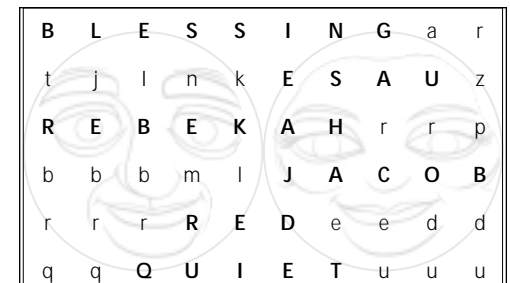

Find and circle the following words in the Word Search above:

BLESSING
REBEKAH

ESAU
RED

JACOB
QUIET

What to Do?

The children will listen to various scenarios that depict selfishness and dishonesty. The children will complete the scenarios by suggesting appropriate solutions.

Materials

For the teacher:

- scissors

Reproducible Pages:

- Page D, 1 copy for each child

Preparation

1. Practice presenting the different scenarios with expression.
2. Cut out the Tickets to Talk from the copies of Reproducible Page D for the children.

Reviewing the Bible Story

In our Bible Story this week we learned about a family that had some problems with selfishness and dishonesty. Who can tell me what selfishness is? (Only wanting something for yourself; not caring about others, etc.) What does a selfish person do? (Take a few responses.) What is the opposite of selfish? (unselfish, generous, thoughtful) Who can tell me what dishonesty is? (Not telling the truth; only telling part of the truth) What does a dishonest person do? (Take a few responses.) What is the opposite of dishonesty? (honesty, truth)

I am going to read some things from our Bible Story and I want you to say if it was something selfish or dishonest.

- Jacob made Esau trade his birthright for some stew. (selfish)
- Rebekah told Jacob to dress up like his brother and trick Isaac. (dishonest)
- Jacob dressed up like Esau and tricked his father. (dishonest)
- Jacob took Esau's special blessing. (selfish)

Family Feud

Making Connections

Now, I am going to tell you about some problems. I want you to listen carefully. After each one, I will ask you to choose the word that will solve the problem and hold it up. Distribute the Tickets to Talk that you prepared for the children. Tell the children that they can only talk if they first hold up their ticket and are called on. If not, they will not be called on. After each situation, you will ask them to choose the problem and the solution. Children should be prepared to explain their answer.

Your friend has a baseball card that you want. It is the only one left in the series that you need. You say that he should give it to you. If he doesn't, you won't be his friend anymore. What is the problem? (selfishness) Tell me how to solve it.

You are at your friend's house getting ready to go to the park. Your friend's mother tells her to put her clothes away before she can go out. She tells her mother that she put her clothes away. You know she is not telling the truth. What is the problem? (dishonesty) Tell me how to solve it.

You are at school and everyone is getting in line for lunch. You see Mary drop a dollar on the floor. You think, "I could use that dollar to buy some candy after school." What is the problem? (selfishness) Tell me how to solve it.

Your friends come over to your house for your birthday party. Your mother made your favorite cake. She has just enough for everyone. You tell her you did not have a piece so that you can have another one. That means someone else won't get a piece. What is the problem? (selfishness and dishonesty) Tell me how to solve it.

Conclusion

Close with a prayer thanking God for showing us the right way to do things.

Teacher Tips

- Pray for the children to make personal applications to these situations.

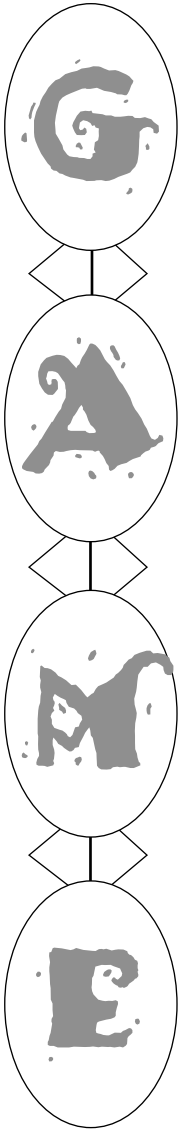

All in the Family

The children review this week's Bible Story in this fun, passing game.

Materials

For the teacher:

- 1 small bean bag
- large writing surface

Preparation

On the large writing surface, print the names of the Bible Story characters: Rebekah, Isaac, Jacob and Esau.

Instructions

1. Introduce today's game: *In our Bible Story about Jacob and Esau, we saw how selfishness and dishonesty hurt their family. In our game, you will have to think about the story and be able to match the Bible character to the action I will say.*
2. Explain that this game is like "hot potato." Have the children stand in a circle. You read a question from the list on the back of this card and then toss the bean bag to any child in the circle. If the child with the bean bag knows the answer, he may say it. If he does not know it, he quickly passes it to the next child who can answer or pass it on, and so on. After the bean bag has gone all the way around, you will state the correct answer.
3. The object of the game is to see how quickly the children can name the character and toss the bag.
4. After you have played the game this way, try playing it with the children naming one of the characters and tossing the "hot potato" to the next child. That child has to state what the character did, then name another character, toss it to the next child and so on.

Family Feud

Conclusion

Close with a prayer asking God to help the children honor and love their families.

Teacher Tips

- Encourage the children for their participation, especially those who are new or visiting. Always encourage children who heard the Bible Story to reach out to children who did not so that everyone feels successful.



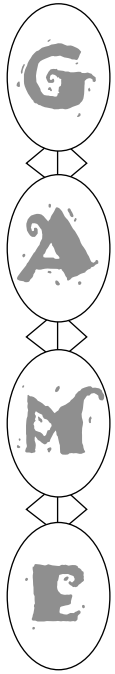

Questions for All in the Family

1. Who was so hungry he said he was starving? (Esau)
2. Who liked to hunt? (Esau)
3. Who was Esau's brother? (Jacob)
4. Who listened to the conversation between Isaac and Esau? (Rebekah)
5. Who had weak eyes when he was old? (Isaac)
6. Who was hairy and liked the outdoors? (Esau)
7. Who was quiet and liked to stay home? (Jacob)
8. Who tricked his father into getting his brother's blessing? (Jacob)
9. Who threatened to kill his brother? (Esau)
10. Who ran away from home? (Jacob)

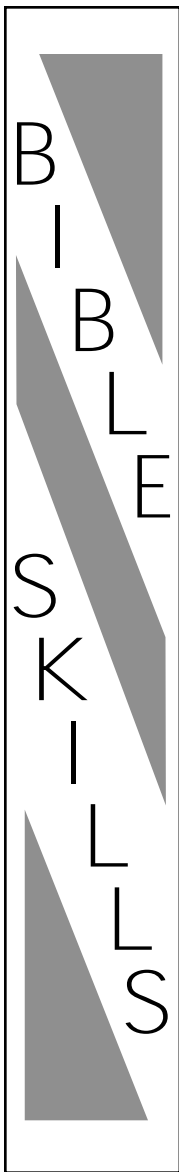

Book Reports

(Books of the Major Prophets)

The children will learn and review one idea for each Old Testament book by playing a version of a popular family game show.

Materials

For the teacher:

- a bell or buzzer that the children can hit with their hands
- large writing surface
- score pad and pencil

Preparation

1. Using the list on the back of this card as a guide, write the book names and main ideas on the large writing surface where all the children can see them. Be prepared to cover the main ideas later in the activity.
2. Practice playing this game with friends or family.

Instructions

1. Remind the children that they are learning one important idea about each book of the Old Testament.
2. Using the list you prepared on the large writing surface, present these new books and ideas to the children: *Isaiah told the people that Jesus is coming. Jeremiah teaches us that people forgot God. Lamentations means crying for God's people. Ezekiel shows God's glory. Daniel helped people understand their dreams.*
3. Do a quick review of the books from Genesis to Song of Songs, having the children repeat after you.
4. Divide the group into two teams. Place the bell on a table between the two teams.
5. The first two players step up to the bell. To determine the team that will begin, you will read one "main idea" from the list on the back of this card and the children listen carefully. The first player to hit the bell and give the correct book, wins the right to go first.

Family Feud

6. The first round is played with the large writing surface in view of the children. You will read one main idea from the list at a time. Teams take turns naming the correct Old Testament book that matches it. In Round One, each correct answer is worth five points.
7. When a member of the playing team makes an error, the opposing team may try to answer.
8. Round One is finished when you have finished going through the Main Idea list one time.
9. For Round Two, cover the main ideas on the large writing surface so that the children can only see the book names. The game is played as before. Round Two is finished after you have completed the Main Idea list a second time. Each correct answer is now worth ten points.
10. The team with the most number of points wins. All children should shake hands in a spirit of good sportsmanship.

Conclusion

Close with a prayer thanking God for the message of the prophets to help us know him better.

Teacher Tips

- Set a great example! Make sure you are familiar with the main ideas of each book.

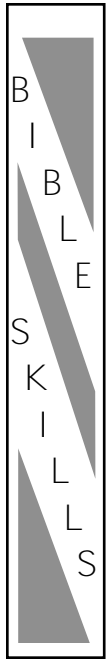

Old Testament Books and Main Ideas List

Book

Genesis

Exodus

Leviticus

Numbers

Deuteronomy

Joshua

Judges

Ruth

1 & 2 Samuel

1 & 2 Kings

1 & 2 Chronicles

Ezra

Main Idea

The Beginning

Exit Egypt

Learn the Law

People Count!

Love the LORD

Entering the Promised Land

The LORD's Leaders

Devoted to You

King David and Son

Ups and Downs

Prophets, Kings, Captivity

Back to Build

Book

Nehemiah

Esther

Job

Psalms

Proverbs

Ecclesiastes

Song of Songs

Isaiah

Jeremiah

Lamentations

Ezekiel

Daniel

Main Idea

The Wall

Brave Queen

Faithful in Hard Times

Song Book

Wise Words

Meaning of Life

Love Song

Jesus Is Coming

People Forgot God

Crying for God's People

See God's Glory

Dreams and Visions



Core/Preclass
1 copy for each child

R
E
P
R
O
D
U
C
I
B
L
E

PAGE

A



Isaac puppet face



Rebekah puppet face



Core/Craft
1 copy for each child

R
E
P
R
O
D
U
C
I
B
L
E
P
A
G
E
B



Supplement/Preclass
1 copy for each child

My Two Sons

At the end of each line, write a "T" if it is True and "F" if it is False.

1. Esau liked to hunt and be outside. _____
2. Jacob was not quiet and did not like to stay at home. _____
3. Jacob made a delicious stew. _____
4. Esau traded his bicycle for some stew. _____
5. Isaac was very old and his eyes were weak. _____
6. Jacob tricked Isaac to get his brother's blessing. _____
7. Esau was very happy that Jacob got the blessing. _____

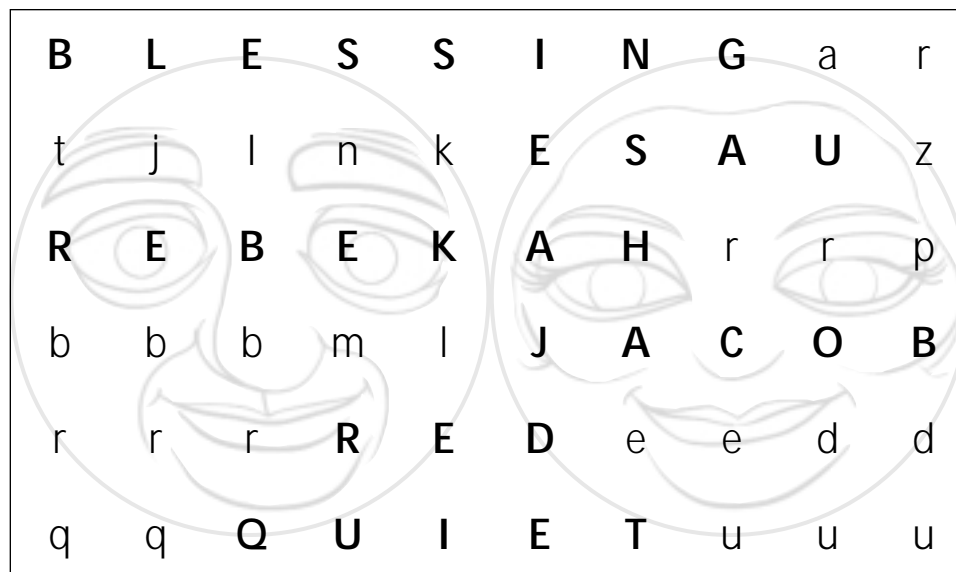

Find and circle the following words in the Word Search above:

BLESSING
REBEKAH

ESAU
RED

JACOB
QUIET

R
E
P
R
O
D
U
C
I
B
L
E
E
C

PAGE

C



Supplement/Life Application

1 copy for each child

SELFISH

GREEDY

PROBLEM

GREEDY

SELFISH

UNSELFISH

GIVING

SOLUTION

GIVING

UNSELFISH

DISHONEST

LIE

PROBLEM

LIE

DISHONEST

HONEST

TRUTH

SOLUTION

TRUTH

HONEST

