

Devotion to God

God's Family
Lesson 3

Lesson Objectives

- The children will role play ways that Abraham, his servant, Rebekah and Isaac showed devotion to God.
- The children will describe one way that they can show devotion to God.
- The children will name three ways their families can serve God.

Lesson Text

Genesis 24

Scripture Memory Verse

Here is Rebekah; take her and go, and let her become the wife of your master's son, as the LORD has directed.

Genesis 24:51

Lesson Plan

Greeting and Registration

Preclass Activity: Family Servers

Welcome and Singing

Centers:

Bible Story: A Family Devoted to God

Craft: Fruit Baskets

Scripture Memory: Tag and Tell

NOTE: Allow time for a snack.



Devotion to God

Family Servers

The children will identify ways in which they and their families can serve God, as they make a cube with four ideas.

Materials

For each child:

- crayons or colored pencils
- invisible tape

For the teacher:

- scissors

Reproducible Pages:

- Page A, 1 copy for each child

Preparation

1. Make a sample cube as a model for the children.
2. Cut out the cube forms from the copies of Reproducible Page A.

Instructions

1. As the children arrive, show them your model and explain that each side of the cube suggests a different way that they and their families can serve God.
2. Distribute the crayons and cube forms that you prepared for the children.
3. Direct the children to color the pictures and write their names in the spaces provided.
4. Help the children to fold the cube form on the dashed lines to make the cube. Help them to tape the edges together to form the cube.
5. As the children are working, circulate among the children and talk about different ways your family has served God.

Teacher Tips

- Be sensitive to some children whose parents are not both disciples and who may not feel that their families can serve God in the ways described. Encourage all the children that they can serve God by helping their families.



B Devotion to God

S

A Family Devoted to God

The children will listen to and participate in the story of Abraham getting a wife for Isaac.

Materials

For the teacher:

- paper cup
- an invitation (may be new or used)
- scarf
- man's tie
- large bag or cloth sack
- large writing surface

Preparation

1. Read Genesis 24.
2. Place the cup, invitation, scarf and tie in the large bag. Practice telling the story using the props.
3. On the large writing surface, write: Promise, Journey and Prayer, Invitation, Wedding—leaving space between each word.

Introducing the Story

Seat the children in a circle or semi-circle where they can all see you. Introduce today's Bible story by saying: *Today we are going to learn about a family that was devoted to God. Raise your hand if you have heard the word "devoted." What do you think devoted means? (Accept a few responses.) To be devoted to someone or something means to be totally committed and loyal to that someone or something. Today you are going to hear about some people whose families were devoted to God.*

Telling the Story

Have your Bible open to Genesis 24, telling the children: *Today's Bible Story comes from Genesis 24 in the Old Testament. The story has four parts. Each part has a special name. Those four names are written here. Read the words on the large writing surface aloud and have the children repeat them after you. Tell the children that you have brought some special things to help you tell this story and you will need their help as well.*

The Promise (Genesis 24:1-4)

When Abraham was old, he wanted to get a good wife for Isaac, as God commanded. So he called his servant to him and made the servant promise that he would return to Abraham's homeland and find a wife for Isaac from among his own people.

- *Now, I want each of you to pretend that I am Abraham and you are my servant. I will come to you and ask you to promise to return to my country and find my son Isaac a good wife.* Line up the children and ask each one: *Do you promise to go to my country and find my son Isaac a good wife?* Have the children shake your hand and say: *"Yes, I promise to go to your country and find your son Isaac a good wife."* When they are finished, direct the children back to their seats to begin part two.

The Journey and the Prayer (Genesis 24:10-14)

The servant obeyed. He traveled to Abraham's homeland. He stopped at a well outside a town to water his camels. He prayed that God would help him know which woman was to be the wife of Isaac. He prayed that it would be the one who would give him a drink of water, and water for his camels also.

- *Now, I want each of you to pretend that you are the servant. You have traveled on a long journey and now you will pray to ask God for help.* Line up the children behind you and march around in a circle three times. Stop marching and have them repeat after you as you get on your knees and bow your head: *Dear God, Please help me today as I look for a wife for my master's son Isaac. I pray that you will show me exactly who the right one will be. I pray that when I ask her for a drink of water, she will offer to give me water and my camels too. Amen.* Have the children return to the circle to begin part three.

The Invitation (Genesis 24:17-25)

Before the servant ended his prayer, Rebekah came to the well. Then the servant asked her for a drink. She was eager to serve him and offered to give water to his ten thirsty camels. This was hard work for Rebekah. The servant gave her some beautiful gifts and asked her about her family. Rebekah told him about her father and

I

T

B

O

L

R

E

Y



Devotion to God

then she invited the servant to her home. The servant knew God had answered his prayer.

- Now, I want all of you to pretend that you are Rebekah and I am the servant. I will come to each of you and ask you for a drink. You will give me a drink and a drink for my camels. Then you will invite me to your home. Line up the children. Hand the cup and invitation to the first child. Ask the child for a drink. Have the child offer you (and your imaginary camels) a drink and then give you an invitation. Have the child pass the cup and invitation to the next child. Continue until all the children have had a chance. Have the children return to the circle to begin part four.

The Wedding (Genesis 24:57-67)

The servant knew God had answered his prayer. He told Rebekah's father everything. Her father said she could go back with the servant and marry Isaac. Rebekah was eager to go with the servant. She and her servants rode on camels back to Isaac's home. As they reached the place, Rebekah saw a man from far away. When she learned that it was Isaac, she covered her face with her veil. The servant told Isaac all he had done. Isaac married Rebekah. She became his wife and he loved her.

- Now I want the boys to pretend to be Isaac and the girls to pretend to be Rebekah. Have them form two lines with an aisle between. Give the first boy in line the tie and the first girl the scarf to put on her head as a veil. Have them walk down the "aisle" to the end of the line, passing the tie and scarf onto the next children. Repeat until all the children have had a chance to go. NOTE: If walking down the aisle together makes the boys and girls feel too silly, have the boy walk down first, followed by the girl.

Share and Tell

Bring the children back into the circle. Remind them that in this Bible story, there were two families who were devoted—or totally committed—to God: Isaac's family and Rebekah's family. Encourage the children that they can be like Isaac and Rebekah. Ask each child to say who they will share today's Bible story with this week. Close with a prayer for the children to be devoted to God and to their families.

Teacher Tips

- Practice telling this story a few times before class. Don't hold back when it comes to role playing the characters!

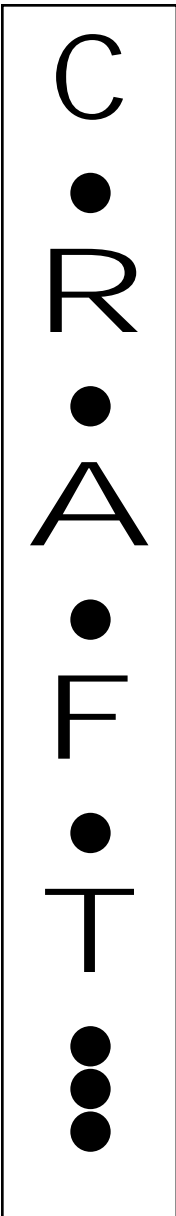

Devotion to God

Fruit Baskets

The children will reflect on ways in which Abraham's family served God as they make a special basket to hold ideas they can say and do when others visit their home.

Materials

For each child:

- 1 regular paper plate, 9" diameter (not plastic, styrofoam or heavy paper)
- 4 pieces of pipe cleaner, 3" each
- 1 pipe cleaner, 1'
- 1 glue stick
- crayons
- colorful stickers of fruit (optional)

For the teacher:

- scissors
- hole punch

Reproducible Pages:

- Page B, 1 copy for each child

Preparation

1. Draw fold lines on each child's plate and cut out the four small corners, as shown in Figure A.
2. Punch eight holes on each plate, each hole about 1/2 inch from the side of the cuts you have made. See Figure A.
3. Make a sample Fruit Basket.
4. Cut out the fruit-shaped pictures from copies of Reproducible Page B for each child.

Instructions

1. Introduce today's craft, saying: *In our Bible Story, we saw how Abraham's family served God. What are some ways your family can serve God? Today we will make special baskets full of pictures of fruit. On each piece of fruit there is an idea for a kind thing we can say or do when other people come to our homes. This is one way we can bear fruit for God.*
2. Distribute the plates that you prepared for the children.

3. Show the children how to fold up the four edges of the plate along the fold lines, as shown in Figure B.
4. Help the children make corners of the basket by bringing together two holes at one of the cut wedges. Help them feed one of the short pieces of pipe cleaner through the holes and twist together. Help them do this for the other three corners. See Figure C.
5. Distribute the long pipe cleaner to each child. Help them tie the ends of this pipe cleaner to opposite corners of the basket, making a handle, as shown.
6. The children can decorate their baskets with crayons and stickers. Have them color the fruit pictures and place them in their baskets.

Conclusion

Encourage the children about their baskets. Remind them that God wants us to bear fruit and this is one way we can do that. Each time they show hospitality, they are serving God. Close with a prayer. Thank God for the children and ask him to help them love to serve others.

Teacher Tips

- Bring in a copy of *The Fine Art of Hospitality*, edited by Sheila Jones from DPI, to show the children. Tell them about ways that you and your family serve others.

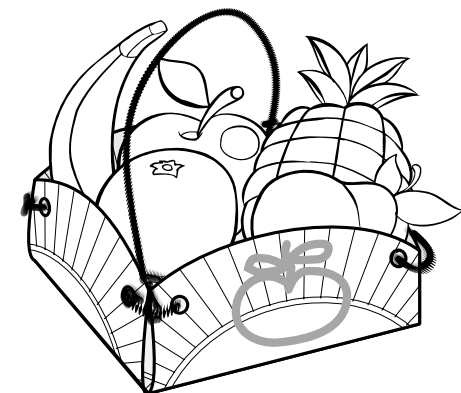

Devotion to God

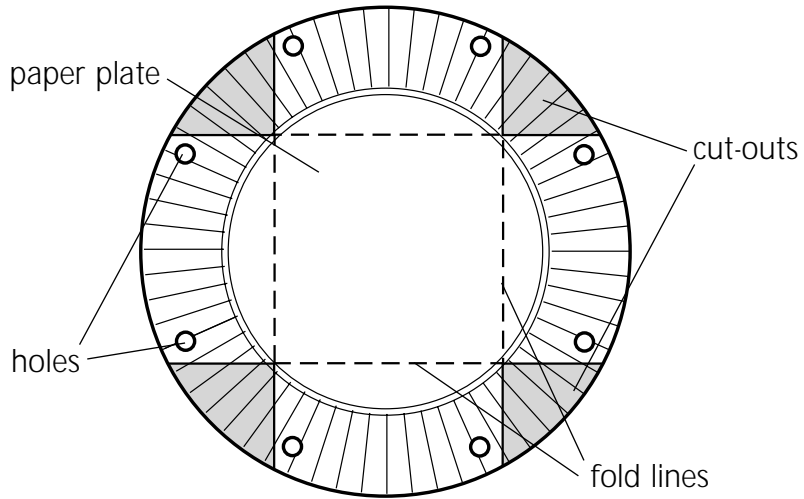

Figure A

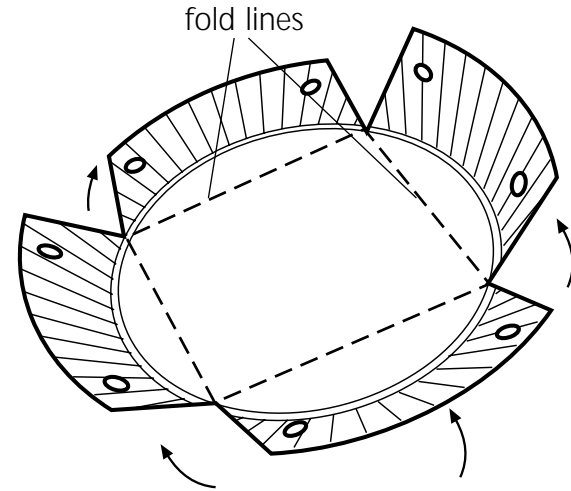

Figure B

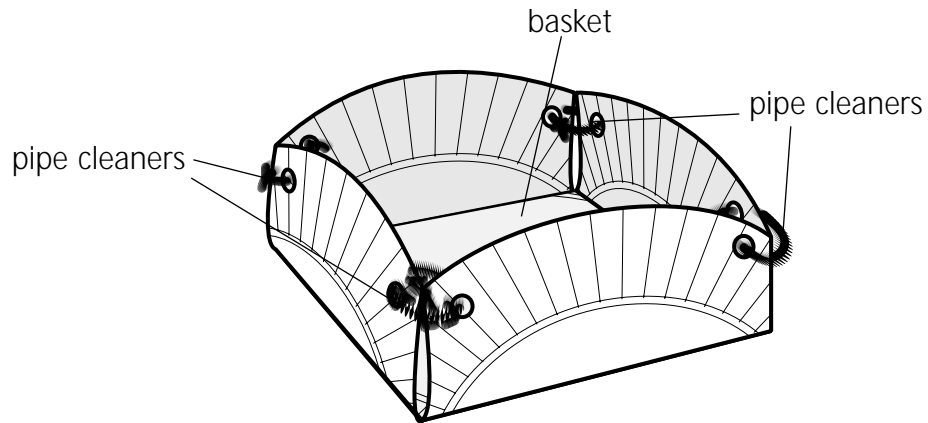

Figure C

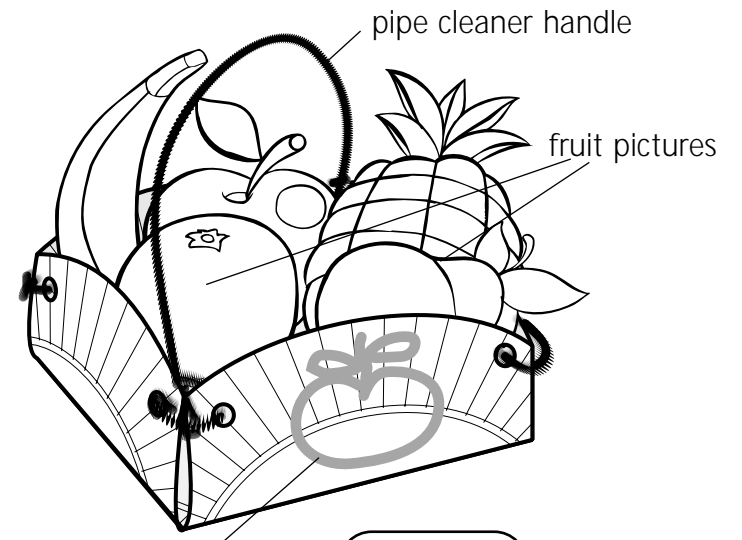

Figure D

SCR
IPT
URE
MEM
ORY

Devotion to God

Tag and Tell

The children will learn the Scripture Memory Verse as they repeat it during the Tag and Tell relay.

Scripture Memory Verse

Here is Rebekah; take her and go, and let her become the wife of your master's son, as the LORD has directed.

Genesis 24:51

Materials

For the teacher:

- 2 large poster boards
- 1 black marker

Preparation

1. Neatly print the phrases of the Scripture Memory Verse on both poster boards as follows:

Here is Rebekah;
take her and go,
and let her become
the wife of your master's son,
as the Lord has directed.
Genesis 24:51

2. Hang the two poster boards of the Scripture Memory Verse up on the same wall about three feet apart.

Instructions

1. As the children arrive, show them one of the memory verses on the wall. Read it to them phrase by phrase. Have them read it with you. Then, have them whisper it with you. Finally, (if appropriate) have them shout it with you. Repeat until the children are familiar with the verse.
2. Divide the group into two teams for this relay. The first child in both lines will walk up to the wall, tag the poster, say the first phrase and walk back and tag the next child in line. The next person will walk up and tag the poster and say the second phrase, then walk back and tag the next person, and so on.
3. The first team to finish will say the entire verse all together to the class.

Conclusion

Take down the poster boards and call on volunteers to say the verse from memory. Close with a prayer thanking God for Rebekah and her family's devotion to God.

Teacher Tips

- Do not let the children make others feel unwanted when dividing into teams.



Devotion to God

SCR
IPT
URE
MEM
ORY

Here is Rebekah;
take her and go,
and let her become
the wife of your master's son,
as the LORD has directed.

Genesis 24:51



Lesson Objectives

- The children will role play ways that Abraham, his servant, Rebekah and Isaac showed devotion to God.
- The children will describe one way that they can show devotion to God.
- The children will name three ways their families can serve God.

Lesson Text

Genesis 24

Scripture Memory Verse

Here is Rebekah; take her and go, and let her become the wife of your master's son, as the LORD has directed.

Genesis 24:51

Lesson Plan

Greeting and Registration

Preclass Activity: Family Value Pack

Welcome and Singing

Centers:

Life Application: Family Service Station

Game: Service with a Smile

Bible Skills: Book Reports

NOTE: Allow time for a snack.



pre
class

ACTIVITY

Family Value Pack

The children will make and decorate a set of coupons that will describe several ways they and their families can serve others.

Materials

For each child:

- crayons
- 1 glue stick
- 6 index cards, 3" x 5"
- 1 envelope, at least 6" long

For the teacher:

- scissors

Reproducible Pages:

- Page C, 1 copy for each child

Preparation

1. Make a sample of a Family Value Pack to show the children.
2. Cut out the "coupons" from copies of Reproducible Page C for the children.

3. On each child's envelope, neatly print: _____'s Family Value Pack.

Instructions

1. As the children arrive, show them the sample Family Value Pack that you made. Explain that they will make and decorate coupons that will help them and their families to serve God.
2. Distribute the children's sets of coupons that you prepared and the crayons. Have the children color and decorate the coupons.
3. Distribute the index cards, glue sticks and envelopes. Have them glue the coupons to the index cards and then place them in the envelope. Show them where to write their names—in the space you prepared.

Teacher Tips

- Be sensitive to some children whose parents are not both disciples and who may not feel that their families can serve God in the ways described. Encourage all the children that they can serve God by helping their families.

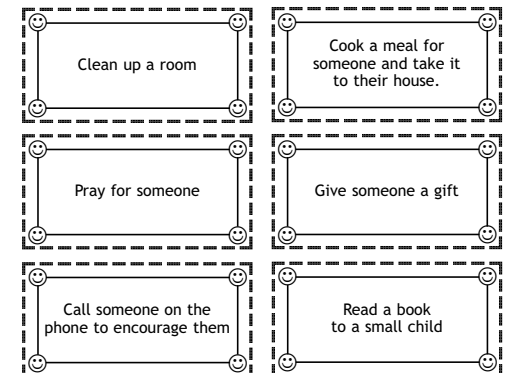

LIFE APPLICATION

Family Service Station

The children will act out "charades" of ways they can serve God with their families.

Materials

For the teacher:

- large writing surface
- baseball cap
- watch with a second hand or timer
- a box or small container
- scissors

Reproducible Pages:

- Page C, 1 copy for the teacher

Preparation

1. Cut out the coupons from your copy of Reproducible Page C.
2. Fold the coupons and place them in the box.
3. On the large writing surface, print the following words in large letters: Family Service Station.

Reviewing the Bible Story

As the children arrive, seat them in a circle and direct them to the words you have written. Read them aloud to the group. Tell them that today they will act out some ways that they can serve their families. Begin by reviewing this week's Bible Story. *We learned that when Abraham was old, he wanted to get a good wife for Isaac, as God commanded. Abraham made his servant promise that he would return to Abraham's homeland and find a wife for Isaac. The servant obeyed. He went to Abraham's homeland. When he got there, he stopped at a well outside a town and asked God to help him know which woman was to be the wife of Isaac. He prayed that it would be the one who would give him a drink of water and water his camels also. Before the servant ended his prayer, Rebekah came to the well. Then the servant asked her for a drink. She was eager to serve him, as well as water his camels. Rebekah invited the servant to her home. Rebekah's father allowed her to go back with Abraham's servant to marry Isaac. She traveled back and Isaac married her.*

Life Application

In this story, we saw how two families were devoted to God. Now we are going to act out some ways that our families can be devoted to God. This activity is called "Family Service Station." Some of you will come up and act out for the group one way your family can serve God and others. The rest of the group will guess what you are doing. You will wear this baseball hat to show that you are the Family Service Station attendant, and you will choose one piece of paper. Then, you will act out the words on the paper for the group. Tell the children that they have three minutes to make the group guess. After three minutes, their time is up.

Choose a child to stand in front of the group, wear the baseball cap and take a piece of paper. Look at the paper and make sure the child understands the words on his coupon. Remind the child that he may not speak when he acts it out. He may use sounds or make noises—but no words should be spoken. Tell the child when to begin and time him for three minutes. If the group has not successfully guessed after time is up, give the answer. Encourage all the children's attempts.

If time permits, encourage the children to think up additional ways that they or their families can serve others. Write their ideas on the large writing surface.

Conclusion

Close with a prayer thanking God for families and asking for his help so that the children's families can serve others.

Teacher Tips

- You may want to make additional charades for the children to act out if your group is much bigger than six.

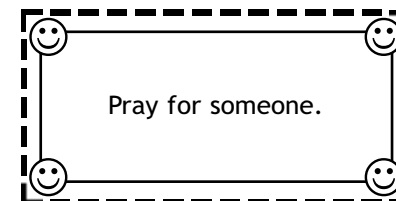

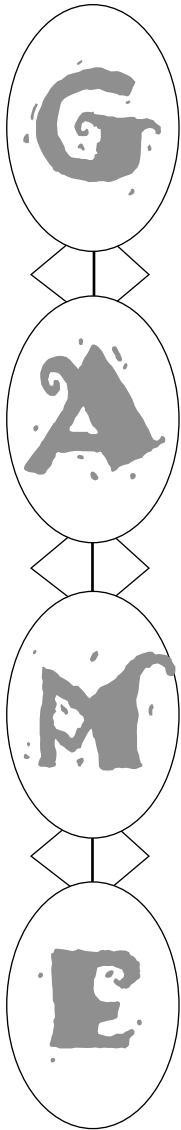

Service with a Smile

The children will participate in several types of relays. During the game, they will hand off a relay baton and name one way that Isaac and Rebekah's families served God.

Materials

For the teacher:

- 2 cardboard rolls
- aluminum foil
- large writing surface
- two medium boxes
- scissors

Reproducible Pages:

- Page D, 1 copy for the teacher

Preparation

1. Label one box for Team 1 and the other for Team 2.
2. Cut out both sets of questions from your copy of Reproducible Page D. Fold one set and place it in the box for Team 1. Do the same with the other set for Team 2.
3. Wrap the cardboard rolls in aluminum foil to make them look like relay batons. Place one in each box.
4. Mark off the "start" and "finish" lines for the relay area.

Instructions

1. As children arrive, tell them that today they will play a relay game in which they have to think of ways that different people in the Bible Story showed devotion to God. Tell them that in order to get credit for an answer, they must give it with a smile. If they are not smiling, they will have to say it again until they do. This will help remind them that God wants us to be happy to serve him.
2. Briefly review how Abraham's family showed devotion to God. *When Abraham was old, he wanted to get a good wife for Isaac as God commanded. Abraham made his servant promise that he would return to Abraham's homeland and find a wife for Isaac. The servant obeyed. He went to Abraham's homeland. When he got there, he stopped at a well outside a town and asked God to help him know which woman was to be the wife*

of Isaac. He prayed that it would be the one who would give him a drink of water and water his camels also. Before the servant ended his prayer, Rebekah came to the well. Then the servant asked her for a drink. She was eager to serve him, as well as water his camels. Rebekah invited the servant to her home. Rebekah's father allowed her to go back with Abraham's servant to marry Isaac. She traveled back and Isaac married her.

3. Divide the group into two teams. Make sure to put the children who did not hear this week's Bible Story with those who did. Line them up and have them stand about three feet from their team's box. If there are more than five children on a team, pair them up so that everyone gets to play.
4. Give the signal. The first children in line must walk quickly to their team's box, take the baton and one piece of paper and return to their team to read the questions they picked. The children who chose the questions must give one way that the person on the paper showed devotion to God—and the children must answer with a smile or they will have to say it again! Answers should closely match those provided on the back of this lesson card. Once a team answers, the next child in line takes the baton and goes up to the box, takes another question and returns with the baton to read the question. The relay continues until both teams have answered all the questions correctly—and with smiles. The first team to finish is the winner.

Conclusion

Close with a prayer thanking God for the ability to have fun, be happy and work together with friends.

Teacher Tips

- Be flexible with the answers. Help the children be successful by guiding them to arrive at the correct answers.

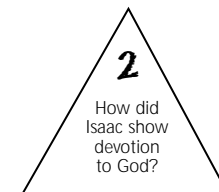
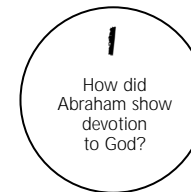



How did Abraham show devotion to God?

Correct answers, with smiles, may include:
He obeyed God's commands;
he sent his servant to find a good wife for his son.

How did Abraham's servant show devotion to God?

Correct answers, with smiles, may include:
He obeyed his master Abraham;
he prayed to God to help him find the right wife for Isaac;
he traveled a long way;
he returned with a wife for Isaac.

How did Isaac show devotion to God?

Correct answers, with smiles, may include:
He obeyed God's commands to marry a good wife;
he waited for the servant to return.

How did Rebekah show devotion to God?

Correct answers, with smiles, may include:
She showed kindness to the servant, who was a stranger;
she invited the servant to her home;
she followed the servant back to Abraham's home;
she married Isaac.

How did Rebekah's father show devotion to God?

Correct answers, with smiles, may include:
He let his daughter leave to marry Isaac;
he believed that it was God's plan for her to marry Isaac.



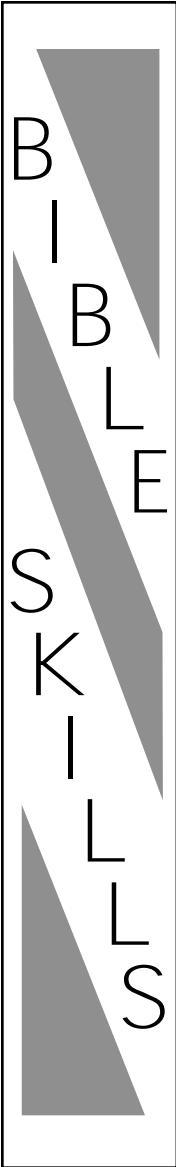

Book Reports (Books of Poetry)

The children will learn a special phrase to help them better understand the contents of the Books of Poetry from the Bible. They will continue to review the books and phrases from Genesis through Esther.

Materials

For each child:

- a pencil

For the teacher:

- large writing surface
- step stool or sturdy milk crate

Reproducible Pages:

- Page E, 1 copy for each child

Preparation

On the large writing surface, neatly print the five Books of Poetry in large letters: Job, Psalms, Proverbs, Ecclesiastes, Song of Songs. Leave space to write beneath each book name.

Instructions

1. As children arrive, show them the words that you have written on the large surface. Remind them that they are the Old Testament Books of Poetry that they learned a few weeks ago. Say each book name and have the children repeat after you.
2. Distribute the copies of Reproducible Page E and pencils to the children. Tell the children that as they learn about each Bible Book of Poetry, they will connect it to the correct phrase on their paper.
3. Under the word "Job" on the large writing surface, write the phrase "Faithful in Hard Times." Tell the children to circle the word Job on their papers. Explain that the book of Job is about a man named Job who had a lot of hard things happen to him, but through them he learned to grow in his faith. Tell the children to circle the phrase "Faithful in Hard Times" on their papers and draw a line to connect it to Job.
4. Under the word "Psalms" on the large writing surface, write the phrase "Song Book." Tell the children to circle the word Psalms on their papers. Explain that the book of Psalms is a collection of songs written mostly by king David about his relationship with God. Tell the children to circle the phrase "Song Book" on their

papers and draw a line to connect it to Psalms.

5. Under the word "Proverbs" on the large writing surface, write the phrase "Wise Words." Tell the children to circle the word Proverbs on their papers. Explain that the book of Proverbs was written by King Solomon, who was the son of King David and the wisest man who ever lived. It is full of wisdom and advice. Tell the children to circle the phrase "Wise Words" on their papers and draw a line to connect it to Proverbs.
6. Under the word "Ecclesiastes" on the large writing surface, write the phrase "Meaning of Life." Tell the children to circle the word Ecclesiastes on their papers. Explain that the book of Ecclesiastes was also written by Solomon and is the story of his search for the meaning of life. Tell the children to circle the phrase "Meaning of Life" and draw a line to connect it to Ecclesiastes.
7. Under the words "Song of Songs" on the large writing surface, write the phrase "Love Song." Tell the children to circle the words Song of Songs on their papers. Explain that this book was also written by Solomon and is his love song to his wife. Tell the children to circle the phrase "Love Song" and draw a line to connect it to Song of Songs.

Step Right Up

Invite the children to take turns stepping up on the stool or milk crate and give a "book report" on one of the Books of Poetry. Do one as an example, saying: *My book report is on the book of Proverbs. It was written by King Solomon and is full of wisdom and advice.* Let as many children go as time permits.

Conclusion

Close with a prayer thanking God for the Bible and all the wonderful and beautiful things we can read in it.

Teacher Tips

- Don't be boring! Show your personal appreciation for the beauty of the Scriptures as you present this activity.



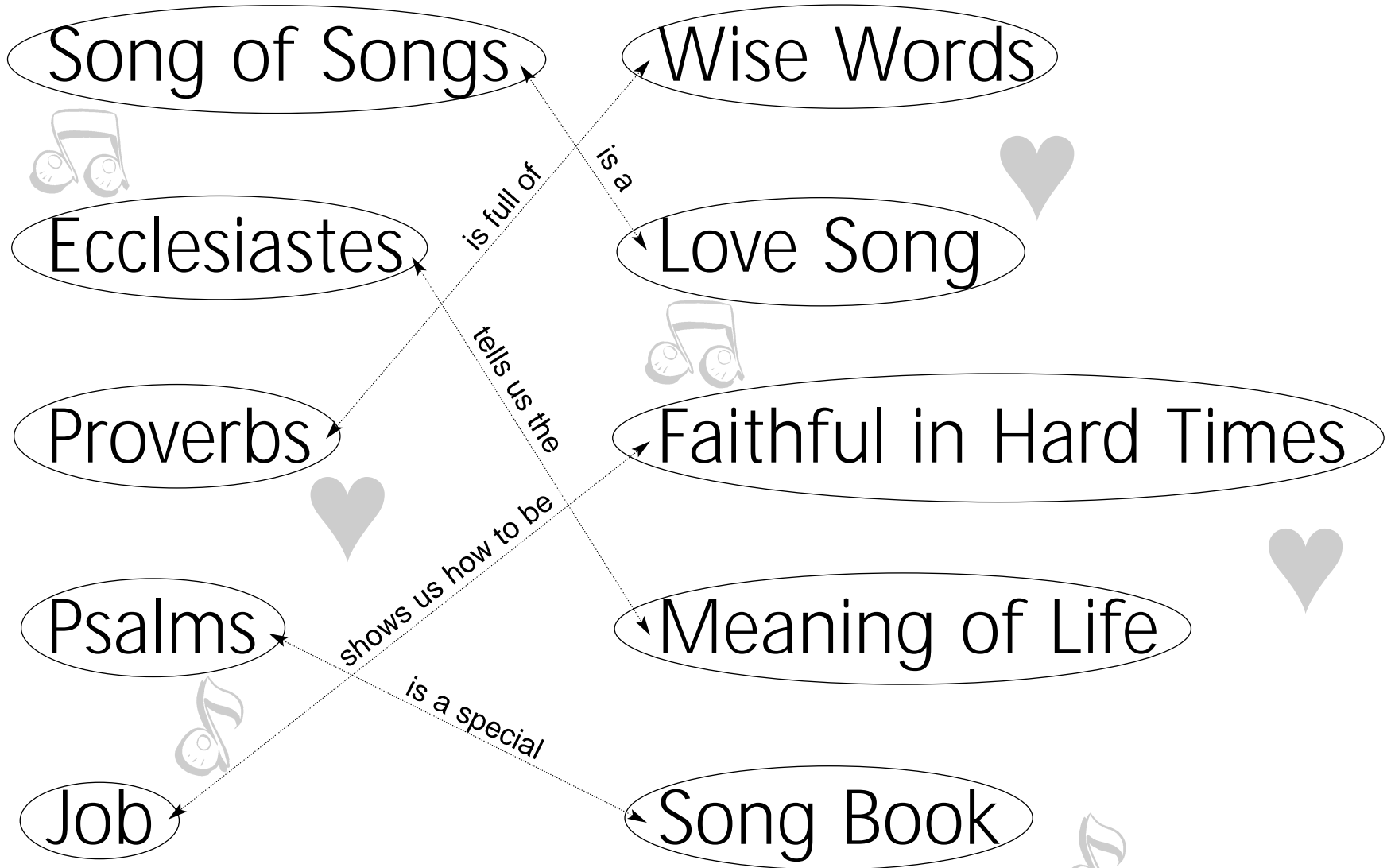

Core/Preclass
1 copy for each child

R
E
P
R
O
D
U
C
I
B
L
E

PAGE
A

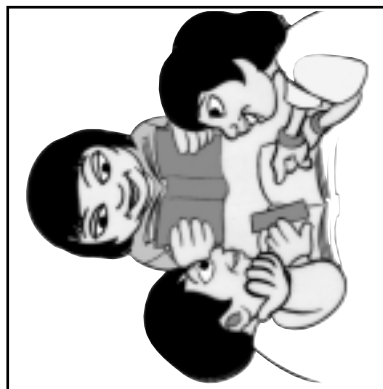
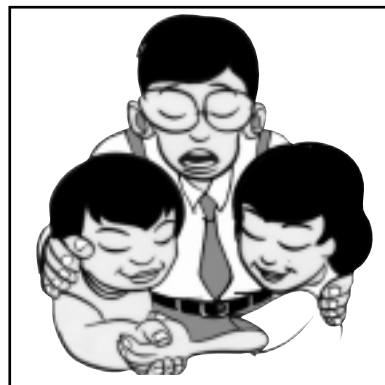

Name: _____



Family
Servers



Core/Craft
1 copy for each child

R
E
P
R
O
D
U
C
I
B
L
E

PAGE
B

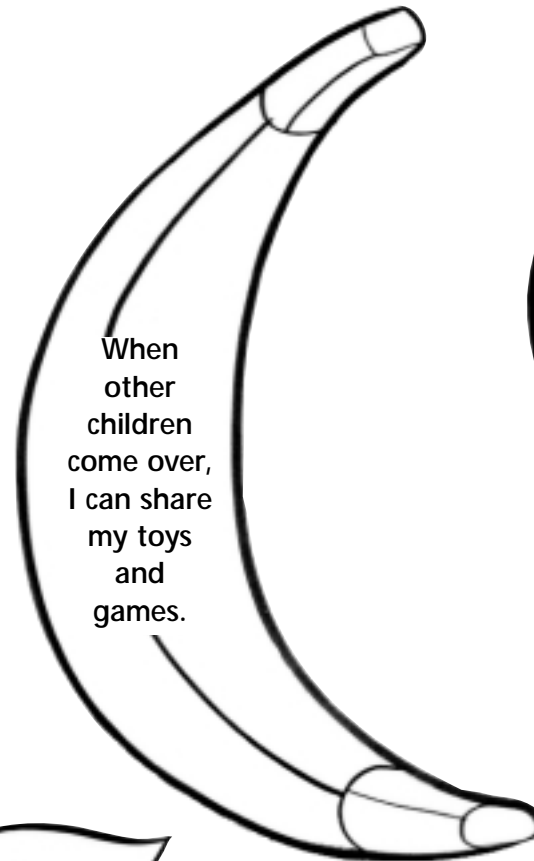

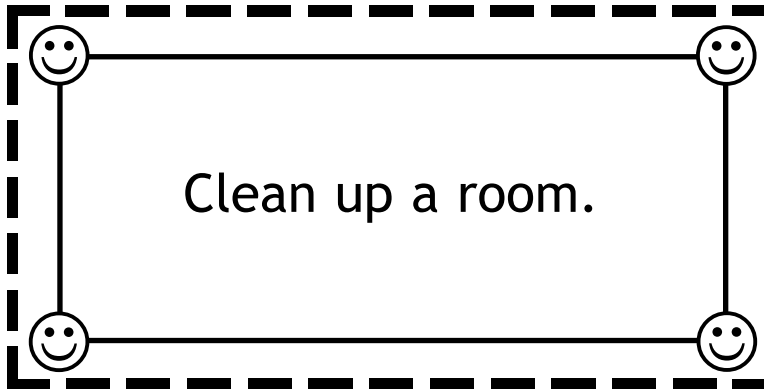

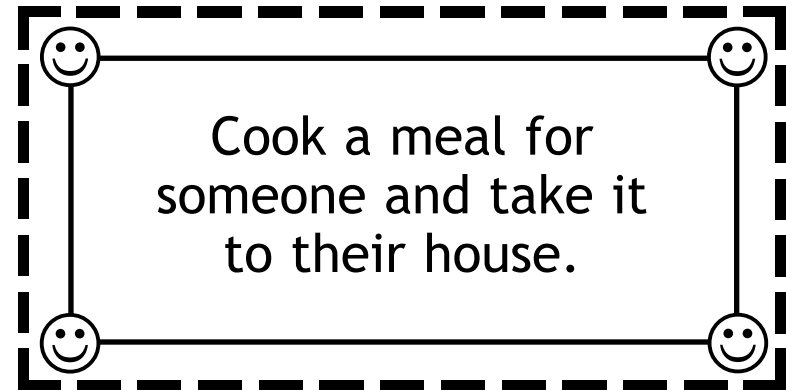

Clean up a room.

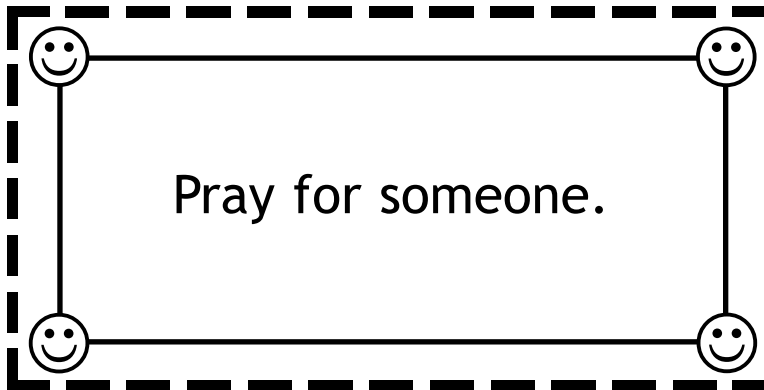

Cook a meal for someone and take it to their house.



Pray for someone.



Give someone a gift.

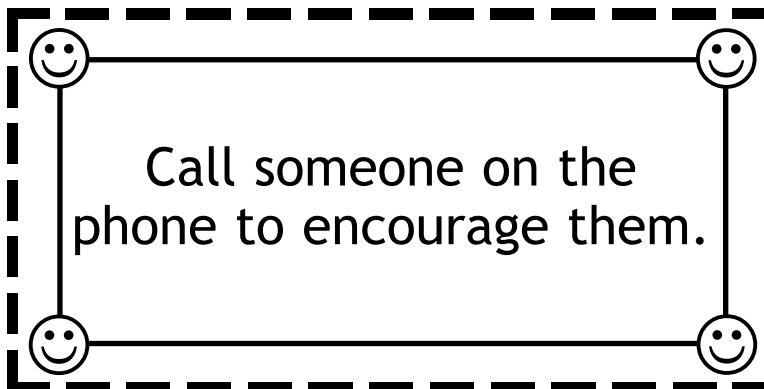

Call someone on the phone to encourage them.

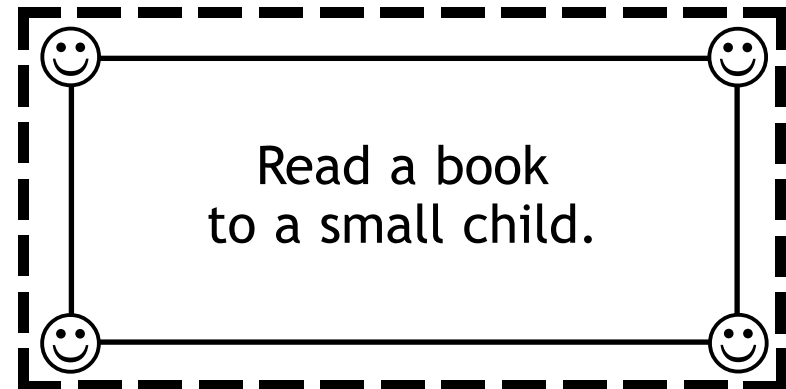

Read a book to a small child.



Supplement/Game
1 copy for the teacher

1
How did Abraham show devotion to God?

1
How did Isaac show devotion to God?

1
How did Abraham's servant show devotion to God?

1
How did Rebekah show devotion to God?

1
How did Rebekah's father show devotion to God?

2
How did Abraham show devotion to God?

2
How did Isaac show devotion to God?

2
How did Abraham's servant show devotion to God?

2
How did Rebekah show devotion to God?

2
How did Rebekah's father show devotion to God?

Supplement/Bible Skills

1 copy for each child

R
E
P
R
O
D
U
C
I
B
L
E

PAGE

E

Song of Songs



Ecclesiastes

Proverbs



Psalms



Job

Wise Words



Love Song



Faithful in Hard Times

Meaning of Life



Song Book

