

Creation of Man

In the Beginning
Lesson 2

Lesson Objectives

- The children will describe how God created man and woman.
- The children will explain how God made Adam special.
- The children will state two ways God provides for them.

Lesson Text

Genesis 1:27, Genesis 2

Scripture Memory Verse

The LORD God said, "It is not good for the man to be alone. I will make a helper suitable for him."

Genesis 2:18

Lesson Plan

Greeting and Registration

Preclass Activity: God Gives Life

Welcome and Singing

Centers:

Bible Story: Adam's ABCs

Craft: Special Delivery

Scripture Memory: Hats Off

NOTE: Allow time for a snack.

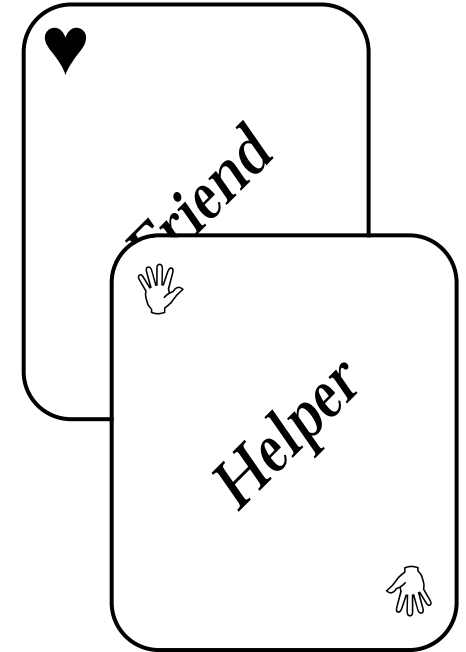

Creation of Man

God Gives Life

In this activity, the children will create figures of people from modeling clay or play dough.

Materials

For each child:

- modeling clay or play dough, approximately 2 handfuls
- 1 piece of cardboard, 9" x 12"
- crayons
- 1 pencil

For the teacher:

- plastic table cover
- extra modeling clay or play dough

Reproducible Pages:

- Page A, 1 copy for each child

Preparation

1. Prepare the clay or dough in advance so that it is ready for the children when they arrive. It should be soft and moldable.
2. Cover the Preclass workspace with a protective plastic cover.
3. Make a model of the man and woman figures to show the children.

Instructions

1. As the children arrive, direct them to the workspace and show them your sample figures. Tell them that today's lesson is about how God created man and woman. Tell them that God created man from the dust of the earth and in a similar way, they are going to make a man and a woman from clay.
2. Distribute copies of Reproducible Page A, the cardboard and crayons. Show the children the figures of the man and woman provided on their pages. Tell them to follow the model given and create their figures by molding their pieces of clay to fit the spaces provided. Encourage them to add features such as hair, faces, and clothing by carving into the clay with their fingers or a dull pencil. Tell them to draw a background picture with crayons when they are finished.

3. Make sure the children sign their names on their pages. Set the pages aside on the cardboard for the children to take home at the end of class.

Teacher Tips

- Modeling clay or play dough can be purchased at most toy or craft stores. It can also be made at home with the following recipe:

Cooked Play Dough

1 cup flour	1 cup water
½ cup salt	1 tsp. food coloring (whatever color you want dough to be)
2 tsp. cream of tartar	
2 tablespoons oil	

Combine the flour, salt and cream of tartar in a large saucepan. Gradually stir in water mixed with oil and food coloring. Cook over medium to high heat, stirring constantly until a ball forms. Remove from heat, let cool, and knead until smooth. It is ready to be played with. Store play dough in a TIGHTLY covered plastic container.

IMPORTANT: Dough is extremely hot! Let it cool before kneading.

Reproducible Page A

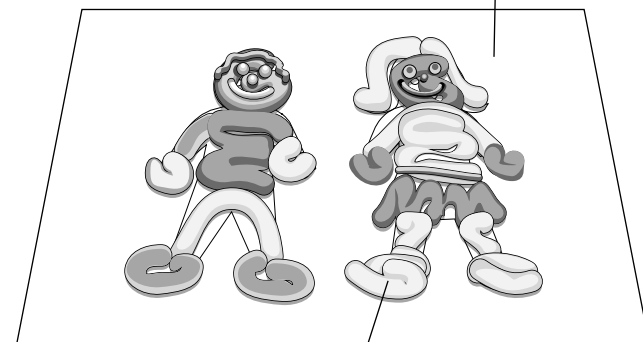

modeling clay

B

Creation of Man

In the Beginning
Lesson 2**S**

Adam's ABCs

The children will learn how God made man and all the special ways he provided for him.

Materials

For the teacher:

- a small mirror

Reproducible Pages:

- Page B, 1 copy for the teacher

Preparation

1. Using your copy of Reproducible Page B, assemble the cube for this activity as follows: Cut out the cube and fold along all dashed lines to create the "sides." Bring all the sides together, with the letters facing outward, to form a cube. Apply tape to hold the sides together.
2. Practice telling the story using the cube and the text provided.

Introducing the Story

Seat the children in a circle around you. Open your Bible to Genesis 2. Begin by saying: *In our last lesson, we learned that God created the world. Today we are going to learn about the creation of man and woman. God did something when he created them that he did not do for any other created things. God made man to be very special, and God took very special care of him. Our story comes from chapters 1 and 2 of Genesis.*

The name of our story today is Adam's ABCs. You will learn some very important ideas about God's creation of man that begin with the letters A,B,C,D,E and F. When I am finished telling you the story, you will tell me what each letter stands for!

Adam's ABCs

Bring out the story cube. Turn to the side with letter "A," saying: *In Genesis 2:7 it says, "...the LORD God formed the man from the dust of the ground and breathed into his nostrils the breath of life and the man became a living being." The Bible says that God made man from the dust of the earth and then he breathed life into him.*

Today, some of you made a man and a woman from clay when you came to class. Did those figures that you made come to life? (No)

Were they alive? (No) If you breathe on them, will they be alive? (No) Only God can give life. God made Adam ALIVE. "A" stands for ALIVE. Have the children say the word "alive."

Turn to the side with letter "B," saying: *In Genesis 1:27 it says, "So God created man in his own image, in the image of God he created him; male and female he created them." The Bible says that God created man in his own image. Take out the mirror. An image is something we see. Look in this mirror, what do you see? You see your image! (Pass the mirror around.) God created man in his image, because God wanted man to be like him. How many of you are like your mother? How many of you are like your father? That is because they helped to create you. When God created man in his image, he wanted people to be like him, to do what he would do, to treat people as he would treat them. God created Adam to BE like him. God created man to think and feel and love, like God. He also gave us a soul that will live forever. "B" stands for BE like God. Have the children say the word "be."*

Turn to the side with letter "C," saying: *In Genesis 2:15 it says, "The LORD God took the man and put him in the Garden of Eden to work it and take care of it." How many of you have a garden at home? Who takes care of your garden? Do you help? The Bible says that God put the man in the garden to take care of it. God wants us to take care of the things he gives to us. He does not want us to be careless, but to be careful. God gave the man a beautiful place to live and he told the man to CARE for it. "C" stands for CARE for the garden. Have the children say the word "care."*

Turn to the side with letter "D," saying: *In Genesis 2:16-17 it says, "And the LORD God commanded the man, 'You are free to eat from any tree in the garden; but you must not eat from the tree of the knowledge of good and evil, for when you eat of it you will surely die.'" The Bible says that God made Adam alive and special! God put him in the garden to take care of it. Then, God gave Adam a rule. He told him that he could eat from any tree in the garden except one. God told Adam that he must not eat from the tree of the knowledge of good and evil. God knew that if the man ate from that tree, he would die. God did not want the man to die. "D" stands for DON'T eat from the tree of the knowledge of good and evil. Have the children say the word "don't."*

I**T****B****O****L****R****E****Y**

Creation of Man

Turn to the side with letter "E," saying: *In Genesis 2:8 it says, "Now the LORD God planted a garden in the east, in Eden; and there he put the man he had formed." The Bible says that God planted a garden and it was called Eden. Then he placed the man he had made in the garden. God gave Adam a beautiful home! No one has ever lived in a place as beautiful as God's garden in Eden. It was a perfect place. "E" stands for EDEN and all the special things there that God gave Adam. Have the children say the word "Eden."*

Turn to the side with letter "F," saying: *In Genesis 2:18 it says, "The LORD God said, 'It is not good for man to be alone. I will make a helper suitable for him.'" The Bible says that even after all the special ways that God took care of Adam, he was still alone. God said that it was not good for Adam to be alone. God does not want anyone to be alone. That is why he gives us friends and people who will help us. God made Adam fall into a deep sleep. While Adam was sleeping, God took one of his ribs and made a woman. When Adam woke up, there was another person there! It was a woman. Adam called her Eve. She became his helper and his friend. "F" stands for FRIENDS and helpers that God gives us. Have the children say the word "friends."*

Now I Know My ABCs

Review each letter of Adam's ABCs with the children. Let them take turns saying what each letter stands for.

Share and Tell

It makes me feel special when someone loves me. God really made Adam feel special. We can make God feel special when we tell others about him. Can you think of someone who needs to feel special? We can tell our Bible Story to that person. Ask the children who they will share Adam's ABCs with when they go home today. Close with a prayer to thank God for the special ways he made and cares for each child.

Teacher Tips

- The children need to see your personal appreciation for the ways that God has made and cared for you. Make sure to come to class spiritually prepared to give to the children.



Creation of Man

Special Delivery

The children will make a bracelet that reminds them of specific ways that God made them unique and special.

Materials

For each child:

- pencils
- thin markers
- crayons
- 1 strip of clear contact paper, 4" x 8"
- 1 brass fastener

For the teacher:

- large writing surface
- scissors
- invisible tape

Reproducible Pages:

- Page C, 1 copy for each child

Preparation

1. Cut out the wristband strips from the copies of Reproducible Page C for each child. Cut a few extra to allow for mistakes.
2. Make a sample wristband for yourself to show the children.
3. Cut the strips of clear contact paper for each child.
4. Make four columns on the large writing surface titled: Name, Birthday, Eye Color and Hair Color. Write your name, birthday, eye and hair color in the appropriate columns. During class you will write the words that describe each child.

NOTE: Collect birthday information during registration.

Instructions

1. Introduce today's craft by saying: *In our Bible Story today, we learned about how God made Adam and Eve special and all the ways he took care of them. God made each of you special and he takes care of you too. When you were born, you were a very special gift from God. You were a special delivery! In the hospital, when a baby is born, the nurse puts a special bracelet on the baby. This bracelet has the baby's name and birthday. It shows that this baby is special and that there is no other like it. Today, you are going to make a bracelet that shows that you are*

special and unique—there is no one else exactly like you because God made YOU special!

2. Show the children your bracelet. Show them where you have written your name, birthday, eye and hair color. Tell the children that each of these things makes them unique and special.
 3. Write the name of each child in the Name column. Next to each name, write the child's birthday, eye and hair color in the appropriate columns.
 4. Distribute the children's wristband strips that you prepared, pencils and thin markers. Tell the children to write in pencil on their wristband their name, birthday, eye and hair color. Circulate among the children to help them with spelling. The children may write over the pencil in marker if they want.
 5. Distribute the clear contact paper. Show the children how to remove the backing, leaving the sticky side up. Help the children to place their wristband strips on the bottom of the contact paper, as shown in Figure A. Help them fold the top half of the contact paper over to cover the strip, as shown in Figure B. Trim off excess contact paper.
 6. Go around to each child and help them adjust their wristband to the correct size by lining up the holes at the end of the band. They should not be tight. Place a brass fastener through both ends of the wristband, as shown in Figure C and cover with a piece of tape. Trim off excess paper at the end.
- IMPORTANT: Make sure that the fastener opens away from the children's wrists, to avoid irritating or scratching their skin.

Conclusion

Have the children sit in a circle and say one thing about the child to their right that is unique and special. Start by doing the first one, saying, for example: *Rachel is unique and special because she was born on November 6. Or Jimmy is unique and special because he has blue eyes.* Close with a prayer thanking God for the special way he made each child.

Teacher Tips

- If clear contact paper is not available, cover the wristbands with clear tape as a substitute.

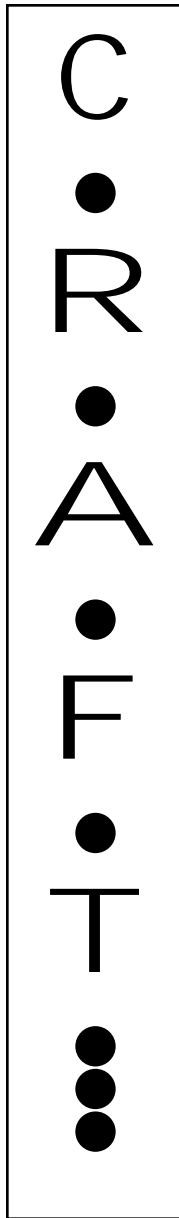

Creation of Man

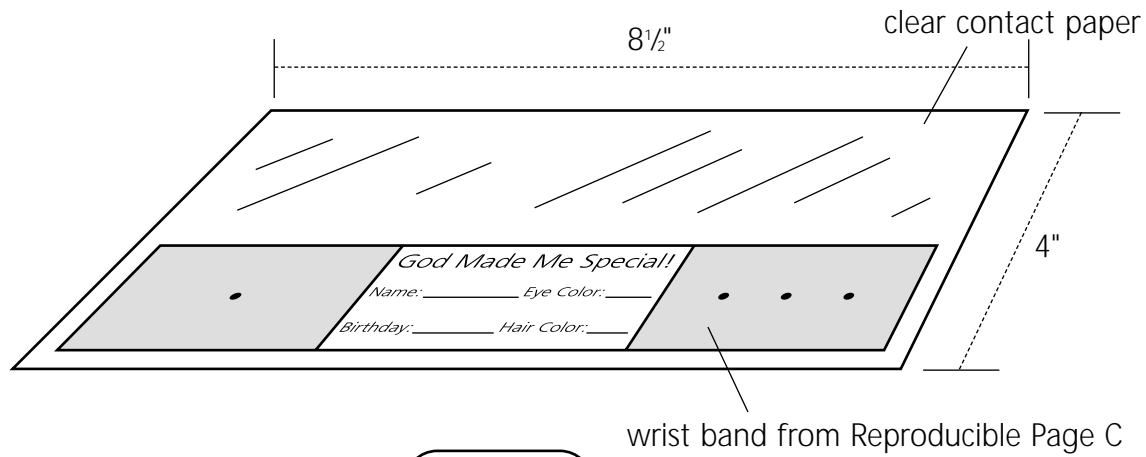

Figure A

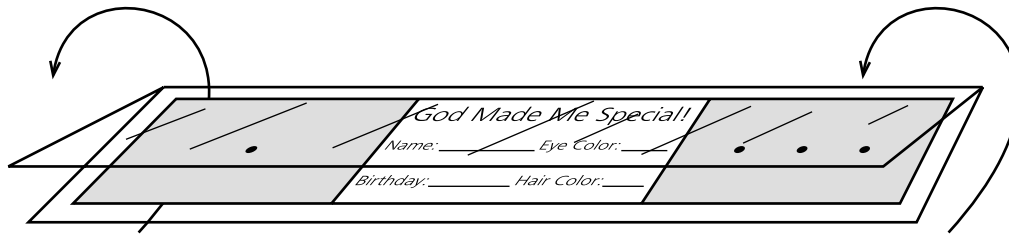

Figure B

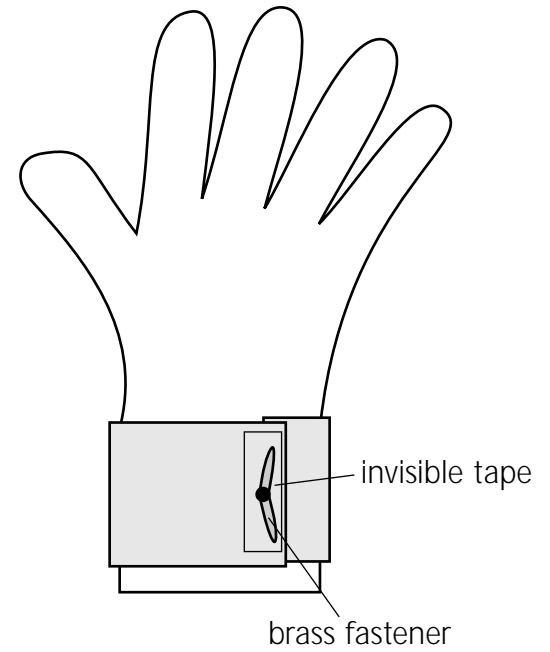

Figure C

Creation of Man

Hats Off

In this activity, the children will use paper hats to help them learn the Scripture Memory Verse by heart.

Scripture Memory Verse

The LORD God said, "It is not good for the man to be alone. I will make a helper suitable for him."

Genesis 2:18

Materials

For each child:

- 1 sheet of newsprint, 12" x 18"

For the teacher:

- 1 black marker
- large writing surface

Preparation

1. For each child make a paper hat following these steps:
 - A. Fold the paper widthwise, as shown in Figure A.
 - B. Bring the upper left and upper right corners to the middle, as shown in Figure B.
 - C. Fold the bottom front flap up over the corners, as shown in Figure C.
 - D. Turn the paper over and fold the back flap up, as shown in Figure D. This is your hat.
2. On the back flaps of the hats, write the Scripture Memory Verse, one phrase on each hat, as shown in Figure E. Adjust the phrases to match the number of children in your group. Make sure to include the proper punctuation and capitalization.
3. Write the Scripture Memory Verse on the large writing surface.
4. Know the verse by heart prior to class.

Instructions

1. Introduce today's activity, saying: *In our Bible Story this week, we learned that God made man in his image. That means that God made man to be like him—to feel, to think and to have a soul that lives forever. After God made Adam, he saw that the man was alone. God said that it was not good for the man to be alone. God knows that we need people in our lives. He gives us*

families who take care of us and friends who help us. Today, we are going to help each other learn the Scripture Memory Verse.

2. Say the Scripture Memory Verse to the children three times while they listen.
3. Referring to the large writing surface:
 - A. Say the verse together with the children three times.
 - B. Go around in a circle and say the verse together with each child one at a time.
 - C. Go around in a circle and let each child say the verse alone or with a partner.
4. Pass out the hats to the children and tell them to put them on their heads. Line them up, side by side in the correct order of the verse.
5. Remove the hats and mix them up. Hand them out again. Tell the children to take their hats off and look at the words on their hats. Tell them to put themselves in the correct order of the verse.
6. When they have finished, switch places with one child and wear his hat. Tell him to read the verse aloud to the group. If it is correct, remove all the hats and repeat Step Five. If it is incorrect, switch places with another child and let him check the verse and move the children until it is correct.
7. Repeat Step Five with the children, and keep time to see how quickly they can put the verse together. Remind them to be gentle as they put themselves in order. Let the children do this several times to achieve their fastest time.
8. If time permits, remove one hat at a time and let children take turns trying to guess what is missing from the verse.

Conclusion

Ask the children to name one person that they are glad that God has put in their lives. This can be a friend, family member or special adult (i.e., teacher, etc). End with a prayer thanking God that he gave us people so we would not be alone.

Teacher Tips

- Be sensitive to children who may say they are alone. Help them to think of someone to be thankful for.

SCR
IPT
URE
MEM
ORY



Creation of Man

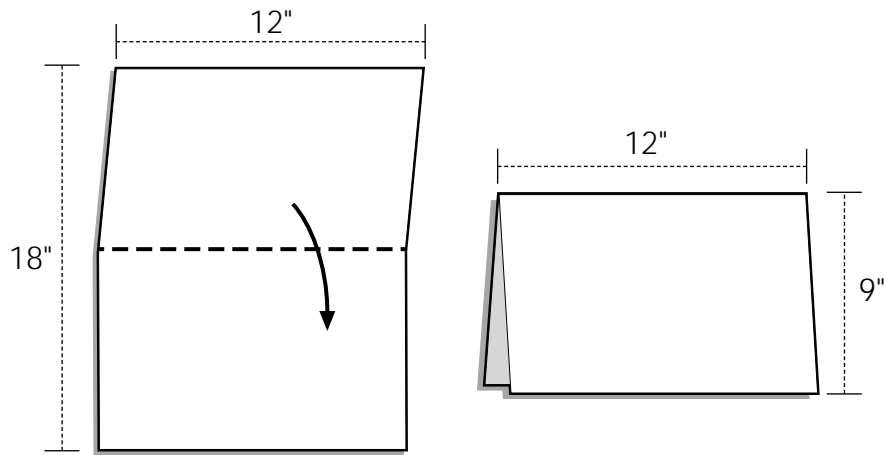

Figure A

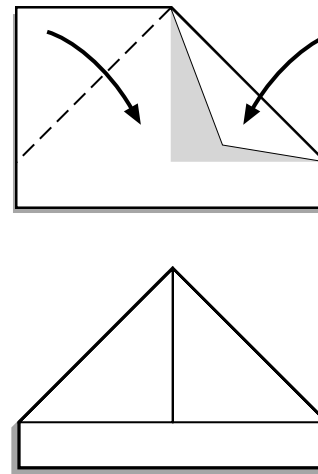

Figure B

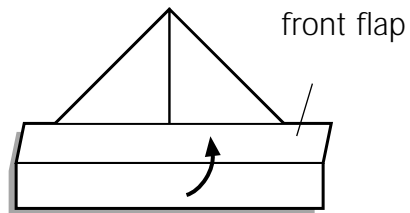

Figure C

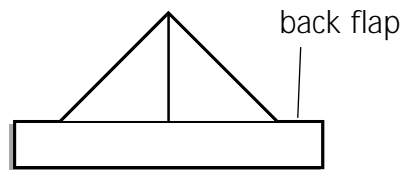

Figure D

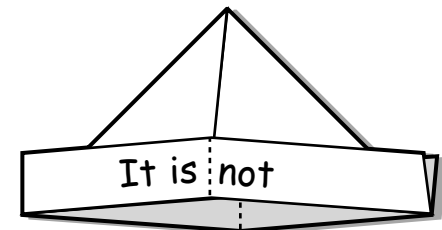
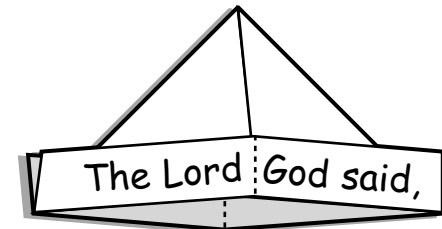

Figure E

Lesson Objectives

- The children will describe how God created man and woman.
- The children will explain how God made Adam special.
- The children will state two ways God provides for them.

Lesson Text

Genesis 1:27, Genesis 2

Scripture Memory Verse

The LORD God said, "It is not good for the man to be alone. I will make a helper suitable for him."

Genesis 2:18

Lesson Plan

Greeting and Registration

Preclass Activity: God is Good to Me

Welcome and Singing

Centers:

Life Application: Friends and Helpers

Game: Guess What?

Bible Skills: Hooray for History!

NOTE: Allow time for a snack.



pre
class

ACTIVITY

God is Good to Me

The children will review this week's Bible Story as they make a collage of ways that God provides for them.

Materials

For each child:

- 1 glue stick
- magazine pictures of nature, food, people, animals

For the teacher:

- scissors
- magazines

Reproducible Pages:

- Page D, 1 copy for each child

Preparation

1. Cut out pictures of nature, food, people and animals for the children to use. They should be small enough to fit in the spaces provided on Reproducible Page D.

2. Make a sample collage to show the children.

Instructions

1. As the children arrive, distribute copies of Reproducible Page D. Show them your sample, saying: *This is a collage—or a collection of pictures. I chose each picture because it shows something good that God has given to me. Each picture shows something that begins with the letters of the alphabet A through F. For example, I chose a picture of animals for the letter A because I love animals. Maybe you will choose a picture of apples or apple trees! Do you remember Adam's ABCs from the Bible Story this week? This collage will help you think about the ABCs of how God takes care of you.*

2. Circulate among the children to offer help. Encourage them to draw pictures or write words of things for which they cannot find a picture.
3. Make sure that the children write their names on their collages.
4. Display the collages in a place where everyone can see them. Make sure that the children take them home after class.

Teacher Tips

- Have an extra supply of magazines and scissors in case you need them.

LIFE
A
P
P
L
I
C
A
T
I
O
N**Friends and Helpers**

The children will describe ways that God provides for them through relationships.

Materials

For each child:

- 6 index cards, 3" x 5"
- 1 envelope, standard letter size

For the teacher:

- glue or tape

Reproducible Pages:

- Page E, 1 copy for each child

Preparation

1. Cut out one set of Friends and Helpers cards from copies of Reproducible Page E for each child.
2. Glue or tape each set of Friends and Helpers cards to the index cards.
3. Place each set in an envelope for each child.

Reviewing the Bible Story

Introduce today's activity by saying: *This week our Bible Story was in Genesis 1 and 2. We learned that God created Adam and gave him everything he needed. Then, God created Eve because he knew that it was not good for Adam to be alone. God knew that Adam needed a friend, someone to help him. God created Adam and Eve and all people to be like him—to feel and think and have a soul that would live forever. He wants people to love and help others. God gives us special people in our lives to help us and to be our friends.*

Friends and Helpers

Show the children the cards that you prepared. Distribute them to the children. Tell them to take the cards out of the envelopes and hold them as if they were playing cards, with the words facing them. Tell the children to listen closely as you ask them some questions. They will choose a card that answers the question and place it face down in front of them.

- *God gives us mothers. A mother is a helper and a friend. Put down the card that you think best describes a mother. After all*

the children have put down a card, turn the cards over. Count the number of Friend and Helper cards, saying, for example: *Three of you said that a mother is a friend and four of you said she is a helper. Let's thank God for mothers.* Choose one child to pray and thank God for mothers.

- *God gives us fathers. A father is a helper and a friend. Put down the card that you think best describes a father. Count the cards as with the previous questions, asking one child to pray and thank God for fathers.*
- *God gives us doctors. A doctor can be a helper and a friend. Put down the card that you think best describes a doctor. Count the cards and ask one child to pray and thank God for doctors.*
- *God gives us teachers. A teacher can be a helper and a friend. Put down the card that you think best describes a teacher. Count the cards and ask one child to pray and thank God for teachers.*
- *God gives us neighbors. A neighbor can be a helper and a friend. Put down the card that you think best describes a neighbor. Count the cards and ask one child to pray and thank God for neighbors.*
- *God gives us brothers and sisters. A brother or sister can be a helper and a friend. Put down the card that you think best describes a brother or sister. Count the cards and ask one child to pray and thank God for brothers and sisters.*

Making Connections

Remind the children that God has provided them with very special people to love and care for them. Ask each child to name one special person that they will say "I love you" to when they go home today.

Teacher Tips

- You may want to laminate the cards or cover them with clear contact paper for greater durability.



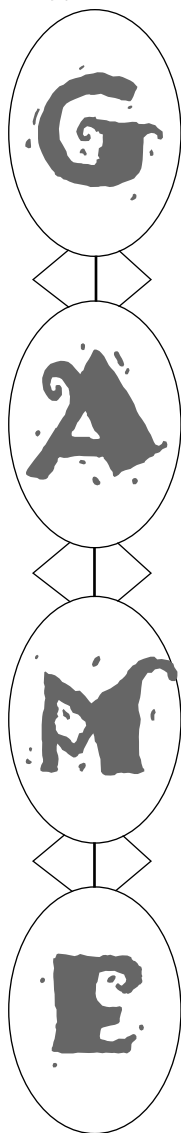

Guess What?

The children will think about ways they are unique in this fun guessing game.

Materials

For the teacher:

- 16 pieces of paper, 2" x 2"
- 1 hat
- large writing surface
- thin marker

Preparation

1. On the sixteen pieces of paper, print the following words: Eat, Bark, Talk, Breathe Under Water, Fall In Love, Choose, Walk on Two Feet, Fly, Pray, Be a Doctor, Help Somebody, Sleep, Read the Bible, Build a House, Play Piano, Laugh.
2. Fold the pieces of paper and place them in a hat.
3. On the large writing surface, draw two large overlapping circles, as in a Venn diagram. At the top of one circle, write the words Animals, Birds and Fish. On the top of the other circle write the word People. See Figure A.

Instructions

1. Introduce today's game by saying: *In our Bible Story this week, we learned that God made man in his image. We learned that to be made in God's image means to be made like God. God created man to have feelings, to think and to choose. God created man to rule over the earth and take care of it. God gave man a soul that would live forever. God created man to do things that were different from the animals, birds and fish. God made man to be special—to be like him. In our game, we are going to think about some ways that people are like the other animals that God made and ways that they are different.*
2. Show the children the hat you have prepared. Tell them that inside the hat there are some words written on small pieces of paper. They will take turns choosing one piece of paper and acting out the word for the group. Some words will be easy and some will be hard. They may point and make sounds, but they cannot talk. Tell the children that once they have guessed what is

written, you will ask them: *Is this something an animal, bird or fish can do? Is this something a person can do? Is this something that they all can do?* You will write their answer on the chart.

3. Begin by acting out the first word for the children. Act out "Crawl." After the children have guessed what you are doing, ask them: *Is this something an animal, bird or fish can do? (Yes) Is this something a person can do? (Yes) So, is this something that they all can do? (Yes)* Write "Crawl" in the space where Animals, Birds, Fish and People overlap, as shown in Figure B.
4. Choose a child to pick a word from the hat. Be sure that he understands the word written on his paper. Let him act it out for the group. When the children have guessed, ask the questions from Step Three and write the correct answer on the diagram. If they cannot guess the correct word, tell them what it is and then ask the questions.
5. Continue until all the actions have been acted out and written in the diagram. The final diagram should look something like the diagram in Figure C.

Conclusion

Help the children to see the main difference between people and all other creatures is that people have souls that will live forever. End with a prayer thanking God for each child and all the special things that they can do.

Teacher Tips

- Help the children who have difficulty acting out their words.
- Be prepared for some children who want to differ. For example: If a child says that some birds can talk, tell them that certain birds like parrots can imitate the sounds of words, but they cannot communicate with people or have a conversation. Acknowledge that animals can communicate with each other, but no other creature has been given the ability by God to speak in different languages. You may also want to acknowledge that some animals have shown remarkable abilities to do different things, but no other species of animal has developed these abilities the way that God created man to develop them.



Creation of Man

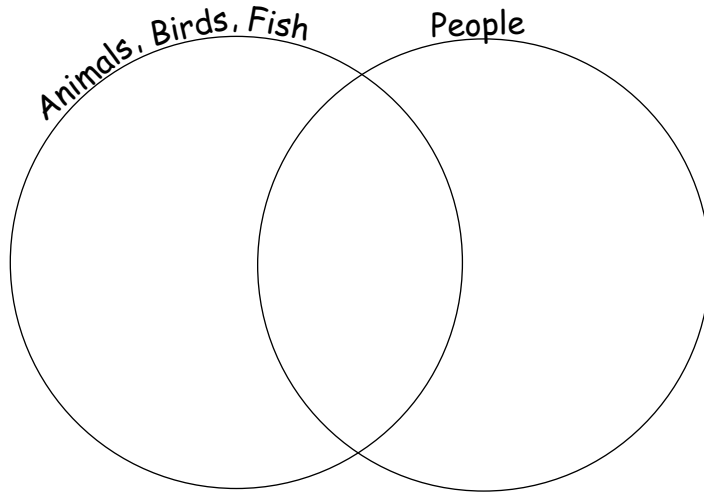
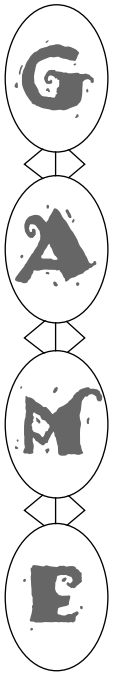

Figure A

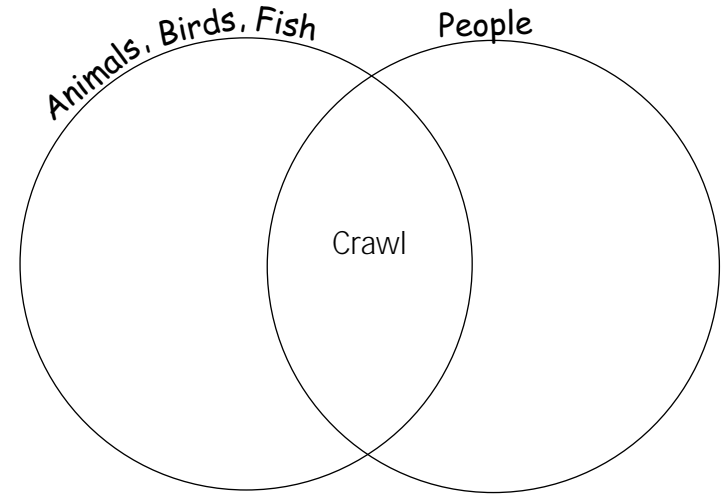

Figure B

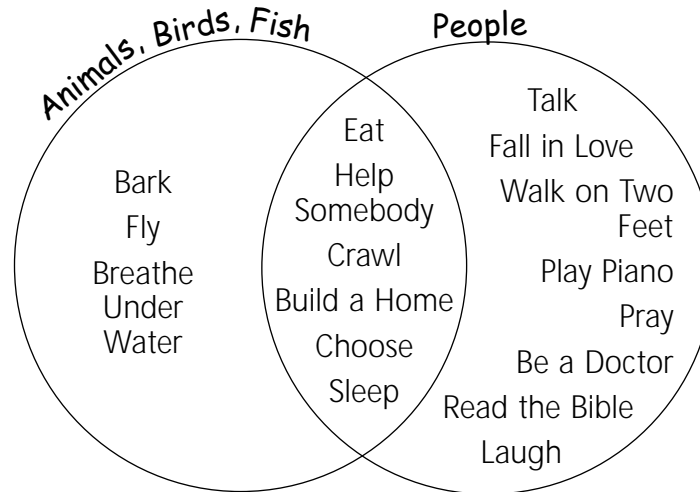
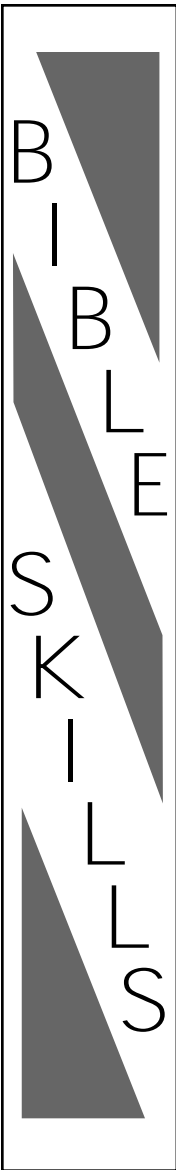

Figure C





Hooray for History! (Books of History)

The children continue their adventure on the Bible Train as they learn the names of the Old Testament Books of History.

Materials

For the teacher:

- invisible tape
- 1 black marker
- 12 train cars from copies of Reproducible Page E from Unit 1 Lesson 1 Bible Skills

Reproducible Pages:

- Page F, 1 copy for each child

Preparation

1. Write the next twelve books of the Bible—Joshua, Judges, Ruth, 1 and 2 Samuel, 1 and 2 Kings, 1 and 2 Chronicles, Ezra, Nehemiah, Esther—on twelve train cars from the copies of Reproducible Page E from Unit 1 Lesson 1 Bible Skills. (Put “1 and 2” books on same train car, if you prefer.) Attach them with invisible tape to the Bible Train that you prepared in Unit 1 Lesson 1 to form a “train.” See the diagram on the back of this lesson card.
2. Learn the twelve Books of History by heart.
3. Practice this activity at home.
4. Display the Bible Train with the books from today’s lesson and Unit 1 Lesson 1 Bible Skills in a place where all the children can see it.

All Aboard the Bible Train!

NOTE: These children are young readers. Always point to each car of the Bible Train as you say it.

As the children arrive, seat them where they can see the Bible Train. Tell them that today they are going to learn the next twelve books of the Old Testament, called the Books of History.

History can be very exciting! Who can think of some important events in our history? Let the children respond. History is so important because it teaches us about our past. The Bible is full of history. It teaches about the men and women who changed the world because of their love for God and their faith in his word. Because of

the Bible, we know about Noah, Moses, Joshua, Ruth, David, Mary, Jesus and many others! We need our Bible history so that we can know how to follow God the way they did!

Point out the twelve new books that you added to the Bible Train. Say them to the children and have them repeat after you. Do this several times. Tell the children that you are so excited about the Books of History from the Bible. Today, they will show that they are excited too! Tell the children that they are going to make up a cheer for the Old Testament Books of History. As you say a book, they will stand up and say the book, doing the actions described below. Introduce each book, saying: *Give me _____* and doing the action. For example: with your hands on your hips, say: *Give me Joshua*. The children call out Joshua and imitate your action.

Joshua	hands on hips
Judges	arms out in front
Ruth	arms straight up over head
1 and 2 Samuel	hands on hips
1 and 2 Kings	arms out in front
1 and 2 Chronicles	arms straight up over head
Ezra	hands on hips
Nehemiah	arms out in front
Esther	arms straight up over head

Repeat this activity, using the actions but saying only the book names. Do this several times with increasing speed. Invite the children to try and do it on their own or with a partner.

Conclusion

Distribute copies of Reproducible Page F to the children, encouraging them to trace the words at home. *The Bible is full of great things that we can tell others. Today we learned that it is full of history. The word “history” looks like the two words “his” and “story” and that is what the Bible is to God: his story! Let’s all say a prayer together thanking God for the Bible.* Close with a prayer.

Teacher Tips

- You may want to make up other actions for the children to do during this activity or let them come up with some of their own.



Creation of Man

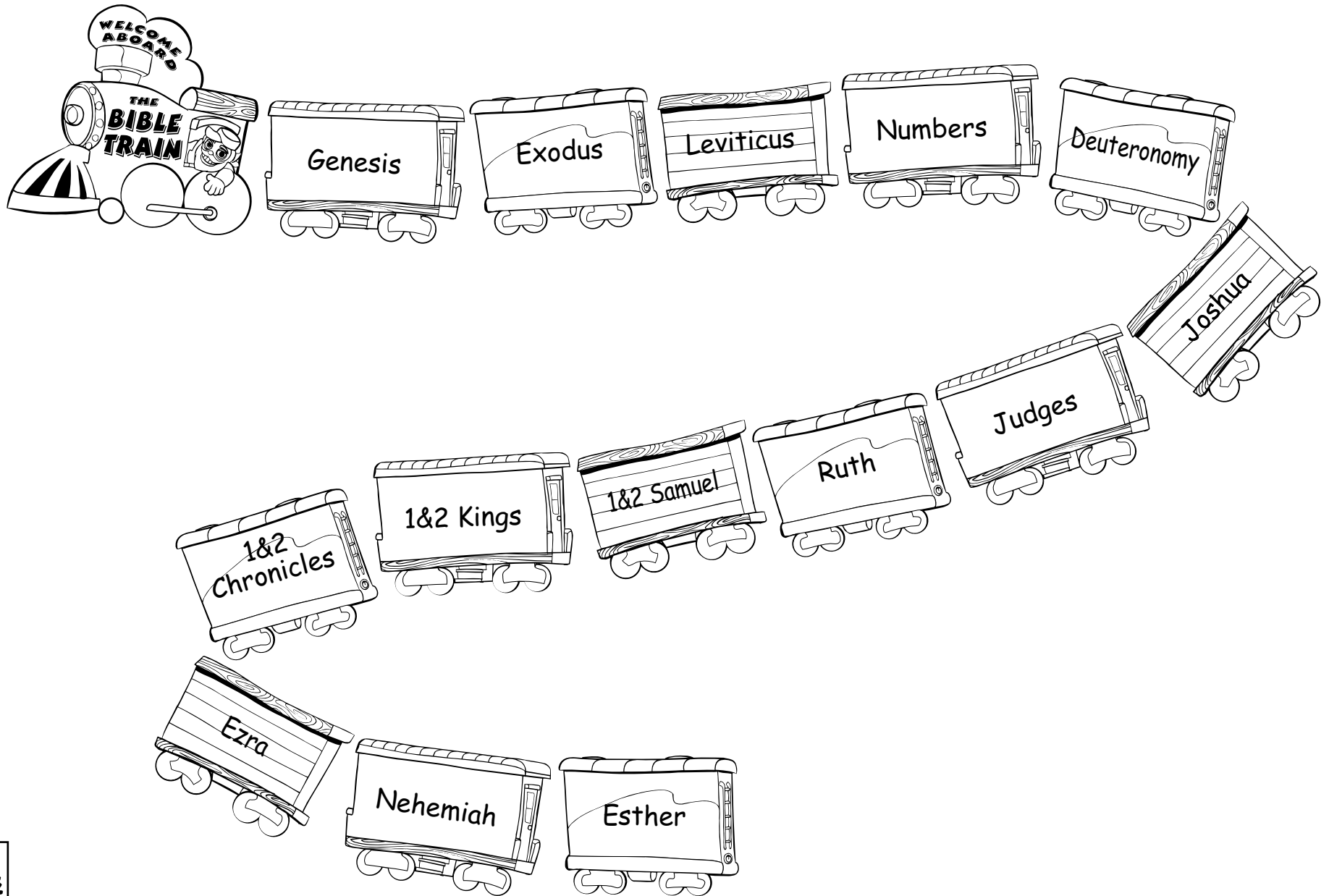

R
E
P
R
O
D
U
C
I
B
L
E
P
A
G
E
A

Core/Preclass
1 copy for each child

In the Beginning
Lesson 2

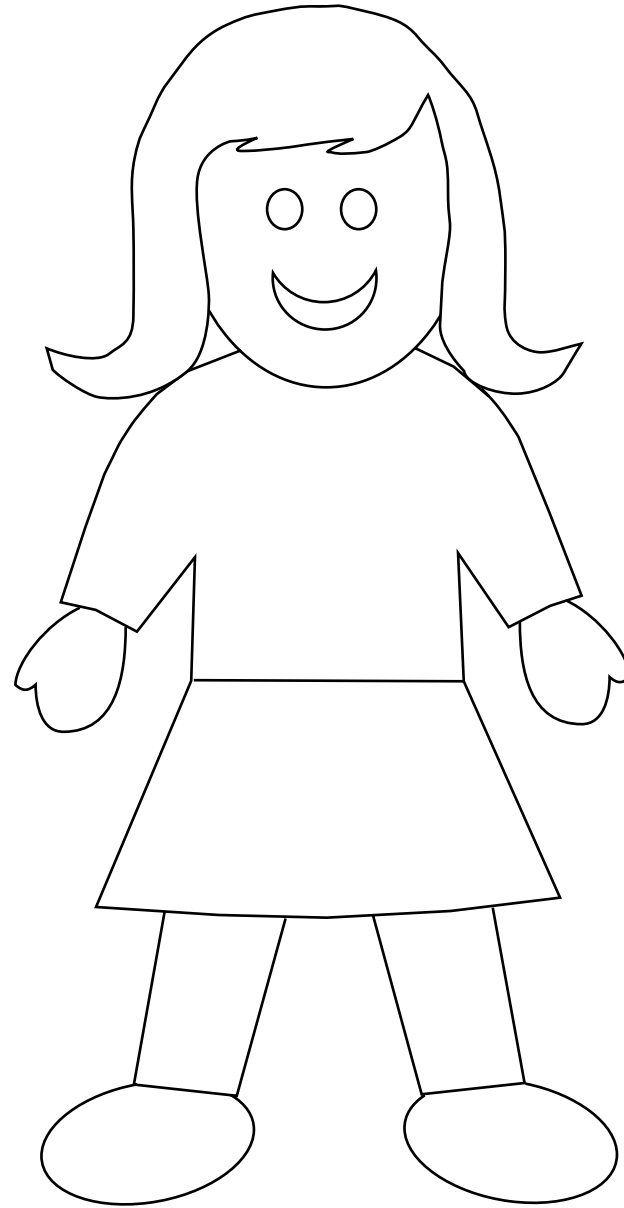
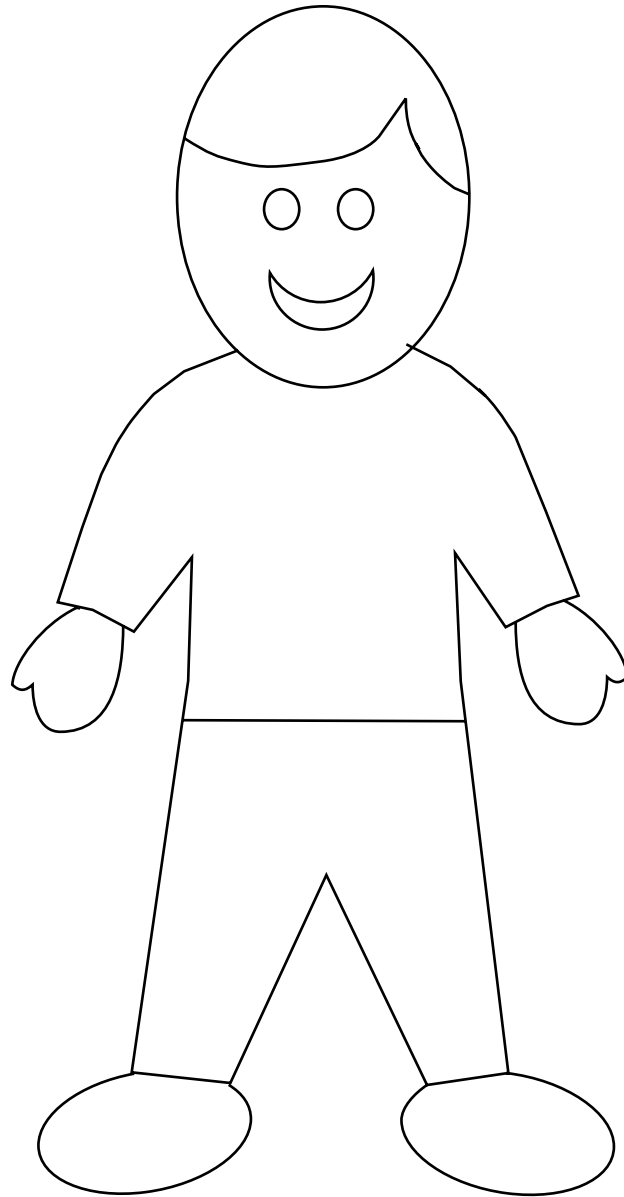

Core/Bible Story
1 copy for the teacher

Friends and Helpers
Genesis 2:18

Genesis 2:7

Alive

Genesis 1:27

Be Like God

Genesis 2:15

Care for Garden

Genesis 2:16-17

Don't Eat from Tree

Genesis 2:8

Eden

R
E
P
R
O
D
U
C
I
B
L
E
PAGE
B



R
E
P
R
O
D
U
C
I
B
L
E
P
A
G
E
C

Core/Craft
1 copy for each child

In the Beginning
Lesson 2

●	God Made Me Special! Name: _____ Eye Color: _____ Birthday: _____ Hair Color: _____	● ● ●
---	--------------------------------------------------------------------------------------------------	-------



This page intentionally left blank



Supplement/Preclass

1 copy for each child

R
E
P
R
O
D
U
C
I
B
L
E
P
A
G
E
D

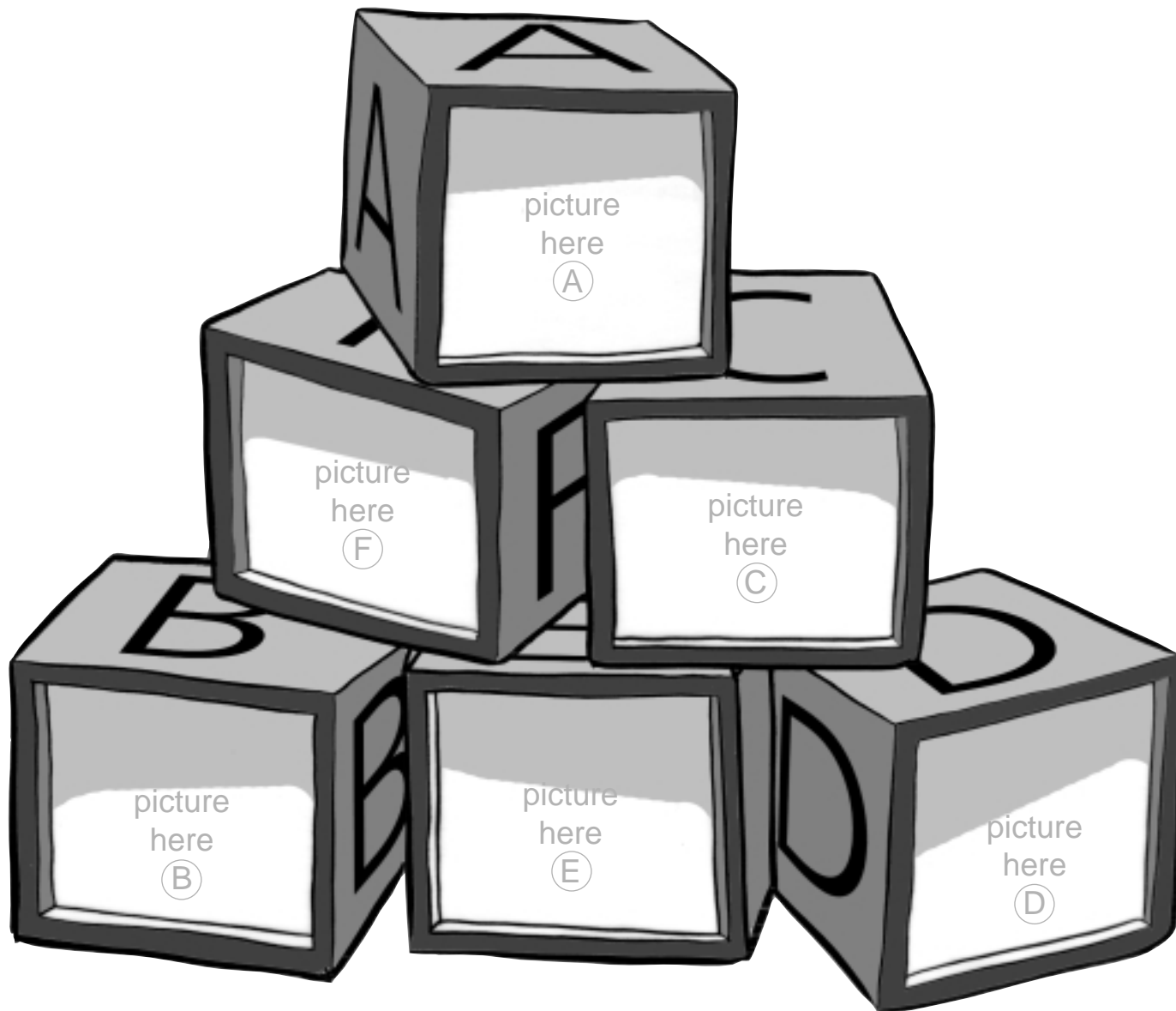

R
E
P
R
O
D
U
C
I
B
L
E
P
A
G
E
E

Supplement/Life Application
1 copy for each child

In the Beginning
Lesson 2

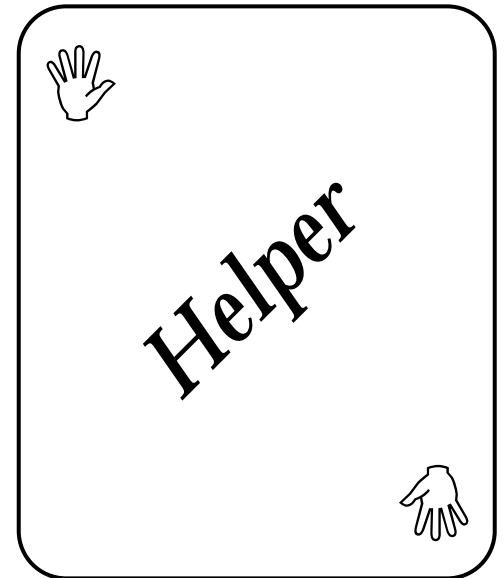
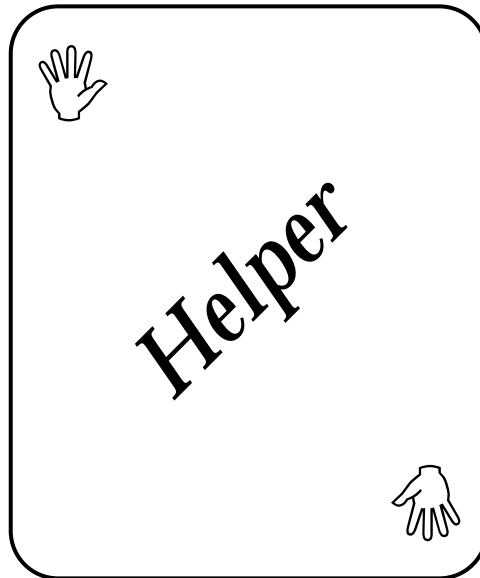
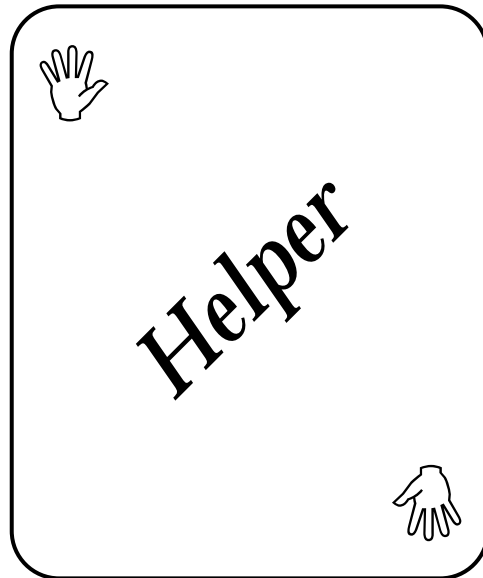
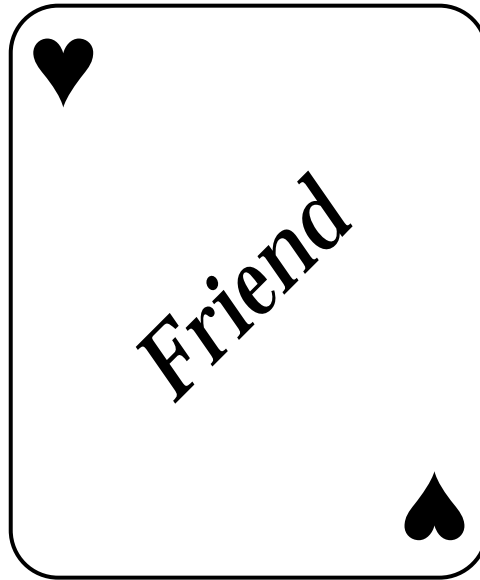

Supplement/Bible Skills

1 copy for each child

Instructions: Trace over the letters.

In the Beginning
Lesson 2

Genesis

2 Samuel

Exodus

1 Kings

Leviticus

2 Kings

Numbers

1 Chronicles

Deuteronomy

2 Chronicles

Joshua

Ezra

Judges

Nehemiah

Ruth

Esther

1 Samuel

