

Sun, Moon and Stars

Creation 1
Lesson 3

Lesson Objectives

- The children will identify the sun, moon and stars.
- The children will state that God created the sun, moon and stars.
- The children will thank God for the sun, moon and stars.

Bible Story Text

Genesis 1:14-19

Bible Truth

God made day and night.
(Genesis 1:5)

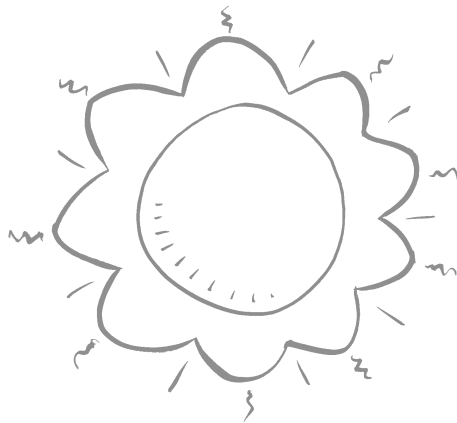

Lesson Plan

Greeting and Registration

Preclass Activity: Preclass Centers

Welcome and Singing

Centers:

Bible Story: God Made the Sun, Moon and Stars

Life Application: Creation Concentration

Craft: Sunshine Necklace

NOTE: Reopen preclass centers during check out.
Be sure to allow sufficient time for a snack.

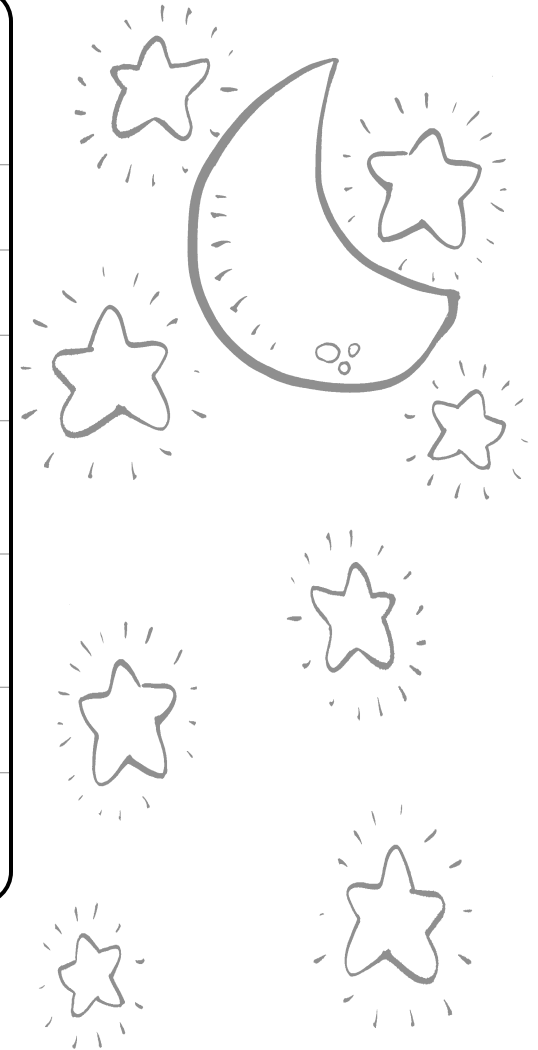

Sun, Moon and Stars

Preclass Centers

As the children arrive, guide them to a preclass center. Have no more than six children at each center.

Materials

Use the materials previously selected for this unit's preclass centers.

Preparation

1. Be sure to check the condition of the materials selected for this unit's preclass centers prior to set up. Replace any broken toys, or puzzles with missing pieces, as necessary.
2. Set up the centers before the children come into the classroom.
3. Assign a teacher to each center and have the teachers stay in those centers until the singing begins.

Instructions

Guide the play in your center reinforcing the unit theme.

Teacher Tips

- **IMPORTANT:** Do not allow any small toys in the classroom. First check all toys for size. You can obtain a "safety cylinder" from a pediatrician. Any object that can fit into the cylinder is too small and could cause a child to choke.
- Be involved in the group play and offer guidance as needed.
- Wear comfortable clothes suitable for sitting on the floor.
- Smile! Be childlike in heart and alert in mind.

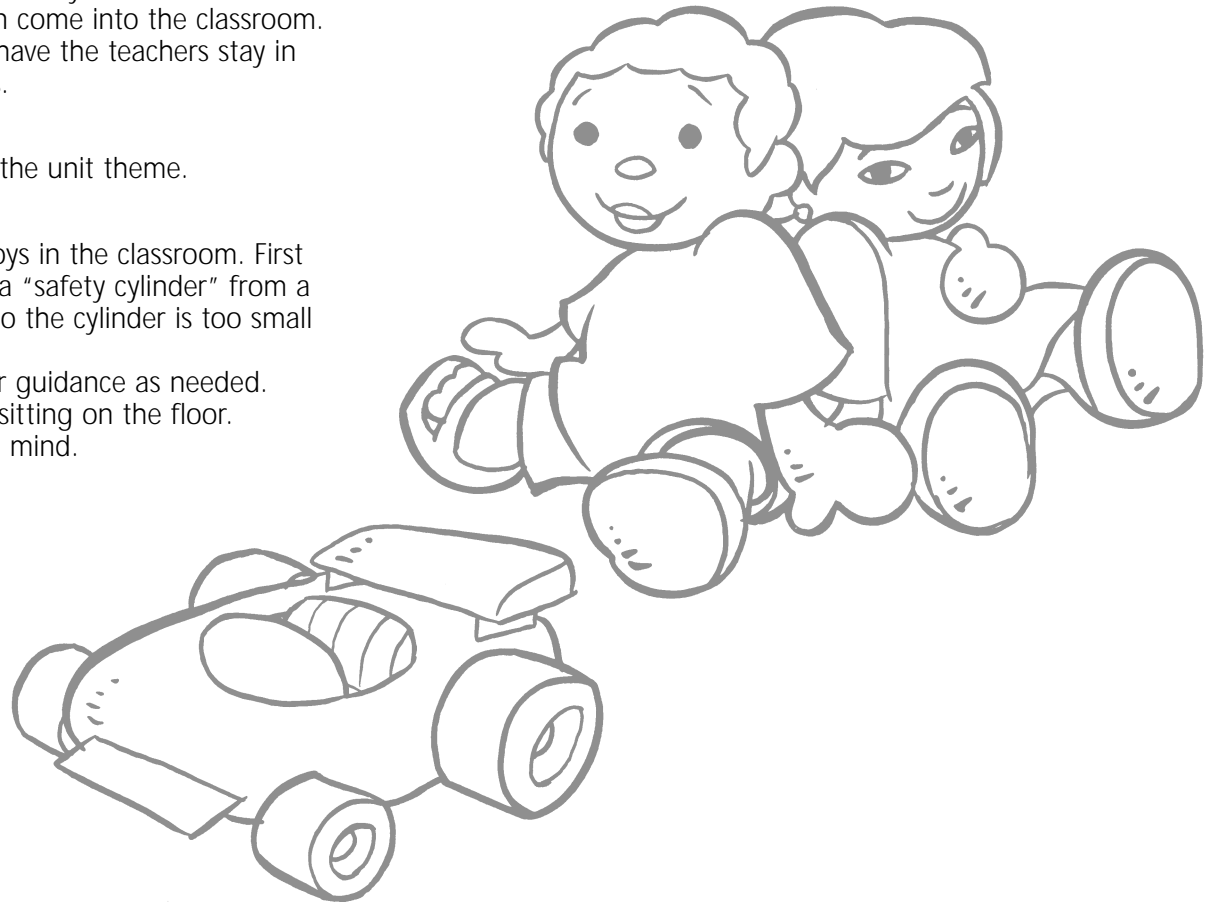

Sun, Moon and Stars

God Made the Sun, Moon and Stars

This lesson emphasizes the sun, moon and stars.

Bible Story Text

Genesis 1:14-19

Materials

For the teacher:

- Bible
- scissors
- flannel board with light blue background
- felt: black, yellow and white (can be purchased at a craft store)
- glitter (optional)
- two-sided tape
- tape

Preparation

1. If you do not have a flannel board, one can easily be made with a piece of foam board, purchased at a craft, office or art supply store. Cut the board to approximately 11" x 17". Cover the board with a piece of light blue flannel or felt, overlapping the material and taping with two-sided tape on the back.
2. Cut the following felt pieces for the board:
 - A. yellow circle for the sun
 - B. white cloud shapes
 - C. white crescent for the moon
 - D. white star shapes (one for each child)
3. Cut the black felt to the exact size of the board and lay it over the board.
4. Tape the top of the black felt to the top edge of the board so that it can be lifted and flipped over the top.
5. Practice telling the story with the flannel board so that you are confident and animated, and can give the children your full attention.

Sun, Moon and Stars

Have a Bible open in front of you. Prop or hold the flannel board so that all the children can see it. Have the black felt cover the board. See Figure A.

What do you see on the board? That's right, NOTHING! Is it light or dark? Yes, it is dark. Hold up the Bible, opened to Genesis.

The Bible tells us that once it was very dark. There was no blue sky or bright sun. Do you see any trees? Do you see any flowers? No! Everything was dark. Say the next line slowly and softly. Then the Bible says that God made the world. Close your eyes and listen!

God said, "Let there be light" and "Let there be sky." Remove the black felt from the front of the board. Open your eyes. God made the blue sky! God put the sun in the sky in the daytime. Place the yellow sun on the board as shown in Figure B.

Sometimes we see clouds in the sky. Have you seen clouds in the sky? Place the white felt clouds on the board. See Figure C.

God made the day and he made the night. Put the black felt back over the board. What do we see in the sky at night? Place the white crescent moon on the black felt, as shown in Figure D. That's right, we see the moon. Sing the first four verses of the "Creation Song" from the Unit 1 Song Sheet.

What else did God put in the sky? Let each child place a star on the board. See Figure E. Yes, God put stars in the sky. Sing the song "Twinkle, Twinkle Little Star" from the Unit 1 Song Sheet. God made the day and the night. Can you say that with me? God made day and night. He made the sun and the moon and the stars.

Conclusion

Repeat the story, having the children add the pieces to the flannel board. Repeat the songs also. As "Twinkle, Twinkle Little Star" is sung, each child can add a star to the sky.

Finish by having the children thank God for the day, night, sky, clouds, sun, moon and stars. Have them repeat the Bible truth together: *God made day and night.*

Teacher Tips

- Be very animated as you tell the Bible story. Use short concise sentences. You will keep the children's attention better this way.
- You can glue a small sprinkling of glitter on the stars.



Sun, Moon and Stars

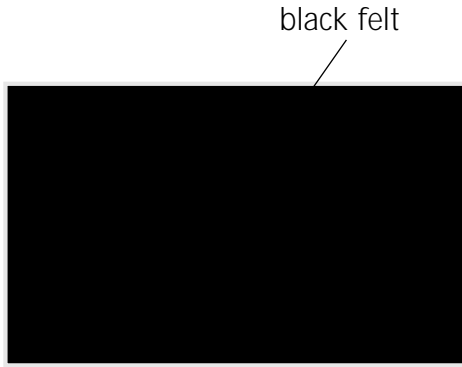
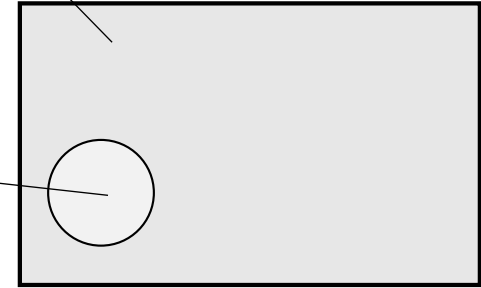

Figure A

light blue flannel board



sun

Figure B

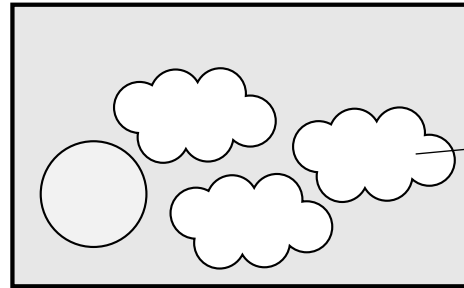

clouds

Figure C

black felt

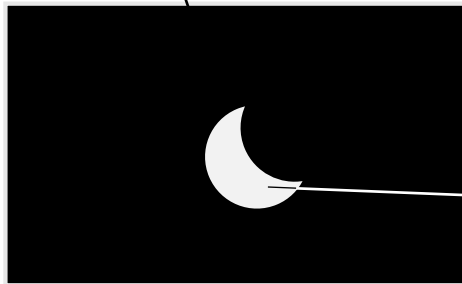

white crescent moon

Figure D

stars

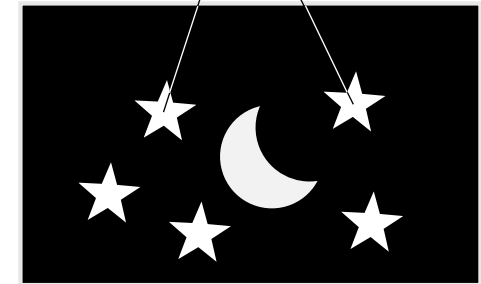

Figure E



Sun, Moon and Stars

Creation Concentration

Through this card game, the children will identify and state aspects of God's creation: day, night, sun, moon, stars, sky, white and dark clouds.

Bible Truth

God made day and night. (Genesis 1:5)

Materials

For the teacher:

- 16 unlined index cards, 3" x 5" (or cards of that size made from poster board)
- scissors
- markers
- laminate or clear contact paper (can be found at a department store)

Reproducible Pages:

- Page A, 2 copies for the teacher

Preparation

1. Prepare five sets of matching cards as follows:
 - A. From the copies of Reproducible Page A, cut out two of each image.
 - B. Color each set of each images identically.
 - C. Glue each image onto a 3" x 5" card.
2. Prepare the remaining three sets.
 - A. Using the remaining blank index cards, color on one side only, as indicated below:
 - B. Color two yellow for day or light.
 - C. Color two black for night or dark.
 - D. Color two blue for sky.

Instructions

1. Divide the children into age groups: twos and threes.
2. For the twos, play the game as detailed below:
 - A. Show the children one card of each pair and let them tell you what it is. This will help them to recognize the cards during the game.
 - B. Give the children each a card and put the match to their cards on the floor or table, face up. Each child's card will match a card laid out.

- C. Ask each child, *Can you find the match to your card?* If they need help you might say, *I see you have a picture of the sun. Where is the other picture of the sun?* When they find the match, let them hold the pair.
 - D. Say, *Who made the sun? God made the sun.* Encourage the children to repeat the answer with you.
 - E. The game is over when all cards are picked up. If there is time, play again.
3. For the threes, play the game as detailed below:
 - A. Show the children one card of each pair and let them tell you what it is. This will help them to recognize the cards during the game.
 - B. Put all the cards face down and mix them up.
 - C. Let each child take a turn flipping over two cards. If there is a match, the child holds the pair.
 - D. Say, *I see you picked up a sun. Who made the sun? God made the sun.* Encourage the older children to repeat the answer with you.
 - E. The game is over when all cards are picked up. If there is time, play again.

Bible Truth Activity

Ask children, *Who made day and night? God did! Who made the clouds? God did! Who made the sun, moon and stars? God did! Let's say together, God made day and night.*

Conclusion

Sing the first two days of the "Creation Song" from the Unit 1 Song Sheet. *Let's thank God for making day and night. Thank you God for making day and night. Amen.*

Who are you going to tell about Bible class today? What are you going to tell them? That God made the sun? Good.

Teacher Tips

- The cards will last a long time if you laminate or cover them with clear contact paper.
- These cards are useful if you need an activity to fill time or if you have a child who needs some extra attention or is not participating well in a group activity.

God Made Day and Night.



Sun, Moon and Stars

Sunshine Necklace

This craft will help the child recognize that God made the sun and appreciate the beauty of God's creation.

Materials

For each child:

- 1 orange, yellow or gold small paper plate, 6" diameter.
- construction paper: yellow, orange
- yarn or ribbon, 20"
- glue stick

For the teacher:

- scissors
- black permanent marker
- single hole punch

Preparation

1. Cut yellow and orange construction paper into 13 small strips approximately $1\frac{1}{2}$ " x 4" for each child.
2. Cut out a $4\frac{1}{2}$ " circle from yellow construction paper for each child.
3. Write "God Made the Sun" on each yellow circle.
4. Punch two holes in the top of each plate, about 3" apart to string the yarn through. See Figure A.
5. Make a model of the necklace following the instructions.

Instructions

1. Show the children your model of the Sunshine Necklace.
2. Give them each a paper plate and the paper strips.
3. Help the children glue their paper strips around the inside rim of their plates so that the strips hang over the edge. See Figure A.
4. Give them each a yellow circle and help them glue it in the center of the paper plates and over the ends of the paper strips. See Figure B.
5. Thread the yarn through the holes. See Figure C. Tie them together to form a necklace.
6. Write the children's names on the back of their plates.

Conclusion

Talk with the children about how we need the sun to keep us warm and give us light. Explain that the sunshine makes us happy and how God shows us his love by giving us the sun. Let children wear their necklaces home to remind them that God made the sun.

Teacher Tips

- Be sure to use short concise sentences so the children will understand you more clearly.
- You can cut the strips more easily by stacking the paper in a pile before cutting it.



Sun, Moon and Stars

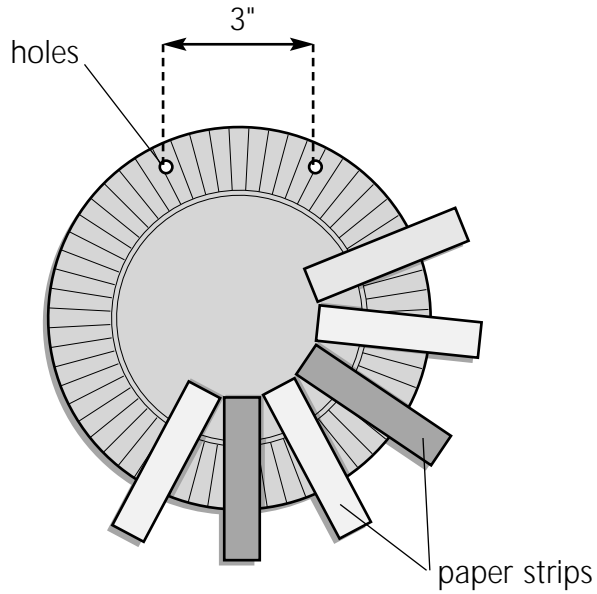

Figure A

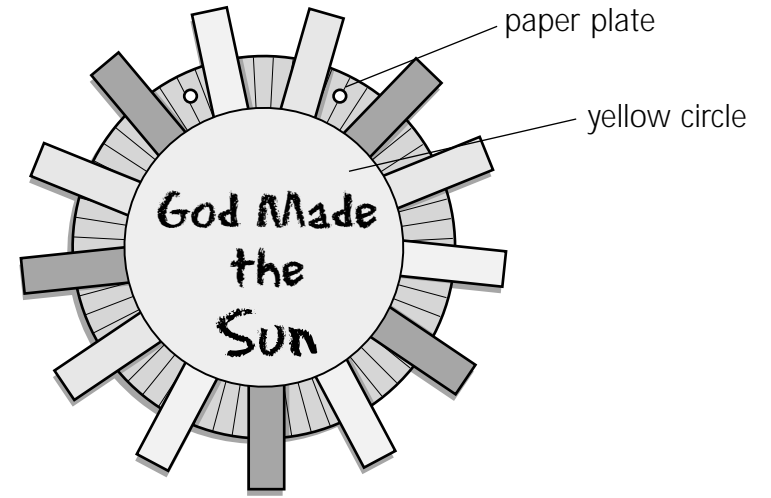

Figure B

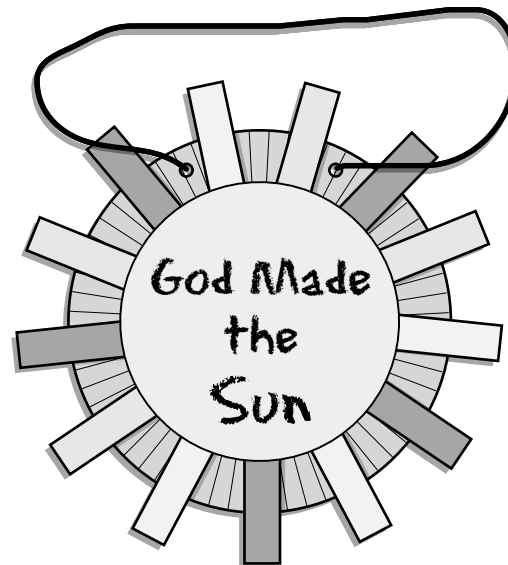

Figure C



Sun, Moon and Stars

Creation 1 Lesson 3

Lesson Objectives

- The children will identify the sun, moon and stars.
- The children will state that God created the sun, moon and stars.
- The children will thank God for the sun, moon and stars.

Bible Story Text

Genesis 1:14-19

Bible Truth

God made day and night. (Genesis 1:5)

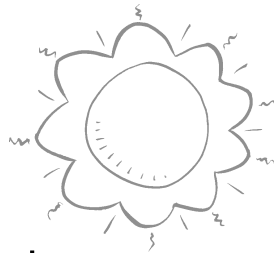

Preclass Centers

As the children arrive, guide them to a pre-class center. Have no more than six children at each center.

Materials

Use the materials previously selected for this unit's preclass centers.

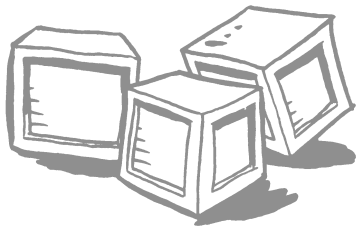

Lesson Plan

Greeting and Registration

Preclass Activity: Preclass Centers

Welcome and Singing

Centers:

Life Application: What Do I Do at Night? In the Morning?

Bible Story: God Made the Sun, Moon and Stars

Craft: Paper Sun

NOTE: Reopen preclass centers during check out. Be sure to allow sufficient time for a snack.

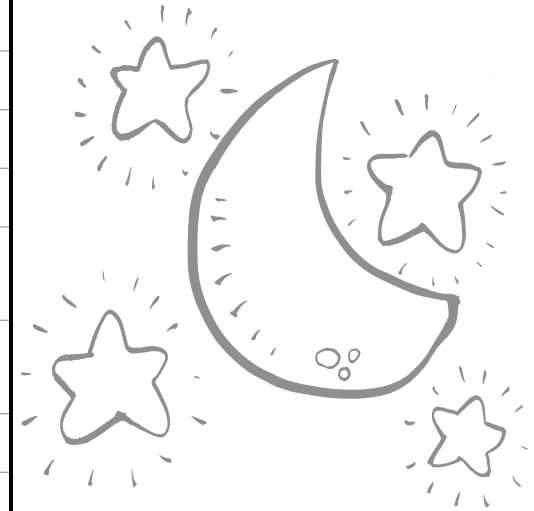

Preparation

1. Be sure to check the condition of the materials selected for this unit's preclass centers prior to set up. Replace any broken toys, or puzzles with missing pieces, as necessary.
2. Set up the centers before the children come into the classroom.
3. Assign a teacher to each center and have the teachers stay in those centers until the singing begins.

Instructions

Guide the play in your center reinforcing the unit theme.

Teacher Tips

- **IMPORTANT:** Do not allow any small toys in the classroom. First check all toys for size. You can obtain a "safety cylinder" from a pediatrician. Any object that can fit into the cylinder is too small and could cause a child to choke.
- Be involved in the group play and offer guidance as needed.
- Wear comfortable clothes suitable for sitting on the floor.
- Smile! Be childlike in heart and alert in mind.

Life

Application

What Do I Do at Night? In the Morning?

The children will enjoy pretending to do routine nighttime activities and routine daytime activities. They will distinguish between the two routines and learn that God is with them at night and in the morning.

Bible Truth

God made day and night. (Genesis 1:5)

Materials

For each child:

- dry washcloth or baby wipe
- small paper cup
- small portion of dry cereal

For the teacher:

- age-appropriate Bible story
- Bible
- hand mirror
- construction paper or poster board for a sun and a moon
- scissors

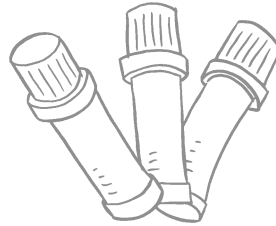

Preparation

Make a sun and a moon. Make these large enough, approximately 12", so all the children in the center can see them.

What Do I Do at Night?

Tell the children that you are going to play a game of pretend. Hold up the moon and say to the children, *It is night now. Mommy says, "Time to pick up toys."* Have children pretend to put toys away. *We obey our families when they tell us it is time to put away our toys. OK, we're putting our toys away!*

Let's have a story from the Bible before we go to sleep. Read the short Bible story. *Now it is time for a prayer.* Say a short prayer.

OK! Time for bed. Hug each child and pretend to cover them. *It is time to turn out the light, I know that God is with me all of the time. God takes care of us while we are sleeping. Good night!* Let the children pretend to sleep for a few seconds.

What Do I Do in the Morning?

Hold up the sun. *Time to wake up! Good morning! Good morning!* Have the children yawn, stretch, hug each other. *It is time to get up.*

Is it day or night now? It is day! God made the night, and God also made the day!

Let's get dressed. Have children pretend to put on clothes. *Let's comb our hair.* Have them pretend to comb their hair. Hold the hand mirror to each child. *You look very pretty/handsome today!* *Time to brush our teeth.* Have children pretend to open toothpaste and squeeze onto toothbrush; then brush teeth with finger.

Breakfast time. Sit on floor around a pretend table and give each child a small cup of dry cereal. Say a short prayer. Have children eat the cereal.

Ask the children. *Who is with you today? (God) Open the Bible. It is time to read the Bible. Does someone in your family read the Bible in the morning? This is called a quiet time, or time with God.* Read one verse or phrase out of the Bible, for example: "Love one another." *When you or someone in your family is reading the Bible, are you quiet? Do you wait for them to finish? We love the Bible. It is God's special book to tell us how to be happy! The Bible tells us that God made the day and he made the night. Can you say that with me? Repeat the phrase together. All right, time to go to work and school. I love you! Have a great day! Hug and pretend to leave together.*

Bible Truth Activity

Who made the day? That's right, God did! Who made the night? Yes, God did! God made day and night.

Conclusion

Let's thank God for making the day and the night. Thank you, God, for making the day and the night. Amen.

Who are you going to tell about Bible class today? What are you going to tell them you have learned? That God made the night? That's good. God did make the night.

Teacher Tips

- IMPORTANT: Get the parents' permission to give the child cereal. A child may have food allergies, special dietary concerns, etc.
- You can use as many or as few of the props as you like. Anything you don't have, you can pretend.

God Made the Sun, Moon and Stars

This lesson emphasizes the sun, moon and stars.

Bible Story Text

Genesis 1:14-19

Materials

For the teacher:

- Bible
- scissors
- flannel board with light blue background
- felt: black, yellow and white (can be purchased at a craft store)
- glitter (optional)
- tape



Preparation

1. If you do not have a flannel board, one can easily be made with a piece of foam board, purchased at a craft, office or art supply store. Cut the board to approximately 11" x 17". Cover the board with a piece of light blue flannel or felt, overlapping the material and taping with two-sided tape on the back.
2. Cut felt pieces for the board:
 - A. yellow circle for the sun;
 - B. white cloud shapes;
 - C. white crescent for the moon;
 - D. white star shapes (one for each child).
3. Cut the black felt to the exact size of the board and lay it over the board.
4. Tape the top of the black felt to the top edge of the board so that it can be lifted and flipped over.
5. Practice telling the story with the flannel board so that you are confident and animated and can give the children your full attention.

Sun, Moon and Stars

Have a Bible open in front of you. Prop or hold the flannel board so that all the children can see it. Have the black felt covering the board. See Figure A.

What do you see on the board? That's right, NOTHING! Is it light or dark? Yes, it is dark. Hold up the Bible, opened to Genesis. The Bible tells us that once it was very dark. There was no blue sky

or bright sun. Do you see any trees? Do you see any flowers? NO! Everything was dark. Say the next line slowly and softly. Then the Bible says that God made the world. Close your eyes and listen!

God said, "Let there be light," and "Let there be sky." Remove the black felt from the front of the board. Open your eyes. God made the blue sky! God put the sun in the sky in the daytime. Place the yellow sun on the board as shown in Figure B.

Sometimes we see clouds in the sky. Have you seen clouds in the sky? Place the white felt clouds on the board. See Figure C.

God made the day and he made the night. Put the black felt back over the board. What do we see in the sky at night? Place the white crescent moon on the black felt, as shown in Figure D. That's right, we see the moon. Sing the first four verses of the "Creation Song" from the Unit 1 Song Sheet.

What else did God put in the sky? Let each child place a star on the board. See Figure E. Yes, God put stars in the sky. Sing the song "Twinkle, Twinkle Little Star" from the Unit 1 Song Sheet. God made the day and the night. Can you say that with me? God made day and night. He made the sun and the moon and the stars.

Conclusion

Repeat the story, having the children add the pieces to the flannel board. Repeat the songs also. As "Twinkle, Twinkle Little Star" is sung each child can add a star to the sky.

Finish by having the children thank God for the day, night, sky, clouds, sun, moon and stars. Have them repeat the Bible truth together: *God made day and night.*

Teacher Tips

- Be very animated as you tell the Bible story. Use short concise sentences. You will keep their attention better this way.
- You can glue a small sprinkling of glitter on the stars.

Sun, Moon and Stars

Bible Story

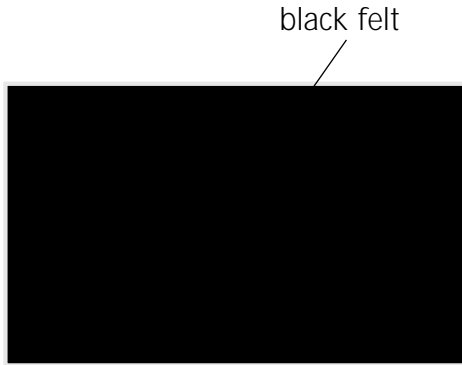

Figure A

light blue flannel board

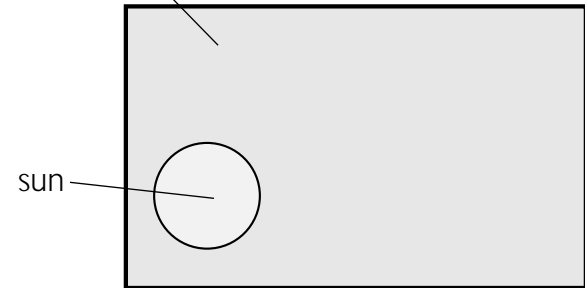

Figure B

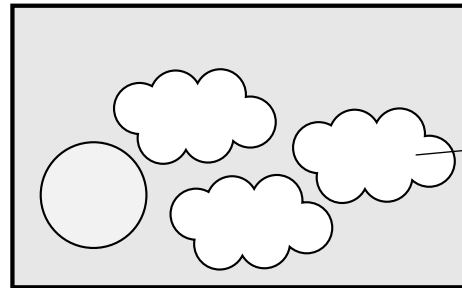

Figure C

black felt

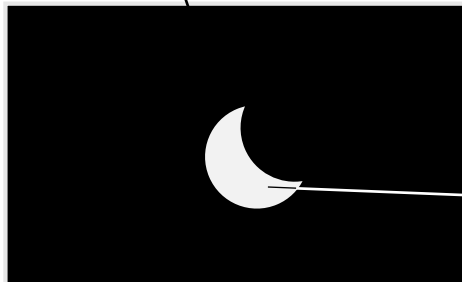

Figure D

stars

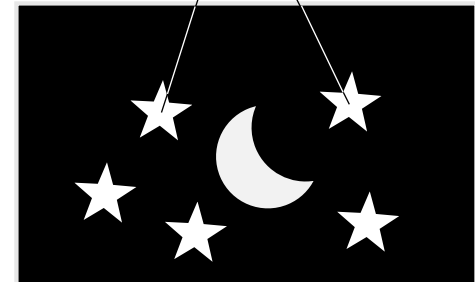

Figure E



Paper Sun

This craft will help the child identify the sun and reinforce the truth that God made the sun.

Materials

For each child:

- 1 sheet yellow construction paper
- 1/8 sheet yellow tissue paper
- white or light blue construction paper
- glue stick

For the teacher:

- scissors
- black marker

Preparation

1. Cut a 4" circle from yellow tissue paper for each child.
2. Cut a 5" circle from yellow construction paper for each child.
3. Cut seven 2" triangles from yellow construction paper for each child.
4. Across the bottom of each piece of white construction paper write "God Made the Sun."
5. Make a model of the craft following the instructions.

Instructions

1. Show a sample of the finished craft.
2. Give the children each a sheet of white construction paper and a yellow paper circle.
3. Help them glue their yellow paper circles onto the white papers. See Figure A.
4. Give them each a yellow tissue paper circle. Help them glue the tissue paper circle onto their paper circles. See Figure B.
5. Give them each seven triangles and help them glue these around the circles to make "rays of the sun." See Figure B.
6. Write the children's names on their crafts.

Conclusion

Remind the children of the Bible Truth, God made day and night. Talk about the sun: what it looks like, how it gives us light, how it makes us warm. Remind the children that God takes care of us by giving us the sun.

Teacher Tips

- Have the children help you clean the craft area. They will enjoy helping.

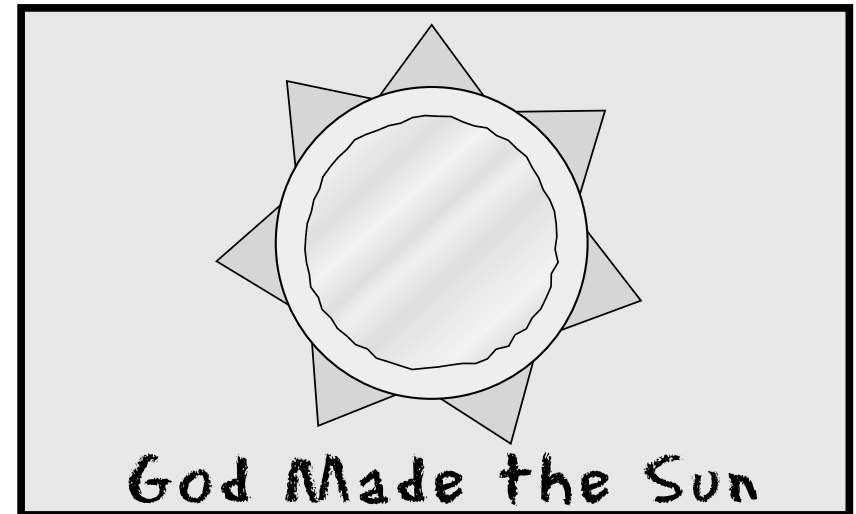

craft

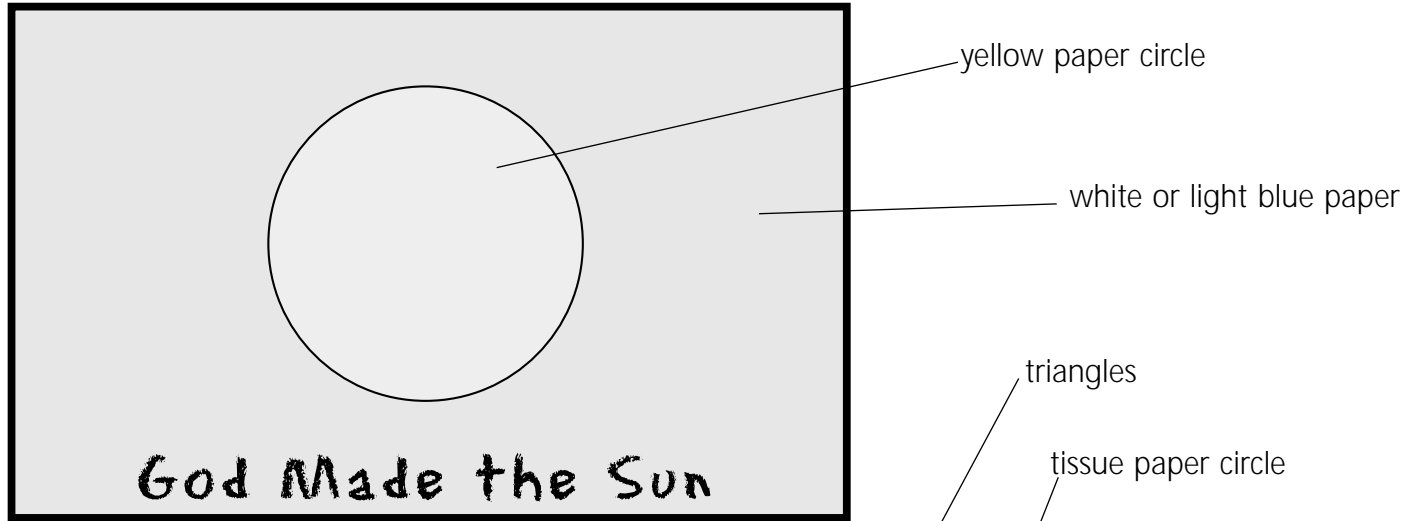

Figure A

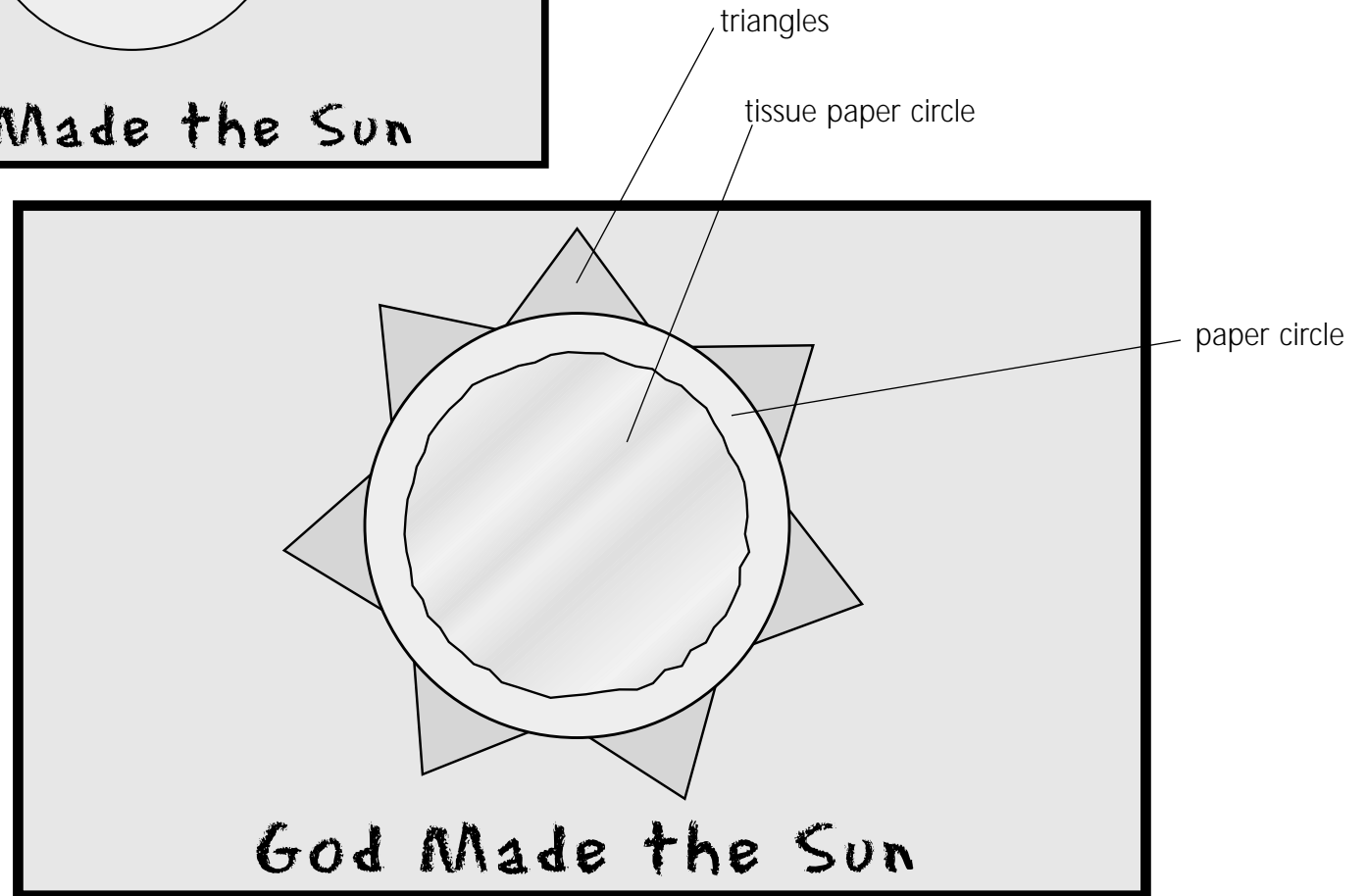
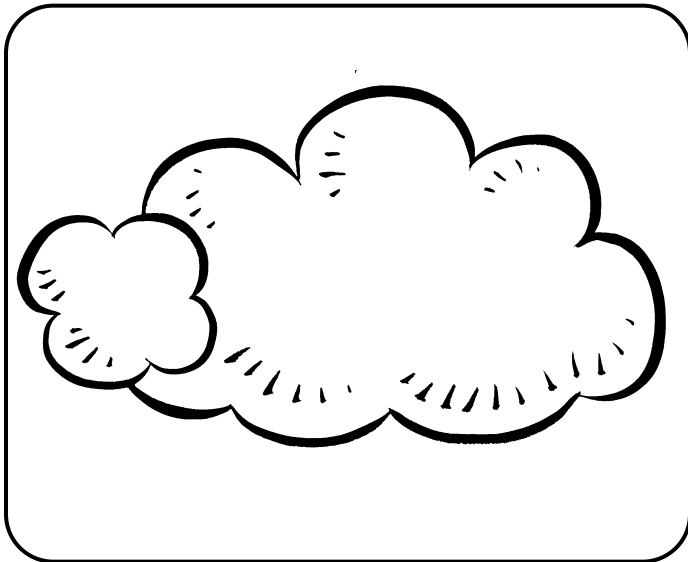
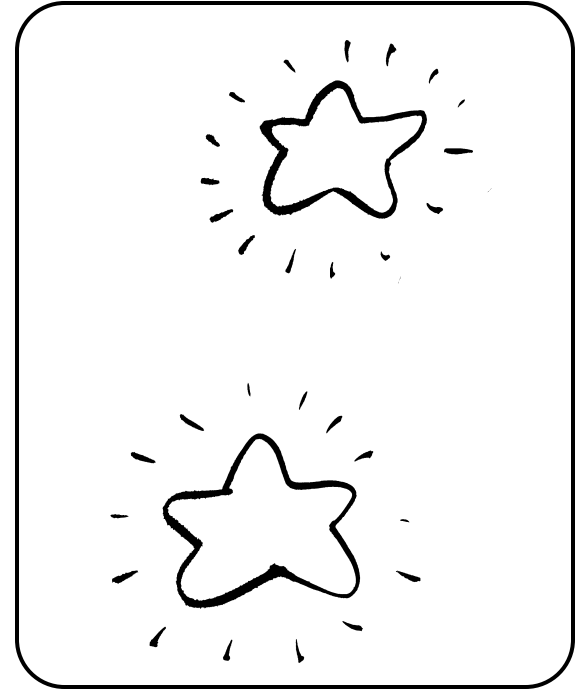
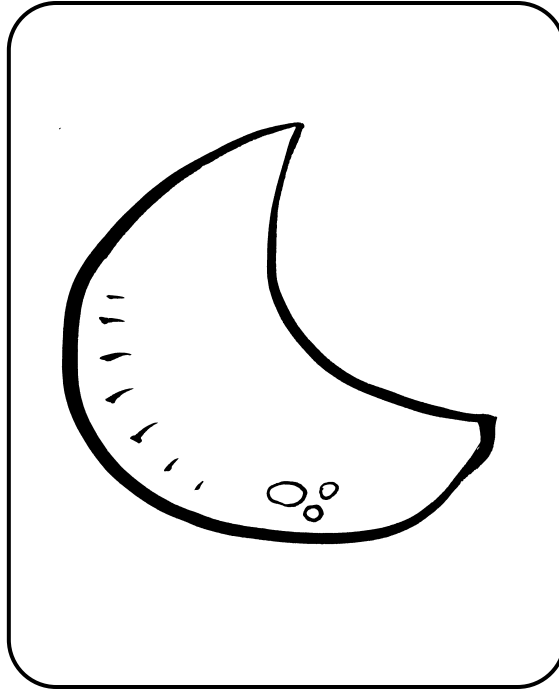
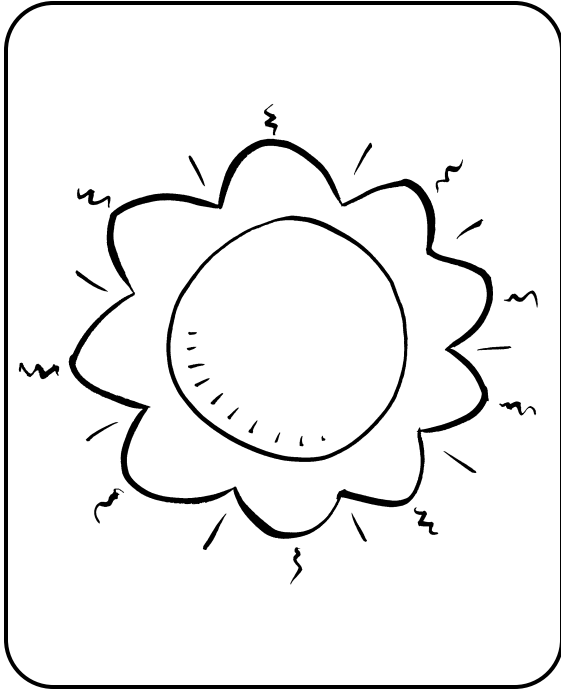

Figure B





A
B
C
D
E
F
G
H
I
J
K
L
M
N
O
P
Q
R
S
T
U
V
W
X
Y
Z



Creation
Concentration
Cards

