

Day and Night

Lesson Objectives

- The children will identify light, dark, day and night.
- The children will state that God created light, dark, day and night.
- The children will thank God for day and night.

Bible Story Text

Genesis 1:1-8, 14-19

Bible Truth

God made day and night.
(Genesis 1:5)



Lesson Plan

Greeting and Registration

Preclass Activity: Preclass Centers

Welcome and Singing

Centers:

Bible Story: God Made Day and Night

Life Application: What Do I Do at Night? In the Morning?

Craft: Day and Night Hat

NOTE: Reopen preclass centers during check out.
Be sure to allow sufficient time for a snack.

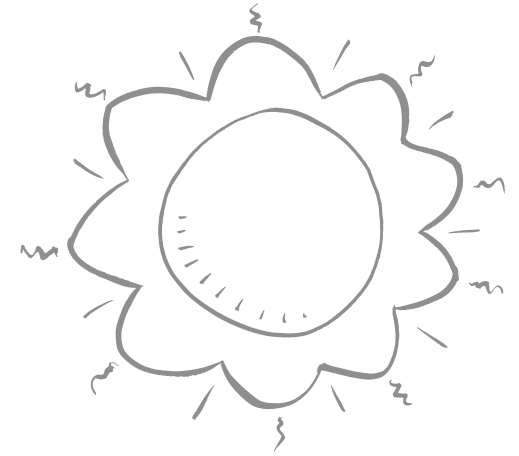

Day and Night

Preclass Centers

In the preclass centers children will use language, motor, and cognitive skills, learn to interact with peers and cooperate in small groups.

Select four centers to use this unit. Assign a teacher to set up and supervise each center with no more than six children.

Materials

IMPORTANT: Do not allow any small toys in the classroom. First check all toys for size. You can obtain a "safety cylinder" from a pediatrician. Any object that can fit into the cylinder is too small and could cause a child to choke.

- Housekeeping Center—2 washable dolls (of diverse ethnicity, i.e., black and white), play food, dishes and 2 small blankets
- Story Center—simple books with limited text (cardboard are the most sturdy and durable) and large pillows
- Block Center—set of large blocks, people, animal figures (plastic or wooden) and toy cars
- Puzzle Center—1 puzzle for each child (for twos each puzzle piece itself should be a complete familiar object, for threes most can complete a 20-piece puzzle). **NOTE:** A puzzle should have all the pieces. If a puzzle piece is lost, the entire puzzle should be thrown out.

Instructions

Guide the play in each center reinforcing the unit theme. Refer to the following example for help in directing play and asking relevant questions.

In the Housekeeping Center, ask the children: *What are you cooking? Is that breakfast or lunch? When do we eat breakfast? That's right, in the morning. Are you putting the baby to bed? It must be nighttime. What do you see in the sky at night? Who made the day and night? That's right. God made the day and night.*

Teacher Tips

- You may want to try other centers such as transportation, large motor or manipulative.
- Wear comfortable clothes suitable for sitting on the floor.



Day and Night

God Made Day and Night

This story emphasizes God's creation of day and night.

Bible Story Text

Genesis 1:1-8, 14-19

Materials

For each child:

- 1 star sticker

For the teacher:

- Bible
- construction paper: 1 sheet each of blue, white and yellow; 2 sheets of black
- scissors
- 6 large craft sticks
- 6 small paper plates
- glue or stapler
- extra star stickers

Reproducible Pages:

- Page A, 1 copy for the teacher
- Page B, 1 copy for the teacher

Preparation

1. Prepare the Bible Story Pictures.
 - A. Use the blank sheet of black construction for Picture 1.
 - B. Prepare Picture 2 as follows:
 - 1) Cut a sun out of yellow construction paper.
 - 2) Glue the sun onto the blue paper.
 - C. Prepare Picture 3 as follows:
 - 1) Cut a moon out of the white construction paper.
 - 2) Glue the moon onto the second sheet of black paper.
2. Prepare the Plate Pictures.
 - A. Make Plate 1 and Plate 2 as follows:
 - 1) Glue or staple a paper plate to each stick.
 - 2) Cut out the images from the copies of Reproducible Pages A and B.
 - 3) Color these pictures with bright markers.
 - 4) Glue each picture to a paper plate.

B. Make Plate 3 as follows:

- 1) Glue or staple a paper plate to a stick.
- 2) Cut out a blue circle and two white clouds from construction paper.
- 3) Glue the clouds to the blue circle.
- 4) Glue the blue circle to a paper plate.

C. Make Plate 4 as follows.

- 1) Glue or staple a paper plate to a stick.
- 2) Cut a yellow sun out of construction paper.
- 3) Glue the sun to a paper plate.

D. Make Plate 5 as follows.

- 1) Glue or staple a paper plate to a stick.
- 2) Cut a white moon and a black circle out of construction paper.
- 3) Glue the moon to the black circle.
- 4) Glue the black circle to a paper plate.

E. Make Plate 6 as follows.

- 1) Glue or staple a paper plate to a stick.
- 2) Cut a black circle out of construction paper and place star stickers on it.
- 3) Glue the black circle to a paper plate.



Day and Night

Creation 1

Lesson 1

Day and Night

Put your hands over your eyes, like this. Demonstrate this motion. What do you see? That's right, NOTHING! Is it light or dark? Yes, it is dark. Open your Bible to Genesis. The Bible tells us that once it was very dark. There was no blue sky or bright sun.

Hold up Picture 1. Do you see any trees? Do you see any flowers? No! Everything was dark. Then the Bible says that God made the world. Say this next line slowly and softly, with emphasis. God said: "Let there be light" and "Let there be sky."

Hold up Picture 2. God put the sun in the sky in the daytime. Sometimes we can see the stars in the sky at night.

Hold up Picture 3. Let's put stars in the sky! Let each child place a star sticker on Picture 3. God made the twinkling stars, too.

God made the day and night, and God made the beautiful world we live in! Sing the first day of the "Creation Song" from the Unit 1 Song Sheet, while each child holds up one finger.



Conclusion

Remember what the Bible says that God made?

Hold up Plate 1. God made the daytime, when we wake up.

Hold up Plate 2. God made the nighttime, when we go to sleep.

Hold up Plate 3. What else did God make? That's right, he made the clouds in the sky, and he made the sky. Hold up Plate 4. Look at this. God made the sun. Hold up Plate 5. God made the moon.

What else did God make? Hold up Plate 6. God made the stars.

Let each child hold a plate and tell what God made. Let's thank God for making all of these things. Let each child thank God for the things he has made, using the Plate Pictures to prompt them. Sing the "Creation Song" again if there is time.

Teacher Tips

- Speak slowly and in short sentences to twos and threes. They will understand more and will be more obedient when they have clear simple expectations.
- The lead teacher should keep the pictures and stick props to use in subsequent lessons.
- Practice telling the story with the pictures and props so that you are confident and animated and can give the children your full attention.

Day and Night

What Do I Do at Night? In the Morning?

The children will enjoy pretending to do routine nighttime activities and routine daytime activities. They will distinguish between the two routines and learn that God is with them at night and in the morning.

Bible Truth

God made day and night. (Genesis 1:5)

Materials

For each child:

- dry washcloth or baby wipe
- small paper cup
- small portion of dry cereal

For the teacher:

- age-appropriate Bible story
- Bible
- hand mirror
- construction paper or poster board for a sun and a moon
- scissors

Preparation

Make a sun and a moon. Make these large enough, approximately 12", so all the children in the center can see them.

What Do I Do at Night?

Tell the children that you are going to play a game of pretend. Hold up the moon and say to the children, *It is night now. Mommy says, "Time to pick up toys."* Have children pretend to put toys away. *We obey our families when they tell us it is time to put away our toys. OK, we're putting our toys away!*

Let's have a story from the Bible before we go to sleep. Read the short Bible story. *Now it is time for a prayer.* Say a short prayer.

OK! Time for bed. Hug each child and pretend to cover them. *It is time to turn out the light, I know that God is with me all of the time. God takes care of us while we are sleeping. Good night!* Let the children pretend to sleep for a few seconds.

What Do I Do in the Morning?

Hold up the sun. *Time to wake up! Good morning! Good morning!* Have the children yawn, stretch, hug each other. *It is time to get up.*

Is it day or night now? It is day! God made the night, and God also made the day!

Let's get dressed. Have children pretend to put on clothes. *Let's comb our hair.* Have them pretend to comb their hair. Hold the hand mirror to each child. *You look very pretty/handsome today! Time to brush our teeth.* Have children pretend to open toothpaste and squeeze onto toothbrush; then brush teeth with finger.

Breakfast time. Sit on floor around a pretend table and give each child a small cup of dry cereal. Say a short prayer. Have children eat the cereal.

Ask the children. *Who is with you today? (God) Open the Bible. It is time to read the Bible. Does someone in your family read the Bible in the morning? This is called a quiet time, or time with God.* Read one verse or phrase out of the Bible, for example: "Love one another." *When you or someone in your family is reading the Bible, are you quiet? Do you wait for them to finish? We love the Bible. It is God's special book to tell us how to be happy! The Bible tells us that God made the day and he made the night. Can you say that with me? Repeat the phrase together. All right, time to go to work and school. I love you! Have a great day! Hug and pretend to leave together.*

Bible Truth Activity

Who made the day? That's right, God did! Who made the night? Yes, God did! God made day and night.

Conclusion

Let's thank God for making the day and the night. Thank you, God, for making the day and the night. Amen.

Who are you going to tell about Bible class today? What are you going to tell them you have learned? That God made the night? That's good. God did make the night.

Teacher Tips

- **IMPORTANT:** Get the parents' permission to give the child cereal. A child may have food allergies, special dietary concerns, etc.
- You can use as many or as few of the props as you like. Anything you don't have, you can pretend.

God Made Day and Night.



Day and Night

Day and Night Hat

This craft will help the child identify day, night, sun, moon and stars. Through conversation the child will learn that God created these things. Wearing the hat will serve as a reminder of the truths learned.

Materials

For each child:

- 1 white paper plate
- 1 piece each of black, white and yellow construction paper
- 5 star stickers
- glue stick

For the teacher:

- scissors
- thin black marker

Preparation

1. Cut the center circle of a paper plate about $\frac{3}{4}$ " of the way around leaving the remaining $\frac{1}{4}$ " still attached. See Figure A.
2. Fold center circle along the dotted line shown in Figure B.
3. Measure and cut black construction paper into a half circle that will cover half the center circle of the plate.
4. Cut out yellow circle for the sun, $2\frac{1}{4}$ " in diameter.
5. Cut out white crescent shaped moon $2\frac{1}{4}$ " in length.
6. Write on front rim of plate, "God made day and night."
7. Make a hat to use as a model following the instructions.

Instructions

1. Show sample of the hat. Explain to them that this is a Day and Night Hat. *Who created day? God did. And who created night? Yes, God created night too!*
2. Give each child one cut paper plate, a sun, a moon and the half circle of black construction paper.
3. Help child glue items onto plate, as shown in Figure C.
 - A. Glue black half-circle on right half of the circle.
 - B. Glue the sun on the left half of the circle.
 - C. Glue the moon and stars onto the black half-circle.
4. Write the child's name on the hat.

Conclusion

Read the Bible Truth to the children. Help them name all the things on their hats that God made.

Teacher Tips

- Speak slowly and in short sentences to the twos and threes. They will understand more and be more obedient when they have clear simple expectations.



Day and Night

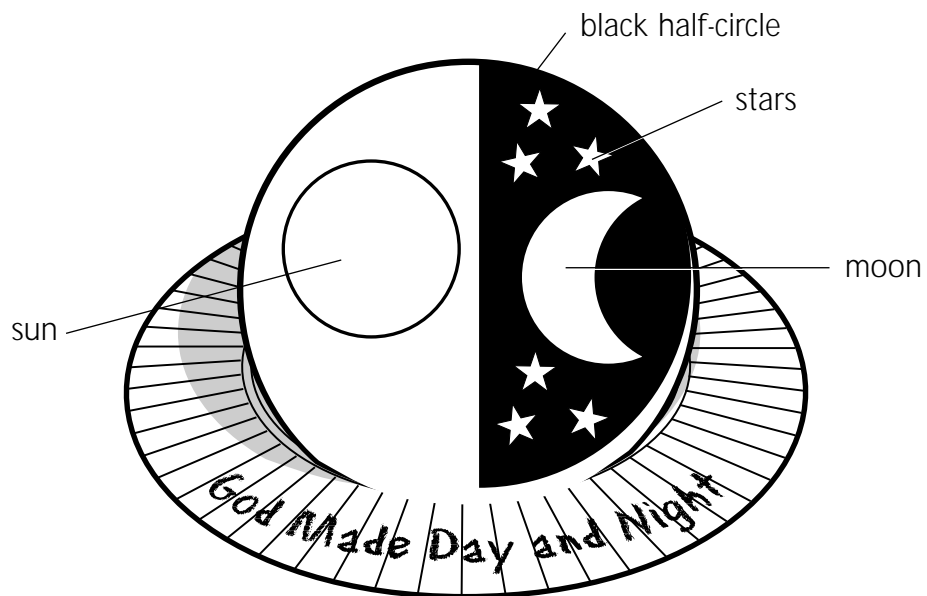
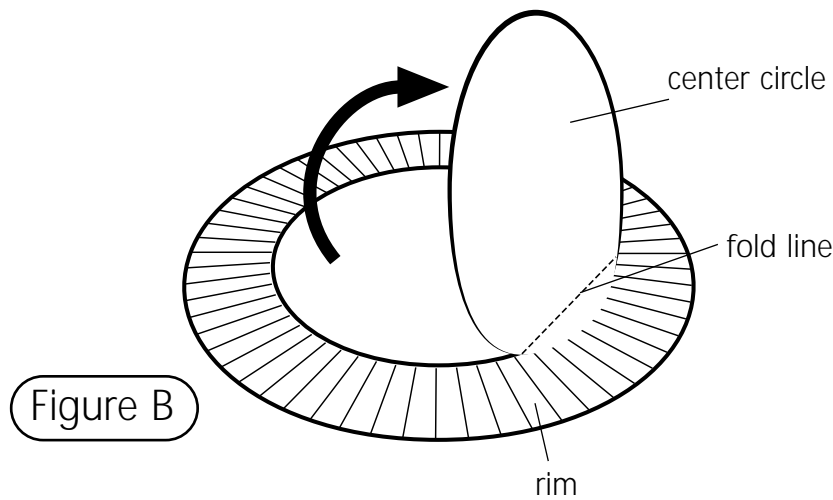
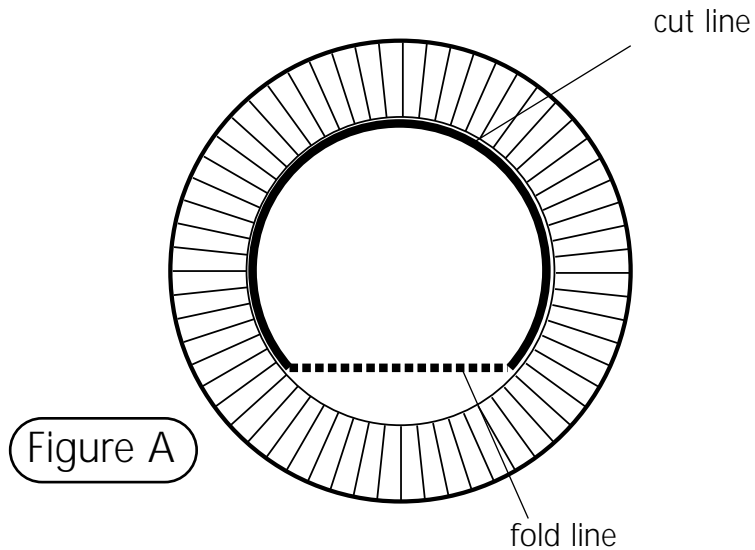

Figure C



Day and Night

Creation 1

Lesson 1

Lesson Objectives

- The children will identify light, dark, day and night.
- The children will state that God created light, dark, day and night.
- The children will thank God for day and night.

Bible Story Text

Genesis 1:1-8, 14-19

Bible Truth

God made day and night. (Genesis 1:5)



Preclass Centers

In the preclass centers children will use language, motor, and cognitive skills, learn to interact with peers and cooperate in small groups.

Select four centers to use this unit. Assign a teacher to set up and supervise each center with no more than six children.

Materials

IMPORTANT: Do not allow any small toys in the classroom. First check all toys for size. You can obtain a "safety cylinder" from a pediatrician. Any object that can fit into the cylinder is too small and could cause a child to choke.

- Housekeeping Center—2 washable dolls (of diverse ethnicity, i.e., black and white),

Lesson Plan

Greeting and Registration

Preclass Activity: Preclass Centers

Welcome and Singing

Centers:

Life Application: Light and Dark

Bible Story: God Made Day and Night

Craft: Day and Night Stick

NOTE: Reopen preclass centers during check out. Be sure to allow sufficient time for a snack.

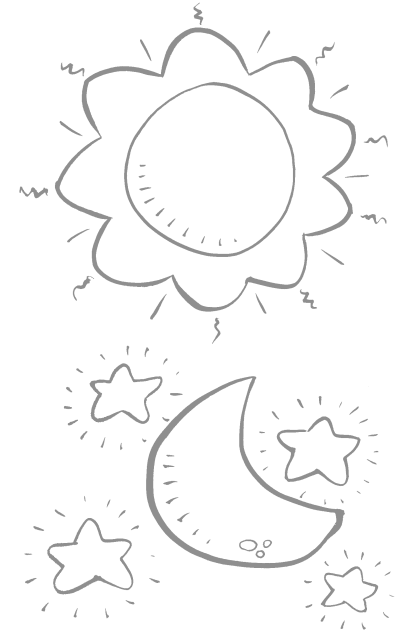

play food, dishes and 2 small blankets

- Story Center—simple books with limited text (cardboard are the most sturdy and durable) and large pillows
- Block Center—set of large blocks, people, animal figures (plastic or wooden) and toy cars
- Puzzle Center—1 puzzle for each child (for twos each puzzle piece itself should be a complete familiar object, for threes most can complete a 20-piece puzzle). NOTE: A puzzle should have all the pieces. If a puzzle piece is lost, the entire puzzle should be thrown out.

Instructions

Guide the play in each center reinforcing

the unit theme. Refer to the following example for help in directing play and asking relevant questions.

In the Housekeeping Center, ask the children: *What are you cooking? Is that breakfast or lunch? When do we eat breakfast? That's right, in the morning. Are you putting the baby to bed? It must be nighttime. What do you see in the sky at night? Who made the day and night? That's right. God made the day and night.*

Teacher Tips

- You may want to try other centers such as transportation, large motor or manipulative.
- Wear comfortable clothes suitable for sitting on the floor.

Light and Dark

The children will use flashlights in a tent to experiment with light and dark.

Bible Truth

God made day and night. (Genesis 1:5)

Materials

For each child:

- 1 lightweight, plastic flashlight with working batteries

For the teacher:

- a dark-colored sheet or blanket
- table or chairs to put the sheet over

Preparation

If you use a table for this activity, ask your facility to provide one ahead of time.

Instructions

1. Drape the sheet over the table to make a tent.
2. Have the children sit in a circle. Explain to them that you are going to play a game inside the tent that you have made. Tell them that the tent is small so they will have to sit very still and listen carefully so that everyone will be safe. Have them crawl with you into the tent.
3. Have the children sit or lie on their backs in the tent. If anyone is afraid, open one side of the tent to let in light.
4. Give each child a flashlight, or share if you only have one.
5. Direct play by asking questions, for example: *Ben, can you shine your light on Sarah's shoelace? Laura, can you shine your light on Nathan's knee? Can everybody shine their lights on the top of the tent? on the floor? Can you shine the light on your chin? on your thumb? on your elbow?*
6. Sing the song, "This Little Light of Mine" from the Unit 1 Song Sheet, while using the flashlights.

Day and Night

Creation 1

Lesson 1

Bible Truth Activity

As you play, repeat, *God made light and dark. Ask children, Who made day and night? That's right! God made day and night.* Repeat together.

Conclusion

Ask children, *Who made light and dark? Who is with us when it is light? God is! Who is with us when it is dark? God is! Who are you going to tell about Bible class today? What are you going to tell them? that God is with you in the dark? Let's thank God for making day and night. Thank you, God, for making day and night.*

Teacher Tips

- The activities can be shortened or lengthened according to your needs. It is important to direct play by asking questions. However, if a child comes up with another idea, for example: "Look, my light can touch yours," recognize the idea and explore it by saying, *You're right! What else can your light touch?*
- If you still have time, you can pretend to be camping in the woods.

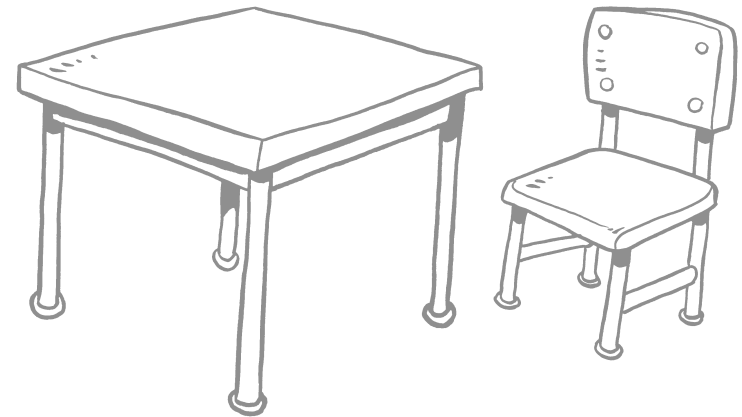

God Made Day and Night

This story emphasizes God's creation of day and night.

Bible Story Text

Genesis 1:1-8, 14-19

Materials

For each child:

- 1 star sticker

For the teacher:

- Bible
- construction paper: 1 sheet each of blue, white and yellow; 2 sheets of black
- scissors
- 6 large craft sticks
- 6 small paper plates
- glue or stapler
- extra star stickers

Reproducible Pages:

- Page A, 1 copy for the teacher
- Page B, 1 copy for the teacher

Preparation

1. Prepare the Bible Story Pictures.
 - A. Use the blank sheet of black construction for Picture 1.
 - B. Prepare Picture 2 as follows:
 - 1) Cut a sun out of yellow construction paper.
 - 2) Glue the sun onto the blue paper.
 - C. Prepare Picture 3 as follows:
 - 1) Cut a moon out of the white construction paper.
 - 2) Glue the moon onto the second sheet of black paper.
2. Prepare the Plate Pictures as follows.
 - A. Make Plate 1 and Plate 2 as follows:
 - 1) Glue or staple a paper plate to each stick.
 - 2) Cut out the images from the copies of Reproducible Pages A and B.
 - 3) Color these pictures with bright markers.
 - 4) Glue each picture to a paper plate.

Day and Night

Creation 1

Lesson 1

- B. Make Plate 3 as follows:
 - 1) Glue or staple a paper plate to a stick.
 - 2) Cut out a blue circle and 2 white clouds from construction paper.
 - 3) Glue the clouds to the blue circle.
 - 4) Glue the blue circle to a paper plate.
- C. Make Plate 4 as follows:
 - 1) Glue or staple a paper plate to a stick.
 - 2) Cut a yellow sun out of construction paper.
 - 3) Glue the sun to a paper plate.
- D. Make Plate 5 as follows:
 - 1) Glue or staple a paper plate to a stick.
 - 2) Cut a white moon and a black circle out of construction paper.
 - 3) Glue the moon to the black circle.
 - 4) Glue the black circle to a paper plate.
- E. Make Plate 6 as follows:
 - 1) Glue or staple a paper plate to a stick.
 - 2) Cut a black circle out of construction paper and place star stickers on it.
 - 3) Glue the black circle to a paper plate.



Day and Night

Put your hands over your eyes, like this. Demonstrate this motion. What do you see? That's right, NOTHING! Is it light or dark? Yes, it is dark. Open your Bible to Genesis. The Bible tells us that once it was very dark. There was no blue sky or bright sun.

Hold up Picture 1. Do you see any trees? Do you see any flowers? No! Everything was dark. Then the Bible says that God made the world. Say this next line slowly and softly, with emphasis. God said: "Let there be light" and "Let there be sky."

Hold up Picture 2. God put the sun in the sky in the daytime. Sometimes we can see the stars in the sky at night.

Hold up Picture 3. Let's put stars in the sky! Let each child place a star sticker on Picture 3. God made the twinkling stars, too.

God made the day and night, and God made the beautiful world we live in! Sing the first day of the "Creation Song" from the Unit 1 Song Sheet, while each child holds up one finger.



Day and Night

Creation 1

Lesson 1

Conclusion

Remember what the Bible says that God made?

Hold up Plate 1. God made the daytime, when we wake up. Hold up Plate 2. God made the nighttime, when we go to sleep. Hold up Plate 3. What else did God make? That's right, he made the clouds in the sky, and he made the sky. Hold up Plate 4. Look at this. God made the sun. Hold up Plate 5. God made the moon. What else did God make? Hold up Plate 6. God made the stars.

Let each child hold a plate and tell what God made. Let's thank God for making all of these things. Let each child thank God for the things he has made, using the Plate Pictures to prompt them. Sing the "Creation Song" again, if there is time.

Teacher Tips

- Speak slowly and in short sentences to twos and threes. They will understand more and will be more obedient when they have clear simple expectations.
- The lead teacher should keep the pictures and stick props to use in subsequent lessons.
- Practice telling the story with the pictures and props so that you are confident and animated and can give the children your full attention.

Day and Night Stick

This craft will help the child to identify day and night. Sun, moon and stars will also be identified, and the child will associate which are in the sky at night and which in the day. The child will also learn that God created all these things.

Materials

For each child:

- white, black and yellow construction paper
- craft stick
- 6 gold star stickers
- glue stick

For the teacher:

- scissors
- thin black marker

Reproducible Pages:

- Page C, 1 copy for the teacher
- Page D, 1 copy for the teacher

Preparation

1. Cut out the stencils from the copies of Reproducible Pages C and D.
2. For each child, trace the stencils and cut out the following shapes from the construction paper:
 - A. one white circle, 5"
 - B. one black circle, 5"
 - C. one yellow circle, 1³/₄"
 - D. one white crescent-shaped moon
3. Write the Bible Truth, "God Made Day and Night" on the craft stick. Leave 1/2" on the top of stick blank, the children will glue it to the circles.
4. Make a model to show the children.

Instructions

1. Show the children the completed craft. Ask them who made the day? The night?
2. Give each child a white circle, black circle, yellow circle and a white moon.
3. Have each child cover one side of the black circle with glue.

Day and Night

Creation 1

Lesson 1

4. Help the children glue the craft stick on the circle. Make sure the Bible Truth is still visible.
5. Help the children place the white circle on the back of the black circle, covering the top of craft stick, and press them together. See Figure A.
6. Have the children glue the yellow circle in the center of the white circle to represent the sun. See Figure B.
7. Help the children glue the white crescent-shaped moon on the black circle to represent night. See Figure C.
8. Have the children place the gold star stickers around the moon.
9. Write the children's names on their craft sticks.

NOTE: Give the models to the Core Bible Story teacher to use in the Unit 2 Lesson 3, Bible Story.

Conclusion

Let the children name the various things on their stick. Ask them, *What is in the sky at night? What is in the sky in the daytime? Ask, Who made the night?, Who made the day? Repeat the Bible Truth, God made day and night.*

Teacher Tips

- Felt can be used for the yellow sun or white moon.
- As the children are constructing the craft, talk about the items they are placing on the stick.
- Speak slowly and in short sentences to the twos and threes. They will understand more and will be more obedient when they have clear simple expectations.

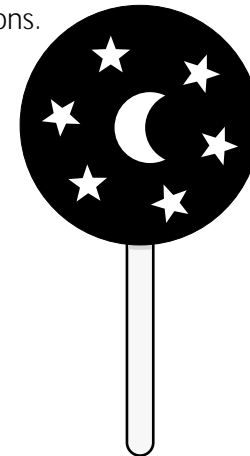

craft

Figure A

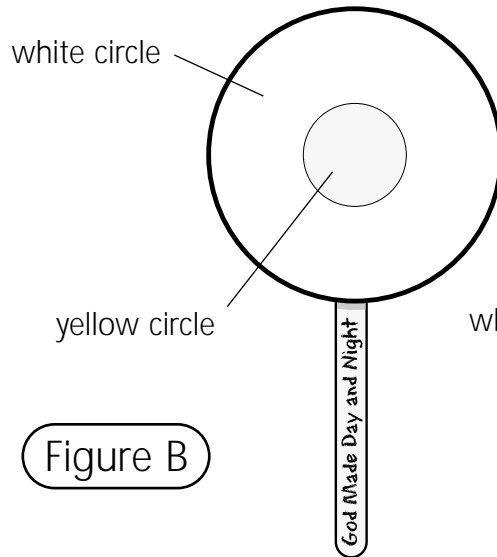
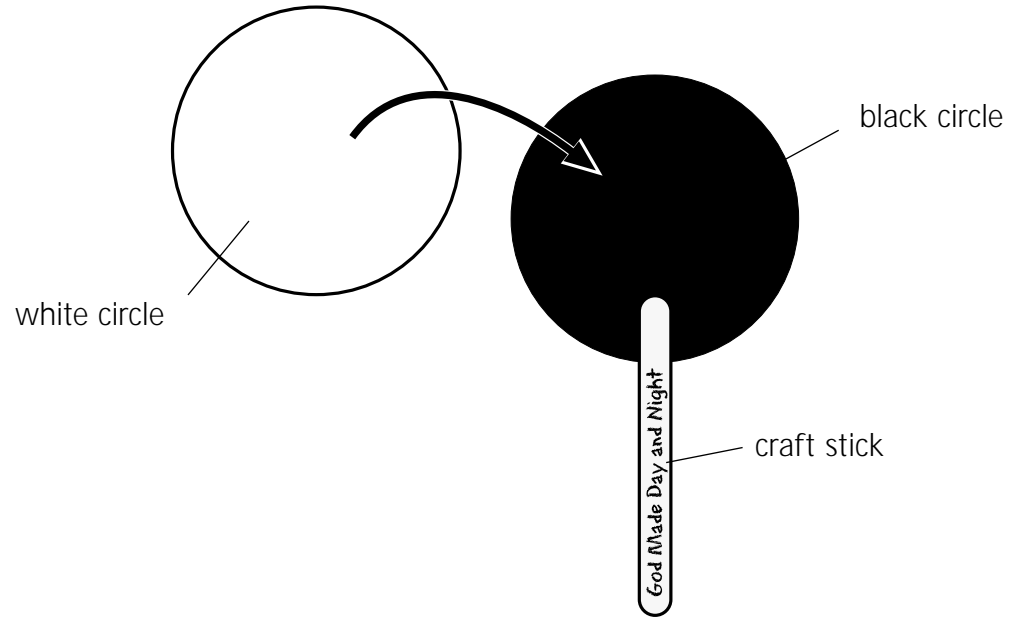

Figure B

front side

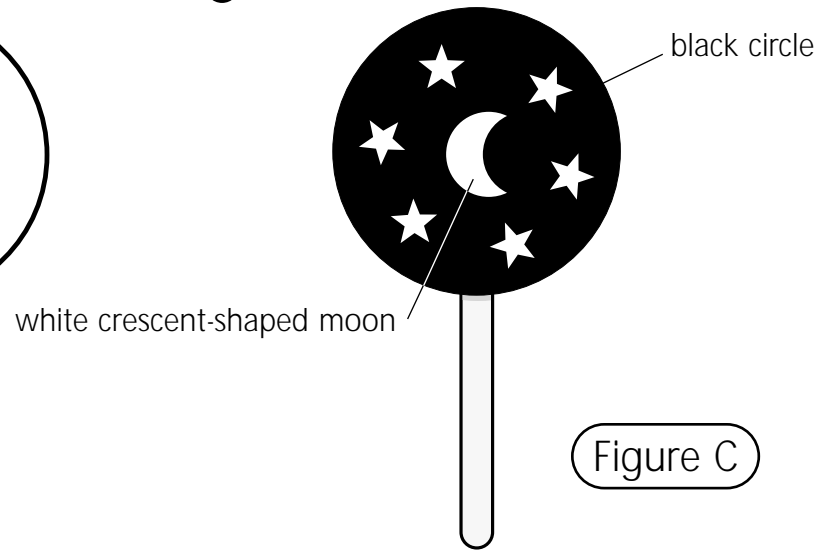

Figure C

back side





R
e
p
r
o
d
u
c
e
-
b
-
e



plate 1





R
e
p
r
e
s
e
n
t

Core/Bible Story 1 copy for the teacher
Supplement/Bible Story 1 copy for the teacher

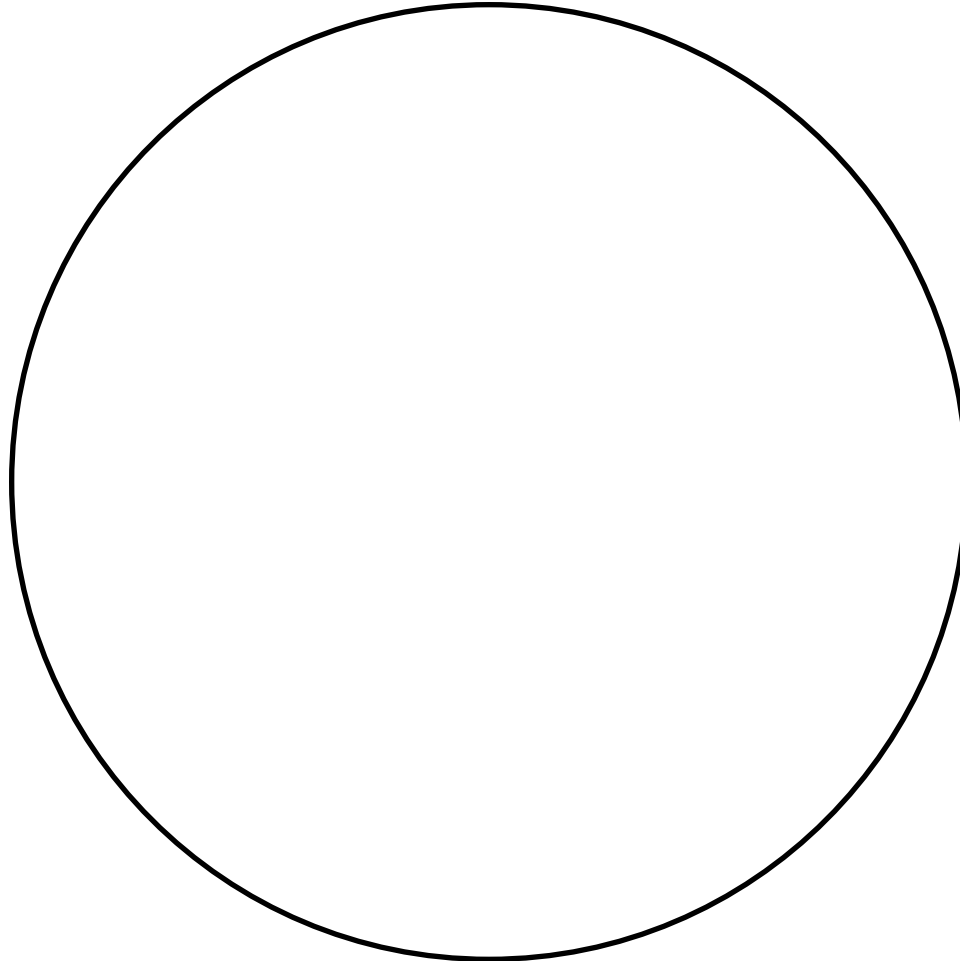

plate 2





R
e
p
r
o
d
u
c
i
b
l
e



circle stencil





R
e
p
r
o
d
u
c
i
b
l
e

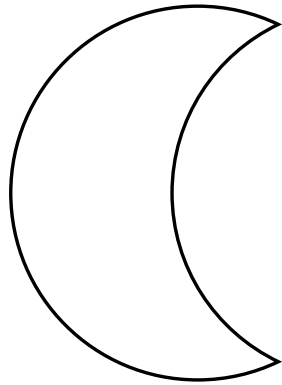

moon stencil

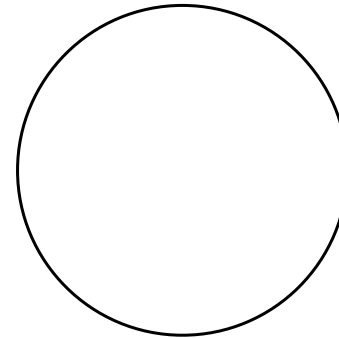

sun stencil

