

Fish

Lesson Objectives

- The children will recognize characteristics of fish.
- The children will understand that God made fish.
- The children will thank God for fish.

Bible Story Text

Genesis 1:20-23

Bible Truth

God made fish and birds.
(Genesis 1:21)

Lesson Plan

Greeting and Registration

Preclass Activity: Preclass Centers

Welcome and Singing

Centers:

Bible Story: God Made the Fish

Life Application: Creation Concentration

Craft: Aquarium

NOTE: Reopen preclass centers during check out.
Be sure to allow sufficient time for a snack.

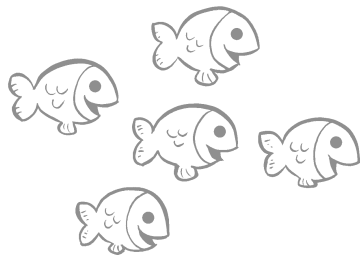
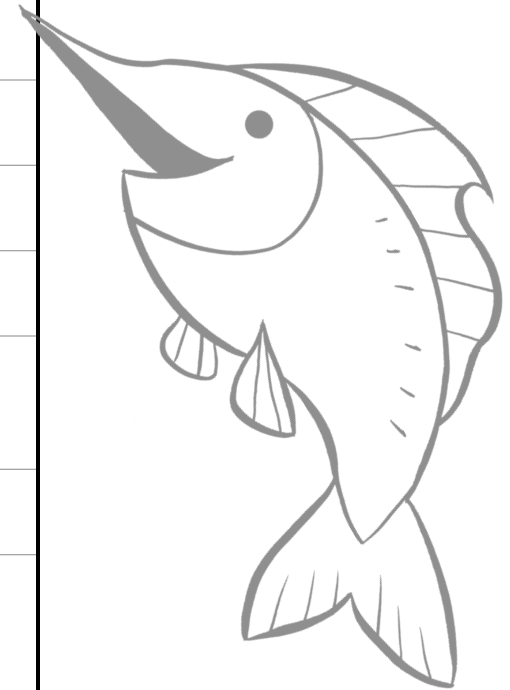

Fish

Preclass Centers

In the Preclass Centers children will use language, motor, and cognitive skills, learn to interact with peers and cooperate in small groups.

Select four centers to use this unit. Assign a teacher to set up and supervise each center with no more than six children.

Materials

IMPORTANT: Do not allow any small toys in the classroom. First check all toys for size. You can obtain a "safety cylinder" from a pediatrician. Any object that can fit into the cylinder is too small and could cause a child to choke.

- Housekeeping Center—2 washable dolls (of diverse ethnicity, i.e., black and white), play food, dishes and 2 small blankets
- Story Center—simple books with limited text (cardboard are the most sturdy and durable) and large pillows
- Block Center—set of large blocks, people, animal figures (plastic or wooden) and toy cars
- Puzzle Center—1 puzzle for each child (for twos—each puzzle piece itself should be a complete familiar object, for threes—most can complete a 20-piece puzzle). **NOTE:** A puzzle should have all of the pieces. If a puzzle piece is lost, the entire puzzle should be thrown out.

Instructions

Guide the play in each center reinforcing the unit theme. Refer to the following example for help in directing play and asking relevant questions.

In the Housekeeping Center, pretend to go fishing and then bring the fish home to cook for supper. Ask the children: *Where do fish come from? They live in the water. We can catch them and have them to eat.*

Teacher Tips

- You may want to try other centers, such as: transportation, large motor or manipulative.
- Wear comfortable clothes suitable for sitting on the floor.

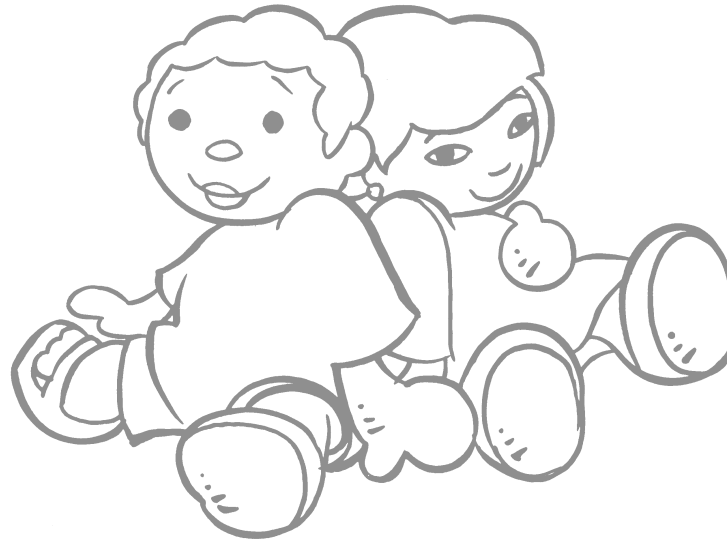

Fish

God Made the Fish

This lesson emphasizes how God created the fish.

Bible Story Text

Genesis 1:20-23

Materials

For the teacher:

- scissors
- 1 sheet of blue construction paper
- 1 sheet of laminate or clear contact paper (optional)
- tape (optional)
- bright colored markers
- glue stick
- 1 small bag of sand
- 1 round shallow tub for sand (size of a dishpan)
- 1 plastic tablecloth or sheet of plastic to put the sand tub on
- 1 small plastic bucket and shovel
- 6 sea shells (large enough to pass the safety cylinder test and with no sharp edges)

Reproducible Pages:

- Page A, 1 copy for the teacher

Preparation

1. Prepare the teaching picture as follows:
 - A. Color the copy of Reproducible Page A. Make sure that the fish are brightly colored.
 - B. Cut the sheet of blue construction paper to fit over the water portion of the picture. See Figure A. You may laminate the blue paper to make it stronger.
 - C. Cut out windows on three sides only so that they open to reveal the pictures of the fish underneath. See Figure B.
 - D. Glue the blue paper in place. Be careful not to glue the windows shut.
2. Prepare the beach scene as follows:
 - A. Lay the plastic tablecloth on the floor.
 - B. Fill the tub with sand and place it in the center of the tablecloth. The sand should be no more than two inches deep.
 - C. Put the bucket and shovel in the tub.

The Fish

Have you ever been to the beach? Isn't it fun to play in the sand? You can fill a bucket with sand using this shovel. Demonstrate this motion and let each child put one shovel of sand into the bucket. Have you ever picked up shells on the beach? Little fish and sea animals live in shells in the ocean. That is their home. Sometimes big waves come up on the beach and leave the shells behind.

Lay the shells down on the sand, one at a time. Let each child pick a shell up and look at it. Discuss shells as the children are doing this. Have the children lay the shells back on the sand when they have taken their turn. When all have had a turn, move the tub and shells out of sight.

Open the Bible. *The Bible says that God made all the living creatures in the ocean and seas—big ones and little ones. Hold up the teaching picture. What do we call animals that live in the water? That's right! Fish! Sometimes fish are our pets. Does anyone have a fish that lives in a bowl of water or in a fish tank? Let's find some fish in this water. Hold up the teaching picture. Open the windows to see the fish. Look at all the bright colors. What are the fish doing? Yes, they are swimming. God made the fish so they can swim in the water. What else can we find living in the water? Open up each window, name the fish and briefly describe them. Have you ever seen any of these? God made all of these fish able to swim in the water, breathe in the water, and eat things found in the water. God takes care of the fish. Are we fish? No! Can we breathe in the water? No! So, we do not go into the water without Mommy or Daddy.*

Conclusion

Who made the fish? That's right! God made the fish. Let's say it together, God made the fish. Let's thank God for all the fish that live in the water. Open each window again and let the children thank God for each fish that appears.

Sing the "Creation Song" from the Unit 3 Song Sheet. Hold up the number of fingers that correspond with the number of the day that you are singing about.



Fish

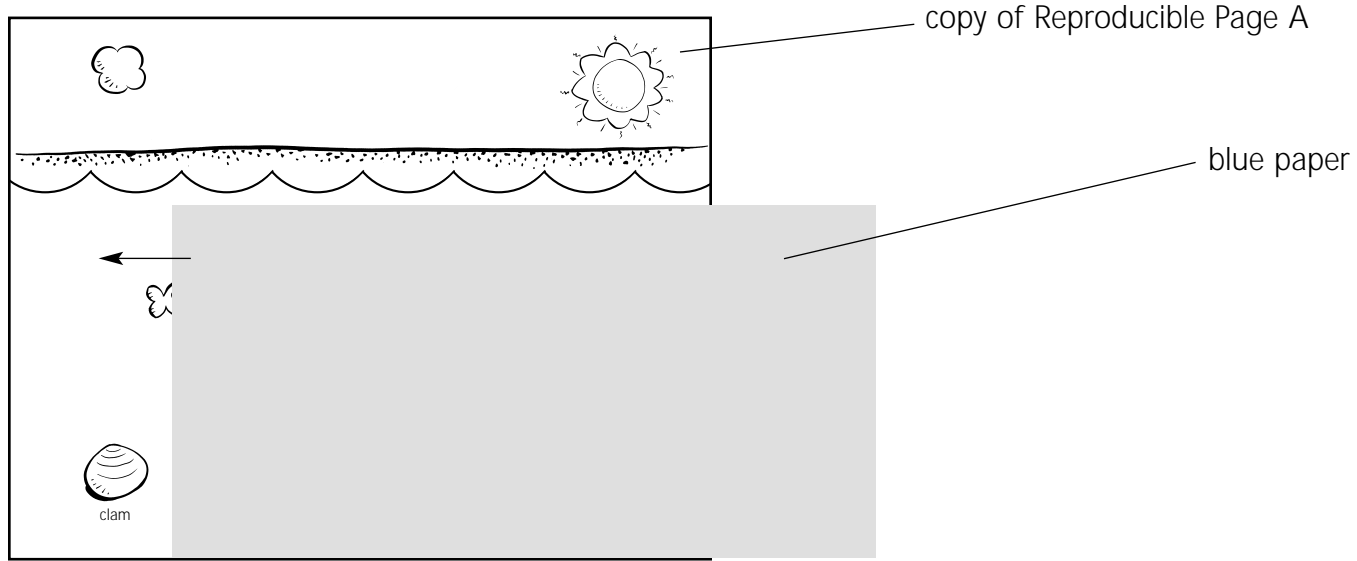

Figure A

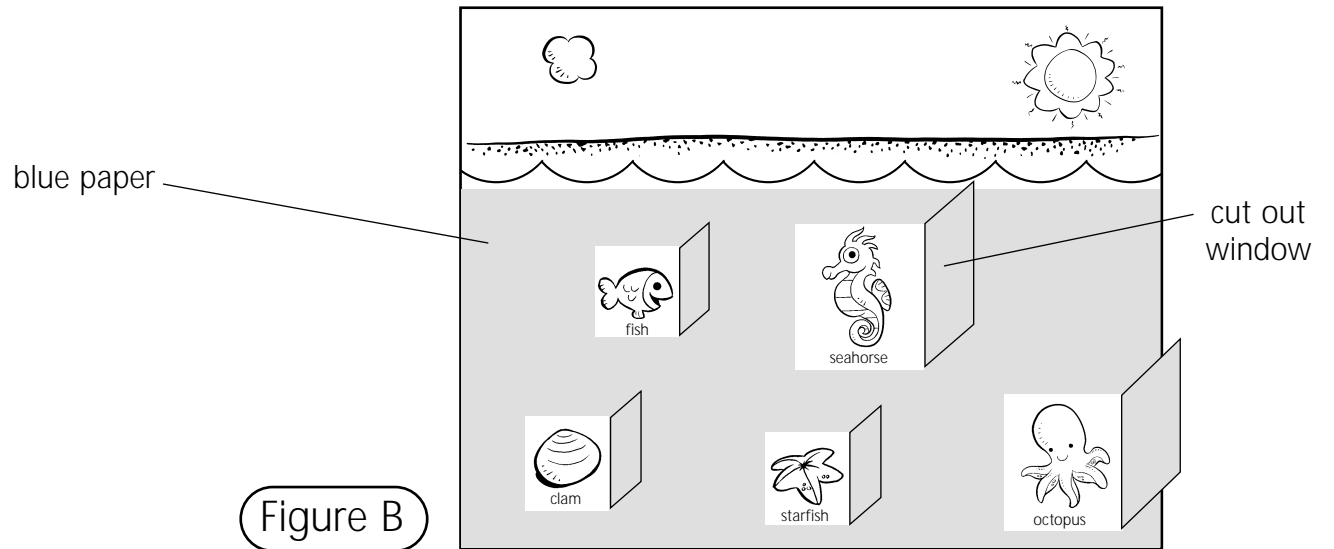

Figure B



Fish

Creation Concentration

Through playing this card game, the children will identify and state the following aspects of God's creation: day, night, sun, moon, stars, sky, white and dark clouds, apples, flowers, birds and fish.

Bible Truth

God made fish and birds. (Genesis 1:21)

Materials

For the teacher:

- Creation Concentration Cards from Unit 1 Lesson 3 and Unit 2 Lesson 3
- 4 unlined index cards, 3" x 5"
- scissors
- markers
- laminate or clear contact paper

Reproducible Pages:

- Page B, 2 copies for the teacher

Preparation

1. Prepare two sets of matching cards as follows:
 - A. From the copies of Reproducible Page B, cut out two of each image.
 - B. Color each set of images identically.
 - C. Glue each image onto a 3" x 5" card.
2. Familiarize yourself with the game.

Instructions

1. For the twos, play the game as detailed below:
 - A. Show the children one card of each pair and let them tell you what it is. This will help them to recognize the cards during the game.
 - B. Give each child a card and put the match to their card on the floor or table, face up. Each child's card will match a card laid out.
 - C. Ask each child, Can you find the match to your card? If they need help you might say, *I see you have a picture of the fish. Where is the other picture of the fish?* When they find the match, let them hold the pair.

- D. Say, *Who made the fish? God made the fish.* Encourage the children to repeat the answer with you.
 - E. The game is over when all cards are picked up. If there is time, play again.
2. For the threes, play the game as detailed below:
 - A. Show the children one card of each pair and let them tell you what it is. This will help them to recognize the cards during the game.
 - B. Put all the cards face down and mix them up.
 - C. Let each child take a turn flipping over two cards. If there is a match, the child holds the pair.
 - D. Say, *I see you picked up a fish. Who made the fish? God made the fish.* Encourage the older children to repeat the answer with you.
 - E. The game is over when all cards are picked up. If there is time, play again.

Bible Truth Activity

Show the children the bird card. Say, *Who made the birds? That's right! God did!* Show them the fish card. Say, *Who made the fish? That's right! God did! God made fish and birds. Let's all say it together. God made fish and birds.*

Conclusion

Sing days one through five of the "Creation Song" from the Unit 3 Song Sheet. Hold up one card from each pair as you sing and ask children after each verse: Who made that specific aspect of creation.

Let's thank God for creating fish and birds. Thank you, God, for creating fish and birds.

Who are you going to tell about Bible class today? What are you going to tell them?

Teacher Tips

- The cards will last a long time if you laminate or cover them with clear contact paper.
- These cards are useful if you need an activity to fill time or if you have a child who needs some extra attention or will not participate in a group activity.

God Made Fish and Birds.



Fish Aquarium

The child will make an aquarium as a reminder that God made fish.

Materials

For each child:

- 2 paper plates
- blue plastic wrap
- 6 fish-shaped crackers
- 1 small sprig of greenery, live or plastic
- glue stick

For the teacher:

- scissors
- stapler or tape

Preparation

1. Cut out the inside circles from half of the paper plates. See Figure A.
2. Glue or tape the plastic wrap over the front of each cut out plate. See Figure B.
3. Write "God Made Fish" on the back of each cut out plate.
4. Make a model of the completed craft following the instructions.

Instructions

1. Show the children your model of the craft.
2. Give the children each a whole paper plate and a sprig of greenery. Help the children glue their greenery to the centers of their whole plates. See Figure C.
3. Give the children each six fish-shaped crackers and help them use them as follows:
 - A. Help them glue three fish-shaped crackers to the centers of their paper plates.
 - B. Have them lay, but not glue three more fish-shaped crackers to the centers of their plates.
4. Have them place their cut out plates on top of the whole plates so the plastic is on the inside. See figure D.
5. Staple and tape the edges, as shown in Figure E. The finished craft will be shaped like a flying saucer.

Conclusion

Have the children shake their plates gently to see the fish "swim" in the water.

Reinforce the Bible truth. Say, *God made the fish. God made the fish to swim in the water. Thank you God for the fish.*

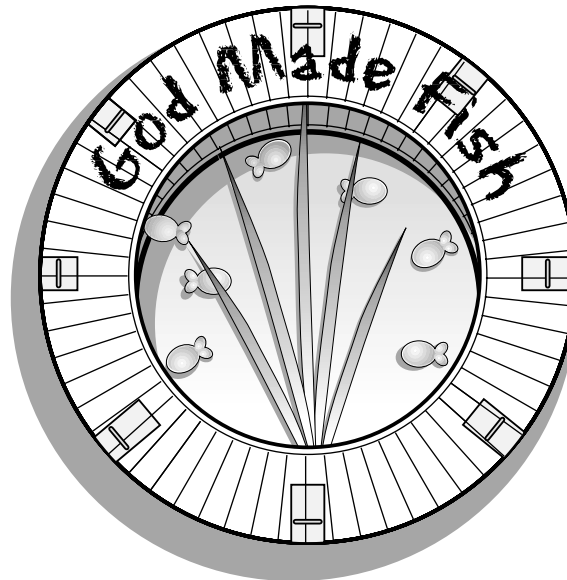

Fish

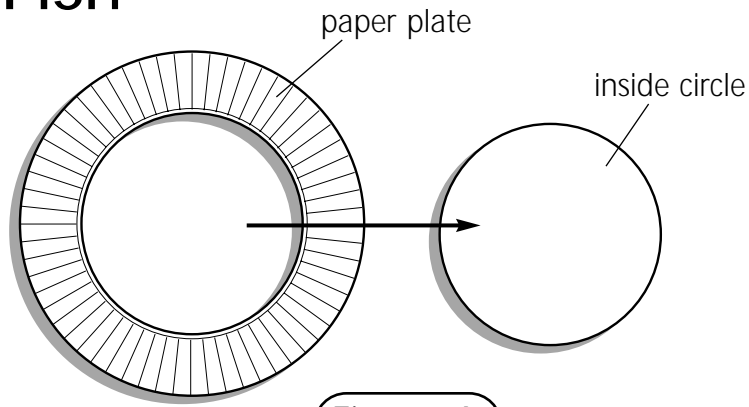

Figure A

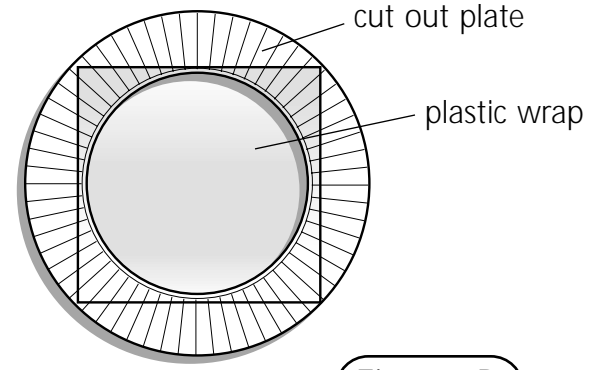

Figure B

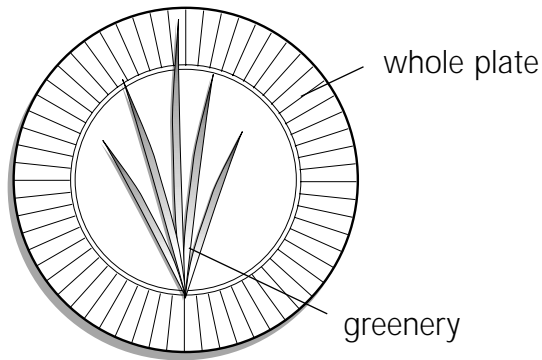

Figure C

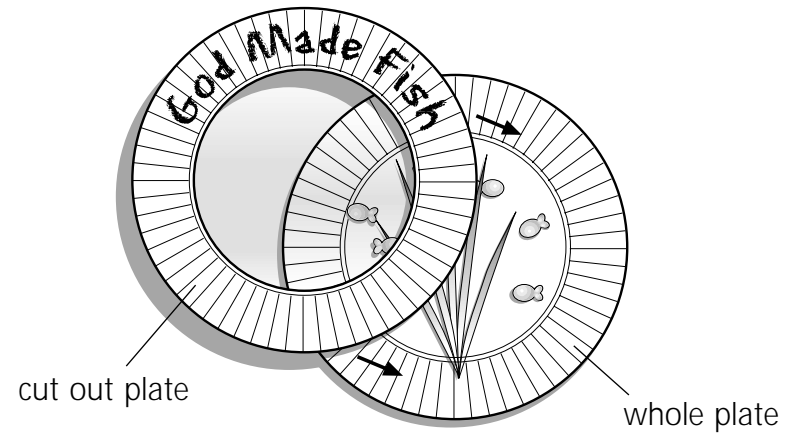

Figure D

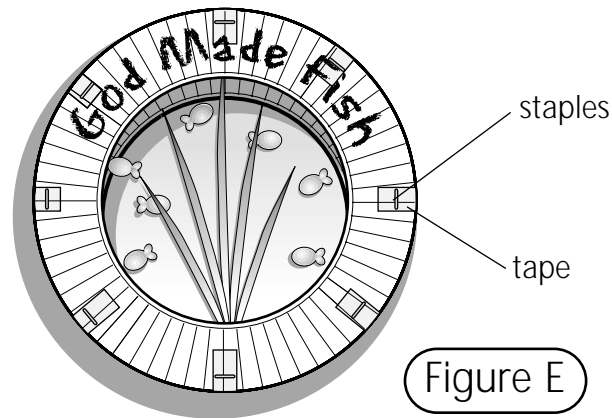

Figure E





Lesson Objectives

- The children will recognize characteristics of fish.
- The children will understand that God made fish.
- The children will thank God for fish.

Bible Story Text

Genesis 1:20-23

Bible Truth

God made fish and birds. (Genesis 1:21)

Lesson Plan

Greeting and Registration

Preclass Activity: Preclass Centers

Welcome and Singing

Centers:

Life Application: Let's Go Fishing

Bible Story: God Made the Fish

Craft: Paper Plate Fish

NOTE: Reopen preclass centers during check out.
Be sure to allow sufficient time for a snack.

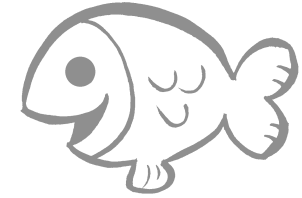

Preclass Centers

In the Preclass Centers children will use language, motor, and cognitive skills, learn to interact with peers and cooperate in small groups.

Select four centers to use this unit. Assign a teacher to set up and supervise each center with no more than six children.

Materials

IMPORTANT: Do not allow any small toys in the classroom. First check all toys for size. You can obtain a "safety cylinder" from a pediatrician. Any object that can fit into the cylinder is too small and could cause a child to choke.

- Housekeeping Center—2 washable dolls (of diverse ethnicity, i.e., black and white),

- play food, dishes and 2 small blankets
- Story Center—simple books with limited text (cardboard are the most sturdy and durable) and large pillows
- Block Center—set of large blocks, people, animal figures (plastic or wooden) and toy cars
- Puzzle Center—1 puzzle for each child (for twos—each puzzle piece itself should be a complete familiar object, for threes—most can complete a 20-piece puzzle). NOTE: A puzzle should have all the pieces. If a puzzle piece is lost, the entire puzzle should be thrown out.

Instructions

Guide the play in each center reinforcing

the unit theme. Refer to the following example for help in directing play and asking relevant questions.

In the Housekeeping Center, pretend to go fishing and then bring the fish home to cook for supper. Ask the children: *Where do fish come from? Yes, they live in the water. We can catch them and have them to eat.*

Teacher Tips

- You may want to try other centers, such as: transportation, large motor or manipulative.
- Wear comfortable clothes suitable for sitting on the floor.

Life

Application

Let's Go Fishing

The children will enjoy "fishing" and matching pairs in this activity. They will learn and sing that God made fish. This activity combines creativity, imagination, motor skills, visual perception, cognitive skills, as well as, learning a biblical truth.

Bible Truth

God made fish and birds. (Genesis 1:21)

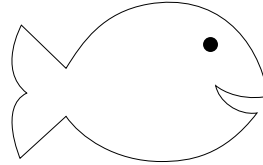

Materials

For the teacher:

- 1 stick, 2' long (or a wooden dowel or thin plastic pole)
- string
- hot glue gun
- magnet (use a refrigerator magnet temporarily)
- 6 pieces of different colored construction paper or poster board, wallpaper samples or felt
- laminate or clear contact paper
- 12 paper clips
- 1 bucket or small trash can

Reproducible pages:

- 1 copy of Reproducible Page C

Preparation

1. Make the stick into a fishing pole as follows:
 - A. Tie a string on the end of the stick and hot glue it in place.
 - B. At the other end of the string, tie or hot glue a magnet in place.
2. Make the fish as follows:
 - A. Cut out the fish stencil from the copy of Reproducible Page C.
 - B. Trace the fish onto the different colored construction paper and cut out six matching pairs. Note: You should have twelve fish—six pairs.
 - C. Laminate the fish or cover each with clear contact paper.
3. Put a paper clip into each fish's mouth.
4. Put all the fish into the bucket.
5. Familiarize yourself with the Life Application activity and the songs.

Go Fishing

1. Give the children each a turn to fish until they each catch one fish. Let them keep their fish. Once everyone has had a turn, let them each fish again until all the fish are caught.
2. As the children are fishing, ask them: *Who made the fish? God made the fish!*
4. After all of the fish have been caught, help the children match all the fish together by color. *For example say, Ashley has a red fish, who else has a red fish?*
5. Sing "I Wish I Were a Fish" and "I'm a Fish" from the Unit 3 Song Sheet.
6. When the fishing activities are over, put the pole out of reach so the children will not have access to it.

Bible Truth Activity

As you fish with the children, repeat the Bible Truth: "God made the fish." Ask the children, *Who made the fish? That's right! God did! Let's say it together. God made the fish.*

Conclusion

If time allows, place all of the fish in the bucket. Have each child draw out one fish by hand and say what color it is.

Let's thank God. Thank you, God, for the fish.

Who are you going to tell about Bible Class today? What are you going to tell them?

Teacher Tips

- **IMPORTANT:** Do not allow the children to put any part of the pole, string or magnet in their mouths. Be very careful to supervise the children with the fishing pole. Never leave a child alone with the pole.
- Some twos will not know their colors. They are still learning so encourage and help them. By the age of three children usually know their colors, but there are always exceptions.

God Made the Fish

This lesson emphasizes how God created the fish.

Bible Story Text

Genesis 1:20-23

Materials

For the teacher:

- scissors
- 1 sheet of blue construction paper
- 1 sheet of laminate or clear contact paper (optional)
- tape (optional)
- bright colored markers
- glue stick
- 1 small bag of sand
- 1 round shallow tub for sand (size of a dishpan)
- 1 plastic tablecloth or sheet of plastic to put the sand tub on
- 1 small plastic bucket and shovel
- 6 sea shells (large enough to pass the safety cylinder test and with no sharp edges)

Reproducible Pages:

- Page A, 1 copy for the teacher

Preparation

1. Prepare the teaching picture as follows:
 - A. Color the copy of Reproducible Page A. Make sure that the fish are brightly colored.
 - B. Cut the sheet of blue construction paper to fit over the water portion of the picture. See Figure A. You may laminate the blue paper to make it stronger.
 - C. Cut out windows on three sides only so that they open to reveal the pictures of the fish underneath. See Figure B.
 - D. Glue the blue paper in place. Be careful not to glue the windows shut.
2. Prepare the beach scene as follows:
 - A. Lay the plastic tablecloth on the floor.
 - B. Fill the tub with sand and place it in the center of the tablecloth. The sand should be no more than two inches deep.
 - C. Put the bucket and shovel in the tub.

The Fish

Have you ever been to the beach? Isn't it fun to play in the sand? You can fill a bucket with sand using this shovel. Demonstrate this motion and let each child put one shovel of sand into the bucket. Have you ever picked up shells on the beach? Little fish and sea animals live in shells in the ocean. That is their home. Sometimes big waves come up on the beach and leave the shells behind.

Lay the shells down on the sand, one at a time. Let each child pick a shell up and look at it. Discuss shells as the children are doing this. Have the children lay the shells back on the sand when they have taken their turn. When all have had a turn, move the tub and shells out of sight.

Open the Bible. *The Bible says that God made all the living creatures in the ocean and seas—big ones and little ones. Hold up the teaching picture. What do we call animals that live in the water? That's right! Fish! Sometimes fish are our pets. Does anyone have a fish that lives in a bowl of water or in a fish tank? Let's find some fish in this water. Hold up the teaching picture. Open the windows to see the fish. Look at all the bright colors. What are the fish doing? Yes, they are swimming. God made the fish so they can swim in the water. What else can we find living in the water? Open up each window, name the fish and briefly describe them. Have you ever seen any of these? God made all of these fish able to swim in the water, breathe in the water, and eat things found in the water. God takes care of the fish. Are we fish? No! Can we breathe in the water? No! So, we do not go into the water without Mommy or Daddy.*

Conclusion

Who made the fish? That's right! God made the fish. Let's say it together, God made the fish. Let's thank God for all the fish that live in the water. Open each window again and let the children thank God for each fish that appears.

Sing the "Creation Song" from the Unit 3 Song Sheet. Hold up the number of fingers that correspond with the number of the day that you are singing about.

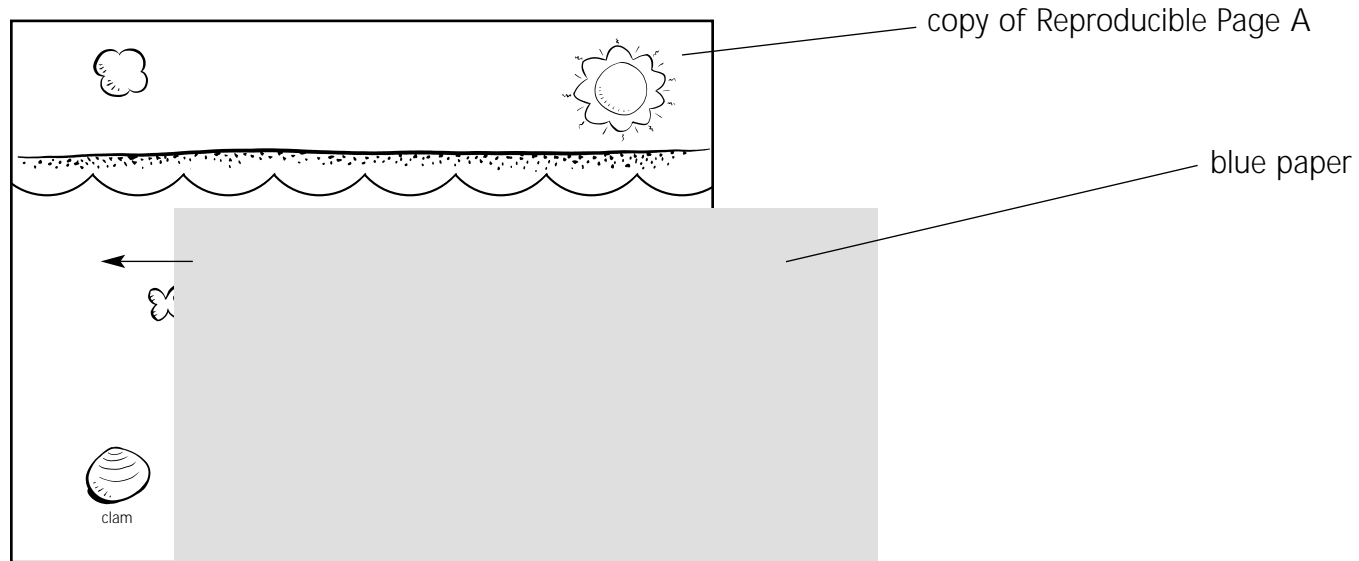

Figure A

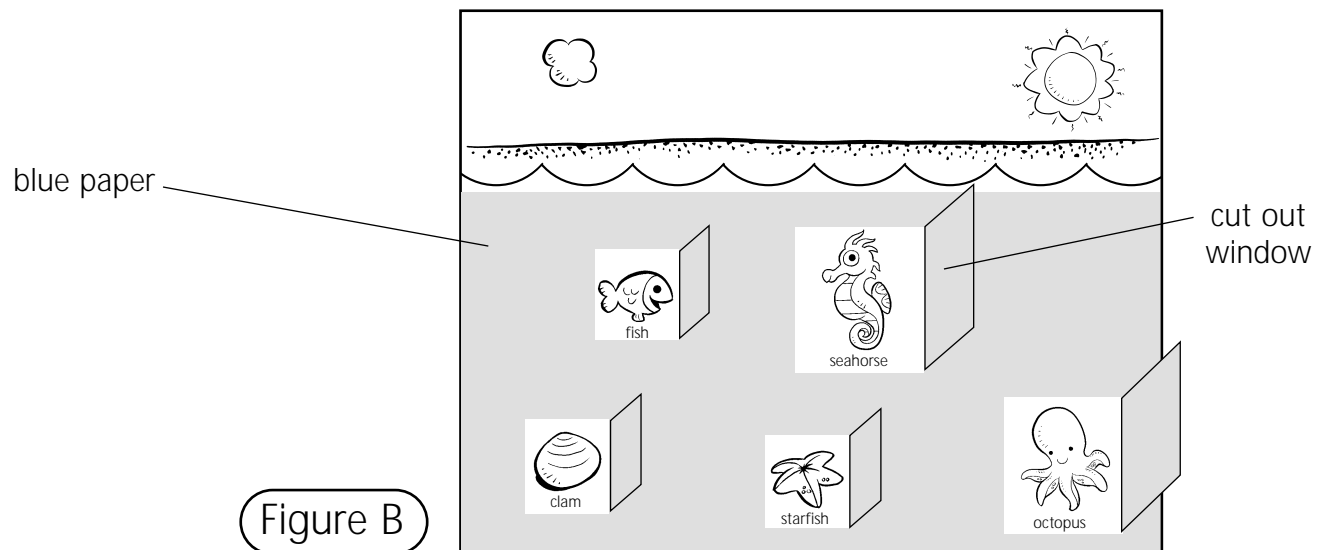

Figure B



Paper Plate Fish

The children will gain an appreciation of the beauty of God's creation as they make brightly colored fish.

Materials

For each child:

- 1 white paper plate
- glue sticks

For the teacher:

- several sheets of brightly colored tissue paper
- 1 sheet of black construction paper
- black marker

Preparation

1. Cut out a triangular wedge from each paper plate to represent a mouth.
2. Glue or staple the wedge to the opposite side of each plate to represent a tail. See Figure A.
3. Cut the tissue paper into squares or strips.
4. Cut out small circles from black construction paper about the size of a nickel. These will be fish eyes.
5. Write "God Made the Fish" on the back of each plate.
6. Make a model of the craft following the instructions.

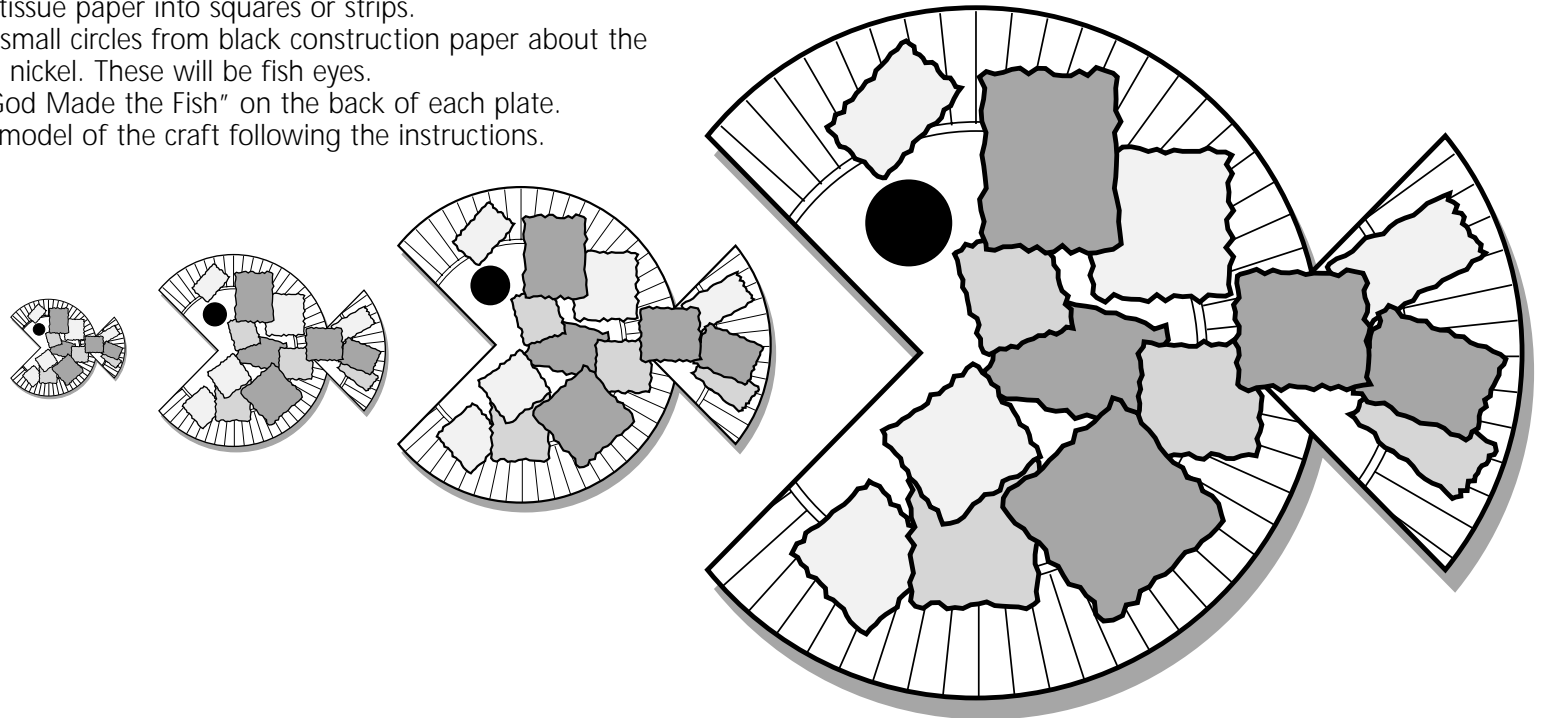

Instructions

1. Show the children the completed craft.
2. Place the tissue paper squares in the center of the table and let the children choose the colors they want. Have the children glue squares of tissue paper onto their fish.
3. Give the children each a paper eye to glue on their fish above the mouth.
4. Write the children's names on their crafts.

Conclusion

Repeat the Bible truth, *God made the fish*. If there is time, talk about how God made the fish many different colors.

Teacher Tips

Threes can make their own squares by tearing tissue that has been cut into strips. Twos will need the squares cut ahead of time.

Craft

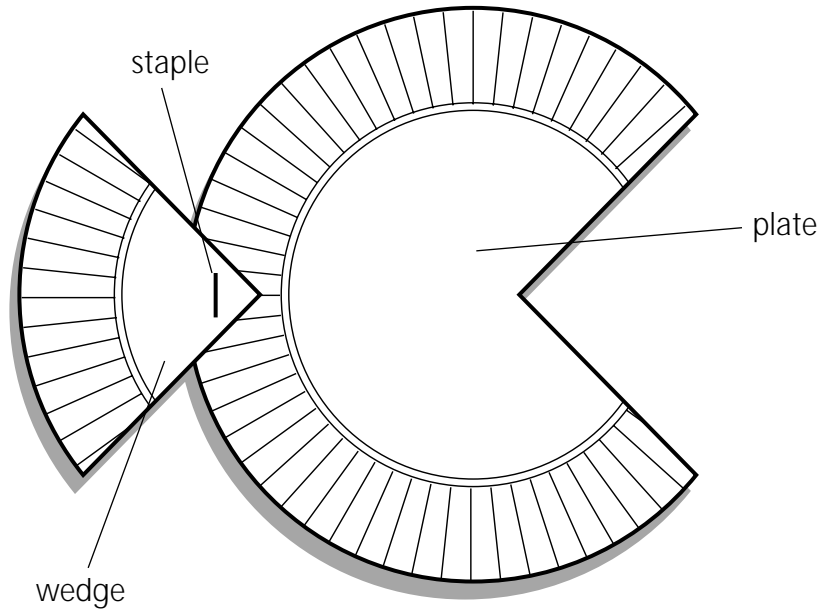
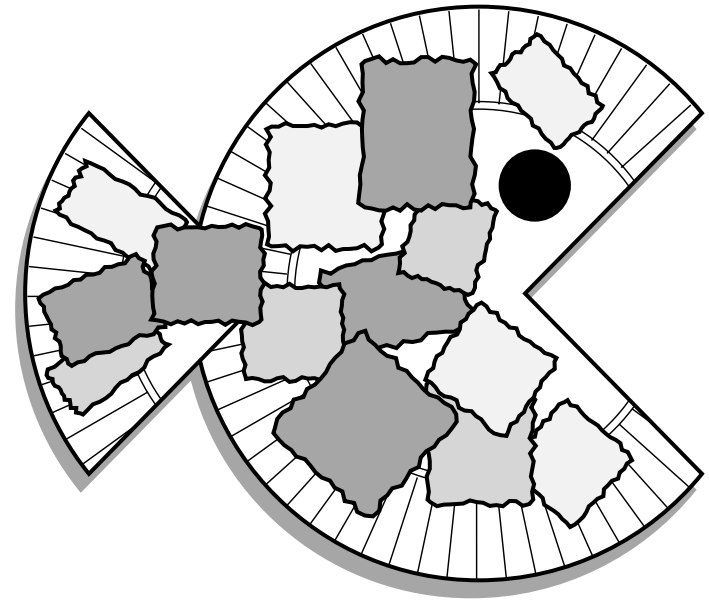

Figure A



Finished Craft





R
e
p
r
o
d
u
c
t
i
o
n

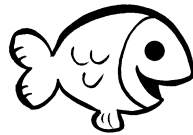
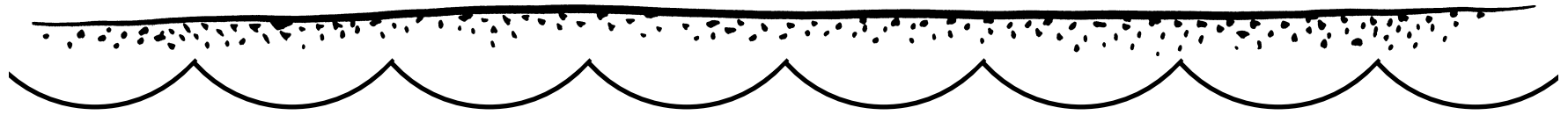
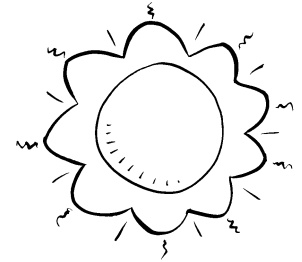

fish



seahorse



clam



starfish

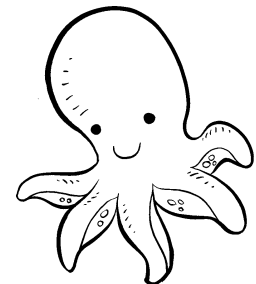

octopus





R
e
c
o
r
d
s
e
-
b
-
c
-
o
-
r
p
e
r
e

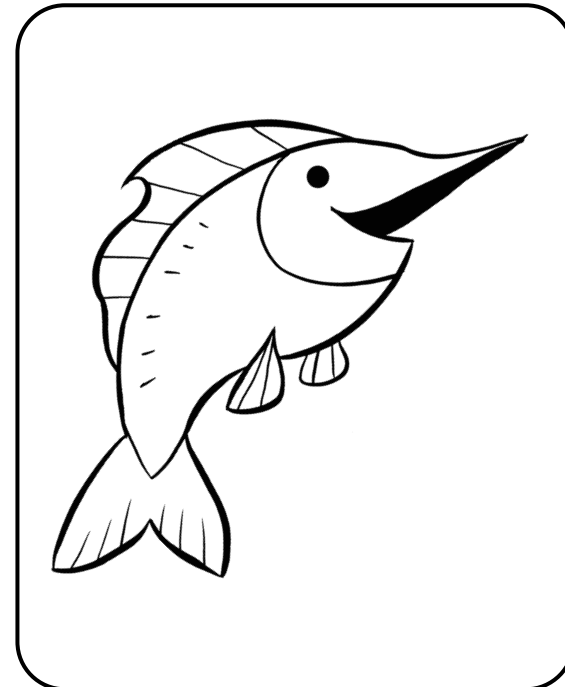
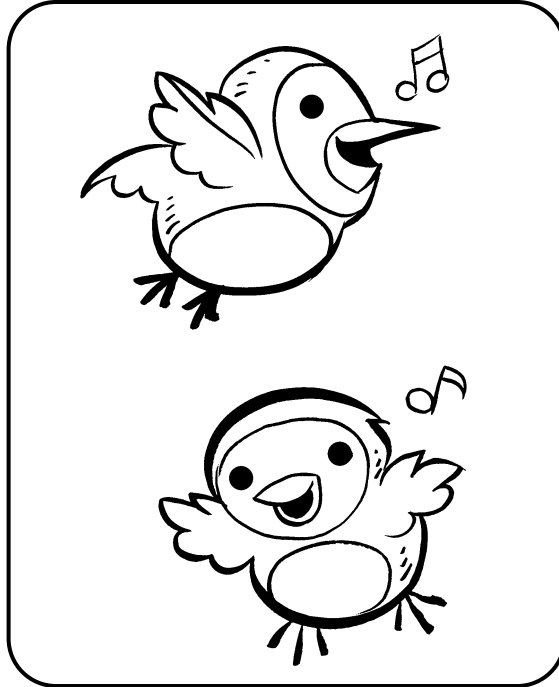

Creation Concentration Cards





R
e
p
r
o
d
u
c
i
b
l
e

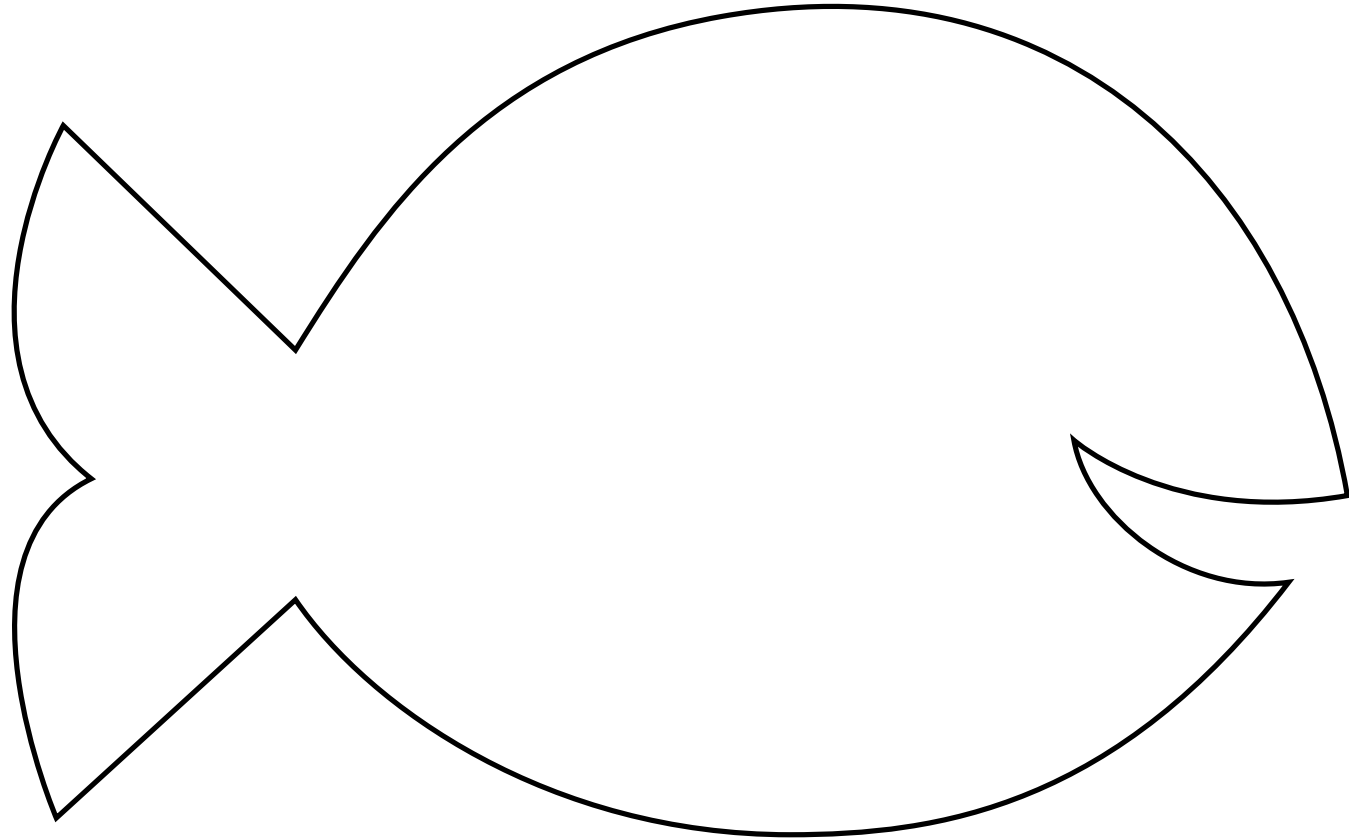

fish stencil

